

City of Portland, Maine - Building or Use Permit Application

389 Congress Street, 04101 Tel: (207) 874-8703, Fax: (207) 874-8716

Permit No: 04-1837	Issue Date: PERMIT ISSUED	CBL 306 B006001
-----------------------	-------------------------------------	--------------------

Location of Construction: 585 Riverside St	Owner Name: B & L Partners Llc	Owner Address: 277 Milton Rd	Phone: 207 728687
Business Name:	Contractor Name: Avery Services, Inc.	Contractor Address: 7 Thomas Drive Westbrook	Phone: 207 728687
Lessee/Buyer's Name	Phone:		

Past Use: commercial space <i>INDUSTRIAL/warehouse</i>	Proposed Use: commercial space w/new gas furnace and 1000 gallon tank <i>INDUSTRIAL/warehouse</i>	Permit Fee: \$165.00	Cost of Work: \$15,995.00	CEO District: 5
---	--	-------------------------	------------------------------	--------------------

FIRE DEPT: <input checked="" type="checkbox"/> <input type="checkbox"/> Denied	INSPECTION: Use Group: <i>I</i> Type: <i>HVAC</i>
--	--

Proposed Project Description: Install new gas furnace and 1000 gallon tank in commercial space <i>INDUSTRIAL/warehouse</i> <i>for existing Bldg on mezz,</i>	Signature: <i>[Signature]</i>	Signature: <i>JMB 1/13/05</i>
--	----------------------------------	----------------------------------

Permit Taken By: jharris	Date Applied For: 12/15/2004	Zoning Approval	
-----------------------------	---------------------------------	------------------------	--

<ol style="list-style-type: none"> This permit application does not preclude the Applicant(s) from meeting applicable State and Federal Rules. Building permits do not include plumbing, septic or electrical work. Building permits are void if work is not started within six (6) months of the date of issuance. False information may invalidate a building permit and stop all work.. 	Special Zone or Reviews <input type="checkbox"/> Shoreland <input type="checkbox"/> Wetland <input type="checkbox"/> Flood Zone <input type="checkbox"/> Subdivision <input type="checkbox"/> Site Plan Maj <input type="checkbox"/> Minor <input type="checkbox"/> MM <input type="checkbox"/> Date: <i>12/20/04</i>	Zoning Appeal <input type="checkbox"/> Variance <input type="checkbox"/> Miscellaneous <input type="checkbox"/> Conditional Use <input type="checkbox"/> Interpretation <input type="checkbox"/> Approved <input type="checkbox"/> Denied Date:	Historic Preservation <input checked="" type="checkbox"/> Not in District or Landmark <input type="checkbox"/> Does Not Require Review <input type="checkbox"/> Requires Review <input type="checkbox"/> Approved <input type="checkbox"/> Approved w/Conditions <input type="checkbox"/> Denied Date:
---	---	---	--

CERTIFICATION

I hereby certify that I am the owner of record of the named property, or that the proposed work is authorized by the owner of record and that I have been authorized by the owner to make this application as his authorized agent and I agree to conform to all applicable laws of this jurisdiction. In addition, if a permit for work described in the application is issued, I certify that the code official's authorized representative shall have the authority to enter all areas covered by such permit at any reasonable hour to enforce the provision of the code(s) applicable to such permit.

SIGNATURE OF APPLICANT	ADDRESS	DATE	PHONE
RESPONSIBLE PERSON IN CHARGE OF WORK, TITLE		DATE	PHONE

City of Portland, Maine - Building or Use Permit

389 Congress Street, 04101 Tel: (207) 874-8703, Fax: (207) 874-8716

Permit No: 04-1837	Date Applied For: 1211512004	CBL: 306 B006001
------------------------------	--	----------------------------

Location of Construction: 585 Riverside St	Owner Name: B & L Partners Llc	Owner Address: 277 Milton Rd	Phone:
Business Name:	Contractor Name: Avery Services, Inc.	Contractor Address: 7 Thomas Drive Westbrook	Phone (207) 772-8687
Tenant/Buyer's Name	Phone:	Permit Type: HVAC	

Proposed Use: Industrial space w/new gas furnace and 1000 gallon tank - in existing bldg on mezz.	Proposed Project Description: Install new gas furnace and 1000 gallon tank in industrial space
---	--

Dept: Zoning	Status: Approved	Reviewer: Marge Schmuckal	Approval Date: 12/20/2004	Ok to Issue: <input type="checkbox"/>
Note:				
Dept: Building	Status: Approved with Conditions	Reviewer: Jeanine Bourke	Approval Date: 0712812005	Ok to Issue: <input checked="" type="checkbox"/>
Note: 1113105 left vm w/Mike @ Avery to ask if they were installing a tank, that they need to provide a plot plan. Gave the fax to send in. 7128 never recieved plot plan, ok to issue				
1) Tank must be placed per setback quidelines of the NFPA 58				
Dept: Fire	Status: Approved with Conditions	Reviewer: Lt. MacDougal	Approval Date: 0111112005	Ok to Issue: <input type="checkbox"/>
Note:				
1) the liquid propane tank requires a seperate permit				



FILL IN AND SIGN WITH INK

306 B 006

APPLICATION FOR PERMIT HEATING OR POWER EQUIPMENT

To the INSPECTOR OF BUILDINGS, PORTLAND, ME.

The undersigned hereby applies for a permit to install the following heating, cooking or power equipment in accordance with the Laws of Maine, the Building Code of the City of Portland, and the following specifications:

Location / CBL _____ Use of Building OFFICE / WAREHOUSE Date 12/15/04
 Name and address of owner of appliance BEL PARTNERS
585 Riverside St - Portland
 Installer's name and address AVERY SERVICES, INC 7 THOMAS DRIVE
WESTBROOK, ME 0409 Telephone 207-772-8687
 FAX 20-74-09

Location of appliance:
 Basement Floor MEZZANINE
 Attic Roof

Type of Fuel:
 Gas Oil Solid

Appliance Name: Carrier GAS (LP) Furnace
 U.L. Approved Yes No

Will appliance be installed in accordance with the manufacture's installation instructions? Yes No

IF NO Explain: _____

The Type of License of Installer:

Master Plumber # _____
 Solid Fuel # _____
 Oil # _____
 Gas # PNT1431
 Other _____

Type of Chimney:
 Masonry Lined NA
 Factory built _____
 Metal NA
 Factory Built U.L. Listing # _____
 Direct Vent
 Type _____

Type of Fuel Tank
 Oil
 Gas

Size of Tank 1000 GAL

Number of Tanks 1

Distance from Tank to Center of Flame _____ feet.

Cost of Work: \$ 15,995.00
Permit Fee: \$ _____

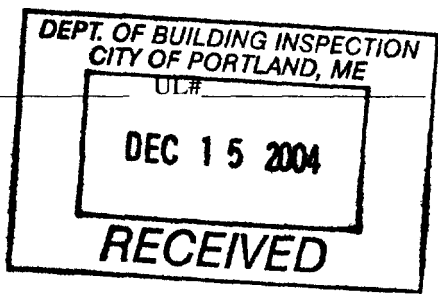

Approved
 Fire: _____
 Ele.: _____
 Bldg.: _____

Signature of Installer _____

Approved with Conditions
 See attached letter or requirement

Inspector's Signature _____ Date Approved _____



38TZA with Puron® Refrigerant

Carrier Corporation • Syracuse, N.Y. 13221
SUBJECT TO CHANGE WITHOUT NOTICE

38TZA WeatherMaker® AIR CONDITIONER with PURON® refrigerant

The model 38TZA air conditioner incorporates Puron® refrigerant to provide quiet, efficient operation with a standard cooling efficiency of 12SEER. Consult the PD for performance ratings. Additional features include WeatherArmor™ coil protection, High and Low Pressure switches for compressor protection and a standard 16 cubic inches filter drier for improved compressor reliability.

requirements. Refer to the combination ratings in the product data digest

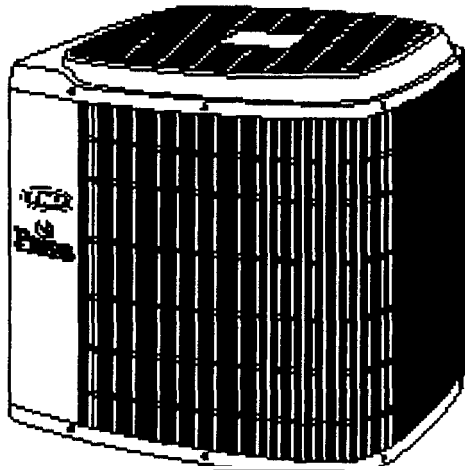

A01021



SYSTEM



this



ODS CATALOG ORDERING NO.	NOMINAL COOLING SIZE	VOLT-PHASE (60 HZ)	OPERATING VOLTAGE RANGE	PACKAGED DIMENSIONS (IN.) H X W X D*	APPROX SHIP. WT (LB)	PRICE
38TZA018---3	018	208/1230-1	187-253	31 X 31 X 36	205	1275
38TZA024---3	024	208/1230-1	187-253	31 X 31 X 36	210	1385
38TZA030---3	030	208/230-1	187-253	31 X 31 X 36	210	1621
38TZA036---3	036	208/230-1	187-253	31 X 31 X 36	213	1839
38TZA042---3	042	208/230-1	187-253	31 X 31 X 36	214	1963
38TZA048---3	048	208/1230-1	187-253	31 X 31 X 36	216	2239
38TZA060---3	060	208/230-1	187-253	43 X 31 X 36	258	2525



CE3A

Carrier Corporation • Syracuse N.Y. 13221
 SUBJECT TO CHANGE WITHOUT NOTICE

HORIZONTAL CASED DUCT COILS

Model CE3A Horizontal Cased Duct Coil is designed for use in any air distribution system having a horizontally positioned duct on the air-handling equipment. It is easily adaptable to most types of existing forced-air heating systems, or can be installed in an independent air-cooling system. The unit is direct expansion with a bypass AccuRater® and is designed for sweat refrigerant connections. Five year warranty on all parts.

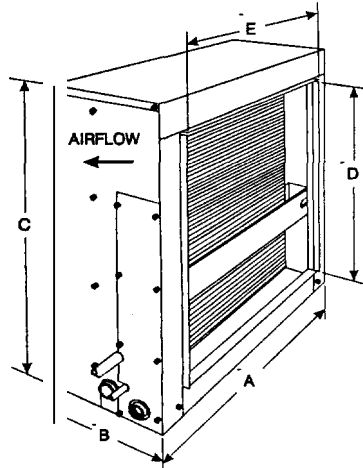

ODS CATALOG ORDERING NO.	FACTORY INSTALLED PISTON NO.	DIMENSIONS (IN.)					APPROX SHIP. WT (LB)	PRICE
		Depth A	Width B	Height C	D	E		
CE3AXA024000	59	24	9-3/4	25-1/8	21	16	46	221
CE3AXA030000	67	24	9-3/4	25-1/8	21	16	49	242
CE3AXA036000	70	28-3/4	9-3/4	25-1/8	21	23	55	279
CE3AXA042000	78	28-3/4	9-3/4	25-1/8	21	23	58	292
CE3AXA048000	84	25-5/16	11-5/8	26-1/2	20-7/8	23	65	344
CE3AXA060000	90	36-1/8	11-5/8	26-1/2	20-7/8	33-3/4	72	378

OPTIONAL EXTENDED WARRANTIES	NET PRICE
Labor Only — 2nd through 5th year Parts and Labor — 6 th through 10 th year (requires 2 nd through 5 th year labor) Parts Only — 6th year through 10th year Purchase within 5 years from date of installation	See Optional Warranty Price Section



EZXCAB

EZ FLEX AIR FILTER with Cabinet

Carrier Corporation • Syracuse, N.Y. 13221
SUBJECT TO CHANGE WITHOUT NOTICE

EZ FLEX FILTRATION SYSTEM

The Model EZXCAB filtration system is designed for installation in the return-air duct of any forced-air heating/cooling system. It is designed for use in systems with airflow up to 2000 CFM. The Model EZXCAB is available in 2 sizes, 0016 and 0020. The model EZXCAB features an EZ Flex expandable filter. The EZ Flex filter is a non-woven radial pleating highly efficient synthetic filter media designed to clean the air of particles as small as 0.3 microns.

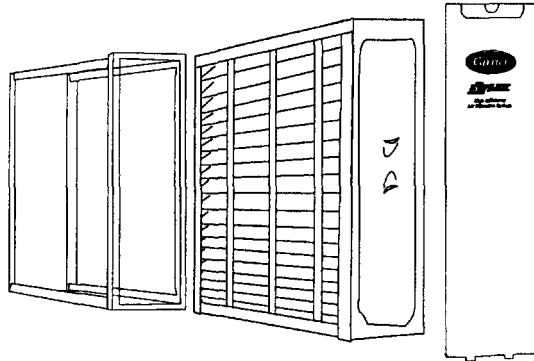

C02028

STANDARD FEATURES

- Powder-painted steel cabinet
- American Sterling gray color
- EZ Flex expandable pleated filter
- Low pressure drop
- MERV 10 cleaning efficiency
- Cabinet is convertible to the EAC-electronic air cleaner
- Cabinet supports up to 400 lb.
- Eligible for consumer financing
- Protects heating and cooling equipment

LIMITED WARRANTY

- 10-year (filter not included)

ODS CATALOG ORDERING NO.	DESCRIPTION	APPROX SHIP. WT (LB)	PRICE
EZXCABCC0016	Efficient Mechanical Air Cleaner 600-1600 CFM	18	160
EZXCABCC0020	Efficient Mechanical Air Cleaner 600-2000 CFM	20	164

EXTENDED WARRANTIES	NET PRICE
Mechanical Air Cleaner warranty available at NO ADDITIONAL CHARGE when accompanied with an extended warranty registration for an eligible system • Purchase within 5 years from date of installation	See Optional Warranty Price Section

ACCESSORY	ODS CATALOG ORDERING NO.	DESCRIPTION	PRICE
EZ-Flex Replacement Filter (0016)	EXPXXFIL0016-1	Replacement EZ Flex filters	31
EZ-Flex Replacement Filter (0020)	EXPXXFIL0020-1	Replacement EZ Flex filters	31



58MVP

Carrier Corporation • Syracuse, N.Y. 13221
SUBJECT TO CHANGE WITHOUT NOTICE

WEATHERMAKER™ INFINITY 4-WAY MULTIPOISE VARIABLE-CAPACITY DIRECT-VENT CONDENSING GAS FURNACE

The 58MVP Variable-Capacity Condensing Gas Furnace features ComfortHeat™ Technology and IdealHumidity™ that controls a 2-stage gas valve, variable-speed blower motor, and variable-speed inducer motor, for maximum heating comfort, quiet operation, humidity control, and ultra-high annual fuel utilization efficiency (AFUE) of up to 96.6 percent. The unit is CSA (A.G.A. and C.G.A.) certified for installation on combustible flooring and in alcoves, basements, closets, attics, crawlspaces, garages, or utility rooms. The 58MVP can be installed in upflow, downflow, or horizontal applications, and can be used in conjunction with a Split-System product for cooling. The direct-vent, sealed-combustion system uses 100 percent outdoor air for combustion. A Carrier Thermostat™ Control, humidifier, and air cleaner can be used to form a complete controlled environment system. All units meet California air quality management district emissive requirements. All sizes are design certified in Canada.

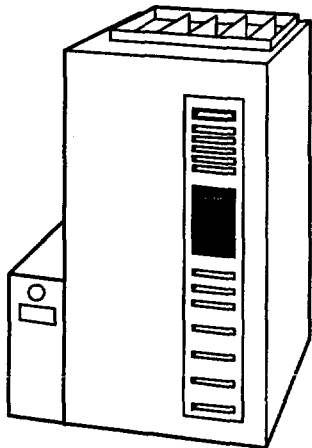

A00204

STANDARD FEATURES

- Factory-configured ready for upflow applications
- **4-way multipoise design** for upflow, downflow, or horizontal installation
- **ComfortHeat™ Technology Control**
- **Integral part of the IdealHumidity™ System**
- **SmartEvap™** can lower the humidity level in the home by nearly 10%
- Monoport inshot burners with **hot surface ignition**
- Propane convertible
- Variable-speed blower and inducer motors, 2-stage slow opening gas valve, and self-diagnostics
- Adjustable blower speed for cooling, continuous fan, and dehumidification
- Aluminized-steel primary heat exchanger
- **Serpentuff™ polypropylene-laminated condensing heat exchanger**
- **Fully insulated casing** including blower section
- Convenient electronic air cleaner and humidifier connections
- Media Filter Cabinet included
- **ComfortFan™** allows control of continuous fan speed from the thermostat
- Installation flexibility: sidewall or vertical vent
- Ultra quiet: no special noise or vibration isolation measures are required
- **Sealed combustion** uses outside air for combustion
- Up to 80 percent less electrical use than standard models
- Residential installations eligible for consumer financing through the Retail Credit Program

LIMITED WARRANTY

- Limited lifetime warranty on heat exchangers
- 5-year parts warranty on all other components



As an ENERGY STAR® Partner, Carrier Corporation has determined that this product meets the ENERGY STAR® guidelines for energy efficiency.



REGISTERED QUALITY SYSTEM



ODS CATALOG ORDERING NO.*	RATED HEATING OUTPUT (BTUH)		HEATING		COOLING CFM @ 0.5 ESP**	MOTOR HP (VARIABLE SPEED)	MEDIA CABINET SUPPLIED (IN.)	APPROX SHIP. WT(LB)	PRICE
	Low	High	CFM±Low/High	ESP					
58MVP040-F-1-14	25,000	37,000	565 (650±) / 1780	0.10	1400	1/2	24	231	1779
58MVP060-F-1-14	36,000	56,000	515 (590±) / 1010	0.12	1400	1/2	16	189	1836
56MVP080-F-1-14	49,000	75,000	690 (7953) / 1345	0.15	1400	1/2	20	218	1958
58MVP080-F-1-20	49,000	75,000	690 (795±) / 1345	0.15	2000	1/2	20	221	2082
58MVP100-F-1-20	61,000	93,000	860 (990±) / 1425	0.20	2000	1	20	243	2182
58MVP120-F-1-20	73,000	112,000	1035 (1190±) / 1710	0.20	2000	3/4	24	270	2303

PROPOSAL

778

AVERY SERVICES, INC.
7 Thomas Drive
WESTBROOK, MAINE 04092
(207) 772-8687

FAX (207) 874-0933

TO: SAS Construction
70 Bishop Street
Portland ME 04103

PHONE 450-0004 - Fax 878-2652	DATE 10/12/04
JOB NAME / LOCATION	
JOB NUMBER MSD # 490297	JOB PHONE

We hereby submit specifications and estimates for:

Awry Services, Inc. is pleased to submit a quote to perform the following work:

For the office area & the conference room & display & sales area:

- Provide & install a Carrier 58 MVP gas fired furnace with variable speed blower (uses 80% electricity & is 12 times quieter than a standard unit).
- Provide & install a Carrier CF3A cased cooling coil, or approved equal.
- Provide & install refrigerant lines between the two components. Low voltage wire included.
- Provide & install PVC flue venting for furnace.
- Provide & install a Carrier 38TZA Puron condensing unit (12 SEER), installed on a polymer pad.
- Provide & install a Carrier Comfort Zone System wing one (1) master control & three (3) remote room sensors.
- Provide & install a galvanized ductwork system comprised of twelve (12) lay in supplies and two (2) egg crate return grilles. All ductwork will be wrapped with 2" insulation with a vapor barrier.
- Provide & install a Carrier mechanical air cleaner.
- Provide & install gas piping for gas furnace only.

Exclusions: Power wiring, soffitng, structural.

We Propose to furnish material and labor — complete in accordance with the above specifications, for the sum of Fifteen Thousand Nine Hundred Ninety Five and 00/100 Dollars dollars (\$ 15,995.00).

Payment to be made as follows:

25% upon acceptance - Progress billing/net ten (10) days - All balances due at completion.

If payment is not made as outlined above, a service charge of 2% per month on the overdue balance plus all reasonable costs of collection, including attorney's fees will be paid.

All material is guaranteed to be as specified. All work to be completed in a professional manner according to standard practices. Any alteration or deviation from above specifications involving extra costs will be executed only upon written orders, and will become an extra charge over and above the estimate. All agreements contingent upon strikes, accidents or delays beyond our control. Owner to carry fire, tornado, and other necessary insurance. Our workers are fully covered by Worker's Compensation insurance.

Authorized Signature: [Signature] **PRESIDENT**

Note: This proposal may be withdrawn by us if not accepted within 30 days.

Acceptance of Proposal The above prices, specifications and conditions are satisfactory and are hereby accepted. You are authorized to do the work as specified. Payment will be made as outlined above:

Signature: [Signature]

Signature: Steve Sanders Project Manager

Date of Acceptance: 11/29/04

To Reorder: