

GENERAL NOTES:

1. REFER TO SPECIFICATIONS TO THE ARCHITECT'S DRAWINGS FOR ALL MATERIALS, FINISHES, AND CONSTRUCTION METHODS.
2. VERIFY ALL DIMENSIONS AND CONDITIONS WITH THE ARCHITECT BEFORE CONSTRUCTION.
3. VERIFY ALL DIMENSIONS AND CONDITIONS WITH THE ARCHITECT BEFORE CONSTRUCTION.
4. VERIFY ALL DIMENSIONS AND CONDITIONS WITH THE ARCHITECT BEFORE CONSTRUCTION.
5. VERIFY ALL DIMENSIONS AND CONDITIONS WITH THE ARCHITECT BEFORE CONSTRUCTION.
6. VERIFY ALL DIMENSIONS AND CONDITIONS WITH THE ARCHITECT BEFORE CONSTRUCTION.
7. VERIFY ALL DIMENSIONS AND CONDITIONS WITH THE ARCHITECT BEFORE CONSTRUCTION.
8. VERIFY ALL DIMENSIONS AND CONDITIONS WITH THE ARCHITECT BEFORE CONSTRUCTION.
9. VERIFY ALL DIMENSIONS AND CONDITIONS WITH THE ARCHITECT BEFORE CONSTRUCTION.
10. VERIFY ALL DIMENSIONS AND CONDITIONS WITH THE ARCHITECT BEFORE CONSTRUCTION.
11. VERIFY ALL DIMENSIONS AND CONDITIONS WITH THE ARCHITECT BEFORE CONSTRUCTION.
12. VERIFY ALL DIMENSIONS AND CONDITIONS WITH THE ARCHITECT BEFORE CONSTRUCTION.
13. VERIFY ALL DIMENSIONS AND CONDITIONS WITH THE ARCHITECT BEFORE CONSTRUCTION.
14. VERIFY ALL DIMENSIONS AND CONDITIONS WITH THE ARCHITECT BEFORE CONSTRUCTION.

REVISIONS:

1. ALL DIMENSIONS SHALL BE IN FEET AND INCHES UNLESS OTHERWISE SPECIFIED.
2. ALL DIMENSIONS SHALL BE TO FACE UNLESS OTHERWISE SPECIFIED.
3. ALL DIMENSIONS SHALL BE TO CENTERLINE UNLESS OTHERWISE SPECIFIED.
4. ALL DIMENSIONS SHALL BE TO THE CENTERLINE OF THE DOOR UNLESS OTHERWISE SPECIFIED.
5. ALL DIMENSIONS SHALL BE TO THE CENTERLINE OF THE WINDOW UNLESS OTHERWISE SPECIFIED.
6. ALL DIMENSIONS SHALL BE TO THE CENTERLINE OF THE CLOSET UNLESS OTHERWISE SPECIFIED.
7. ALL DIMENSIONS SHALL BE TO THE CENTERLINE OF THE SINK UNLESS OTHERWISE SPECIFIED.
8. ALL DIMENSIONS SHALL BE TO THE CENTERLINE OF THE MIRROR UNLESS OTHERWISE SPECIFIED.
9. ALL DIMENSIONS SHALL BE TO THE CENTERLINE OF THE TOILET UNLESS OTHERWISE SPECIFIED.
10. ALL DIMENSIONS SHALL BE TO THE CENTERLINE OF THE SHOWER UNLESS OTHERWISE SPECIFIED.
11. ALL DIMENSIONS SHALL BE TO THE CENTERLINE OF THE BATHTUB UNLESS OTHERWISE SPECIFIED.
12. ALL DIMENSIONS SHALL BE TO THE CENTERLINE OF THE VANITY UNLESS OTHERWISE SPECIFIED.
13. ALL DIMENSIONS SHALL BE TO THE CENTERLINE OF THE CLOSET UNLESS OTHERWISE SPECIFIED.
14. ALL DIMENSIONS SHALL BE TO THE CENTERLINE OF THE SINK UNLESS OTHERWISE SPECIFIED.

FORESIDE ARCHITECTS
 LLC
 P.O. Box 66736 Phone: 207-781-3344
 Falmouth, Maine 04105 Fax: 207-781-4774
 Online @ foresidearchitects.com

Project Status: CONSTRUCTION DOCUMENTS
 Project Number: CPS 1810
 Project Title: CHRISTMAN POOL SERVICE BUILDING RENOVATIONS
 336 Warren Avenue
 Portland, Maine, 04103

Drawing Name: ACCESSIBILITY STANDARDS
 Scale: 1/4" = 1'-0"
 Date: 09/15/10

PRELIMINARY PLANS
 NOT FOR CONSTRUCTION
 SHEET
G.3

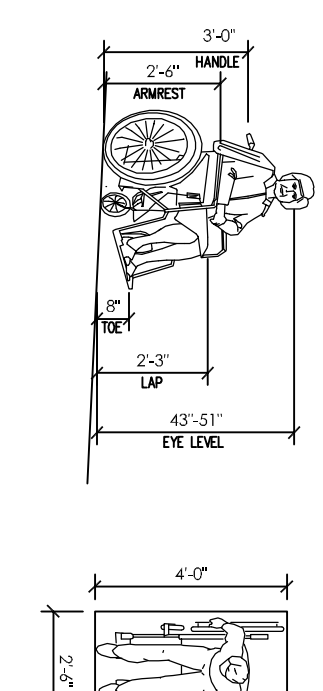

1 ADULT SIZE WHEELCHAIR DETAILS
 SCALE: 1/4" = 1'

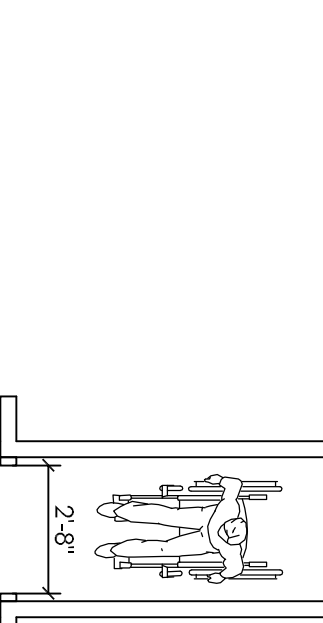

2 SINGLE WHEELCHAIR MIN. CLEAR WIDTH
 SCALE: 1/4" = 1'

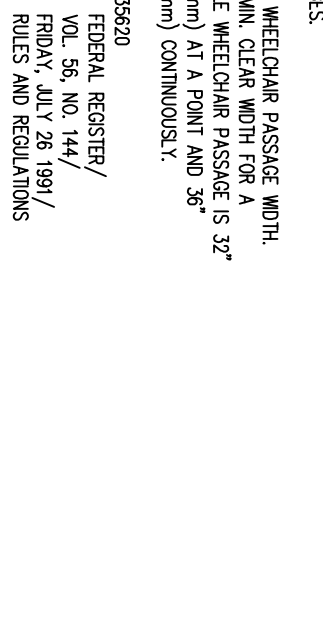

3 TWO WHEELCHAIR MIN. CLEAR WIDTH
 SCALE: 1/4" = 1'

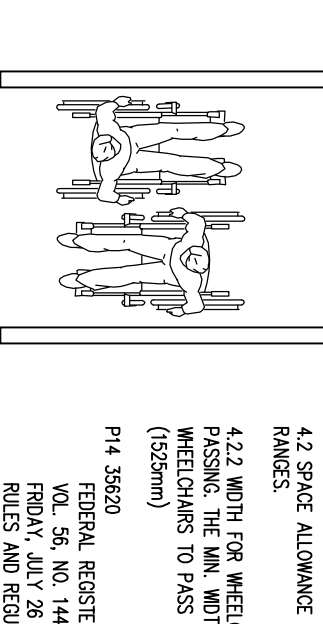

4 WHEELCHAIR TURNING SPACE
 SCALE: 1/4" = 1'



5 T-SHAPED SPACE FOR 180 DEG. TURNS
 SCALE: 1/4" = 1'

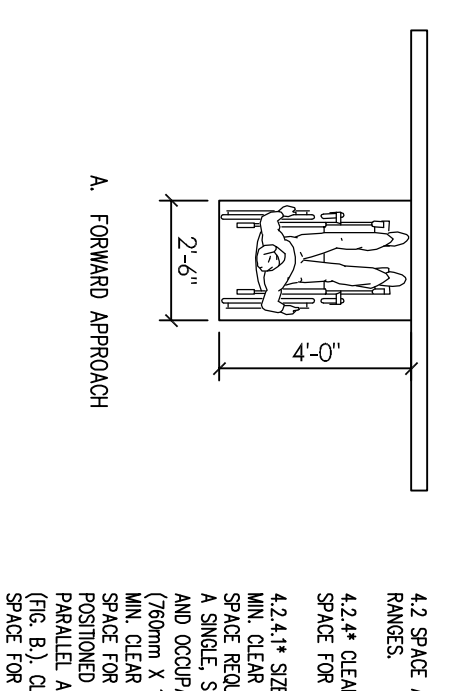

6 FORWARD AND PARALLEL APPROACHES
 SCALE: 1/4" = 1'

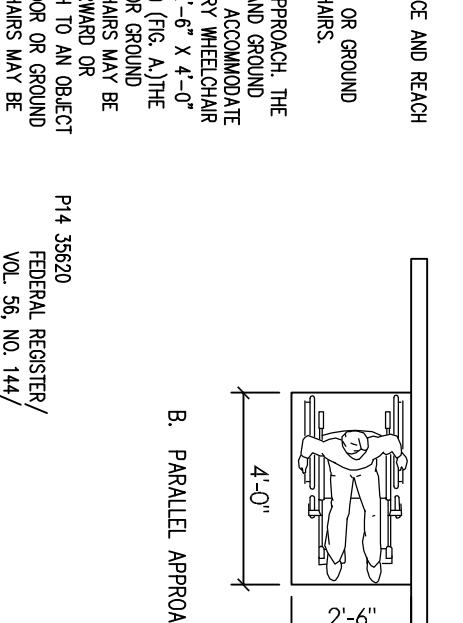

7 CLEARANCE FOR WALL FIXTURES
 SCALE: 1/4" = 1'



8 90 DEG. TURN
 SCALE: 1/4" = 1'

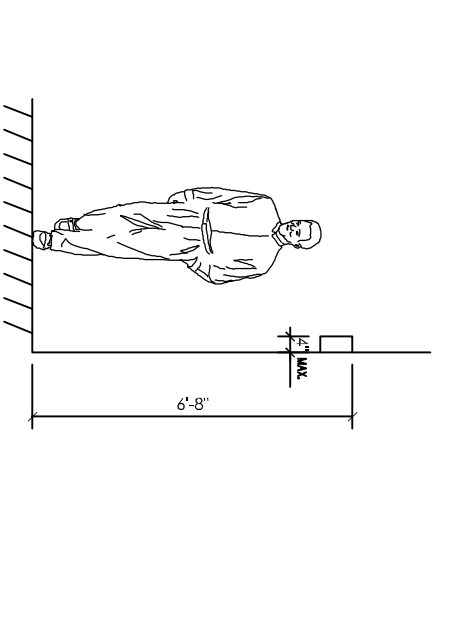

9 TURN AROUND AN OBSTRUCTION
 SCALE: 1/4" = 1'

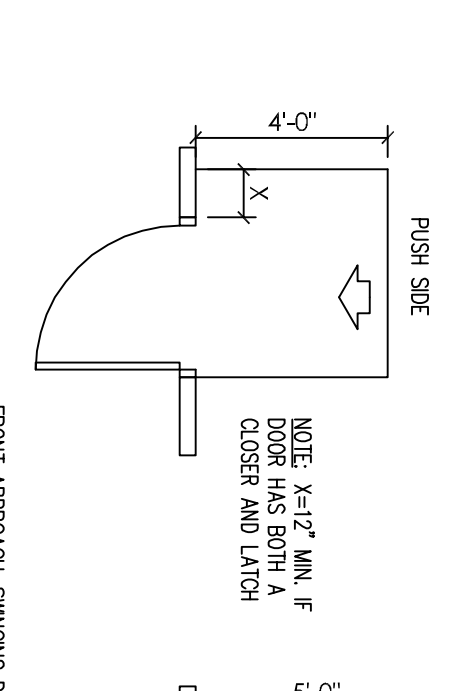

10 MANEUVERING CLEARANCES AT DOOR
 SCALE: 1/4" = 1'

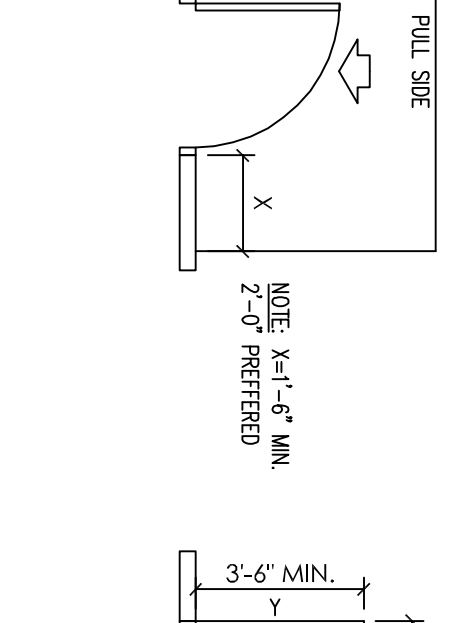

11 CLEAR FLOOR SPACE IN ALCOVE
 SCALE: 1/4" = 1'

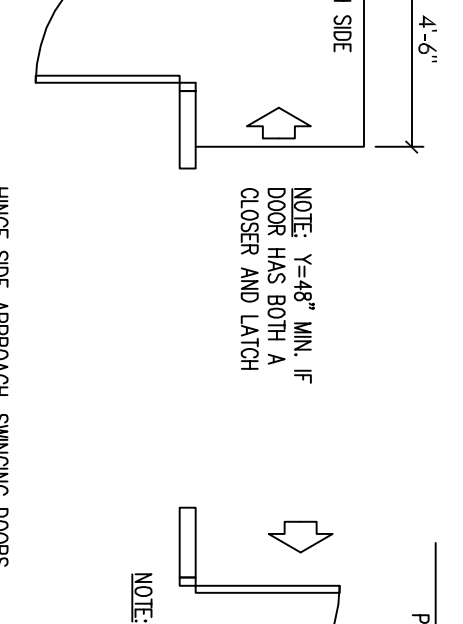

12 TWO HINGED DOORS IN SERIES
 SCALE: 1/4" = 1'

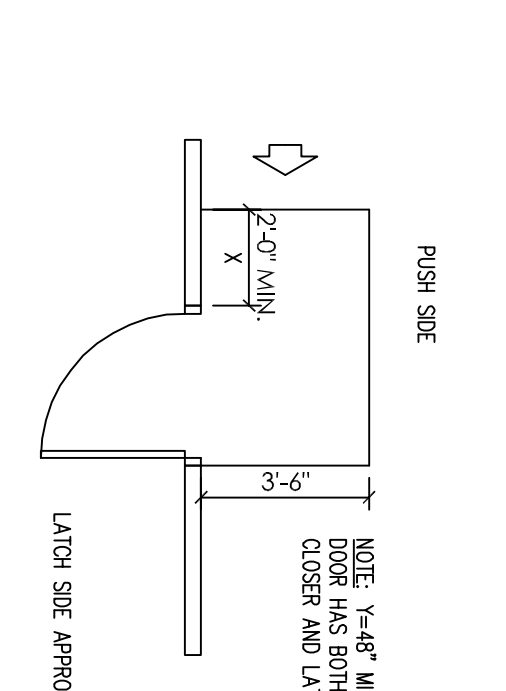

13 TOILET ROOMS FLOOR ELEVATIONS
 SCALE: 1/4" = 1'

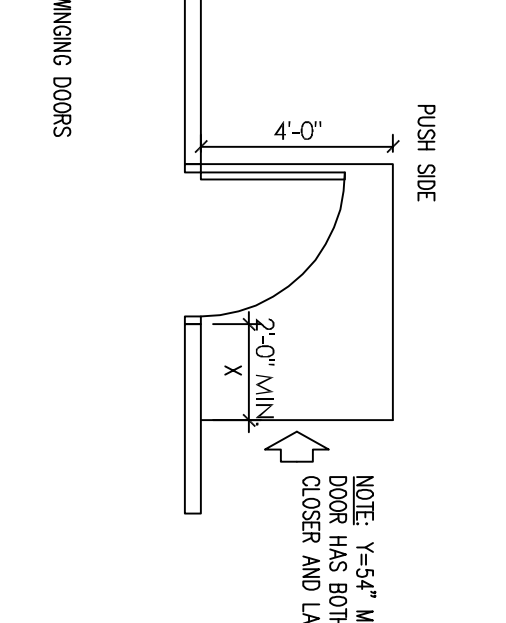

14 CLEARANCES FOR BATHROOMS AND MISC. ITEMS
 SCALE: 1/4" = 1'

13 TOILET ROOMS FLOOR ELEVATIONS
 SCALE: 1/4" = 1'

14 CLEARANCES FOR BATHROOMS AND MISC. ITEMS
 SCALE: 1/4" = 1'