

City of Portland, Maine - Building or Use Permit Application

389 Congress Street, 04101 Tel: (207) 874-8703, Fax: (207) 874-8716

Permit No: 10-1458	Issue Date:	CBL: 303 H011001
-----------------------	-------------	---------------------

Location of Construction: 336 Warren Ave	Owner Name: Doree Kevin P	Owner Address: 123 Gray Rd	Phone:
Business Name:	Contractor Name:	Contractor Address:	Phone:
Lessee/Buyer's Name	Phone:	Permit Type: HVAC	Zone: B-4

Past Use: Commercial	Proposed Use: Commercial / Install one (1) direct vent gas Carrier heating system.	Permit Fee: \$180.00	Cost of Work: \$15,800.00	CEO District: 5
Proposed Project Description: Install one (1) direct vent gas Carrier heating system.		FIRE DEPT: <input checked="" type="checkbox"/> Approved <input type="checkbox"/> Denied *See Conditions	INSPECTION: Use Group: B/S Type: HVAC IMC-2003	
		Signature: (KG)	Signature: JMB 12/6/10	
PEDESTRIAN ACTIVITIES DISTRICT (P.A.D.)				
Action: <input type="checkbox"/> Approved <input type="checkbox"/> Approved w/Conditions <input type="checkbox"/> Denied				
Signature: _____ Date: _____				

Permit Taken By: gg	Date Applied For: 11/22/2010	Zoning Approval		
------------------------	---------------------------------	------------------------	--	--

<p>1. This permit application does not preclude the Applicant(s) from meeting applicable State and Federal Rules.</p> <p>2. Building permits do not include plumbing, septic or electrical work.</p> <p>3. Building permits are void if work is not started within six (6) months of the date of issuance. False information may invalidate a building permit and stop all work..</p>	<p>Special Zone or Reviews</p> <input type="checkbox"/> Shoreland <input type="checkbox"/> Wetland <input type="checkbox"/> Flood Zone <input type="checkbox"/> Subdivision <input type="checkbox"/> Site Plan Maj <input type="checkbox"/> Minor <input type="checkbox"/> MM <input type="checkbox"/> Date: 11/23/10	<p>Zoning Appeal</p> <input type="checkbox"/> Variance <input type="checkbox"/> Miscellaneous <input type="checkbox"/> Conditional Use <input type="checkbox"/> Interpretation <input type="checkbox"/> Approved <input type="checkbox"/> Denied Date:	<p>Historic Preservation</p> <input checked="" type="checkbox"/> Not in District or Landmark <input type="checkbox"/> Does Not Require Review <input type="checkbox"/> Requires Review <input type="checkbox"/> Approved <input type="checkbox"/> Approved w/Conditions <input type="checkbox"/> Denied Date:
---	--	---	--

CERTIFICATION

I hereby certify that I am the owner of record of the named property, or that the proposed work is authorized by the owner of record and that I have been authorized by the owner to make this application as his authorized agent and I agree to conform to all applicable laws of this jurisdiction. In addition, if a permit for work described in the application is issued, I certify that the code official's authorized representative shall have the authority to enter all areas covered by such permit at any reasonable hour to enforce the provision of the code(s) applicable to such permit.

SIGNATURE OF APPLICANT ADDRESS DATE PHONE

RESPONSIBLE PERSON IN CHARGE OF WORK, TITLE DATE PHONE

City of Portland, Maine - Building or Use Permit

389 Congress Street, 04101 Tel: (207) 874-8703, Fax: (207) 874-8716

Permit No: 10-1458	Date Applied For: 11/22/2010	CBL: 303 H011001
-----------------------	---------------------------------	---------------------

Location of Construction: 336 Warren Ave	Owner Name: Doree Kevin P	Owner Address: 123 Gray Rd	Phone:
Business Name:	Contractor Name:	Contractor Address:	Phone:
Lessee/Buyer's Name	Phone:	Permit Type: HVAC	

Proposed Use: Commercial / Install one (1) direct vent gas Carrier heating system.	Proposed Project Description: Install one (1) direct vent gas Carrier heating system.
---	--

Dept: Zoning	Status: Approved	Reviewer: Marge Schmuckal	Approval Date: 11/23/2010	Ok to Issue: <input checked="" type="checkbox"/>
Note:				
Dept: Building	Status: Approved with Conditions	Reviewer: Jeanine Bourke	Approval Date: 12/06/2010	Ok to Issue: <input checked="" type="checkbox"/>
Note:				
1) The appliance and venting shall be installed in accordance with the UL listing, IMC 2003 and NFPA 211.				
2) The installation must comply with the State of Maine Gas Regulations.				
Dept: Fire	Status: Approved with Conditions	Reviewer: Capt Keith Gautreau	Approval Date: 12/02/2010	Ok to Issue: <input checked="" type="checkbox"/>
Note:				
1) Install shall comply with all manufacture's specifications.				
2) Install shall comply with NFPA 54. A compliance letter is required				



101458

FILL IN AND SIGN WITH INK

APPLICATION FOR PERMIT HEATING OR POWER EQUIPMENT



303 HOLL COM.

To the INSPECTOR OF BUILDINGS, PORTLAND, ME.

The undersigned hereby applies for a permit to install the following heating, cooking or power equipment in accordance with the Laws of Maine, the Building Code of the City of Portland, and the following specifications:

Location / CBL 336 WARREN AVE. Use of Building Pool Supplies Date 11/22/10
 Name and address of owner of appliance CHRISTMAN POOL INC. 336 WARREN AVE
PORTLAND ME. 04103
 Installer's name and address CHARLES SPIRZO DBA VINCENT HVAC. 111 GREENWOOD CV
PORTLAND ME, 04103 Telephone 878-7900

Location of appliance:
 Basement Floor
 Attic Roof

Type of Fuel:
 Gas Oil Solid

Appliance Name: CARRIER
 U.L. Approved Yes No

Will appliance be installed in accordance with the manufacture's installation instructions? Yes No

IF NO Explain: _____

RECEIVED

NOV 22 2010

Type of Chimney:
 Masonry Lined
 Factory built N/A
 Metal
 Factory Built U.L. Listing # N/A
 Direct Vent
 Type PVC UL# _____

Type of Fuel Tank
 Oil
 Gas N/A

Size of Tank 100# N/A
 Number of Tanks 2 N/A
 Distance from Tank to Center of Flame 80 N/A feet.
 Cost of Work: \$ 15,800
 Permit Fee: \$ 150.00

Approved

Fire: _____
 Ele.: _____
 Bldg.: _____

Approved with Conditions

See attached letter or requirement

Inspector's Signature

Date Approved

Signature of Installer Charles Vincent



**INFINITY™ ICS MODEL 58MVC
DELUXE 4-WAY MULTIPOISE VARIABLE-SPEED
MULTI-STAGE CONDENSING GAS FURNACE
Series 100, Input Rates: 60,000 thru 120,000 Btuh**

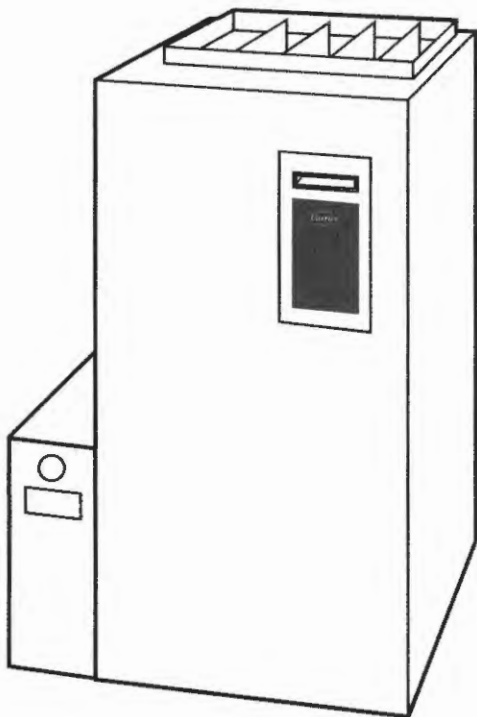

Product Data



A05069

 
IdealComfort. IdealHumidity

IdealComfort™ technology, the ultimate in heating comfort . . .

The Carrier Infinity™ ICS with IdealComfort™ technology achieves the optimum combination of comfort and efficiency.

The Infinity™ ICS achieves industry-leading ultra-high efficiency at up to 95 percent Annual Fuel Utilization Efficiency (AFUE). Efficient performance is enhanced through the variable-speed design. To optimize heating performance, IdealComfort™ automatically adjusts the heating level, maximizing the use of low heating levels that produce near silent furnace operation while meeting the exact heating needs. This unit is designed to keep the indoor temperature within less than 1 degree of the thermostat setpoint. Because it operates in low heat most of the time, the Infinity™ ICS uses up to 80% less power than single-capacity furnaces.

In addition to providing ultimate comfort, the Infinity™ ICS has a sealed combustion system. This system brings combustion air to the furnace and vents flue gases outside the furnace in a safe manner. Because it is sealed, operational noise is minimal. A sealed combustion system also means fewer cold drafts and less air infiltration.

The Infinity™ ICS is available in 5 heat/airflow combinations. The unit has a 4-way multipoise design and can be installed in upflow, downflow, or horizontal positions covering up to 20 different applications. The Infinity™ ICS can be vented as a Direct vent/2-pipe furnace or as an optional ventilated combustion air application.

The versatile 4-way multipoise design in conjunction with variable speed makes the Infinity™ ICS ideal for use with split system cooling, including 2-speed units. A Carrier Infinity™ air purifier, humidifier, comfort ventilator, and Infinity™ Zone control will provide year round comfort and efficiency.

Designed for durability, comfort, and reliability, the Infinity™ ICS is the ultimate in versatile, efficient comfort.

Carrier Infinity® System — When the Infinity™ ICS variable-speed gas furnace is matched with the Infinity™ Control (-B release is compatible) and an air conditioner or heat pump, the homeowner will experience the ultimate in IdealComfort™ and IdealHumidity™ through unparalleled control of temperature, humidity, indoor air quality, and zoning. The Carrier Infinity™ System also provides unprecedented ease of use through onscreen, text-based service reminders and equipment malfunction alerts.

For even greater comfort and convenience, match the Infinity™ ICS furnace with an Infinity air conditioner or heat pump. This will create a fully communicating system, requiring only 4 thermostat wires between system components. In some cases, troubleshooting can even be done from the outdoor unit without entering the home. Optional remote access through telephone or Internet is also available when combined with a remote connectivity kit.

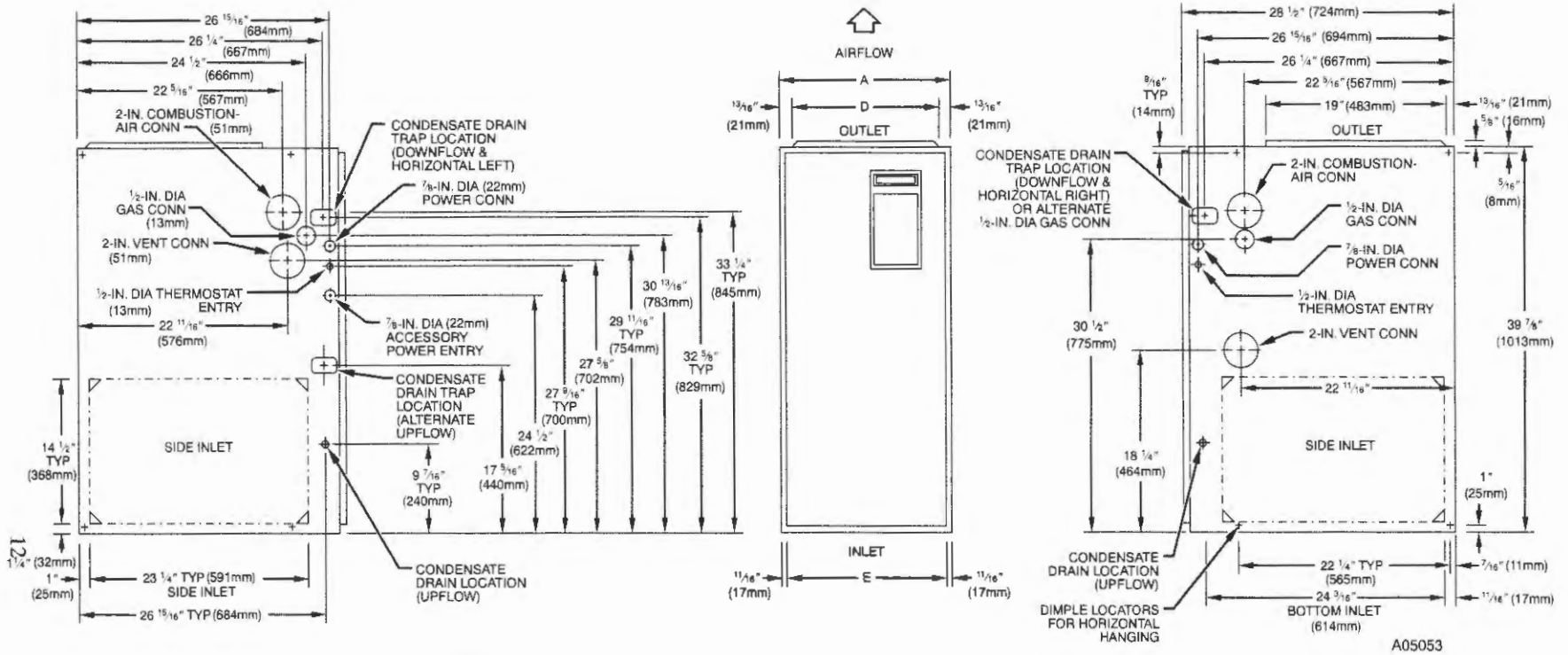

- NOTES:** 1. Minimum return-air openings at furnace, based on metal duct. If flex duct is used, see flex duct manufacturer's recommendation for equivalent diameters.
2. Minimum return-air opening at furnace:
- For 800 CFM 16-in. (406mm) round or 14 1/2 (368mm) x 12-in. (305mm) rectangle.
 - For 1200 CFM 20-in. (508mm) round or 14 1/2 (368mm) x 19 1/2-in. (495mm) rectangle.
 - For 1600 CFM 22-in. (559mm) round or 14 1/2 (368mm) x 23 1/4-in. (591mm) rectangle.
 - For airflow requirements above 1800 CFM, see Air Delivery table in Product Data literature for specific use of single side inlets. The use of both side inlets, a combination of 1 side and the bottom, or the bottom only will ensure adequate return air openings for airflow requirements above 1800 CFM at 0.5" W.C. ESP.

DIMENSIONS (IN / MM)			
UNIT SIZE	A	D	E
060-14	17-1/2 / 444.5	15-7/8 / 403.3	16 / 406.4
080-14	21 / 533.4	19-3/8 / 492.2	19-1/2 / 495.3
080-20	21 / 533.4	19-3/8 / 492.2	19-1/2 / 495.3
100-20	21 / 533.4	19-3/8 / 492.2	19-1/2 / 495.3
120-20	24-1/2 / 622.3	22-7/8 / 581.0	23 / 584.2

PHYSICAL DATA

DESCRIPTION	UNIT SIZE				
	060-14	080-14	080-20	100-20	120-20
Direct-Drive Motor Hp (ECM)	1/2	1/2	1	1	1
Motor Full Load Amps	7.7	7.7	12.8	12.8	12.8
RPM (Nominal)—Speeds	Variable 250 — 1300				
Blower Wheel Diameter X Width (in.)	10 X 7	11 X 10	11 X 10	11 X 10	11 X 10
Filter Size (in.) Nominal A (Washable)	(1) 16 X 25 X 1	(1) 20 X 25 X 1	(1) 20 X 25 X 1	(1) 20 X 25 X 1	(1) 24 X 25 X 1
Shipping Weight (lb)	170	182	204	203	234
Limit Control	SPST				
Heating Blower Control (Off Delay)	Selectable 90, 120, 150, or 180 SEC Intervals				
Burners (Monoport)	3	4	4	5	6
Gas Connection Size	1/2-in. NPT				
Gas Valve (Redundant) Manufacturer	White-Rodgers				
Minimum Inlet Pressure (in. wc)	4.5 (Natural Gas)				
Maximum Inlet Pressure (in. wc)	13.6 (Natural Gas)				
Ignition Device	Hot Surface -SiN				

58MVC

PERFORMANCE DATA

UNIT SIZE		060-14	080-14	080-20	100-20	120-20	
CERTIFIED TEMP RISE RANGE (° F)	Low	35 - 65	35 - 65	35 - 65	40 - 70	35 - 65	
	Medium	50 - 80	50 - 80	50 - 80	50 - 80	50 - 80	
	High	35 - 65	40 - 70	35 - 65	45 - 75	45 - 75	
CERTIFIED EXT STATIC PRESSURE (ESP)	Heating	0.12	0.15	0.15	0.20	0.20	
	Cooling	0.50	0.50	0.50	0.50	0.50	
AIRFLOW CFM‡	Heating Low	410 (470**)	540 (620**)	525 (605**)	660 (760**)	890 (1025**)	
	Heating Medium	545 (625**)	695 (800**)	685 (790**)	875 (1005**)	1095 (1260**)	
	Heating High	1070	1220	1470	1510	1900	
	Cooling (Max)	1400	1375	1975	1950	2060	
OUTPUT CAPACITY BTUH* (ICS)	Low	Upflow	22000	30000	30000	38000	46000
		Downflow	23000	30000	30000	38000	46000
		Horizontal	21000	30000	30000	38000	45000
	Medium	Upflow	37000	49000	49000	61000	73000
		Downflow	38000	49000	49000	61000	73000
		Horizontal	36000	49000	49000	61000	73000
	High	Upflow	56000	74000	74000	94000	112000
		Downflow	56000	74000	74000	94000	112000
		Horizontal	56000	74000	74000	93000	112000
AFUE%* Nonweatherized ICS	Upflow	95.0	95.0	95.0	95.0	95.0	
	Downflow	92.1	92.3	92.3	93.5	93.3	
	Horizontal	94.0	94.7	94.7	95.0	93.8	
INPUT BTUH†	Low	24000	32000	32000	40000	48000	
	Medium	39000	52000	52000	65000	78000	
	High	60000	80000	80000	100000	120000	

* Capacity in accordance with U.S. Government DOE test procedures.

† Gas input ratings are certified for elevations to 2000 ft. In U.S.A., for elevations above 2000 ft, reduce ratings 2% for each 1000 ft above sea level. In Canada, derate the unit 5% for elevations from 2000 to 4500 ft above sea level.

‡ Airflow shown is for bottom only return-air supply with factory-supplied 3/4-in. (76 mm) washable filter(s). For air delivery above 1800 CFM, see Air Delivery Table for other options.

** Low- and Medium-heat CFM when low/medium heat rise adjustment switch (SW1-3) on furnace control is used.

24APA5

Performance™ 15 Series Air Conditioner
with Puron® Refrigerant
1-1/2 to 5 Nominal Tons (Size 18-60)



Product Data



Performance
SERIES

Carrier's Air Conditioners with Puron® refrigerant provide a collection of features unmatched by any other family of equipment. The 24APA5 has been designed utilizing Carrier's Puron refrigerant. The environmentally sound refrigerant allows you to make a responsible decision in the protection of the earth's ozone layer.

As an Energy Star® Partner, Carrier Corporation has determined that this product meets the Energy Star® guidelines for energy efficiency. Refer to the combination ratings in the Product Data for system combinations that meet Energy Star® guidelines.

NOTE: Ratings contained in this document are subject to change at any time. Always refer to the AHRI directory (www.ahridirectory.org) for the most up-to-date ratings information.

INDUSTRY LEADING FEATURES / BENEFITS

Energy Efficiency

- 13.5 - 16.5 SEER/11.7-13.5 EER

New Aesthetic Design

- WeatherArmor Ultra™
 - Baked-on powder paint
 - Steel louver coil guard
 - Color matched cabinet screws

Extra Quiet Operation

- Silencer System II™ for sound as low as 66 dBA
 - Quiet mount split post compressor grommets
 - Exclusive Silencer top design
 - Forward-swept condenser fan blade
 - Compressor sound hood
 - Laminated compressor mounting plate

Reliability, Quality and Toughness

- Scroll compressor
- Field-installed 16 cu. in. filter drier
- 8-pole PSC ball-bearing condenser fan motor
- Back-seating service valves
- High-pressure switch
- Low-pressure switch
- Internal pressure relief valve
- Internal thermal overload

Controls and Diagnostics

- Infinity™ Control compatible
- Standard thermostat control with 3-wire or 2-wire 24v connection to outdoor unit. (2-wire capability starts with serial number 3006)
- Utility Interface Connection
- Up to 14 point diagnostic capability

Applications

- Longline - up to 250 ft. total equivalent length
- Low-ambient operation (down to 0°F) with complete Infinity™ System and crankcase heater
- Low-ambient operation (down to 0°F) with standard thermostat and additional accessories (see Accessory Usage Guideline in this document).

DIMENSIONS - ENGLISH

UNIT	SERIES	ELECTRICAL CHARACTERISTICS					A	B	C	D	E	F	G	K	L	M	N	P	R	OPERATING WEIGHT (lbs)	SHIPPING WEIGHT (lbs)	SHIPPING DIMENSIONS (L x W x H)
24APA518	0	X	0	0	0	29 1/4"	39 3/4"	8 1/16"	5/8"	5 5/8"	23 3/4"	10 1/16"	4 3/16"	1 1/8"	13"	18 1/2"	18 1/2"	33"	197	228	30 7/8" X 36 5/16" X 46 3/16"	
24APA524	0	X	0	0	0	29 1/4"	39 3/4"	8 1/16"	5/8"	5 5/8"	23 3/4"	10 1/16"	4 3/16"	1 1/8"	15 3/8"	15"	17 1/2"	33"	198	229	30 7/8" X 36 5/16" X 46 3/16"	
24APA530	0	X	0	0	0	35 1/2"	37 1/8"	6 5/16"	3/4"	6 13/16"	28 3/4"	11 5/8"	4"	1 1/8"	17 3/4"	19 1/4"	18"	40"	256	298	37 1/8" X 43 5/16" X 42 3/4"	
24APA536	0	X	0	0	0	35 1/2"	37 1/8"	6 5/16"	3/4"	6 13/16"	28 3/4"	11 5/8"	4"	1 1/8"	17 3/4"	16"	16 3/4"	40"	259	299	37 1/8" X 43 5/16" X 42 3/4"	
24APA542	0	X	0	0	0	35 1/2"	47 5/16"	6 1/4"	7/8"	6 13/16"	28 3/4"	11 5/8"	4 1/16"	1 1/8"	18 1/2"	18 3/4"	20"	40"	320	355	37 1/8" X 43 5/16" X 50 13/16"	
24APA548	0	X	0	0	0	35 1/2"	47 5/16"	6 1/4"	7/8"	6 13/16"	28 3/4"	11 5/8"	4 1/16"	1 1/8"	18 1/2"	18 3/4"	20"	40"	326	361	37 1/8" X 43 5/16" X 50 13/16"	
24APA560	0	X	0	0	0	35 1/2"	47 5/16"	6 1/4"	7/8"	6 13/16"	28 3/4"	11 5/8"	4 1/16"	1 1/8"	15 3/4"	21"	21 1/4"	40"	330	365	37 1/8" X 43 5/16" X 50 13/16"	

208-230-160	230-160	208/230-3-60	460-3-60
-------------	---------	--------------	----------

X = YES
O = NO

NOTES:

1. ALLOW 30" CLEARANCE TO SERVICE SIDE OF UNIT, 48" ABOVE UNIT, 6" ON ONE SIDE, 12" ON REMAINING SIDE, AND 24" BETWEEN UNITS FOR PROPER AIRFLOW.
2. MINIMUM OUTDOOR OPERATING AMBIENT IN COOLING MODE IS 55°F, MAX. 125°F.
3. SERIES DESIGNATION IS THE 13TH POSITION OF THE UNIT MODEL NUMBER.
4. CENTER OF GRAVITY 
5. ALL DIMENSIONS ARE IN "INCHES" UNLESS NOTED.

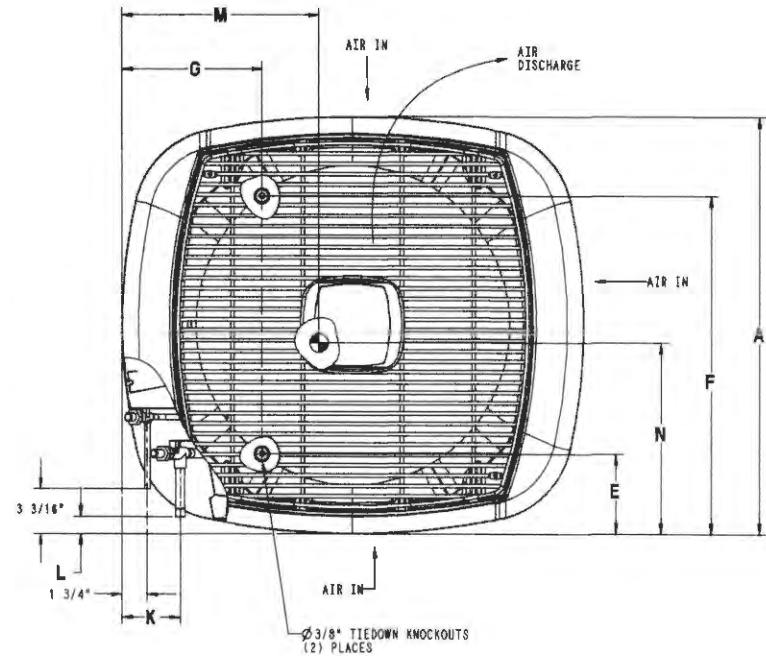
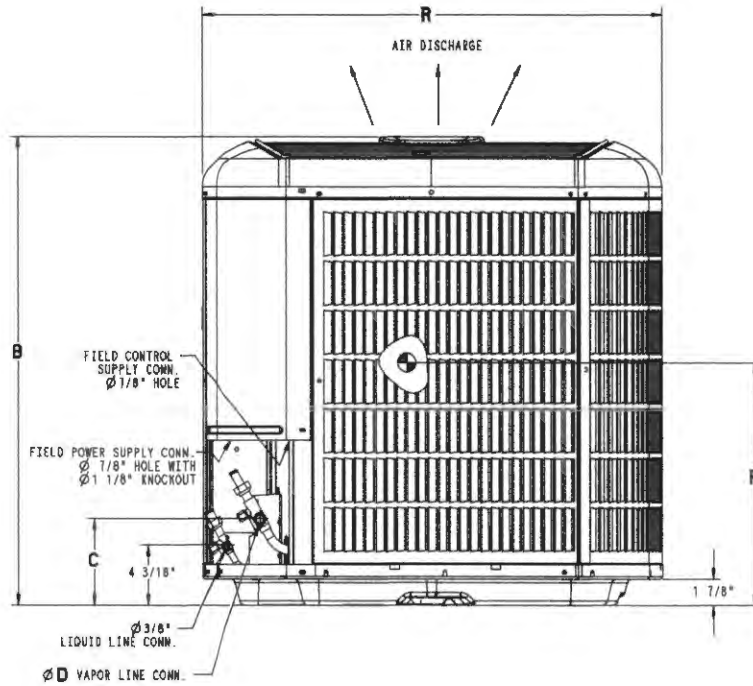

UNIT SIZE	MINIMUM MOUNTING PAD DIMENSIONS
18, 24	29 1/2" X 33"
30, 36, 42, 48, 60	36 1/2" X 40"

DIMENSIONS - SI

UNIT	SERIES	ELECTRICAL CHARACTERISTICS				A	B	C	D	E	F	G	K	L	M	N	P	R	OPERATING WEIGHT (Kgs)	SHIPPING WEIGHT (Kgs)	SHIPPING DIMENSIONS (L x W x H)
24APA518	0	X	0	0	0	743.0	1009.6	154.0	15.9	142.9	803.2	255.8	106.4	28.8	330.2	419.1	469.9	838.2	89.4	103.4	784.2 X 922.4 X 1173.2
24APA524	0	X	0	0	0	743.0	1009.6	154.0	15.9	142.9	803.2	255.8	106.4	28.8	300.5	381.0	444.5	838.2	89.8	103.9	784.2 X 922.4 X 1173.2
24APA530	0	X	0	0	0	901.7	943.0	160.4	19.0	173.0	730.2	295.3	101.8	28.6	450.8	489.0	457.2	1018.0	117.0	135.2	943.0 X 1100.2 X 1085.8
24APA536	0	X	0	0	0	901.7	943.0	160.4	19.0	173.0	730.2	295.3	101.8	28.6	450.8	406.4	425.4	1018.0	117.5	135.6	943.0 X 1100.2 X 1085.8
24APA542	0	X	0	0	0	901.7	1201.8	158.8	22.2	173.0	730.2	295.3	103.2	28.6	489.9	476.2	508.0	1018.0	145.1	161.0	943.0 X 1100.2 X 1280.8
24APA548	0	X	0	0	0	901.7	1201.8	158.8	22.2	173.0	730.2	295.3	103.2	28.6	489.9	476.2	508.0	1018.0	147.9	163.7	943.0 X 1100.2 X 1280.8
24APA560	0	X	0	0	0	901.7	1201.8	158.8	22.2	173.0	730.2	295.3	103.2	28.6	400.0	533.4	539.8	1018.0	149.7	165.6	943.0 X 1100.2 X 1280.8

208-230-160	X
230-160	0
208/230-3-60	X
460-3-60	0

X = YES
0 = NO

NOTES:

1. ALLOW 762.0 CLEARANCE TO SERVICE SIDE OF UNIT, 1219.2 ABOVE UNIT, 152.4 ON ONE SIDE, 304.8 ON REMAINING SIDE, AND 609.6 BETWEEN UNITS FOR PROPER AIRFLOW.
2. MINIMUM OUTDOOR OPERATING AMBIENT IN COOLING MODE IS 13°C, MAX. 52°C.
3. SERIES DESIGNATION IS THE 13TH POSITION OF THE UNIT MODEL NUMBER.
4. CENTER OF GRAVITY 
5. ALL DIMENSIONS ARE IN "MM" UNLESS NOTED.

6

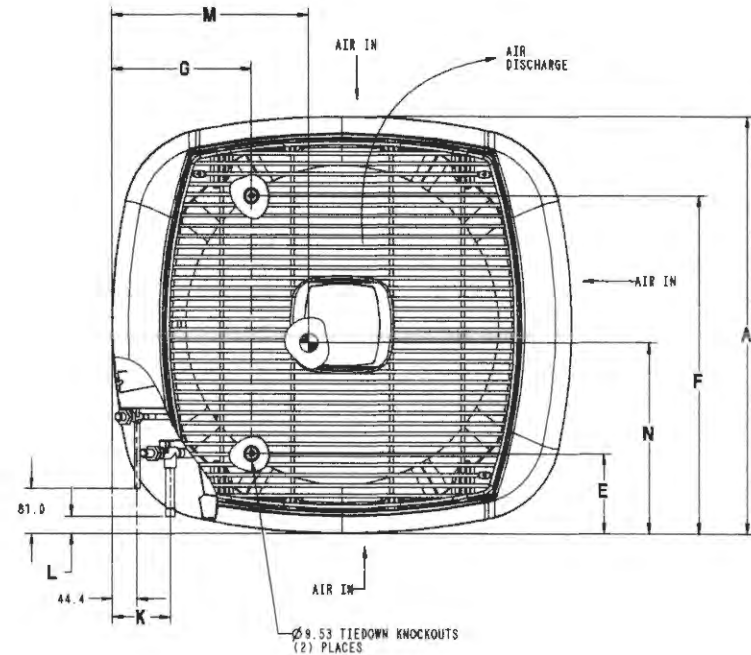
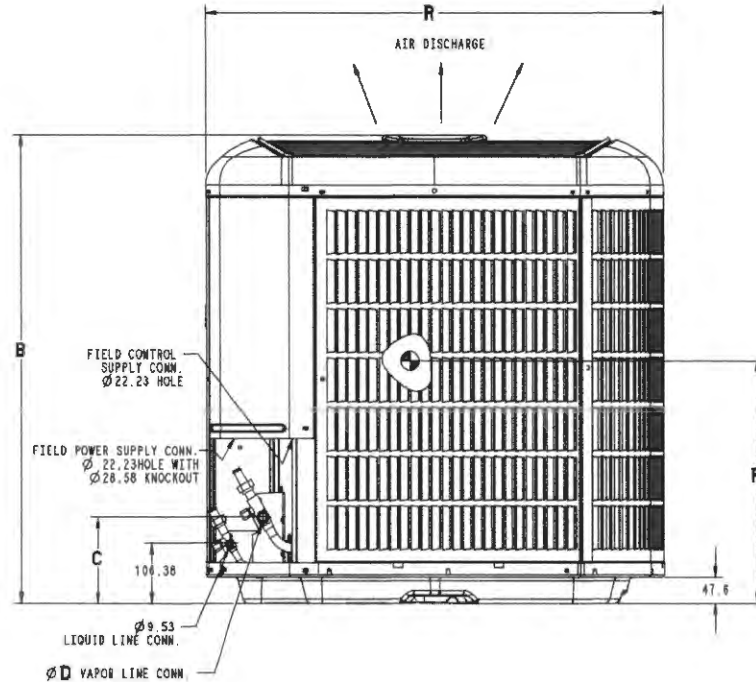

UNIT SIZE	MINIMUM MOUNTING PAD DIMENSIONS
18, 24	749.3 X 838.2
30, 36, 42, 48, 60	927.1 X 1016.0

24APA5

PHYSICAL DATA

UNIT SIZE SERIES	18-30	24-30	30-30	36-30	42-30	48-30	60-30
Operating Weight lb (kg)	197 (89.4)	198 (89.8)	258 (117.0)	259 (117.5)	320 (145.1)	326 (147.9)	330 (149.7)
Shipping Weight lb (kg)	228 (103.4)	229 (103.9)	298 (135.2)	299 (135.6)	355 (161.0)	361 (163.7)	365 (165.6)
Compressor Type	Scroll						
REFRIGERANT	Puron® (R-410A)						
Control	TXV (Puron® Hard Shutoff)						
Charge lb (kg)	5.28 (2.39)	5.66 (2.57)	10.77 (4.89)	10.03 (4.55)	10.80 (4.90)	11.40 (5.17)	13.17 (5.97)
COND FAN	Forward Swept, Propeller Type, Direct Drive						
Air Discharge	Vertical						
Air Qty (CFM)	2140	2140	2595	3265	3265	3673	3673
Motor HP	1/12	1/12	1/10	1/6	1/6	1/4	1/4
Motor RPM	800	800	800	800	800	800	800
COND COIL							
Face Area (Sq ft)	16.08	16.08	18.30	18.30	24.40	24.40	24.40
Fins per In.	25	25	20	20	20	20	20
Rows	1	1	2	2	2	2	2
Circuits	4	4	6	6	8	8	8
VALVE CONNECT. (In. ID)							
Vapor	5/8	5/8	3/4	3/4	7/8	7/8	7/8
Liquid	3/8						
REFRIGERANT TUBES (In. OD)							
Rated Vapor*	5/8	5/8	3/4	3/4	7/8	7/8	1-1/8
Liquid	3/8						

*Units are rated with 25 ft (7.6 m) of lineset length. See Vapor Line Sizing and Cooling Capacity Loss table when using other sizes and lengths of lineset.

NOTE: See unit Installation Instruction for proper installation.

24APAS

VAPOR LINE SIZING AND COOLING CAPACITY LOSS

LONG LINE APPLICATION: An application is considered "Long line" when the total equivalent tubing length exceeds 80 ft. (24.38 m) or when there is more than 20 ft. (6.09 m) vertical separation between indoor and outdoor units. These applications require additional accessories and system modifications for reliable system operation. The maximum allowable total equivalent length is up to 250 ft. (76.2 m). The maximum

vertical separation is 200 ft. (60.96 m) when outdoor unit is above indoor unit, and up to 80 ft. (24.38 m) when the outdoor unit is below the indoor unit. Refer to Accessory Usage Guideline below for required accessories. See Longline Application Guideline for required piping and system modifications. Also, refer to the table below for the vapor tube diameters based on the total length to minimize the cooling capacity loss.

Unit Nominal Size (Btuh)	Maximum Liquid Line Diameters (In. OD)	Vapor Line Diameters (In. OD)	Cooling Capacity Loss (%)								
			Total Equivalent Line Length ft. (m)								
			Standard Application			Long Line Application Requires Accessories					
26-50 (7.9-15.2)	51-80 (15.5-24.4)	81-100 (24.7-30.5)	101-125 (30.8-38.1)	126-150 (38.4-45.7)	151-175 (46.0-53.3)	176-200 (53.6-61.0)	201-225 (61.3-68.6)	226-250 (68.9-76.2)			
18000 1 Stage Puron AC	3/8	1/2	1	2	3	4	6	7	8	9	10
		5/8	0	0	1	1	1	2	2	3	3
24000 1 Stage Puron AC	3/8	5/8	0	1	1	2	3	3	4	4	5
		3/4	0	0	0	0	1	1	1	1	1
30000 1 Stage Puron AC	3/8	7/8	0	0	0	0	0	0	0	0	0
		5/8	1	2	3	3	4	5	6	7	8
36000 1 Stage Puron AC	3/8	3/4	0	0	1	1	1	2	2	2	3
		7/8	0	0	0	0	1	1	1	1	1
42000 1 Stage Puron AC	3/8	5/8	1	2	4	5	6	8	9	10	12
		3/4	0	1	1	2	2	3	3	4	4
48000 1 Stage Puron AC	3/8	7/8	0	0	0	0	1	1	1	2	2
		3/4	0	1	2	2	3	4	5	5	6
60000 1 Stage Puron AC	3/8	1 1/8	0	0	0	0	0	0	0	0	0
		7/8	0	0	1	1	2	2	2	3	3
		3/4	1	2	4	5	6	7	9	10	11
		7/8	0	1	2	2	3	4	4	5	5
		1 1/8	0	0	0	1	1	1	1	1	1

Applications in this area are long line. Accessories are required as shown recommended on Long Line Application Guidelines

Applications in this area may have height restrictions that limit allowable total equivalent length, when outdoor unit is below indoor unit. See Long Line Application Guidelines

11/22/2010 7:44:31 AM

Customer	General Information	Miscellaneous	Reference Code
Customer# 1732 CHRISTMAN POOL SERVICE 123 GRAY RD. FALMOUTH, ME 04105	Contact: KEVIN DOREE Business: 207-797-3751 OFFICE 207-797-0366 FAX 207-650-1790 CELL		

Customer Count: 1

JOB ADDRESS

*336 WARREN AVE
PORTLAND, ME. 04103*