

City of Portland, Maine - Building or Use Permit Application
 389 Congress Street, 04101 Tel: (207) 874-8703, Fax: (207) 874-8716

PERMIT ISSUED

Permit No: 02-0863 Issue Date: 12 2002 CBL: 300 C012001

Location of Construction: 43 Elbert St	Owner Name: Bouhel Valerie &	Owner Address: 43 Elbert St	Phone: 207-878-2514
Business Name:	Contractor Name: Applicant	Contractor Address: Portland	Phone:
Lessee/Buyer's Name	Phone:	Permit Type: Alterations - Dwellings	Zone: R-3

Past Use: Office, catch all - 3 season <i>No business use permitted</i>	Proposed Use: 4-season den <i>single family use only</i>	Permit Fee: \$30.00	Cost of Work: \$1,000.00	CEO District: 1	5980 ⁺
		FIRE DEPT: <i>N/A</i>	INSPECTION: Use Group: R-3 Type: SB BOCA 99		

Proposed Project Description:
Replace windows/relocate door/insulate

Signature: _____ Signature: *[Signature]*

PEDESTRIAN ACTIVITIES DISTRICT (P.A.D.)
 Action: Approved Approved w/Conditions Denied
 Signature: _____ Date: _____

Permit Taken By: jmy	Date Applied For: 08/01/2002	Zoning Approval	
-------------------------	---------------------------------	------------------------	--

1. This permit application does not preclude the Applicant(s) from meeting applicable State and Federal Rules. 2. Building permits do not include plumbing, septic or electrical work. 3. Building permits are void if work is not started within six (6) months of the date of issuance. False information may invalidate a building permit and stop all work..	Special Zone or Reviews <input type="checkbox"/> Shoreland <input type="checkbox"/> Wetland <input type="checkbox"/> Flood Zone <input type="checkbox"/> Subdivision <input type="checkbox"/> Site Plan Maj <input type="checkbox"/> Minor <input type="checkbox"/> MM <input type="checkbox"/> Date: <i>8/6/02</i>	Zoning Appeal <input type="checkbox"/> Variance <input type="checkbox"/> Miscellaneous <input type="checkbox"/> Conditional Use <input type="checkbox"/> Interpretation <input type="checkbox"/> Approved <input type="checkbox"/> Denied Date: _____	Historic Preservation <input checked="" type="checkbox"/> Not in District or Landmark <input type="checkbox"/> Does Not Require Review <input type="checkbox"/> Requires Review <input type="checkbox"/> Approved <input type="checkbox"/> Approved w/Conditions <input type="checkbox"/> Denied Date: <i>[Signature]</i>
--	---	---	---

CERTIFICATION

I hereby certify that I am the owner of record of the named property, or that the proposed work is authorized by the owner of record and that I have been authorized by the owner to make this application as his authorized agent and I agree to conform to all applicable laws of this jurisdiction. In addition, if a permit for work described in the application is issued, I certify that the code official's authorized representative shall have the authority to enter all areas covered by such permit at any reasonable hour to enforce the provision of the code(s) applicable to such permit.

 SIGNATURE OF APPLICANT ADDRESS DATE PHONE

 RESPONSIBLE PERSON IN CHARGE OF WORK, TITLE DATE PHONE

DISPLAY THIS CARD ON PRINCIPAL FRONTAGE OF WORK CITY OF PORTLAND

BUILDING DEPARTMENT

PERMIT

Permit Number: 020863

Please Read Application And Notes, If Any, Attached

This is to certify that Bouhel Valerie &/Applicant
has permission to Replace windows/relocate door insulate
AT 43 Elbert St 300 C012001

provided that the person or persons, firm or corporation accepting this permit shall comply with all of the provisions of the Statutes of Maine and of the ordinances of the City of Portland regulating the construction, maintenance and use of buildings and structures, and of the application on file in this department.

Apply to Public Works for street line and grade if nature of work requires such information.

Notification of inspection must be given and work on permit in progress before this building or part thereof is closed or enclosed-in. 24 HOUR NOTICE IS REQUIRED.

A certificate of occupancy must be procured by owner before this building or part thereof is occupied.

OTHER REQUIRED APPROVALS

Fire Dept. _____
Health Dept. _____
Appeal Board _____
Other _____
Department Name

Director - Building & Inspection Services

PENALTY FOR REMOVING THIS CARD

2-0863

Zoning

Approved with Conditions

Marge Schmuckal

43 Elbert Street

08/06/2002

08/03/2002



Marge Schmuckal

08/06/2002

This property shall remain a single family dwelling. Any change of use shall require a separate permit application for review and approval.

This is NOT an approval for an additional dwelling unit. You SHALL NOT add any additional kitchen equipment including, but not limited to items such as stoves, microwaves, refrigerators, or kitchen sinks, etc. Without special approvals.

Your present structure is legally nonconforming as to setbacks. If you are to demolish this structure on your own volition, you will only have one (1) year to replace it in the same footprint (no expansions), with the same height, and same use. Any changes to any of the above shall require that this structure meet the current zoning standards.

If there is to be a home occupation within this single family use, then it is required to apply for a separate permit explaining that use and how it meets the given criteria. See informational handout attached to these conditions.

08/01/2002

jmy

08/06/2002

mes

02-0863

All Purpose Building Permit Application

If you or the property owner owes real estate or personal property taxes or user charges on any property within the City, payment arrangements must be made before permits of any kind are accepted.

Location/Address of Construction: <u>43 Elbert Street</u>		
Total Square Footage of Proposed Structure <u>119 sq ft</u>	Square Footage of Lot <u>3185 sq ft</u>	
Tax Assessor's Chart, Block & Lot Chart# <u>300</u> Block# <u>C</u> Lot# <u>12</u>	Owner: <u>Jonathan & Valerie Boubel (Shuttleworth)</u>	Telephone: <u>878 2514</u>
Lessee/Buyer's Name (If Applicable)	Applicant name, address & telephone: <u>Valerie Boubel 43 Elbert St 878 2514 Portland ME, 04103</u>	Cost Of Work: \$ <u>800 - 1000</u> Fee: \$ <u>30.00</u>
Current use: <u>office, catch all - 3 season</u>		* Tax & lot info may be under the last name of Shuttleworth Valerie & William
If the location is currently vacant, what was prior use: _____		
Approximately how long has it been vacant: _____		
Proposed use: <u>4-season den</u>		
Project description: <u>replace windows, relocate door, insulate</u>		
Contractor's name, address & telephone: <u>Doing work as home owners</u>		
Who should we contact when the permit is ready: <u>owner - Valerie Boubel & M</u>		
Mailing address: _____		
We will contact you by phone when the permit is ready. You must come in and pick up the permit and review the requirements before starting any work, with a Plan Reviewer. A stop work order will be issued and a \$100.00 fee if any work starts before the permit is picked up. PHONE: <u>878 2514 & call</u>		

IF THE REQUIRED INFORMATION IS NOT INCLUDED IN THE SUBMISSIONS THE PERMIT WILL BE AUTOMATICALLY DENIED AT THE DISCRETION OF THE BUILDING/PLANNING DEPARTMENT, WE MAY REQUIRE ADDITIONAL INFORMATION IN ORDER TO APPROVE THIS PERMIT.

I hereby certify that I am the Owner of record of the named property, or that the owner of record authorizes the proposed work and that I have been authorized by the owner to make this application as his/her authorized agent. I agree to conform to all applicable laws of this jurisdiction. In addition, if a permit for work described in this application is issued, I certify that the Code Official's authorized representative shall have the authority to enter all areas covered by this permit at any reasonable hour to enforce the provisions of the codes applicable to this permit.

Signature of applicant: <u>Valerie Boubel</u>	Date: <u>8-1-02</u>
---	---------------------

This is NOT a permit, you may not commence ANY work until the permit is issued. If you are in a Historic District you may be subject to additional permitting and fees with the Planning Department on the 4th floor of City Hall

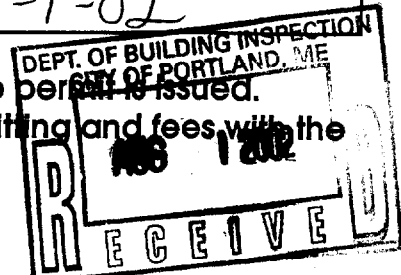

Existing Structure

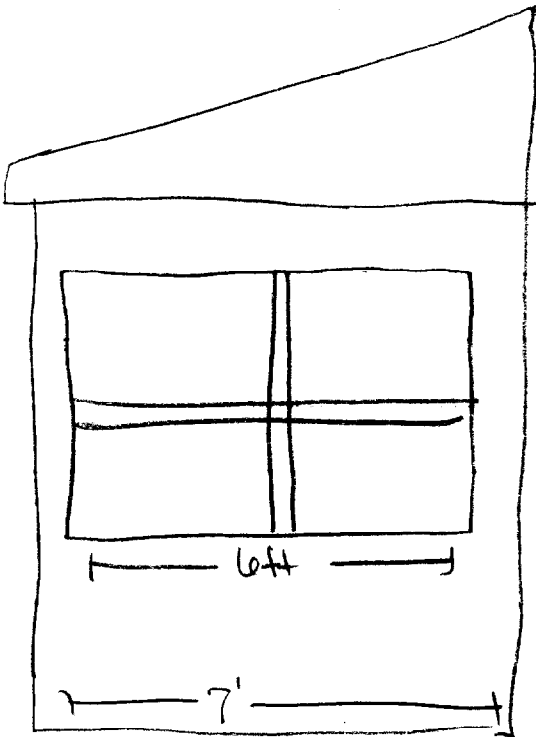
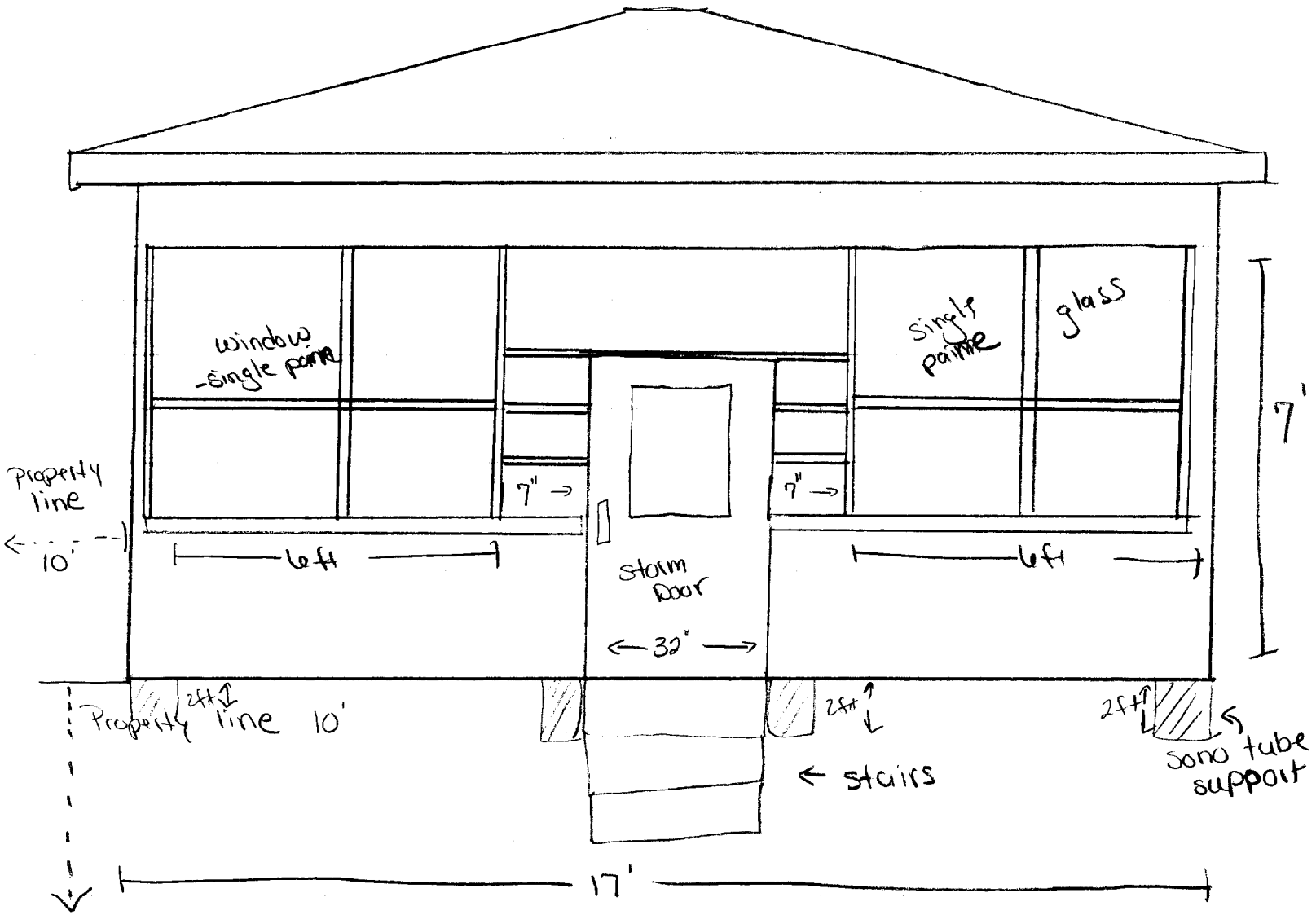

side view

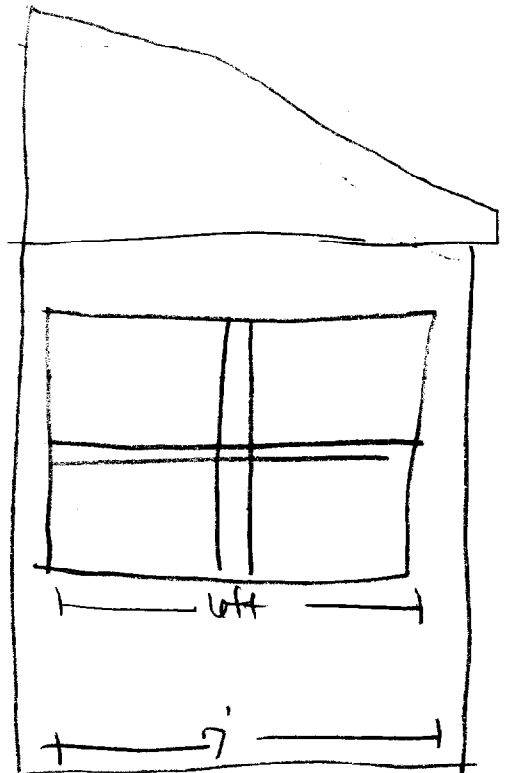

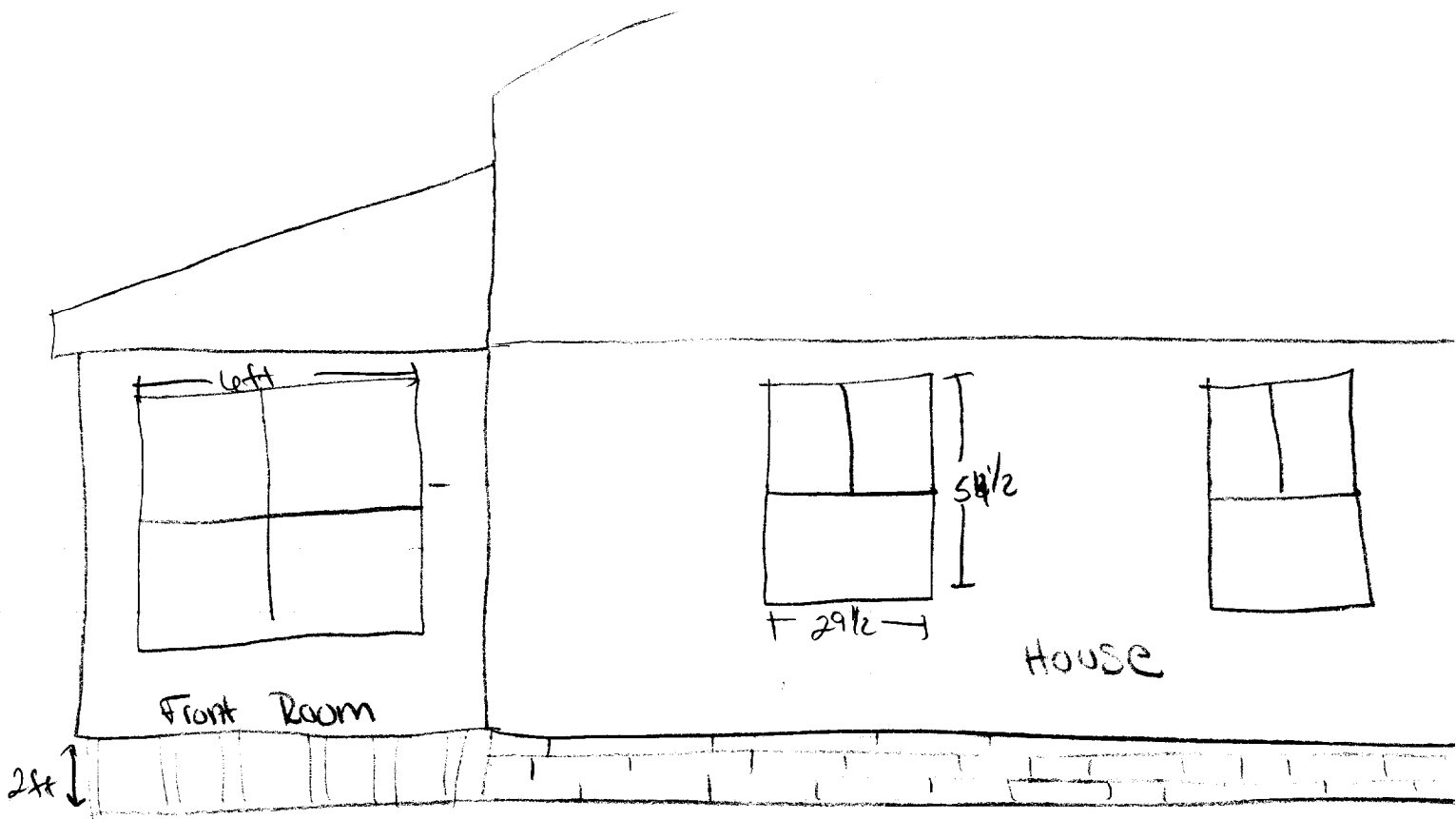

Existing structure

New Structure

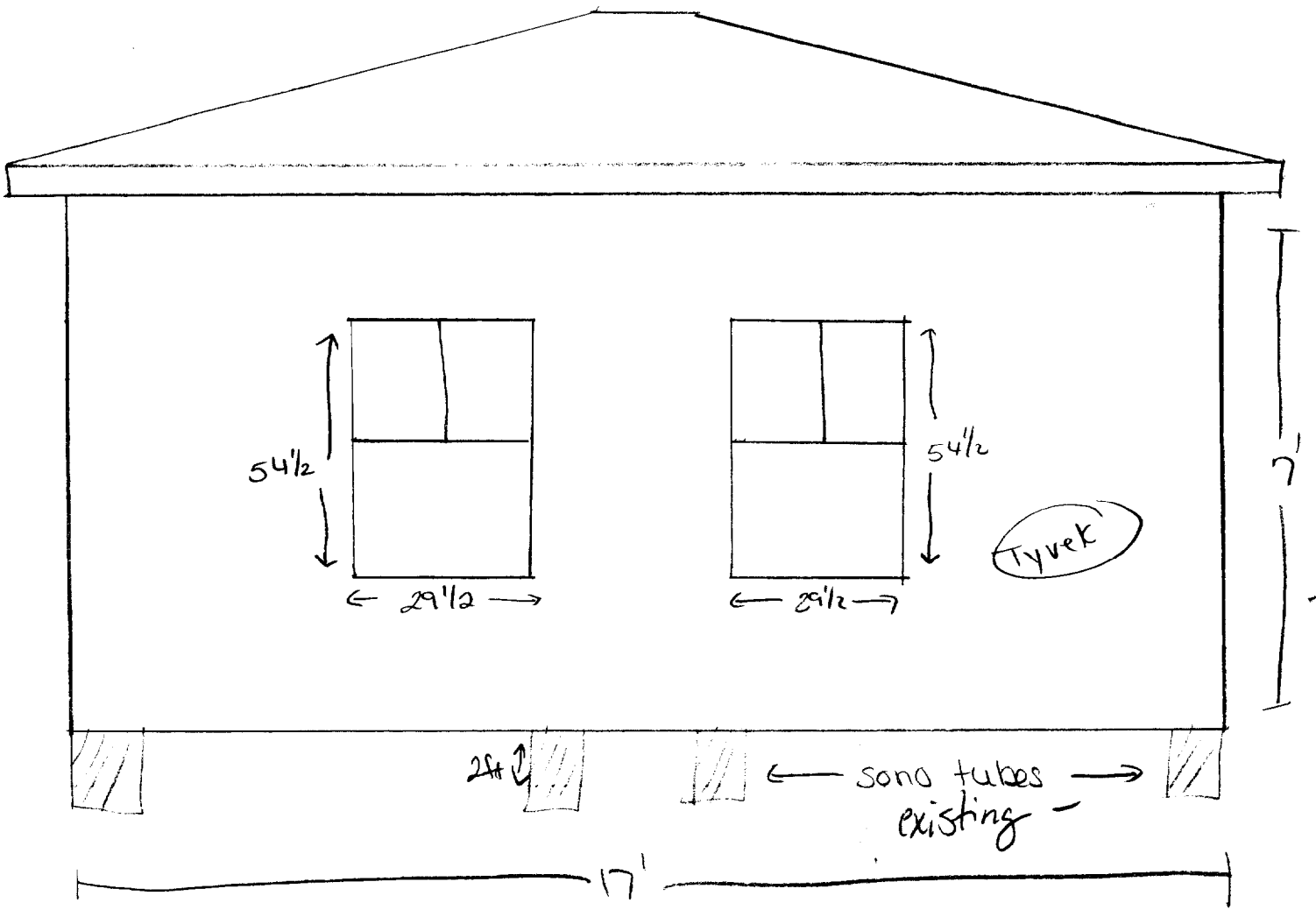

* replacing windows
- removing door

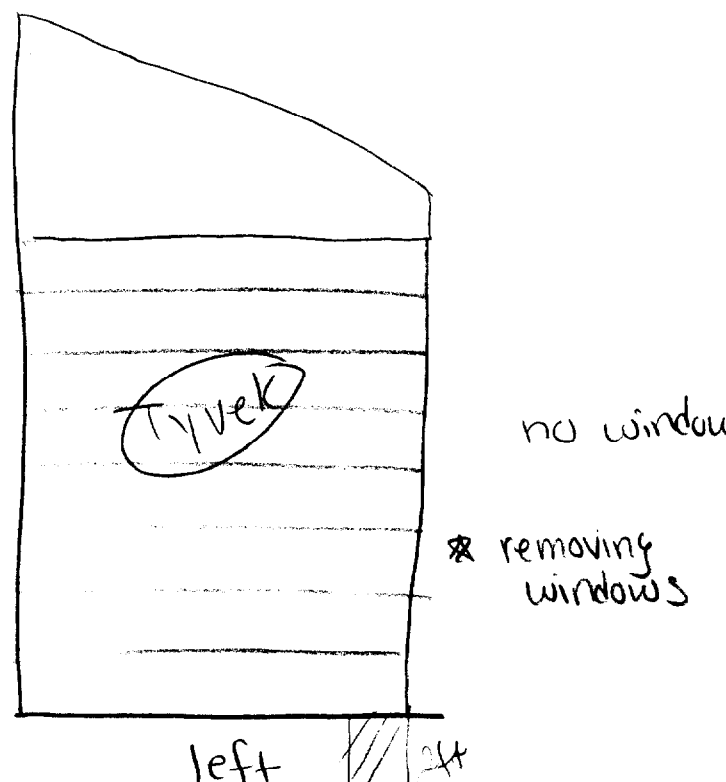
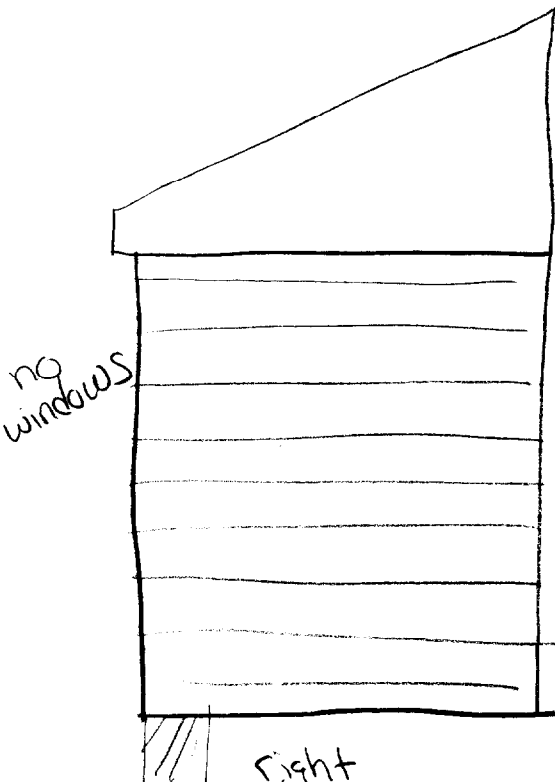

new structure

Insulation
between
2x4's

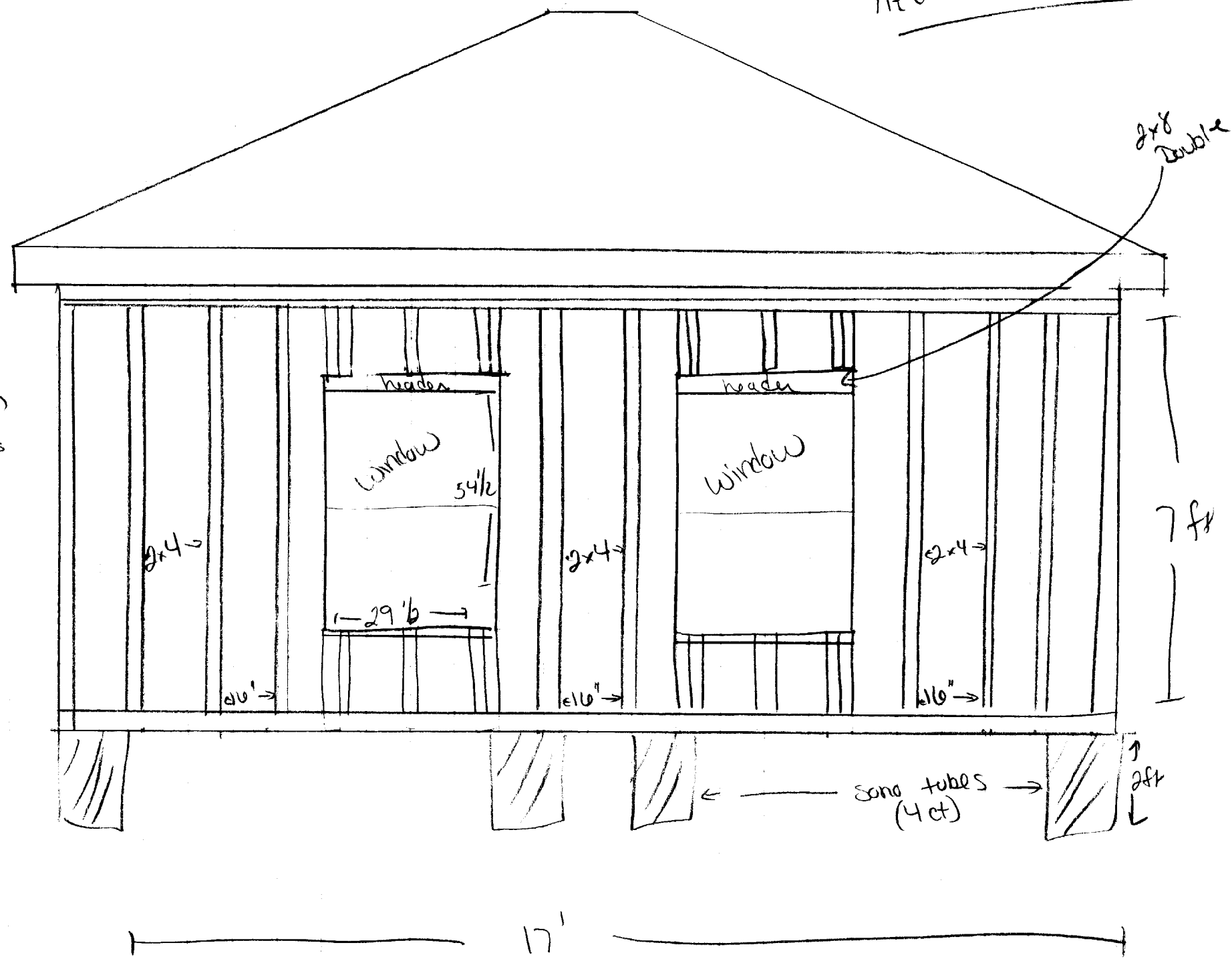

2x8
Double

7 ft

sonotubes
(4 ct)

17'

House Lot

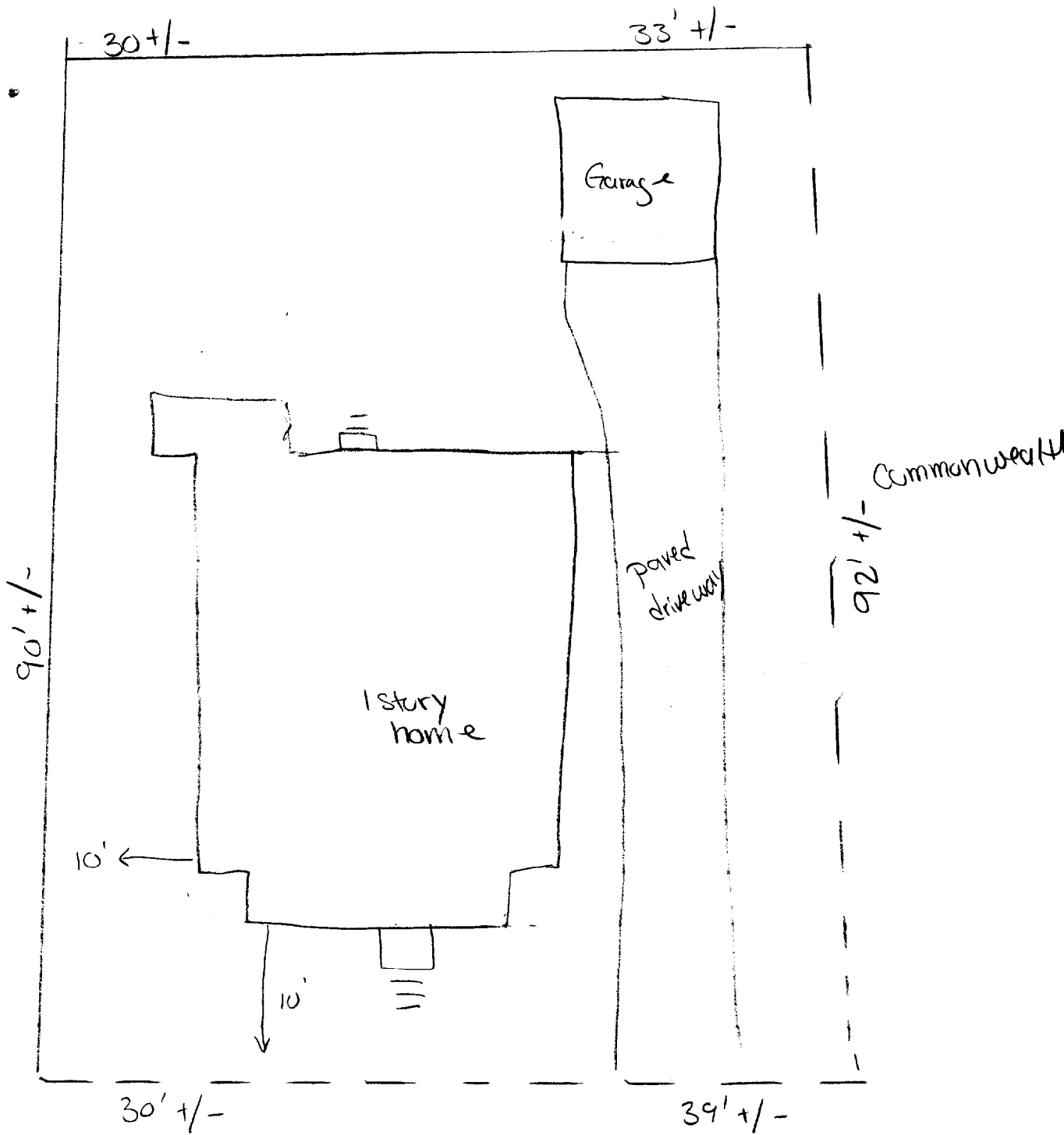

Elbert

Top View
- new structure

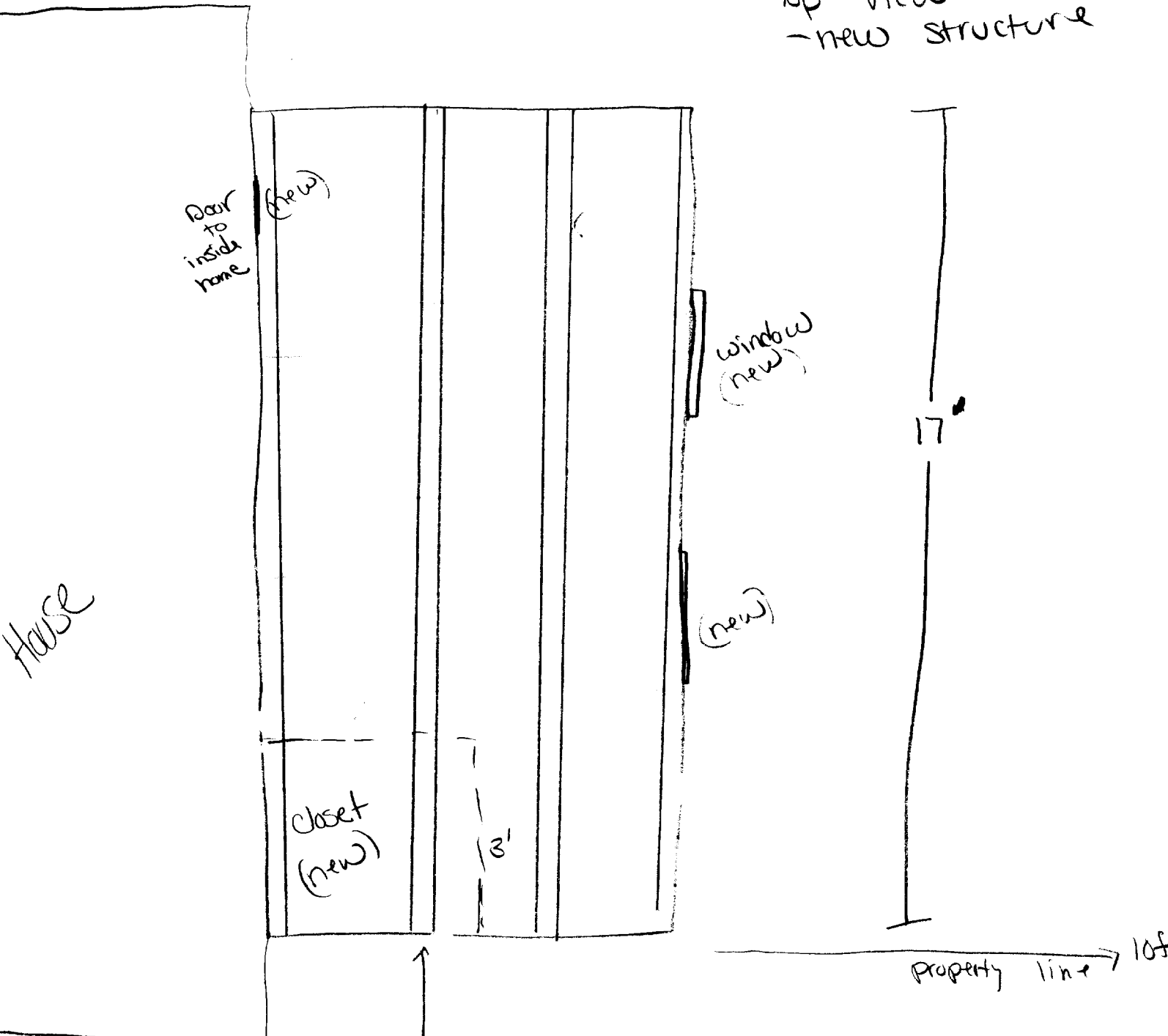

House

Door to inside home (new)

Window (new)

(new)

closet (new)

13'

17'

Property line → 10ft

10' Property line ↓

Floor Joists

* Floor Support already exists
→ placing sub-flooring over wood planks

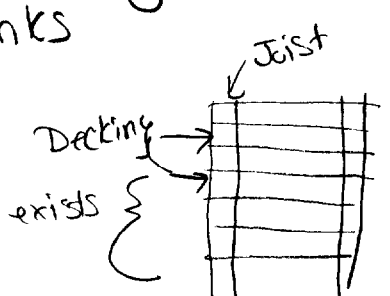

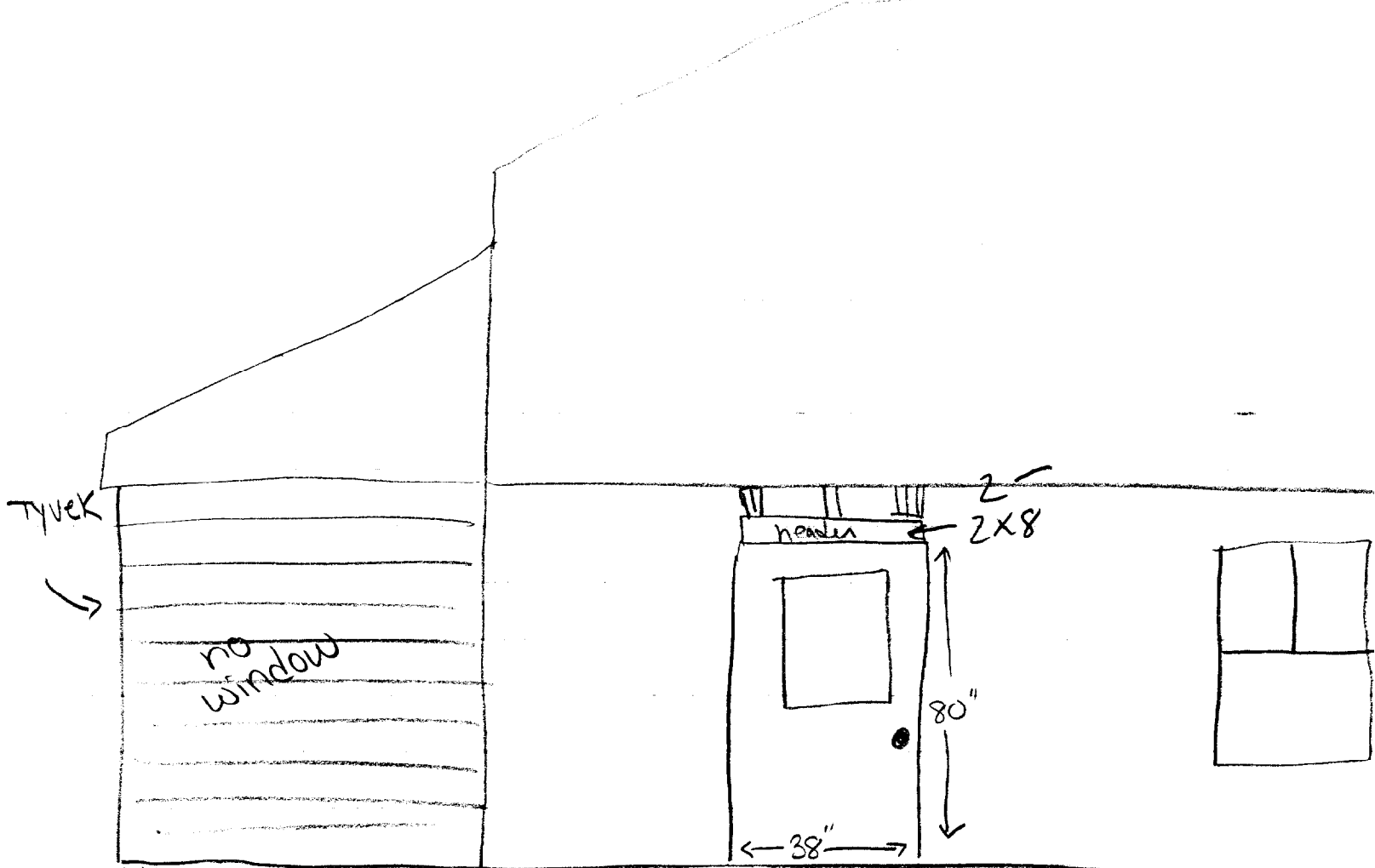

relocate stairs w/ small platform

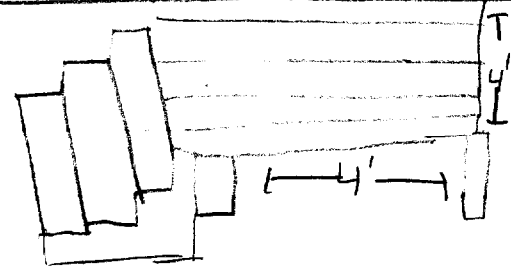

using opening where window was

New structure

STAIRS
(Pressure treated lumber)

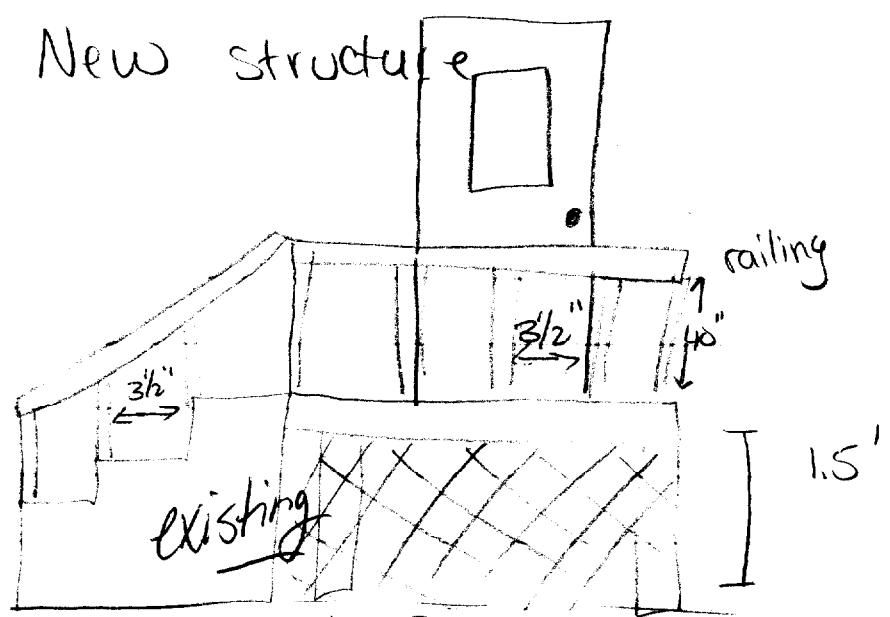

2-3 steps

Posts on concrete supports

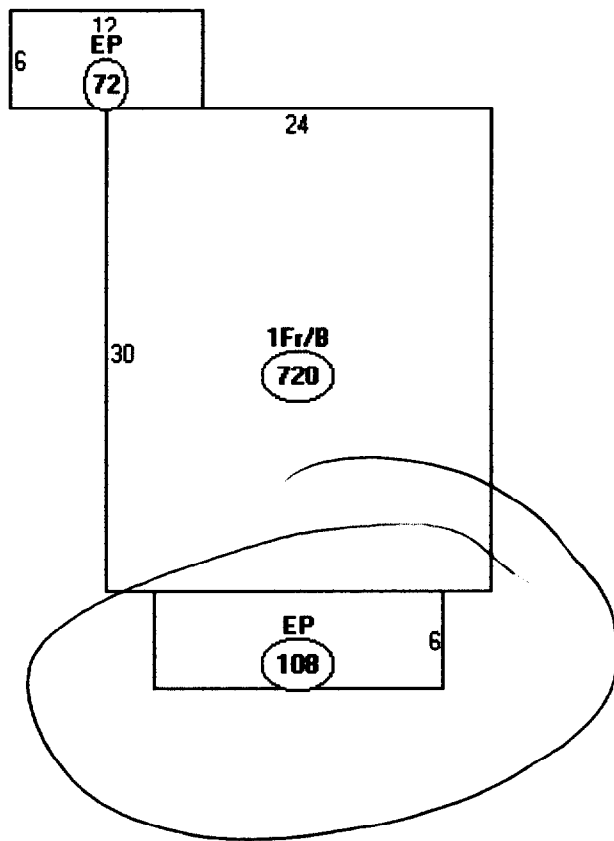

Descriptor/Area
A: 1Fr/B
720 sqft
B: EP
72 sqft
C: EP
108 sqft



BUILDING PERMIT INSPECTION PROCEDURES

Please call 874-8703 or 874-8693 to schedule your inspections as agreed upon

Permits expire in 6 months, if the project is not started or ceases for 6 months.

The Owner or their designee is required to notify the inspections office for the following inspections and provide adequate notice. Notice must be called in 48-72 hours in advance in order to schedule an inspection:

By initializing at each inspection time, you are agreeing that you understand the inspection procedure and additional fees from a "Stop Work Order" and "Stop Work Order Release" will be incurred if the procedure is not followed as stated below.

 Pre-construction Meeting: Must be scheduled with your inspection team upon receipt of this permit. Jay Reynolds, Development Review Coordinator at 874-8632 must also be contacted at this time, before any site work begins on any project other than single family additions or alterations.

N/A **Footing/Building Location Inspection:** Prior to pouring concrete

N/A **Re-Bar Schedule Inspection:** Prior to pouring concrete

N/A **Foundation Inspection:** Prior to placing ANY backfill

Call **Framing/Rough Plumbing/Electrical:** Prior to any insulating or drywalling

Call **Final/Certificate of Occupancy:** Prior to any occupancy of the structure or use. **NOTE:** There is a \$75.00 fee per inspection at this point. NO CO

Certificate of Occupancy is not required for certain projects. Your inspector can advise you if your project requires a Certificate of Occupancy. All projects DO require a final inspection

 If any of the inspections do not occur, the project cannot go on to the next phase, REGARDLESS OF THE NOTICE OR CIRCUMSTANCES.

 CERIFICATE OF OCCUPANICES MUST BE ISSUED AND PAID FOR, BEFORE THE SPACE MAY BE OCCUPIED

Valeri Barbud
Signature of applicant/designee

8-12-02
Date

Jay Reynolds
Signature of Inspections Official

8/12/02
Date

CBL: 300 C 012 Building Permit #: 020863