



**INSTALLATION, OPERATION & MAINTENANCE MANUAL**  
**ENERGY RECOVERY VENTILATOR**

HE1.5XIN



MODEL: HE1.5XINH SHOWN



**ABOUT RENEWAIRE**

For over 30 years, RenewAire has been a pioneer in enhancing indoor air quality (IAQ) in commercial and residential buildings of all sizes. This is achieved while maximizing sustainability through fifth-generation, enthalpic-core, static-plate Energy Recovery Ventilators (ERVs) that improve energy efficiency, lower capital costs via load reduction and decrease operational expenses by minimizing equipment needs, resulting in significant energy savings. Our ERVs are competitively priced, simple to install, easy to use and maintain and have a quick payback. They also enjoy the industry's lowest warranty claims due to long-term reliability derived from innovative design practices, expert workmanship and Quick Response Manufacturing (QRM).

As the first producer of static-plate core technology in North America, RenewAire presently has over 180,000 units in operation and is now one of the largest ERV companies in the world. We're committed to sustainable manufacturing and lessening our environmental footprint, and to that end our Madison, WI plant is 100% powered by wind turbines. The facility is also one of the few buildings worldwide to be LEED- and Green Globes-certified, as well as having achieved ENERGY STAR Building status. In 2010, RenewAire joined the Soler & Palau (S&P) Ventilation Group in order to provide direct access to the latest in HVAC technologies. For more information, visit: [www.renewaire.com](http://www.renewaire.com).

**TABLE OF CONTENTS**

HE1.5XIN info ..... 2-5  
 Installation ..... 6-15  
 Start-up ..... 16-17  
 Maintenance ..... 18-19

**HE1.5XIN INFO**

**HE1.5X CONFIGURATION CHART**

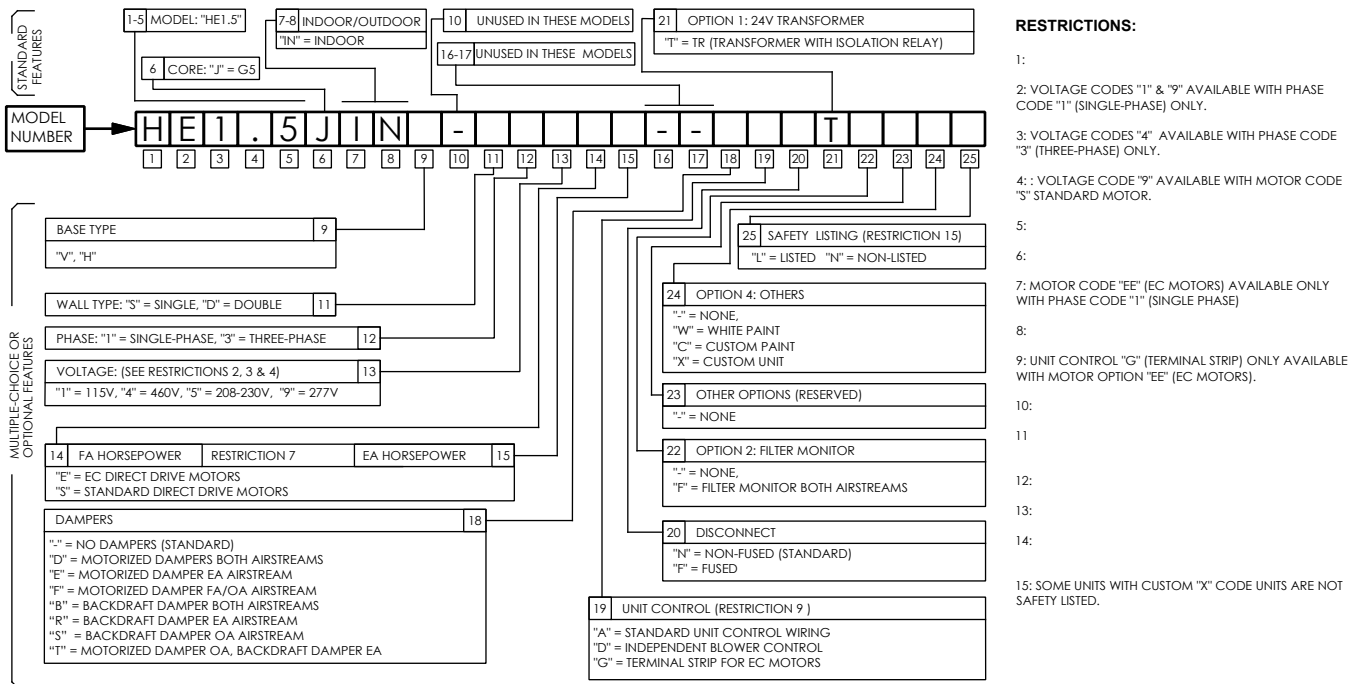

**NOTE:** RenewAire reserves the right to make changes in the design or specifications of products at any time without notice. Unless otherwise specified, dimensions are rounded to the nearest eighth of an inch.

HE1.5XIN INFO

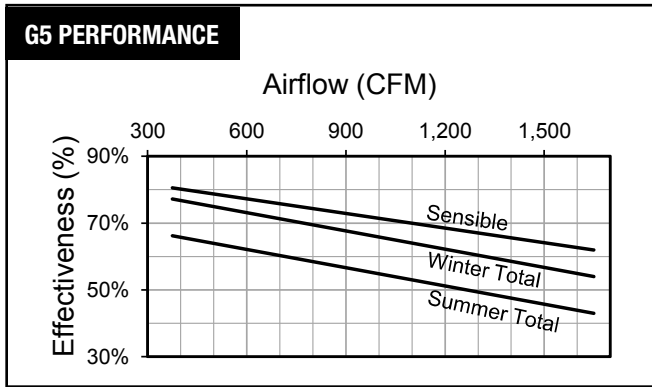

**VENTILATION TYPE**  
Static Plate, Heat and Humidity Transfer

**SPECIFICATIONS**

**NOTE:** Specifications may be subject to change without notice.

Unless otherwise specified, dimensions are rounded to the nearest eighth of an inch.

For the latest product information available visit our website at [renewaire.com](http://renewaire.com) or call us at 800-627-4499

**FEATURES**

**Orientations:**

Horizontal - HE1.5XINH  
Vertical - HE1.5XINV

**Typical Airflow Range:**

375-1,575 CFM

**AHRI 1060 Certified Core:**

One L62 and one L125

**Standard Features:**

Non-fused Disconnect  
24 VAC Transformer/Relay Package

**Filters:**

Four total, MERV 8, 2" pleated, 14" x 20" (2) and 16" x 20" (2) nominal size

**Weight:**

340 lbs (unit), 400 lbs (shipping weight on pallet)

**Shipping Dimensions:**

63" L x 48" W x 60" H

**Options:**

EC Motor – Two, 115V or 208-230V  
1.0 hp (Single Phase)  
Fused Disconnect  
Double Wall Construction  
Gravity backdraft dampers  
Motorized isolation dampers, OA, EA or both airstreams  
Factory mounted Filter Alarms (2)  
Independent Blower Control  
MERV 13 Filters

**Accessories:**

Back Draft Dampers

MOTORS : Two Direct drive motorized impeller packages					
V	HZ	PHASE	FLA (per motor)	Min. Cir. Amps	Max. Overcurrent Protective Device
115	60	Single	6.5	14.6	20
208-230	60	Single	3.3-3.4	7.7	15
277	60	Single	2.7	6.1	15
208-230	60	Three	2.2-2.2	5.0	15
460	60	Three	1.1	2.5	15

**SUPPLEMENTAL MANUALS AVAILABLE FOR THE HE1.5XIN**

ECM Option  
Factory Installed Optional Dampers  
Filter Alarms  
Controls  
Commercial Unit Start-Up

AIRFLOW PERFORMANCE*							
Motor HP Phase	External Static pressure (inches Water Column)						
	0.0	0.25	0.50	0.75	1.00	1.25	1.50
1.0 Single Phase	1,575 CFM 1,545 Watts	1,470 CFM 1,525 Watts	1,350 CFM 1,500 Watts	1,225 CFM 1,475 Watts	1,090 CFM 1,435 Watts	950 CFM 1,380 Watts	795 CFM 1,300 Watts
1.0 Three Phase	1,675 CFM 1,410 Watts	1,570 CFM 1,400 Watts	1,435 CFM 1,380 Watts	1,280 CFM 1,340 Watts	1,115 CFM 1,280 Watts	940 CFM 1,210 Watts	760 CFM 1,135 Watts

\* Performance Ratings assume standard-equipment 2" MERV-8 filters in clean condition.

HE1.5XIN INFO

PRODUCT DIMENSIONS  
HE1.5XINH

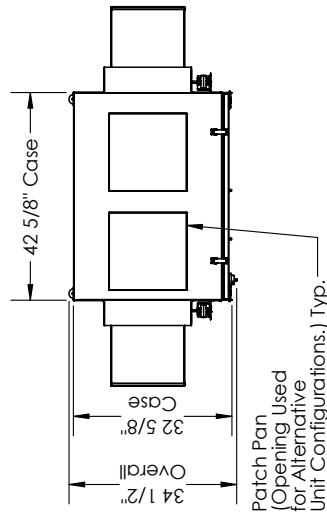

ABBREVIATIONS

- EA Exhaust Air to outside
- OA Outside Air intake
- RA Room Air to be exhausted
- FA Fresh Air to inside

NOTE:

1. Unless otherwise specified, dimensions are rounded to the nearest eighth of an inch.
2. Specifications may be subject to change without notice.

TOP VIEW

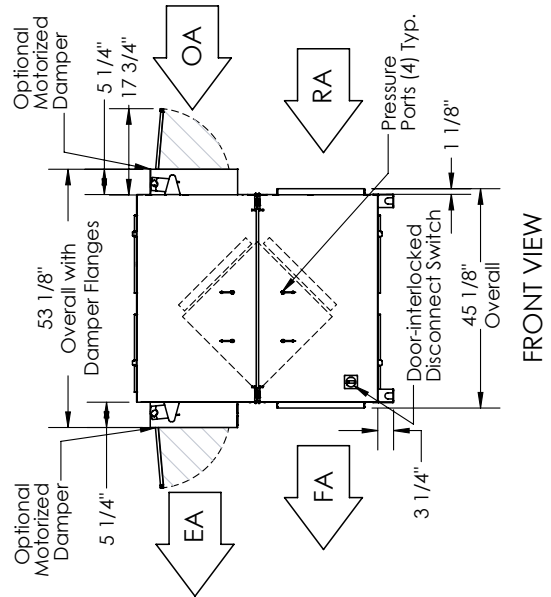

FRONT VIEW

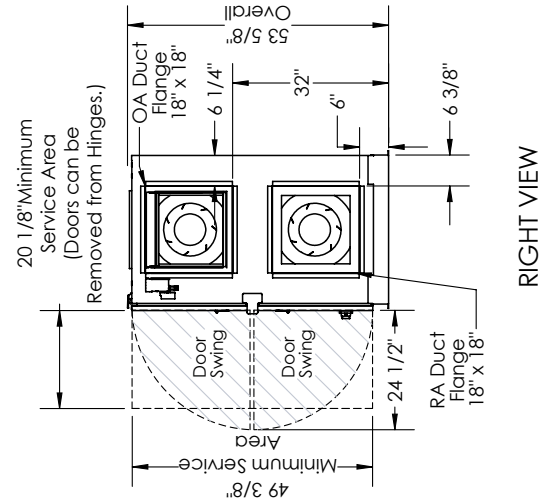

RIGHT VIEW

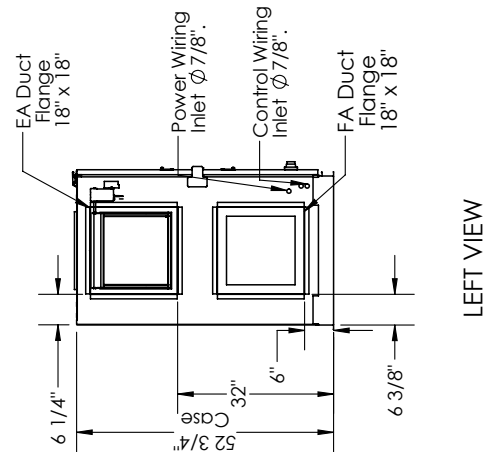

LEFT VIEW

HE1.5XIN INFO

PRODUCT DIMENSIONS  
HE1.5XINV

ABBREVIATIONS

- EA Exhaust Air to outside
- OA Outside Air intake
- RA Room Air to be exhausted
- FA Fresh Air to inside

NOTE:

1. Unless otherwise specified, dimensions are rounded to the nearest eighth of an inch.
2. Specifications may be subject to change without notice.

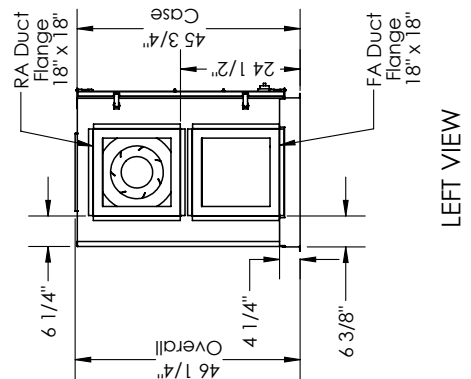
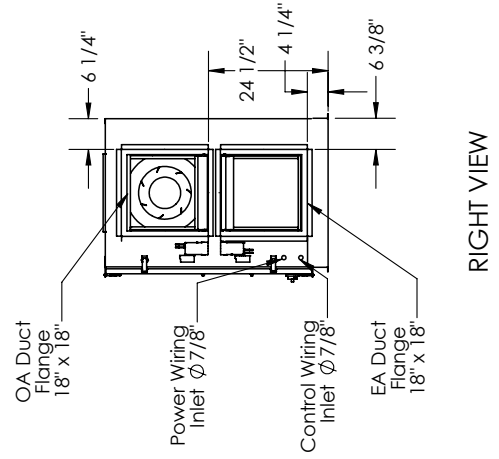
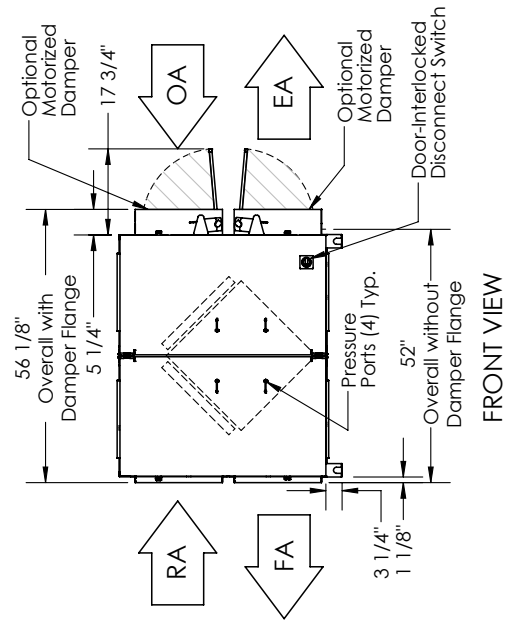
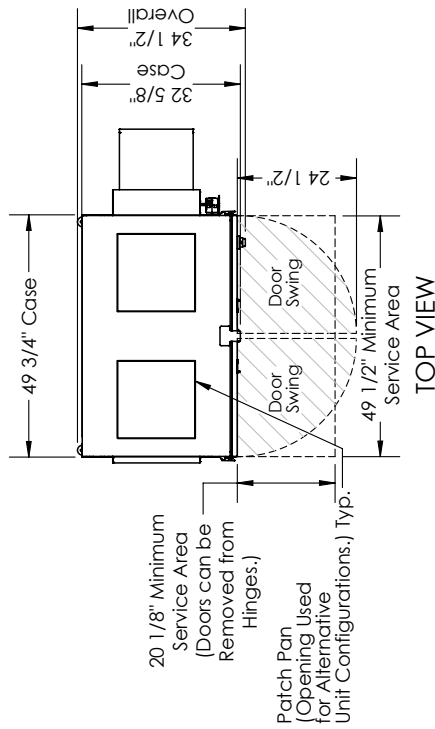

**INSTALLATION**

**PLANNING YOUR INSTALLATION**

**PLACEMENT OF THE HE1.5XIN**

The HE1.5X is designed for installation indoors. Select a location that is central to the inside duct runs, and close to both the exhaust duct (to the outside) and the fresh air duct (from the outside). The unit can be installed in any orientation but the contractor is responsible for safe installation of the unit.

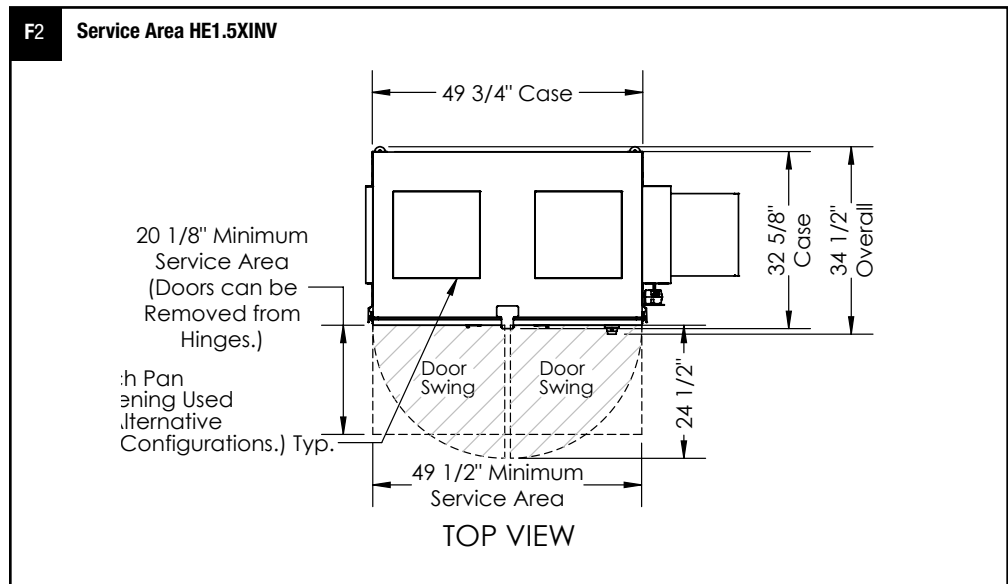
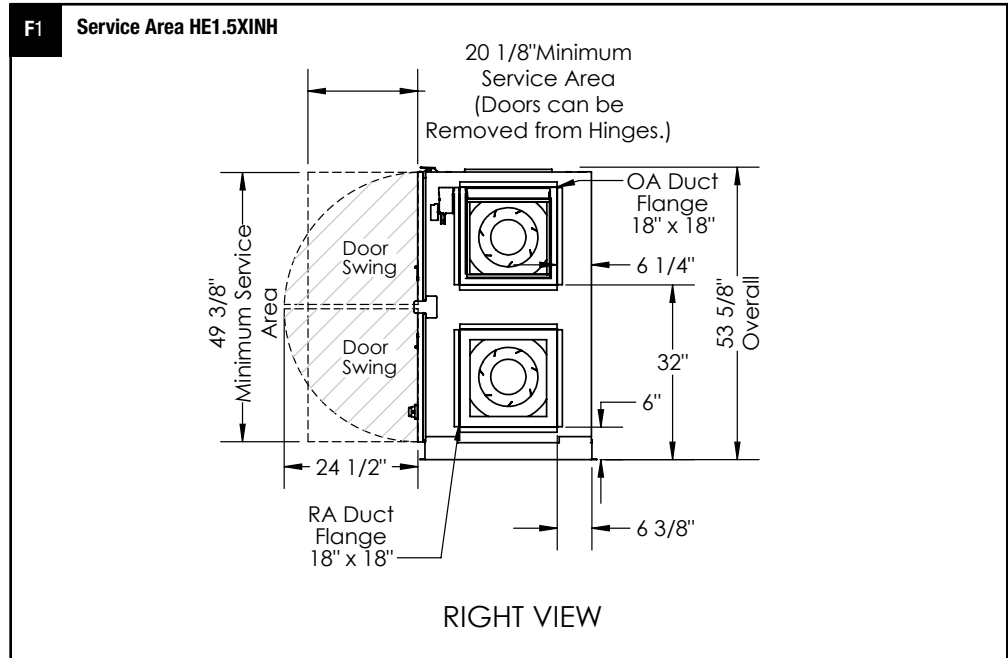

## INSTALLATION

## DUCTS TO THE OUTSIDE

The exhaust outlet and fresh air inlet on the outside of the building should be at least ten feet apart to avoid cross-contamination. The exhaust outlet should not dump air into an enclosed space or any other structure. The inlets and outlets should be screened against insects and vermin and shielded from the weather to prevent the entry of rain or snow.

**⚠ WARNING**

The fresh air inlet should be at least 10' away from chimneys, furnace and water heater exhausts, and other sources of carbon monoxide, humidity or other contamination. Do not locate the fresh air inlet where vehicles may be serviced or left idling. Never locate the fresh air inlet inside a structure.

PLANNING  
YOUR INSTALLATION

**NOTE:** To prevent the entry of rain through the outside air inlet duct, observe the following:

1. Velocity at face of inlet hood should not exceed 500 feet per minute (fpm).
2. Inlet duct must be at least 18" x 18".
3. Centerline length along duct from weather hood to unit inlet must be at least 48".
4. Inlet duct must pitch downward to the outside; centerline of inlet hood must be at least 18" below the centerline of the unit inlet.
5. Outlet duct must pitch downward to the outside with a slope of at least 1/4" to the foot.

Ducts connecting the HE1.5X to the outside must be insulated, with sealed vapor barrier on both inside and outside of the insulation. Insulate both the Outside Air (OA) and Exhaust Air (EA) ducts.

## INSIDE DUCTWORK SYSTEM

**Ensure Good Ductwork Design**

Ductwork should be designed to allow the unit to provide the required airflow and reduce pressure drop for efficient, quiet operation. If the inside ducts run through unconditioned spaces they must be insulated with a sealed vapor barrier on both inside and outside of insulation.

**Use Non-motorized Dampers to Set and Balance Air**

In most applications, the airflow rate for both the Fresh Air and the Exhaust Air should be roughly equal (or "balanced") for best performance of the HE1.5X Unit. See unit specification sheet for CFM/ESP curves.

## APPLICATIONS

See figure F3 for examples of some common installation approaches (HE1.5XINH shown).

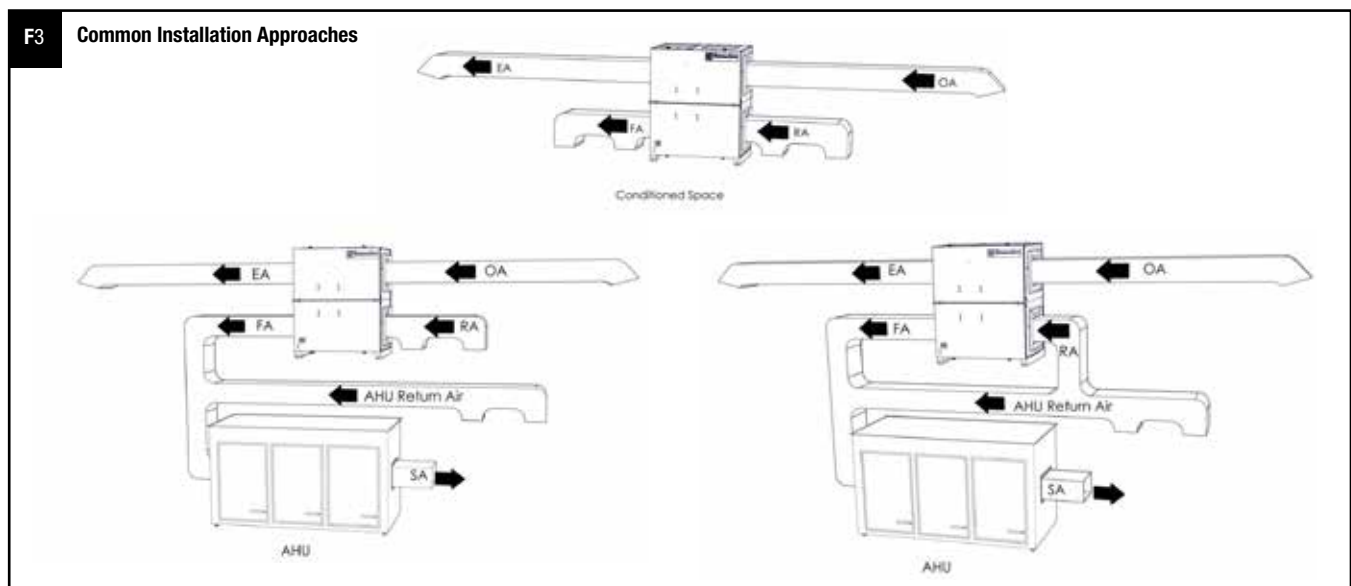

## INSTALLATION

PLANNING  
YOUR INSTALLATION **WARNING****RISK OF FIRE, ELECTRIC SHOCK, OR INJURY. OBSERVE ALL CODES AND THE FOLLOWING:**

1. Before servicing or cleaning the unit, switch power off at disconnect switch or service panel and lock-out/tag-out to prevent power from being switched on accidentally. More than one disconnect switch may be required to de-energize the equipment for servicing.
2. This installation manual shows the suggested installation method. Additional measures may be required by local codes and standards.
3. Installation work and electrical wiring must be done by qualified professional(s) in accordance with all applicable codes, standards and licensing requirements.
4. Any structural alterations necessary for installation must comply with all applicable building, health, and safety code requirements.
5. This unit must be grounded.
6. Sufficient air is needed for proper combustion and exhausting of gases through the flue (chimney) of fuel burning equipment that might be installed in the area affected by this equipment. If this unit is exhausting air from a space in which chimney-vented fuel burning equipment is located, take steps to assure that combustion air supply is not affected. Follow the heating equipment manufacturer's requirements and the combustion air supply requirements of applicable codes and standards.
7. Use the unit only in the manner intended by the manufacturer. If you have questions, contact the manufacturer.
8. This unit is intended for general ventilating only. Do not use to exhaust hazardous or explosive materials and vapors. Do not connect this unit to range hoods, fume hoods or collection systems for toxics.
9. When cutting or drilling into wall or ceiling, do not damage electrical wiring and other hidden utilities.
10. If installed indoors this unit must be properly ducted to the outdoors.

**SOUND ATTENUATION**

Take these simple steps to attenuate noise from the unit.

**OUTSIDE THE BUILDING**

Exhaust velocity noise is the primary cause of unit-related noise outside the building. Size the exhaust duct and grille for less than 1000 FPM air velocity. When practical, orient the exhaust air hood to point away from houses or public areas.

**DUCTS**

Make sure the ductwork at the unit outlets is stiff enough to resist the flexure and resulting booming associated with system start-up and shut-off.

In general, provide smooth transitions from the ERV's outlets to the duct. The ducts connecting to the outlets should be straight for a sufficient distance, with gradual transitions to the final duct size.

These guidelines are consistent with SMACNA recommended duct layout practices for efficient and quiet air movement. Follow SMACNA guidelines.

**RADIATED NOISE**

The HE1.5XIN is insulated with high-density fiberglass. This provides significant attenuation of radiated sound.

The inlet ducts can be significant sources of radiated sound as well. The OA and RA ducts (inlet ducts) should be insulated for sound control. This insulation should start at the unit. At a minimum the first ten feet of duct should be insulated. All parts of the OA and RA ducts located in the mechanical space should be insulated for sound control, both to minimize sound radiation out of these ducts and also to control sound radiation into the ducts.

**CAUTION**

To avoid motor bearing damage and noisy and/or unbalanced blowers, keep drywall spray, construction dust, etc., out of unit.



## INSTALLATION

## FIELD CONVERSION OF OPENINGS

The HE1.5XIN is designed to allow field conversion of the unit openings. This means the motorized impeller subassemblies can be moved to an adjacent wall of the unit if that opening is preferred. The outlet openings can also be moved to an adjacent wall. Before you start, plan the duct work layout. Determine which openings are to be converted.

## TO FIELD CONVERT INLET OPENING

1. Disconnect motor harness connector (A) by the motor. Move the wire harness out of the way if necessary.
2. Support the impeller subassembly. Remove the eight ¼-20 bolts (B) retaining the impeller subassembly plate to the side rails and front and back tabs.
3. Lift the entire impeller subassembly (C) out of the unit and set aside. Leave the rails in the unit.
4. Remove the patch pan (D) from the desired opening.
5. Using the exposed sheet metal cutout, cut the insulation from the desired opening.
6. Seal the edges of the cut insulation to prevent erosion of the insulation edges and having debris in the air stream.
7. Install the patch pan over the undesired opening.
8. Install the insulation in the undesired opening. Seal the insulation.
9. Remove the duct flange from the undesired opening and install it at the desired opening.
10. If both inlet openings are to be converted, repeat Steps 2 – 9 for the second inlet opening.
11. At this point, if there are outlet openings for conversion, you will want to address them before proceeding with the inlet opening.
12. After converting the outlet openings move the unit floor brackets (E), if necessary, so when the unit is re-oriented the floor brackets support the unit on the floor.
13. Rotate the unit to the desired orientation, if necessary.
14. Install the impeller subassembly into the new inlet opening and fasten with eight ¼-20 bolts to retain to the side rails and front and back tabs. Make sure the motor harness connector is towards the front of the unit.
15. Connect the motor harness.
16. Repeat Steps 14 – 15 for other impeller subassembly if required.
17. Tidy up any wire harnesses that were moved making sure motor wires are taut and away from the impeller blades.

- Turn off the disconnect switch on the unit.  
**Make sure electrical power is shut off to the unit and disconnect switch.**
- Remove the access doors from the unit.
- Remove the core strap, filters, and energy exchanger cores from the unit.

## FIELD CONVERSION

## TO FIELD CONVERT OUTLET OPENING

1. Remove the patch pan (F) from the desired opening.
2. Using the exposed sheet metal cutout, cut the insulation from the desired opening.
3. Seal the edges of the cut insulation to prevent erosion of the insulation edges and having debris in the air stream.
4. Install the patch pan over the undesired opening.
5. Install the insulation in the undesired opening. Seal the insulation.
6. Remove the duct flange (G) from the undesired opening and install it at the desired opening.
7. If both outlet openings are to be converted, repeat Steps 1 – 6 for the second outlet opening.
8. If Inlet Openings are being converted return to Step 12 in the “To Field Convert Inlet Opening” instructions.

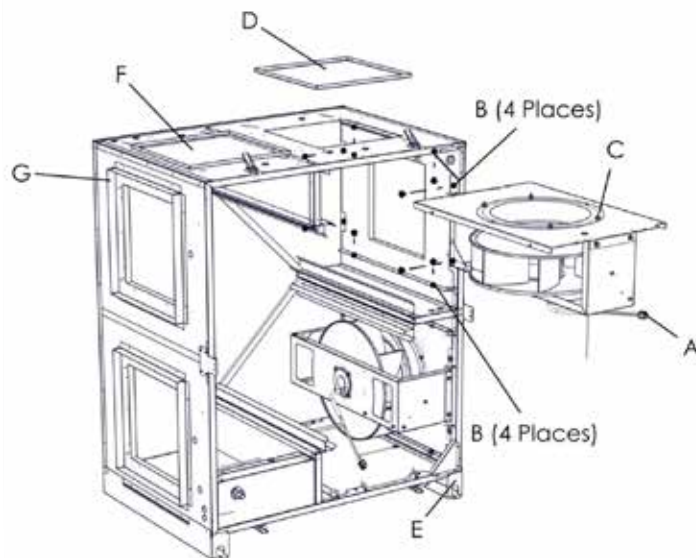

After completion of the field conversion,

- Clean out the interior of the unit to remove any debris.
- Install energy exchanger cores, filters, and core strap.
- Install access doors on the unit

## INSTALLATION

### INSTALLATION INSTRUCTIONS

#### ACCESSORIES

These ERVs may be ordered with factory-installed features including Isolation Dampers and Electronically Commutated Motors. Consult the supplemental Installation and Operation Manual(s) for these features if supplied.

#### WARNING

Standard HE1.5XIN with single phase original equipment motors are NOT suitable for use with solid state speed control.

Three phase motors are NOT suitable for use with solid state speed control. If speed control is desired use the VFD option.

Single phase ECM motors are NOT suitable for use with solid state speed control. They already have speed control built into the motor electronics.

Le HE1.5XIN avec moteurs d'équipement d'origine monophasés ne convient pas pour une utilisation avec regulateur de vitesse électronique.

Moteurs de trois phase ne convient pas pour utilisation avec regulateur de vitesse électronique. Si la régulation de vitesse est souhaité, utiliser l'option VDF.

Moteurs d'une phase de l'ECM ne conviennent pas pour une utilisation avec regulateur de vitesse électronique. Ils ont déjà le contrôle de vitesse intégré dans le moteur électronique.

#### CAUTION

The HE1.5X weighs 340 lbs. It is the installer's responsibility to make sure that the screws or bolts used for securing the units are properly selected for the loads and substrates involved.

Secure the HE1.5X with straps or clamps so that it cannot fall or tip in the event of accident, structural failure or earthquake.

#### MOUNTING THE UNIT

The HE1.5X is manufactured with two floor stands for installation at floor level in an upright position. Adequate clearance for the access door latches must be provided.

The HE1.5X may also be hung on the wall or suspended from a ceiling. Screw or bolt mounting straps or brackets directly to the sheet metal case as necessary. Remove the access doors before installing screws — make sure your fasteners don't damage internal parts. Do not screw into the access doors.

#### ELECTRICAL SPECIFICATIONS

Use conduit, strain reliefs, etc. as required by code to secure the field wiring. Electrical knockouts are provided for alternate line voltage and voltage control locations for field wiring to the internal electrical box. If the alternate sites are desired for field wiring then carefully remove the knockout plugs from the alternate sites. Insulate and plug the open knockout locations.

**NOTE:** If your unit is equipped with EC Motors, please refer to "EC Motor Manual Supplement for RenewAire Light Commercial Units" for more detail.

### HE1.5XIN P1 SINGLE PHASE UNIT - STANDARD WIRING SCHEMATICS

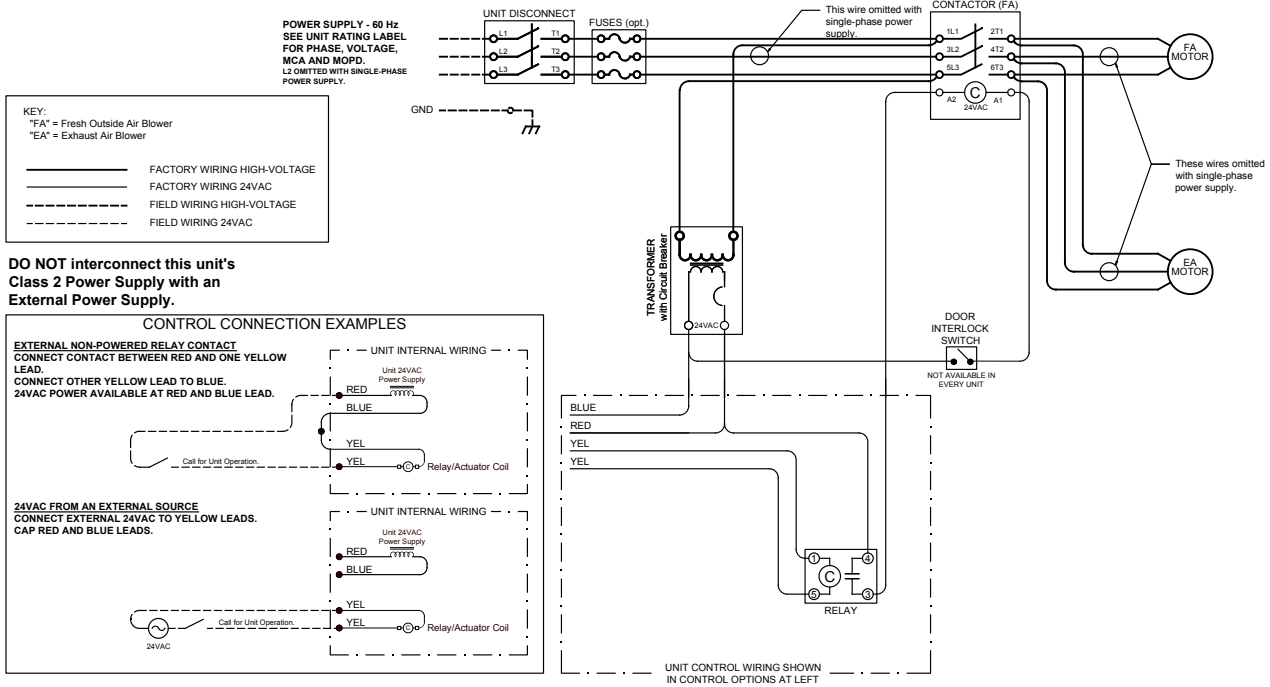

### HE1.5XIN P3 THREE PHASE UNIT - STANDARD

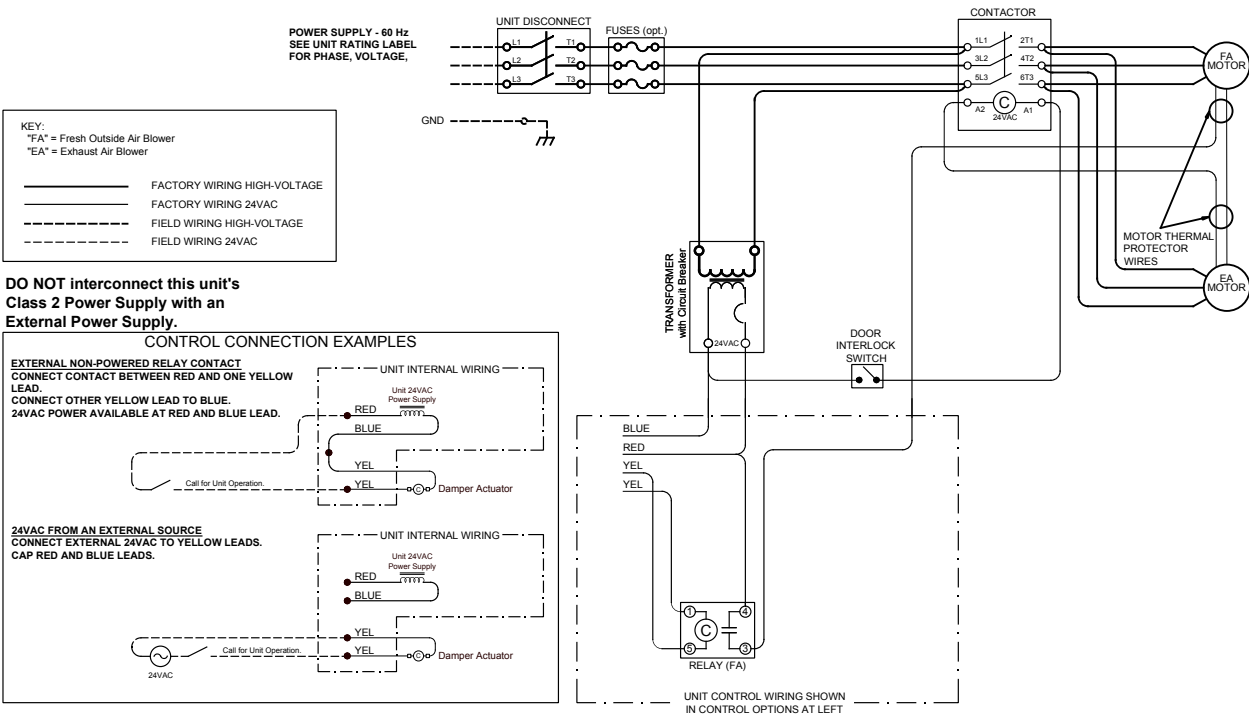

INSTALLATION

WIRING SCHEMATICS HE1.5XIN P1 IBC SINGLE PHASE UNIT WITH INDEPENDENT BLOWER CONTROL

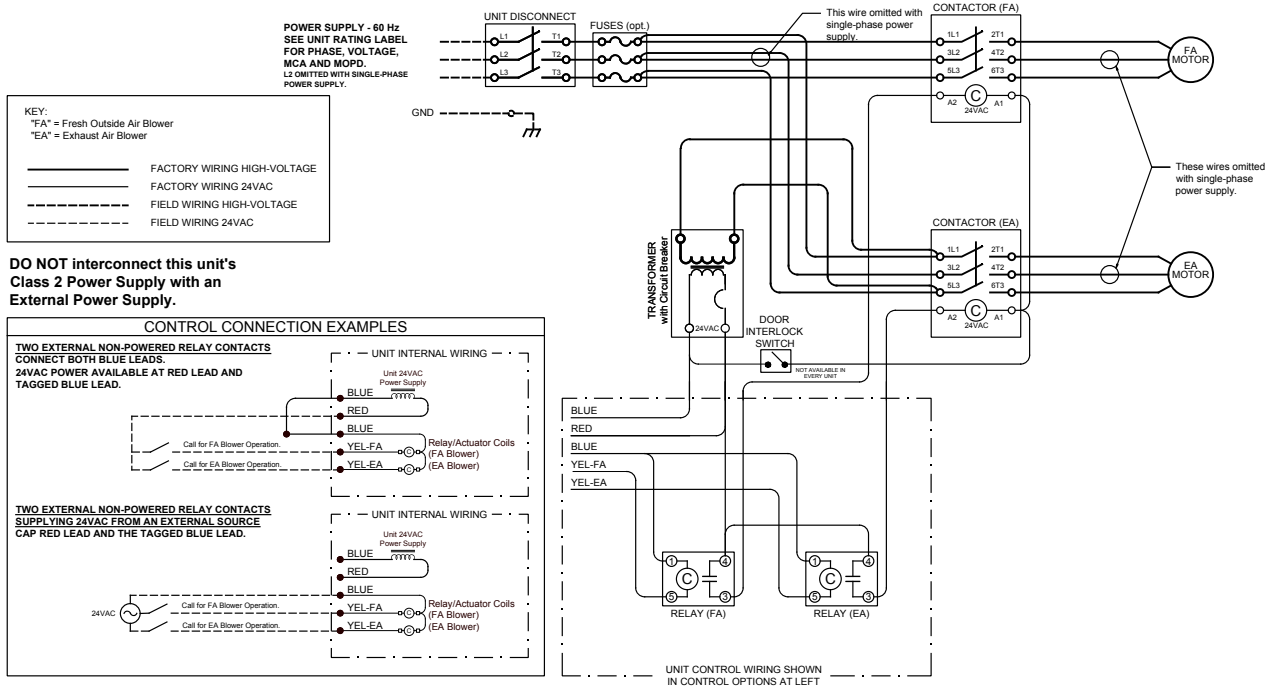

HE1.5XIN P3 IBC THREE PHASE UNIT WITH INDEPENDENT BLOWER CONTROL

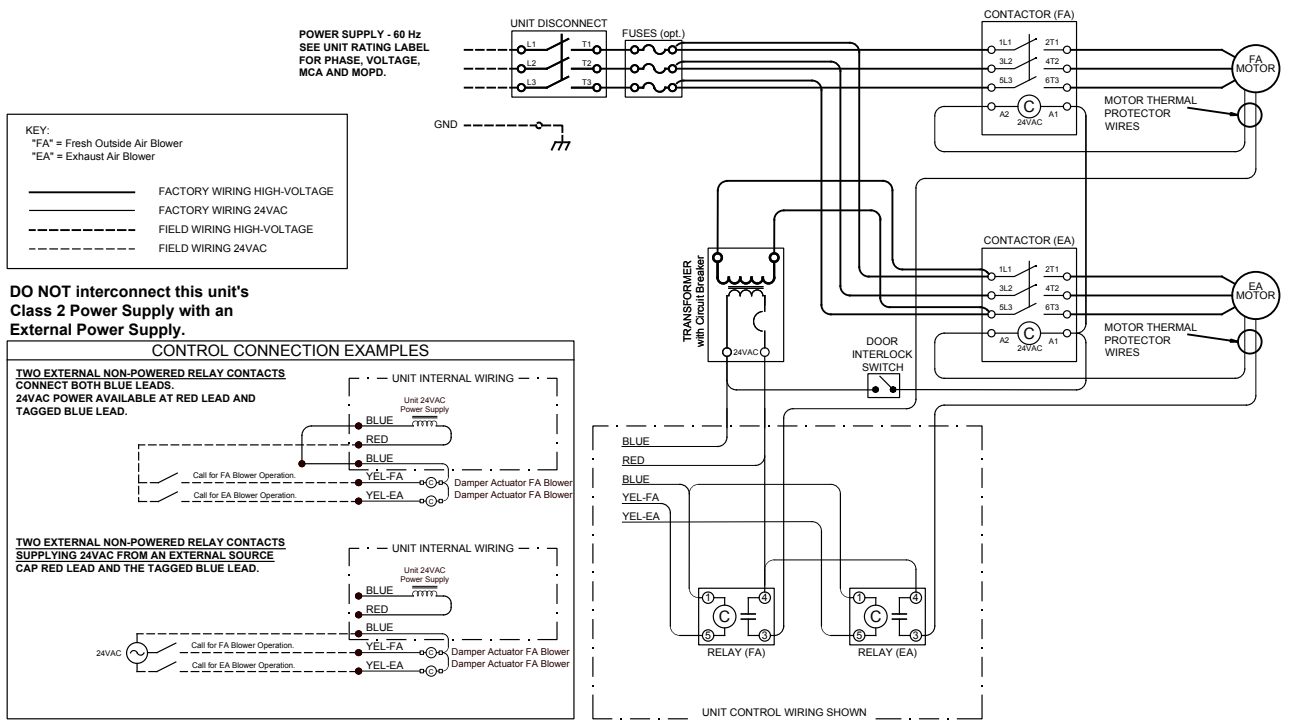

**INSTALLATION**

**LOW VOLTAGE CONTROL SYSTEM**

This ERV is provided with a Class II 24VAC power supply system that operates the unit’s contactor(s) for HE1.5X. The ERV’s 24VAC Power Supply can also be used to power the externally-installed controls system: up to 8VA of power is available.

The unit’s power supply system includes isolation relay(s) so you can use external controls whose contact ratings are as low as 50mA (1.2VA). Also, it is possible to operate the isolation relays with 24VAC power from an external source (with proper wiring connections).

A built-in circuit-breaker prevents damage to the transformer and other low-voltage components in the event of a short-circuit or overload. In extreme cases, the transformer itself is designed to fail safely.

**SPECIFICATIONS**

- Nominal Output Voltage under load: 24VAC
- Typical Output Voltage at no load: 29-31V
- Minimum contact rating for connected control device: (50mA (1.2VA)
- Circuit Breaker Trip Point: 3A

**INSTALLATION INSTRUCTION**

**CAUTION**

1. Connect only to components intended for use with 24VAC power.
2. Do not undersize the low-voltage wires connected to this device. Observe the wire length and gauge limits indicated in this manual.
3. Do not overload this unit’s 24VAC power supply system. Confirm that the power requirements of devices you connect to this power supply system do not exceed 8VA in total.
4. If an external source of 24VAC power is used to control the unit, consult the wiring schematics and connect the external power only to the specified terminals in order to avoid damaging the unit or external controls. Connect only CLASS II power to the control terminals of this unit.
5. Unit is not equipped to receive analog signals (such as 1-10vdc or 4-20mA).
6. Unit is not equipped to communicate directly with Building Management Systems (such as BACNET, LONWORKS, etc.). However, the unit can be controlled by powered or non-powered contacts operated by any kind of control system.

**CAUTION**

If primary-side voltage is 230VAC, move black primary-side lead from transformer’s “208V” terminal to the transformer’s terminal marked “240V” (“230V” in some units). Do not move the black primary-side lead that is connected to the transformer’s “COM” terminal.

**HOW TO RESET THE 24VAC CIRCUIT BREAKER**

If the transformer is subjected to an excessive load or a short circuit, the circuit breaker will trip to prevent the failure of the transformer. When it trips the circuit breaker’s button pops up. Shut off the primary-side power to the unit, and remove the excessive load or the short. The circuit breaker can be reset about fifteen seconds after it trips by pressing in the button.

**LIMITS OF POWER OUTPUT**

If limits on wire gauge and length are observed, you may connect control devices that draw up to 8VA to the blue and red wires. More than one device can be connected as long as total steady-state load does not exceed 8VA.

<b>OBSERVE THESE LIMITS TO WIRE LENGTH AND GAUGE</b> in order to ensure reliable operation of the control system.						
Wire Gauge	#22	#20	#18	#16	#14	#12
Circuit Length	100'	150'	250'	400'	700'	1000'
"Circuit Length" is distance from ERV to Control Device.						

**INSTALLATION**

**CONTROL WIRING SCHEMATICS**

**NOTE:** The simplified schematics below show only the relevant portions of the low-voltage control circuit in the ERV unit and representational external control approaches. See the complete unit schematics elsewhere in this manual.

**CAUTION**

Be careful if the external control system provides 24VAC power at its control output: make sure blue and red leads are separately capped and not connected to any other wires.

**CONTROL WIRING EXAMPLES BY TYPE OF APPLICATION**

**A. Single 2-wire Control:** Use this schematic if the control requires no power to operate and acts like a simple on/off switch. The control must not supply any power to the ERV unit. Connect the blue lead to one yellow lead. Connect the control's contacts to the red lead and the remaining yellow lead.

Control on separate Power Supply, no power present at Control Output:  
Wire as shown for the Single 2-wire control.

**CAUTION**

Make sure the control provides no voltage or current at its output terminals.

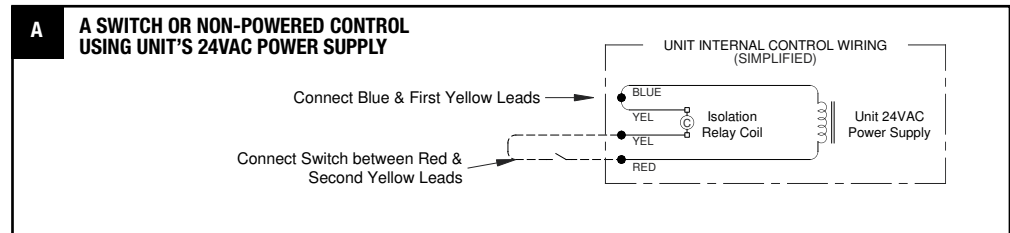

**B. Control Sending 24VAC "On" Signal (from an external power source) to ERV:** Make sure the blue and red leads are separately capped and not connected to any other wires. Now you safely can apply 24VAC to the two yellow leads to operate the ERV's isolation relay.

**CAUTION**

Supply only 24VAC (not VDC) from a Class II Power Source.

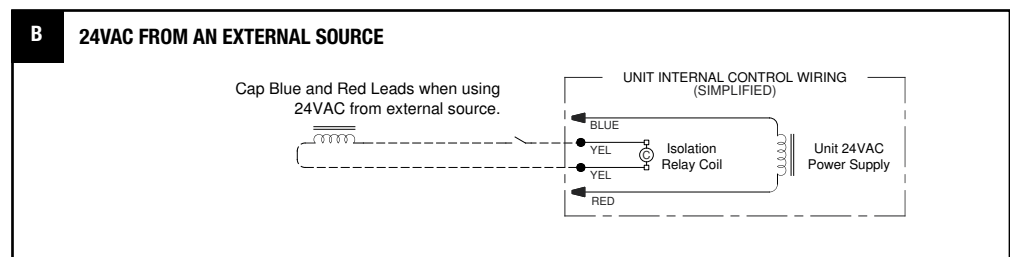

**C. Control operating on Unit's 24VAC Power Supply:** 24VAC power is available at the blue and red leads. Connect one of the yellow leads to the blue lead. Connect the switched output of the Control to the red lead to operate the ERV's isolation relay.

**CAUTION**

External control system should not draw more than 8VA.

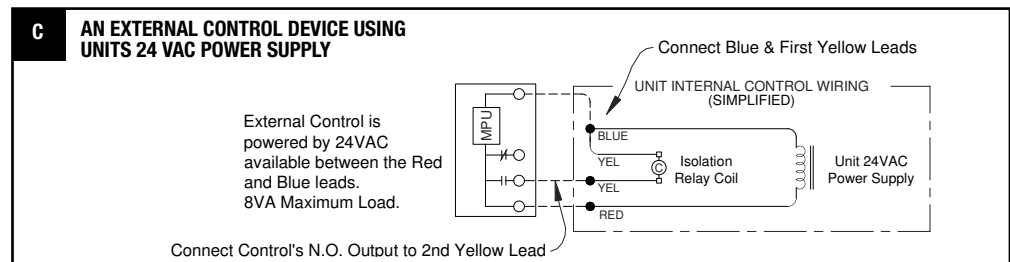

## INSTALLATION

- D. Control System with 2 Non-powered Relay Contacts:** ERVs with Independent Blower Control Only: Use this schematic if the external control system provides no voltage or current at its output contacts. Connect the two blue leads together. Connect the red lead to one side of each of the output contacts. Connect the other side of the output contacts to the appropriate yellow leads (marked “FA Blower” and “EA Blower”).

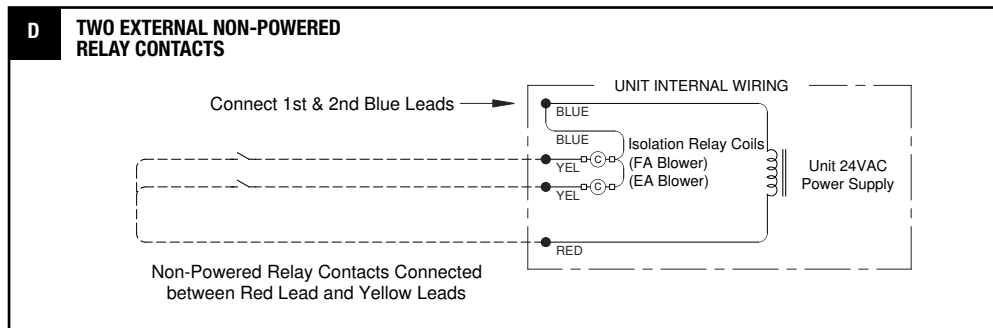

- E. Control System Sending two 24VAC “On” Signals (from an external power source):** ERVs with Independent Blower Control Only: Make sure the blue and red leads are separately capped and not connected to any other wires. Now you safely can apply one of the 24VAC signals to the one of the yellow leads (marked “FA Blower” and “EA Blower”) and the blue lead to operate one of the ERV’s isolation relay. Supply the second 24VAC signal to the other yellow lead and again to the blue lead (make sure the polarity of each wire connected to the blue lead is the same).

**CAUTION**

Supply only 24VAC (not VDC) from a Class II Power Source.

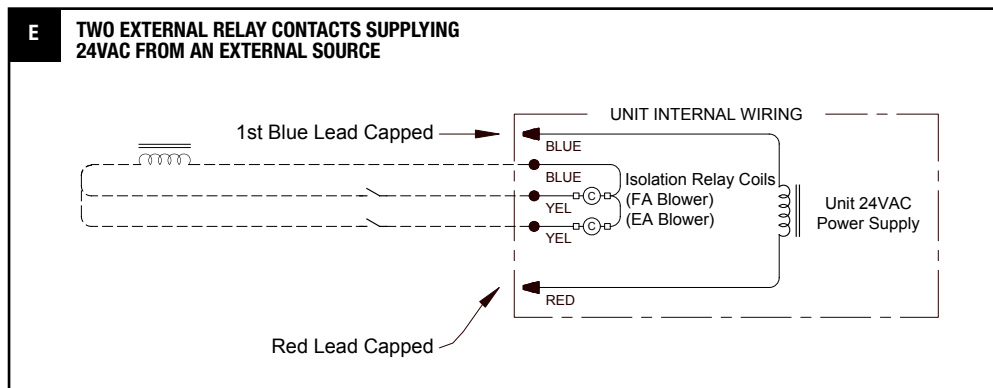

- F. Control System Operating Isolation Dampers with End Switches:** Use Isolation Dampers with electrically separate end switches. The end switches are used to separately control the ERV unit’s Isolation Relays. Also, specify the ERV with Independent Blower Control. This ensures that each damper is open before the respective blower starts up.

**NOTE:** Because the ERV’s contactors will only be operating once the Dampers are open, the power draw of the Damper Actuators is allowed to be as much as 35VA while opening (including power draw of the external control system, if any). However the power draw of the fully-opened (stalled) Actuators (and external control system if any) must be less than 8VA.

**START-UP**

**MEASURING AIR FLOW**

**EQUIPMENT REQUIRED**

- A magnehelic gauge or other device capable of measuring 0 to 1.5 in. water of differential pressure.
- 2 pieces of natural rubber latex tubing, 1/8" ID, 1/16" Wall works the best.

**NOTE:** Be sure to remove cap from pressure port before inserting tubing. Insure tubing is well seated in pressure ports.

**NOTE:** The tubing should extend in the pressure port approx. 1 inch.

**CROSS CORE STATIC PRESSURE MEASUREMENT INSTRUCTIONS**

The individual differential static pressures (DSP) can be measured using the installed pressure ports located in the front of the units core access doors.

**NOTE:** These ports have been carefully located on the unit as to give you the most accurate airflow measurement. Do not relocate pressure ports.

- To read SCFM of Room Air (RA) install the "high" pressure side (+) of your measuring device to the Room Air (RA) port and the "low" pressure side (-) to the Exhaust Air (EA) port.

- To read SCFM of Room Air (RA) install the "high" pressure side (+) of your measuring device to the Room Air (RA) port and the "low" pressure side (-) to the Exhaust Air (EA) port.

- Use the reading displayed on your measurement device to cross reference the CFM output using the conversion chart.

**NOTE:** Be sure to replace cap into pressure port when air flow measuring is completed.

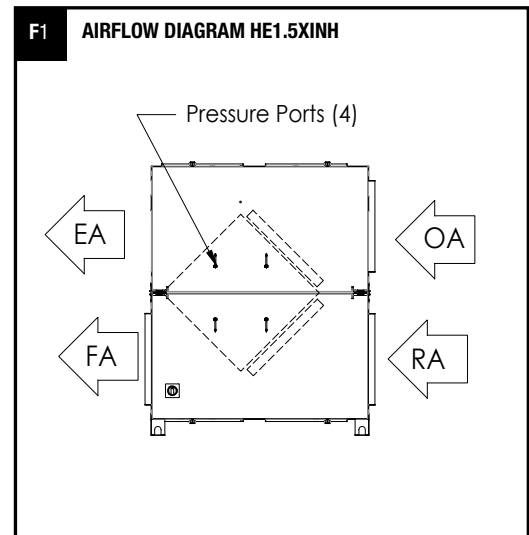
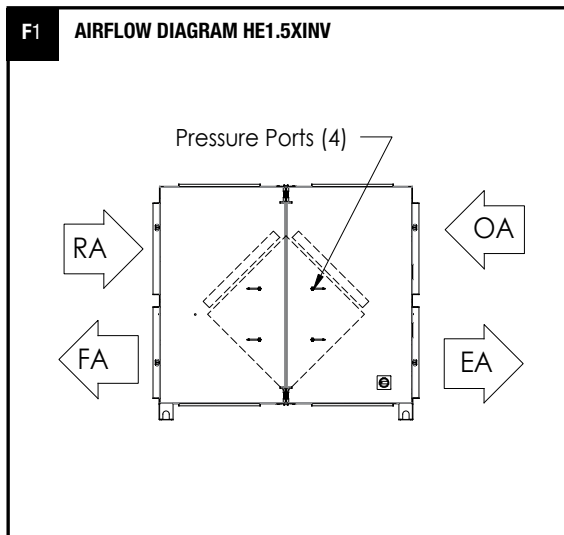

DIFFERENTIAL STATIC ACROSS CORE DSP VS. CFM													
HE1.5XIN		DSP	0.15	0.20	0.25	0.30	0.35	0.40	0.45	0.5	0.55	0.60	0.65
	Fresh Air (FA)	CFM	380	500	620	740	860	980	1095	1215	1330	1450	1565
	Room Air (RA)	CFM	320	440	565	695	825	960	1095	1235	1375	1515	-

NOTE: Pressure drop of clean 2" MERV-8 Filters is included in the Unit Performance Ratings Table.



START-UP

**FILTER SPECIFICATIONS**

- (2) 14" x 20" x 2" and (2) 16" x 20" x 2" (nominal) pleated filters. Actual size: 13.5" x 19.5" x 1.75" and 15.5" x 19.5" x 1.75".
- Optionally (4) 15" x 20" x 2" (nominal) pleated filters can be used. Actual size: 14.5" x 19.5" x 1.75"
- Unit shipped with MERV-8 Filters. Minimum recommended effectiveness: MERV-6

**MEASURING AIR FLOW**

**INITIAL PRESSURE DROP OF MERV 8 FILTERS SUPPLIED WITH THIS UNIT**

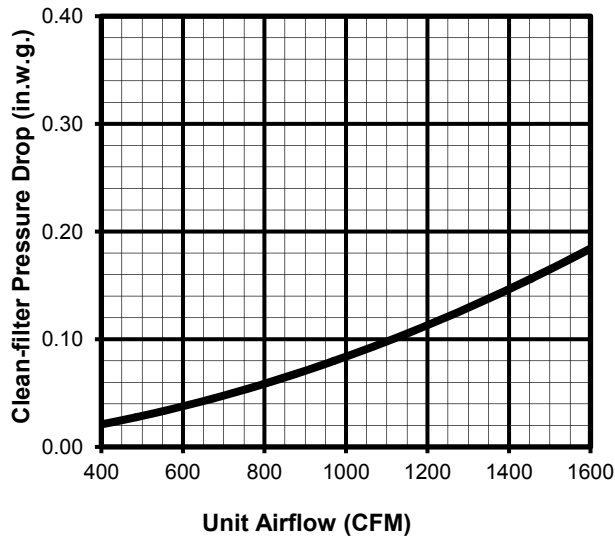

NOTE: clean filter pressure drop is included in unit airflow performance tables.

**INITIAL PRESSURE DROP OF MERV13 FILTERS AVAILABLE AS AN OPTION.**

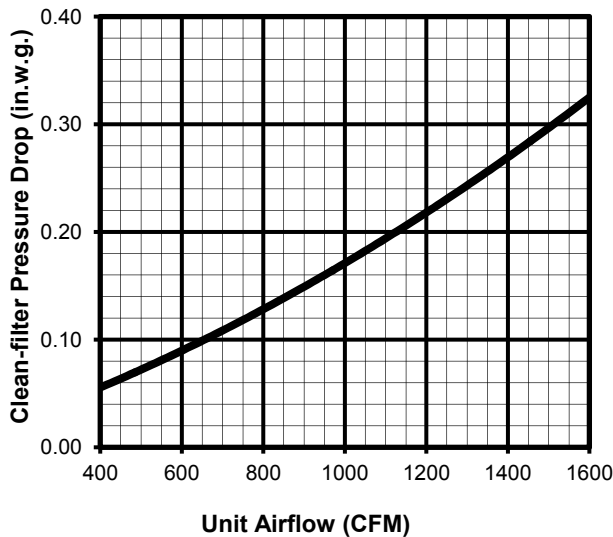

NOTE: pressure drop of standard filter is included in unit airflow performance tables.

MAINTENANCE

SERVICE PARTS HE1.5XIN(H & V) Horizontal and Vertical Units

HE1.5XINH SHOWN

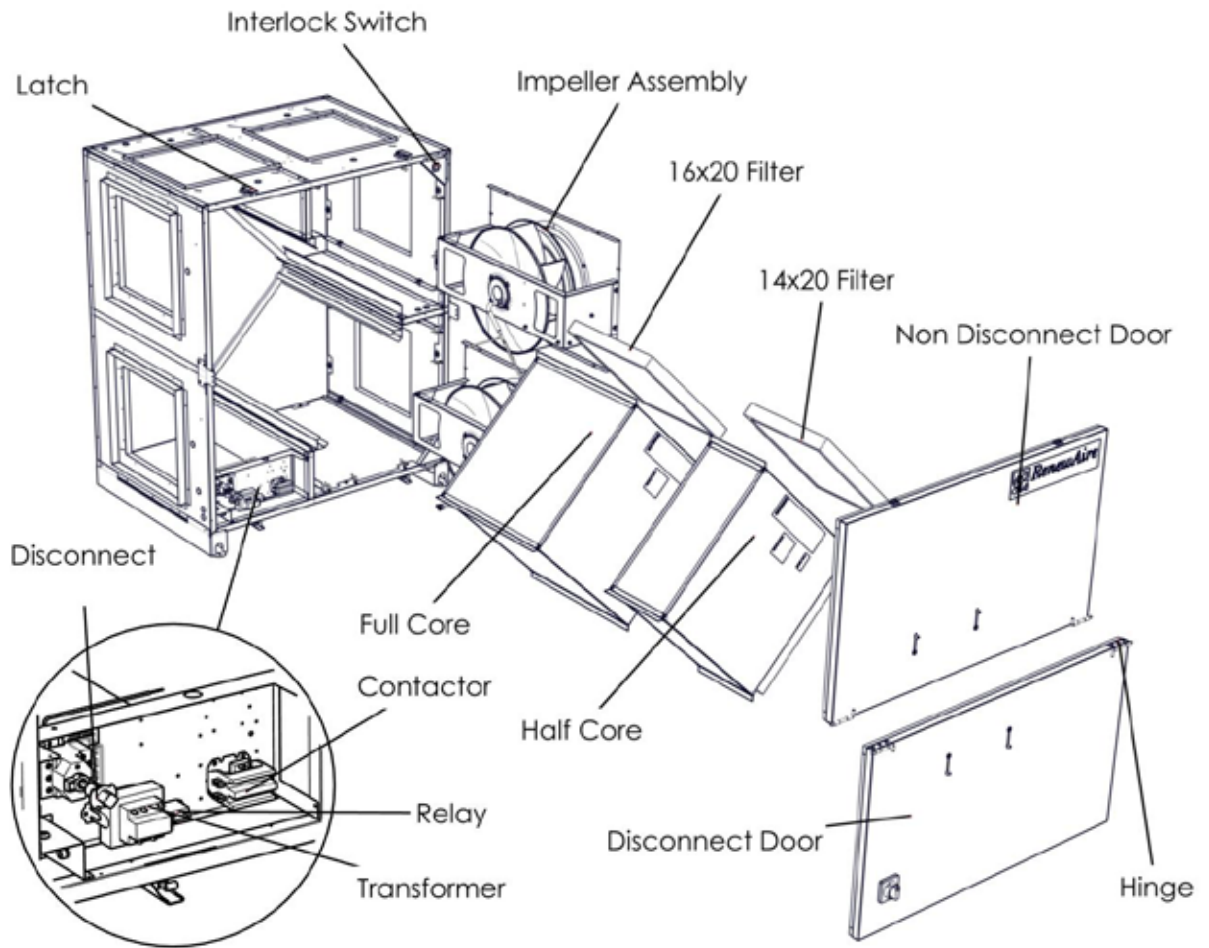

## MAINTENANCE

## REQUIREMENTS

**⚠ WARNING**

Danger of Electrical Shock when servicing an installed unit.

**ALWAYS DISCONNECT POWER SOURCE BEFORE SERVICING!** More than one disconnect switch may be required. Proper Wiring Size Selection and Wiring Installation are the Responsibility of the Electrical Contractor.

Keep your ERV performing at its best by cleaning it as described below:

**TO CLEAN THE ENERGY EXCHANGE ELEMENT**

Vacuum the face of the energy exchange element yearly. Dust collects only on the entering face of the energy exchange element, right where the filter sits. The interior of the energy exchange element stays clean even if the element faces are dust covered.

1. Remove the filters (see below)
2. Vacuum the exposed faces of the energy exchange element with a soft brush attachment
3. Vacuum out dust from the rest of the unit case
4. Install new filters

**INSPECT AND CHANGE THE FILTERS REGULARLY.**

Inspect and/or replace filters every two or three months when the HE1.5X is in regular use, or as needed. Filters must be used or the energy exchange core will become blocked by dust and the unit will not do its job. In extreme cases components may be damaged.

1. To access the filters unlatch the access doors. The access doors may be removed.
2. Pull the dirty filters out and replace with new filters.

**NOTE:** The filters supplied in the unit are usually able to keep the energy exchange core clear for several months. Finer filters can be used but must be cleaned more often. If using finer filters, their increased resistance to flow must be allowed for in the system design.

**MOTOR MAINTENANCE**

The motor needs no lubrication. If necessary vacuum clean the blower wheels at the same time you clean the face of the energy exchange element (annually).

**CAUTION****DO NOT WASH THE ENERGY EXCHANGE CORE.**

Keep it away from water or fire to avoid damaging it. Always handle the core carefully.

**⚠ WARNING**

Don't allow the access door to drop when unlatched. Injury to personnel or damage to unit may occur.

Keep fingers away from between the access doors when unlatching and opening the doors. Potential PINCH POINT.

**⚠ WARNING****RISK OF INJURY OR DAMAGE.**

Motor has an automatic reset thermal protector. Disconnect power before servicing or resetting motor thermal protector. Use caution, motor may be hot. The motor must cool before it resets the thermal protector.

If the motor thermal protector tripped, correct the issue that caused the motor to overheat (e.g. over motor rated amperage or locked rotor).



#### **UNMATCHED VENTILATION SUPPORT**

As much as our unsurpassed quality and performance, our customers can also depend on our professional support staff for swift, professional assistance with all their technical, application, and service needs. **Every time. Anywhere.**

At RenewAire — unlike other ventilation suppliers — advanced ventilation solutions are all we do. Our sole passion. Which is why for all commercial projects, we are the “V” in HVAC... and the only name you need to know.

#### **USA**

(800) 627-4499  
FAX: (608) 221-2824  
4510 HELGESEN DRIVE  
MADISON, WISCONSIN 53718 USA  
WWW.RENEWAIRE.COM

#### **CANADA**

(905) 475-8989  
FAX: (905) 475-5231  
WWW.MITSUBISHIELECTRIC.CA

#### **MEXICO, CENTRAL & SOUTH AMERICA**

52 (222) 2 233 911  
FAX: 52 (222) 2 233 914  
WWW.SOLER-PALAU.MX