

Sample	VP-S	30NB-90	5K	T5R	UNV	PCR-TL	SF2	GENIXX	BLC	RA	BBT
Ordering											
	<b>A</b>	<b>B</b>	<b>C</b>	<b>D</b>	<b>E</b>	<b>F</b>	<b>G</b>	<b>H</b>	<b>I</b>	<b>J</b>	<b>K</b>

**DETAILS**

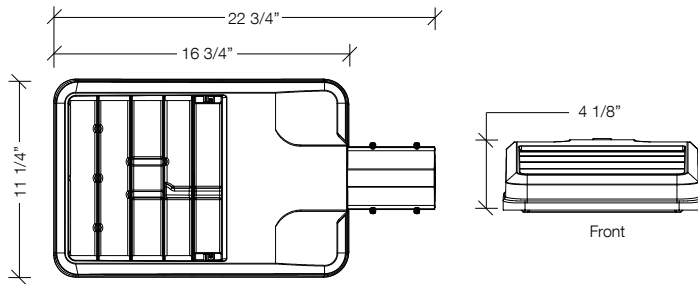

**MOUNTING OPTIONS**

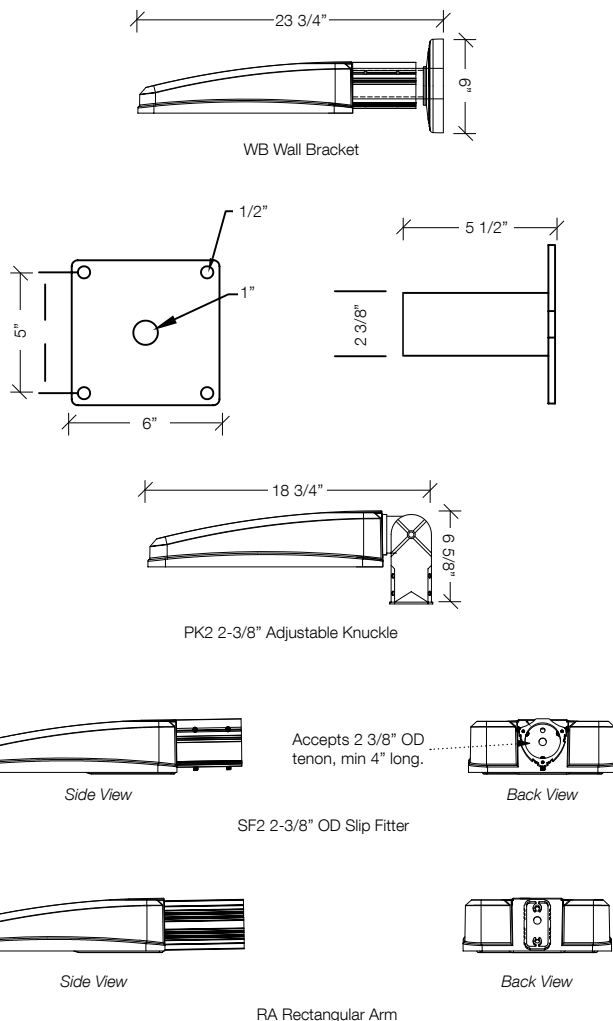

**A. MODEL**

**VP-S** Viper - Small

**B. ENGINE-WATTS**

- 22NB-50** 50 Watts - LED Array
- 22NB-70** 70 Watts - LED Array
- 30NB-70** 70 Watts - LED Array
- 30NB-90** 90 Watts - LED Array

**C. CCT - COLOR TEMP**

- 5K** 5000K (std.)
- 4K** 4000K
- 3K** 3000K

**D. OPTICS<sup>6</sup>**

- T1** type I
- T2** type II
- T3** type III
- T4** type IV
- T5R** type V, rectangular
- T5QM** type V, square medium
- T5W** type V, round wide
- FR** front row auto optic

**E. VOLTAGE**

- UNV** 120-277V
- 347V** 347V
- 480V** 480V

**F. ELECTRICAL OPTIONS**

- PCR-TL** photocell, twist-lock
- PCR-SC** photocell, shorting cap
- 2PF** dual power feed <sup>1,2</sup>

**G. SENSOR OPTIONS**

- OCS** occupancy sensor (on/off)
- MDD** motion dimming detector

**H. CONTROL OPTIONS**

- GENI-XX** Energeni<sup>5</sup>

**I. HOUSE SIDE SHIELD OPTIONS**

- HSS-90** house side shield 90°
- HSS-180** house side shield 180°
- BLC** backlight control<sup>4</sup>

**J. MOUNTING OPTIONS**

- RA** rectangular arm
- SF2** 2 3/8" OD slip-fitter
- PK2** 2 3/8" adjustable knuckle
- WB** wall bracket

**K. COLOR**

- BBT** basic black textured
- BMT** black matte textured
- WHT** white textured
- MBT** metallic bronze textured
- BZT** bronze textured
- DBT** dark bronze textured
- GYS** gray smooth
- DPS** dark platinum smooth
- GNT** green textured
- MST** metallic silver textured
- MTT** metallic titanium textured
- OWI** old world iron
- RAL** \_\_\_\_\_

**CERTIFICATIONS/LISTINGS**



**Certification Data:** UL/cUL Wet Location Listed, LM79/LM80 Compliant, IDA Approved, 3G Vibration Rated, DesignLights Consortium<sup>®</sup> Qualified<sup>3</sup>

<sup>1</sup> not available with 64NB-135  
<sup>2</sup> not available @ 347V or 480V input  
<sup>3</sup> DesignLights Consortium Qualified. Refer to www.designlights.org Qualified Products List under Family Models for details.  
<sup>4</sup> T4 optic only  
<sup>5</sup> When ordering Energeni, specify the routine setting code (example GENI-04). See Energeni brochure and instructions for setting table and options. Not available with sensor options.  
<sup>6</sup> To rotate optics Left or right 90 degrees, specify L or R after the optical distribution example T4L.

**VIPER - SMALL (LED)**

Small Viper Luminaire

**Max Weight:** 15.0 lbs

**Max EPA:** 0.67 sq ft

**General:** The Beacon Viper luminaire is available in two sizes with a wide choice of different LED Wattage configurations and optical distributions designed to replace HID lighting up to 1000W MH or HPS and with 5 different mounting options for application in a wide variety of new and existing installations. Luminaires are suitable for wet locations.

**Bezel Optic System:** Each Viper luminaire is supplied with an one piece optical cartridge system consisting of an LED engine, LED lamps, optics, gasket and stainless steel bezel. The cartridge is held together with internal brass standoffs soldered to the board so that it can be field replaced as a one piece optical system. Two-piece silicone and micro-cellular polyurethane foam gasket ensures a weather-proof seal around each individual LED.

The optical cartridge is secured to the die cast housing with fasteners. The optics are held in place without the use of adhesives. The cartridge assembly is available in various lighting distributions using TIR designed acrylic optical lenses over each LED.

**Lifesield™ Circuit:** Thermal circuit shall protect the luminaire from excessive temperature by interfacing with the 0-10V dimmable drivers to reduce drive current as necessary. The factory-preset temperature limits shall be designed to ensure maximum hours of operation to assure L70 rated lumen maintenance. The device shall activate at a specific, factory-preset temperature, and progressively reduce power over a finite temperature range.

A luminaire equipped with the device may be reliably operated in any ambient temperature up to 55°C (131°F). The thermal circuit will allow higher maximum Wattages than would be permissible on an unregulated luminaire (if some variation in light output is permissible), without risk of premature LED failure or lumen depreciation. Operation shall be smooth and undetectable to the eye. Thermal circuit shall directly measure the temperature at the LED solder point. Thermal circuit shall consist of surface mounted components mounted on the LED engine (printed circuit board). For maximum simplicity and reliability, the device shall have no dedicated enclosure, circuit board, wiring harness, gaskets, or hardware. Device shall have no moving parts, and shall operate entirely at low voltage. The device shall be located in an area of the luminaire that is protected from the elements. Thermal circuit shall be designed to “fail on”, allowing the luminaire to revert to full power in the event of an interruption of its power supply, or faulty wiring connection to the drivers.

Device shall be able to co-exist with other 0-10V control devices (occupancy sensors, external dimmers, etc.). The device will effectively control the solder point temperature as needed; otherwise it will allow the other control device(s) to function unimpeded.

**Printed Circuit Board (PCB):** Aluminum thermal clad board with 0.062” thick aluminum base layer, thermally conductive dielectric layer, 0.0014” thick copper circuit layer circuit layer designed with copper pours to minimize thermal impedance across dielectric. Board will be mounted to the heat sink using minimum 12 #4-40 screws to ensure contact with thermal pad and heat sink. Use of thermal grease will not be allowed.

**Housing and LED Thermal Management:** The Viper® monolithic housing design creates over 4.5 square feet (small Viper) or 7.7 square feet (large Viper) of heat-sinking surface area. Vertical fins, combined with flow-thru openings prevent sediment and moisture buildup on critical heat sinking surfaces without the need for grates, screens or other debris control tactics. The Viper housing, electrical compartment and fitter are made from die cast aluminum that is pre-treated and powder-coated to meet the most rugged industry standards. The finish is corrosion resistant to meet ASTM-B-117, resists cracking or loss of adhesion per ASTM D522, resists surface impacts of up to 160 inch-pound. All external hardware is corrosion resistant. The housing serves as a heat-sink for the LED bezel with a separate compartment for the drivers.

**Electrical Assembly:** The fixture electrical compartment shall contain all LED driver components and shall be provided with a push-button terminal block for AC power connections. The housing is designed for an optional twist lock photo control receptacle.

**Accessibility:** Although the Viper luminaire is designed to operate for many years without maintenance, accessibility is a key component in its design. The Drivers are mounted on a removable door that is secured with keyslotted screws and hinges down for convenient access. The drivers are field replaceable using quick disconnects.

**Drivers:** Luminaires are equipped with an LED driver that accepts 100V through 277V, 50 Hz to 60 Hz (UNIV), or a driver that accepts 347V or 480V input. Power factor is .92 at full load. All electrical components are rated at 50,000 hours at full load and 25°C ambient conditions per MIL- 217F Notice 2. Dimming drivers are standard, with connections for external dimming equipment available upon request. Component-to-component wiring within the luminaire may carry no more than 80% of rated load and is listed by UL for use at 600VAC at 50°C or higher. Plug disconnects are listed by UL for use at 600 VAC, 13A or higher. 13A rating applies to primary (AC) side only.

**Surge Protector:** The on-board surge protector shall be a UL recognized component for the United States and Canada and have a surge current rating of 20,000 Amps using the industry standard 8/20 pSec wave. The LSP shall have a clamping voltage of 825V and surge rating of 540J. The case shall be a high-temperature, flame resistant plastic enclosure.

**Fasteners:** All fasteners shall be stainless steel. When tamper resistant fasteners are required, spanner HD (snake eye) style shall be provided (special tool required, consult factory).

**Color Rendering Index (CRI):** Luminaire shall have a minimum CRI of 67 at 5000K.

**Operating Environment:** Shall be able to operate normally in ambient temperatures from -40°C to 40°C

**Finish:** Finish shall be a Beacote V polyester powder-coat electro-statically applied and thermocured. Beacote V finish shall consist of a five stage iron phosphate chemical pre-treatment regimen with a polymer primer sealer, oven dry off, and top coated with a thermoset super TGIC polyester powder coat finish. The finish shall meet the AAMA 605.2 performance specification which includes passing a 3000 hour salt spray test for corrosion resistance and resists cracking or loss of adhesion per ASTM D522 and resists surface impacts of up to 160 inch-pound.

**Agency Certification:** The luminaire shall bear a CSA label and be marked suitable for wet locations. The Beacon Viper is approved by the International Dark-Sky association as a dark sky friendly fixture.

**Warranty:** Beacon luminaires feature a 5 year limited warranty. Beacon LED luminaires with LED arrays feature a 5 year limited warranty covering the LED arrays. LED drivers are covered by a 5 year limited warranty. PIR sensors carry a 5 year limited warranty from the sensor manufacturer. See Warranty Information on www.beaconproducts.com complete details and exclusions.

**Power/Lumens & Distributions**

Engine	Wattage	Delivered Lumens (varies by optic)	Delivered LPW	TM21 Calculated % Lumen Maint. at 100,000 hrs
22NB	50	4700-5020	93-103	96.19%
22NB	70	5780-6200	82-103	85.79%
30NB	70	6408-6850	91-103	95.02%
30NB	90	7700-8260	85-97	85.79%

TM21 is the framework for taking LM-80 data and making useful LED lifetime projections. Reported and Calculated Lifetimes shown are based on hours at the time of this printing. For current Reported and Calculated hours please contact factory or Beacon's web-site.

CCT (COLOR TEMP) Lumen Output Multipliers	CRI (Color Rendering)
<b>5000K</b> = 1.0	min 67 CRI
<b>4000K</b> = .92	min 70 CRI
<b>3000K</b> = .75	min 80 CRI

**DRILL PATTERN**

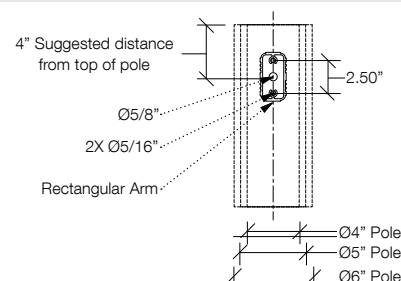

Due to our continued efforts to improve our products, product specifications are subject to change without notice.