

**SHOP DRAWING REVIEW FOR
17 BISHOP STREET, PORTLAND #1733**

**AH-1
SECTION 23 00 00**

- REVIEWED** FURNISH AS CORRECTED
 REVISE AND RESUBMIT REJECTED

Corrections or comments made on the shop drawings during this review do not relieve the Contractor from compliance with requirements of the drawings and specifications. This check is only for review of general conformance with the design concept of the project and general compliance with the information given in the contract documents. The Contractor is responsible for confirming and correlating all quantities and dimensions, selecting fabrication processes and techniques of construction, coordinating his work with that of all other trades and performing his work in a safe and satisfactory manner.

MECHANICAL SYSTEMS ENGINEERS

DATE: March 6, 2018

BY: R. Michael



Submittal

Prepared For:
All Bidders

Date: March 6, 2018

Customer P.O. Number:
Customer Project Number:

Sold To:

Job Number:
Job Name:
HVAC Services - Rob - Bishop Street

Trane U.S. Inc. dba Trane is pleased to provide the enclosed submittal for your review and approval.

Product Summary

Qty	Product
1	3 Ton R410A PKGD Unitary Gas/Electric Rooftop

Daniel Broderick
Trane
860 Spring Street, Unit 1
Westbrook, ME 04092
Phone: (207) 828-1777
Cell:
Fax: (207) 828-1511

The attached information describes the equipment we propose to furnish for this project, and is submitted for your approval.

Product performance and submittal data is valid for a period of 6 months from the date of submittal generation. If six months or more has elapsed between submittal generation and equipment release, the product performance and submittal data will need to be verified. It is the customer's responsibility to obtain such verification.

Table Of Contents

Product Summary	1
3-10 Ton R410A PKGD Unitary Gas/Electric Rooftop (Item A1)	
Tag Data	3
Product Data	3
Mechanical Specifications	4
Unit Dimensions	7
Weight, Clearance & Rigging Diagram.....	11
Accessory	13

Tag Data - 3-10 Ton R410A PKGD Unitary Gas/Electric Rooftop (Qty: 1)

Item	Tag(s)	Qty	Description	Model Number
A1	No Tag	1	3 Ton R410A PKGD G/E High	YHC036E3RLA--D001A0000100000000000000

Product Data - 3-10 Ton R410A PKGD Unitary Gas/Electric Rooftop**Item: A1 Qty: 1**

DX cooling, gas heat
High efficiency
Convertible configuration
3 Ton
Major design sequence
208-230/60/3
Microprocessor controls 3ph
Low gas heat 3ph
Economizer Dry Bulb 0-100% with Barometric Relief
Standard condenser coil w/hail guard
Through the base electrical 3ph
Frostat 3ph

Mechanical Specifications - 3-10 Ton R410A PKGD Unitary Gas/Electric Rooftop**Item: A1 Qty: 1****General**

The units shall be convertible airflow. The operating range shall be between 115°F and 0°F in cooling as standard from the factory for units with microprocessor controls. Operating range for units with electromechanical controls shall be between 115°F and 40°F. Cooling performance shall be rated in accordance with ARI testing procedures. All units shall be factory assembled, internally wired, fully charged with R-410A, and 100 percent run tested to check cooling operation, fan and blower rotation, and control sequence before leaving the factory. Wiring internal to the unit shall be colored and numbered for simplified identification. Units shall be cULus listed and labeled, classified in accordance for Central Cooling Air Conditioners.

Casing

Unit casing shall be constructed of zinc coated, heavy gauge, galvanized steel. Exterior surfaces shall be cleaned, phosphatized, and finished with a weather-resistant baked enamel finish. Unit's surface shall be tested 672 hours in a salt spray test in compliance with ASTM B117. Cabinet construction shall allow for all maintenance on one side of the unit. Service panels shall have lifting handles and be removed and reinstalled by removing two fasteners while providing a water and air tight seal. All exposed vertical panels and top covers in the indoor air section shall be insulated with a cleanable foil-faced, fire-retardant permanent, odorless glass fiber material. The base of the unit shall be insulated with 1/8 inch, foil-faced, closed-cell insulation. All insulation edges shall be either captured or sealed. The unit's base pan shall have no penetrations within the perimeter of the curb other than the raised 1 1/8 inch high downflow supply/return openings to provide an added water integrity precaution, if the condensate drain backs up. The base of the unit shall have provisions for forklift and crane lifting, with forklift capabilities on three sides of the unit.

Unit Top

The top cover shall be one piece construction or, where seams exist, it shall be double-hemmed and gasket-sealed. The ribbed top adds extra strength and enhances water removal from unit top.

Filters

Throwaway filters shall be standard on all units. Optional 2-inch MERV 8 and MERV 13 filters shall also be available.

Compressors

All units shall have direct-drive, hermetic, scroll type compressors with centrifugal type oil pumps. Motor shall be suction gas-cooled and shall have a voltage utilization range of plus or minus 10 percent of unit nameplate voltage. Internal overloads shall be provided with the scroll compressors.

Dual compressors are outstanding for humidity control, light load cooling conditions and system back-up applications. Dual compressors are available on 7½-10 ton models and allow for efficient cooling utilizing 3-stages of compressor operation for all high efficiency models.

Notes:

Crankcase heaters are optional on YSC (036, 048, 060, 072, 090, 102, 120); standard on YHC (036, 048, 060, 072, 092, 102, 120).

Indoor Fan

The following units shall be equipped with a direct drive plenum fan design (T/YSC120F, T/YHC074F, T/YHC092F, T/YHC102F, 120F). Plenum fan design shall include a backward-curved fan wheel along with an external rotor direct drive variable speed indoor motor. All plenum fan designs will have a variable speed adjustment potentiometer located in the control box.

3 to 5 ton units (high efficiency 3-phase with optional motor) are belt driven, FC centrifugal fans with adjustable motor sheaves. 3 to 5 ton units (standard and high efficiency 3-phase) have multispeed, direct drive motors. All 6 to 8½ ton units (standard efficiency) shall have belt drive motors with an adjustable idler-arm assembly for quick-adjustment to fan belts and motor sheaves. All motors shall be thermally protected. All 10 tons, 6 ton (074), 7½ to 8½ (high efficiency) units have variable speed direct drive motors. All indoor fan motors meet the U.S. Energy Policy Act of 1992 (EPACT).

Outdoor Fans

The outdoor fan shall be direct-drive, statically and dynamically balanced, draw-through in the vertical discharge position. The fan motor shall be permanently lubricated and shall have built-in thermal overload protection.

Evaporator and Condenser Coils

Internally finned, 5/16" copper tubes mechanically bonded to a configured aluminum plate fin shall be standard. Evaporator coils are standard for all 3 to 10 ton standard efficiency models. Microchannel condenser coils are standard

for all 3 to 10 ton standard efficiency models and 4, 5, 6, 7.5, 8.5 ton high efficiency models. The microchannel type condenser coil is not offered on the 4 and 5 ton dehumidification model. Due to flat streamlined tubes with small ports, and metallurgical tube-to-fin bond, microchannel coil has better heat transfer performance. Microchannel condenser coil can reduce system refrigerant charge by up to 50% because of smaller internal volume, which leads to better compressor reliability. Compact all-aluminum microchannel coils also help to reduce the unit weight. These all aluminum coils are recyclable. Galvanic corrosion is also minimized due to all aluminum construction. Strong aluminum brazed structure provides better fin protection. In addition, flat streamlined tubes also make microchannel coils more dust resistant and easier to clean. Coils shall be leak tested at the factory to ensure the pressure integrity. The evaporator coil and condenser coil shall be leak tested to 600 psig. The assembled unit shall be leak tested to 465 psig. The condenser coil shall have a patent pending 1+1+1 hybrid coil designed with slight gaps for ease of cleaning. A plastic, dual-sloped, removable and reversible condensate drain pan with through-the-base condensate drain is standard.

Tool-less Hail Guards

Tool-less, hail protection quality coil guards are available for condenser coil protection.

Controls

Unit shall be completely factory-wired with necessary controls and contactor pressure lugs or terminal block for power wiring. Unit shall provide an external location for mounting a fused disconnect device. A choice of microprocessor or electromechanical controls shall be available. Microprocessor controls provide for all 24V control functions. The resident control algorithms shall make all heating, cooling, and/or ventilating decisions in response to electronic signals from sensors measuring indoor and outdoor temperatures. The control algorithm maintains accurate temperature control, minimizes drift from set point, and provides better building comfort. A centralized microprocessor shall provide anti-short cycle timing and time delay between compressors to provide a higher level of machine protection. 24-volt electromechanical control circuit shall include control transformer and contactor

High Pressure Control

All units include High Pressure Cutout as standard.

Phase monitor

Phase monitor shall provide 100% protection for motors and compressors against problems caused by phase loss, phase imbalance, and phase reversal. Phase monitor is equipped with an LED that provides an ON or FAULT indicator. There are no field adjustments. The module will automatically reset from a fault condition.

Refrigerant Circuits

Each refrigerant circuit offer thermal expansion valve as standard. Service pressure ports, and refrigerant line filter driers are factory-installed as standard. An area shall be provided for replacement suction line driers.

Gas Heating Section

The heating section shall have a progressive tubular heat exchanger design using stainless steel burners and corrosion resistant steel throughout. An induced draft combustion blower shall be used to pull the combustion products through the firing tubes. The heater shall use a direct spark ignition (DSI) system. On initial call for heat, the combustion blower shall purge the heat exchanger for 20 seconds before ignition. After three unsuccessful ignition attempts, the entire heating system shall be locked out until manually reset at the thermostat/zone sensor. Units shall be suitable for use with natural gas or propane (field-installed kit) and also comply with the California requirement for low NOx emissions (Gas/Electric Only).

Economizer

This accessory shall be available with or without barometric relief. The assembly includes fully modulating 0-100 percent motor and dampers, minimum position setting, preset linkage, wiring harness with plug, spring return actuator and fixed dry bulb control. The barometric relief shall provide a pressure operated damper that shall be gravity closing and shall prohibit entrance of outside air during the equipment off cycle. Optional solid state or differential enthalpy control shall be available for either factory or field installation. The economizer arrives in the shipping position and shall be moved to the operating position by the installing contractor.

Through the Base Electrical Access

An electrical service entrance shall be provided allowing electrical access for both control and main power connections inside the curb and through the base of the unit. Option will allow for field installation of liquid-tight conduit and an external field-installed disconnect switch.

Frostat

This option is to be utilized as a safety device. The Frostat opens when temperatures on the evaporator coil fall below

10°F. The temperature will need to rise to 50°F before closing. This option should be utilized in low airflow or high outside air applications. (Cooling with Electric Heat Only.)

Frostat

This option is to be utilized as a safety device. The Frostat opens when temperatures on the evaporator coil fall below 10°F. The temperature will need to rise to 50°F before closing. This feature should be utilized in low airflow or high outside air applications (cooling only).

Unit Dimensions - 3-10 Ton R410A PKGD Unitary Gas/Electric Rooftop
Item: A1 Qty: 1

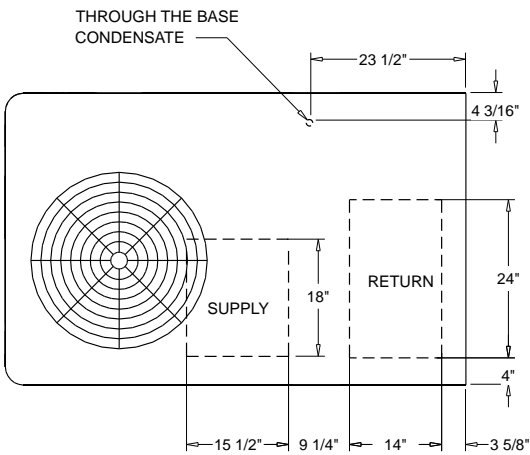
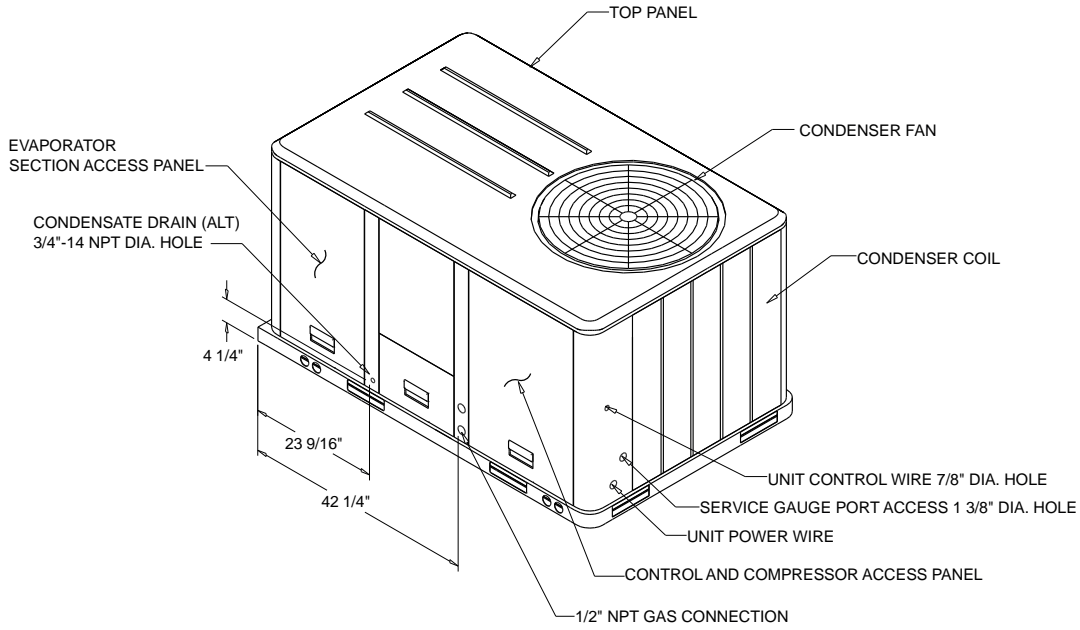

- NOTES:
 1. THRU -THE -BASE GAS AND ELECTRICAL IS NOT STANDARD ON ALL UNITS.
 2. VERIFY WEIGHT, CONNECTION, AND ALL DIMENSION WITH INSTALLER DOCUMENTS BEFORE INSTALLATION

PLAN VIEW UNIT
 DIMENSION DRAWING

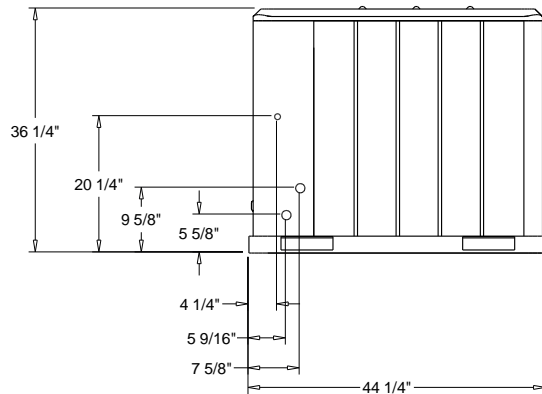
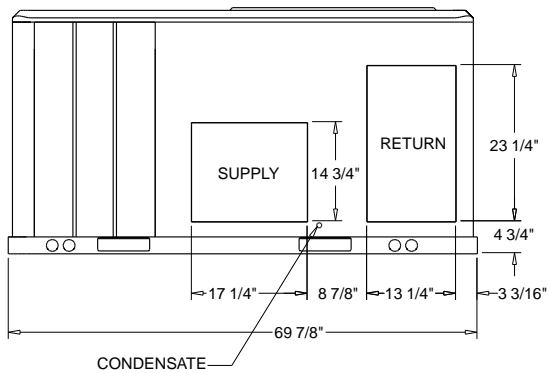

HORIZONTAL AIR FLOW

PACKAGED GAS / ELECTRICAL
 DIMENSION DRAWING

Unit Dimensions - 3-10 Ton R410A PKGD Unitary Gas/Electric Rooftop
Item: A1 Qty: 1

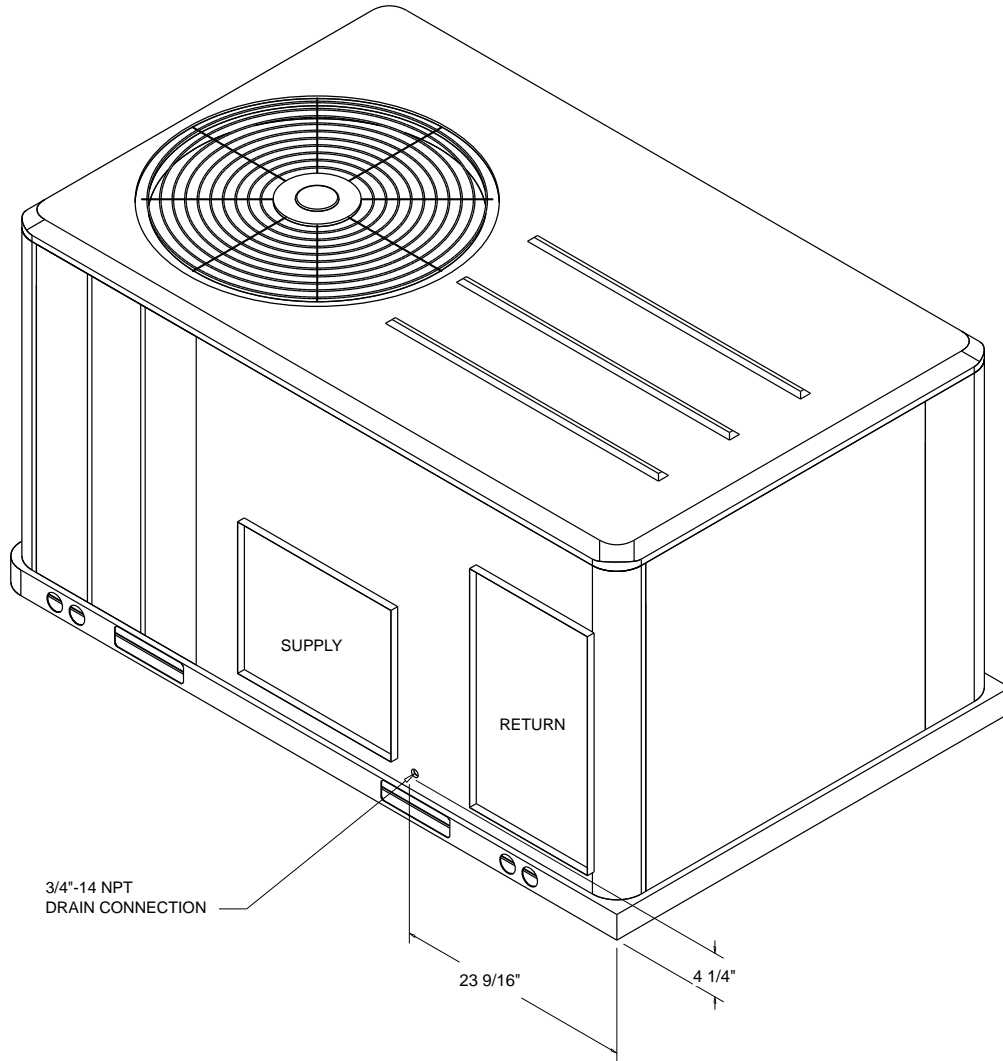

ISOMETRIC-PACKAGED COOLING

Unit Dimensions - 3-10 Ton R410A PKGD Unitary Gas/Electric Rooftop

Item: A1 Qty: 1

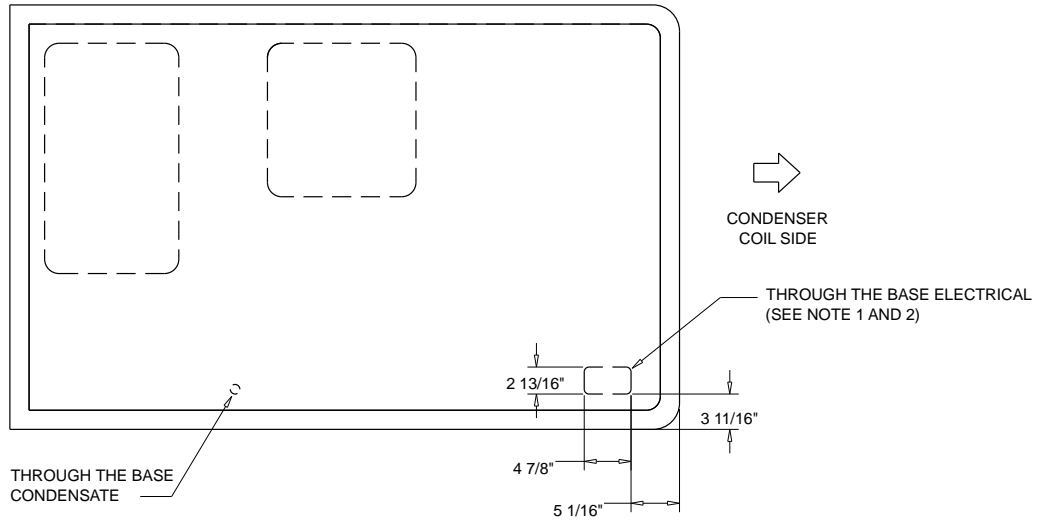
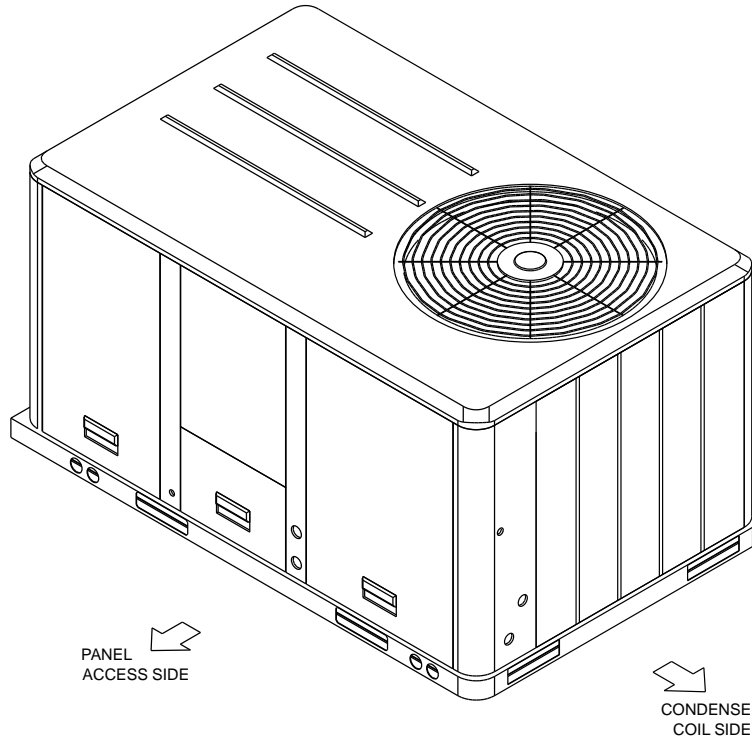

- NOTES:
1. THRU -THE -BASE GAS AND ELECTRICAL IS NOT STANDARD. VERIFY OPTION IN PRODUCT DATA IN THIS DOCUMENT.
 2. VERIFY WEIGHT, CONNECTION, OPTION CONFIGURATION AND ALL DIMENSION WITH INSTALLER DOCUMENTS BEFORE INSTALLATION

THRU THE BASE ELECTRICAL
 PLAN / ISO VIEW DRAWING

Weight, Clearance & Rigging Diagram - 3-10 Ton R410A PKGD Unitary Gas/Electric Rooftop
Item: A1 Qty: 1

INSTALLED ACCESSORIES NET WEIGHT DATA

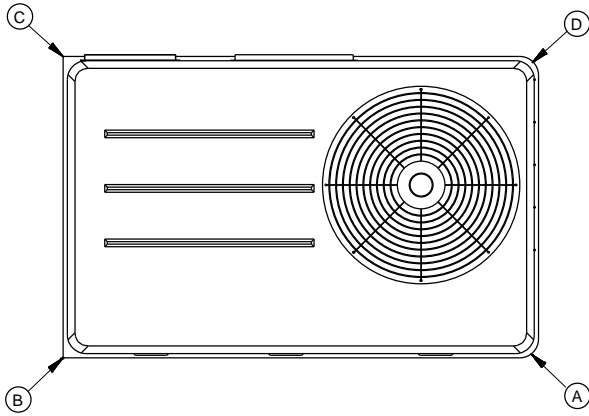

PACKAGED GAS / ELECTRICAL
 CORNER WEIGHT

ACCESSORY		WEIGHTS			
ECONOMIZER		26.0 lb			
MOTORIZED OUTSIDE AIR DAMPER					
MANUAL OUTSIDE AIR DAMPER					
BAROMETRIC RELIEF					
OVERSIZED MOTOR					
BELT DRIVE MOTOR					
POWER EXHAUST					
THROUGH THE BASE ELECTRICAL/GAS (FIOPS)		8.0 lb			
UNIT MOUNTED CIRCUIT BREAKER (FIOPS)					
UNIT MOUNTED DISCONNECT (FIOPS)					
POWERED CONVENIENCE OUTLET (FIOPS)					
HINGED DOORS (FIOPS)					
HAIL GUARD		12.0 lb			
SMOKE DETECTOR, SUPPLY / RETURN					
NOVAR CONTROL					
STAINLESS STEEL HEAT EXCHANGER					
REHEAT					
ROOF CURB					
BASIC UNIT WEIGHTS		CORNER WEIGHTS		CENTER OF GRAVITY	
SHIPPING	NET	(A)	(C)	(E) LENGHT	(F) WIDTH
607.0 lb	532.0 lb	(B)	(D)	31"	19"

NOTE:

1. All weights are approximate.
2. Weights for options that are not list refer to Installation guide.
3. The actual weight are listed on the unit nameplate.
4. Refer to unit nameplate and installation guide for weights before scheduling transportation and installation of unit.
5. The weight shown represents the typical unit operating weight for the configuration selected. Estimated at +/- 10 % of the nameplate weight. .
6. Verify weight, connection, and all dimension with installer documents before installation.
7. Corner weights are given for information only.
8. Net/Shipping weight of optional accessories should be added to unit weight when ordering factory or field installed accessories.

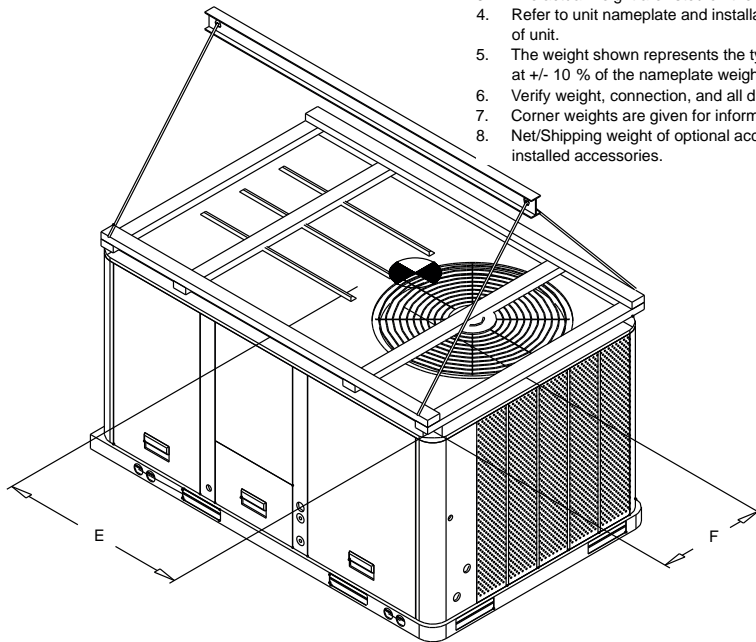

PACKAGED GAS / ELECTRICAL
 RIGGING AND CENTER OF GRAVITY

Weight, Clearance & Rigging Diagram - 3-10 Ton R410A PKGD Unitary Gas/Electric Rooftop
Item: A1 Qty: 1

CLEARANCE FROM TOP OF UNIT 72"

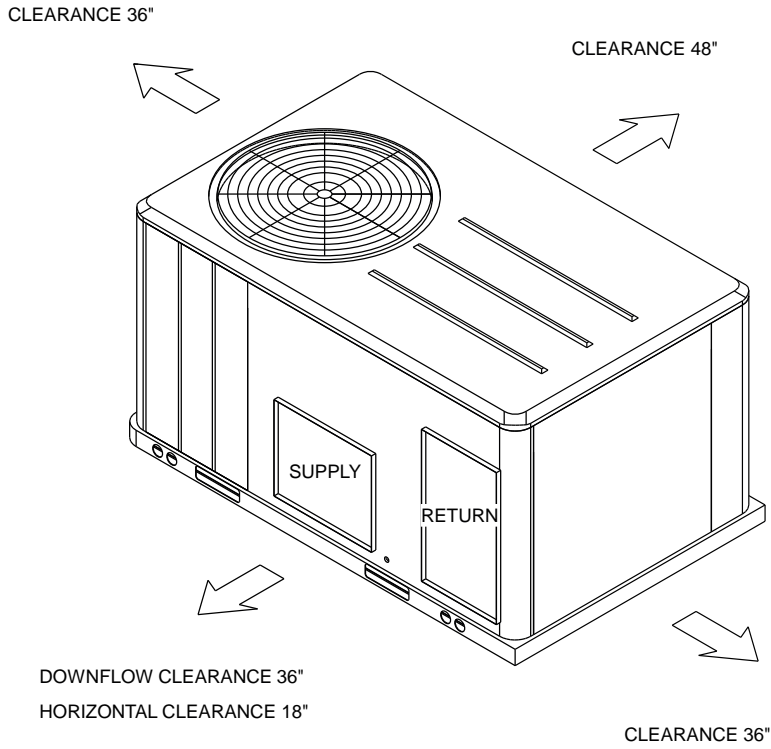

PACKAGED GAS / ELECTRIC
CLEARANCE

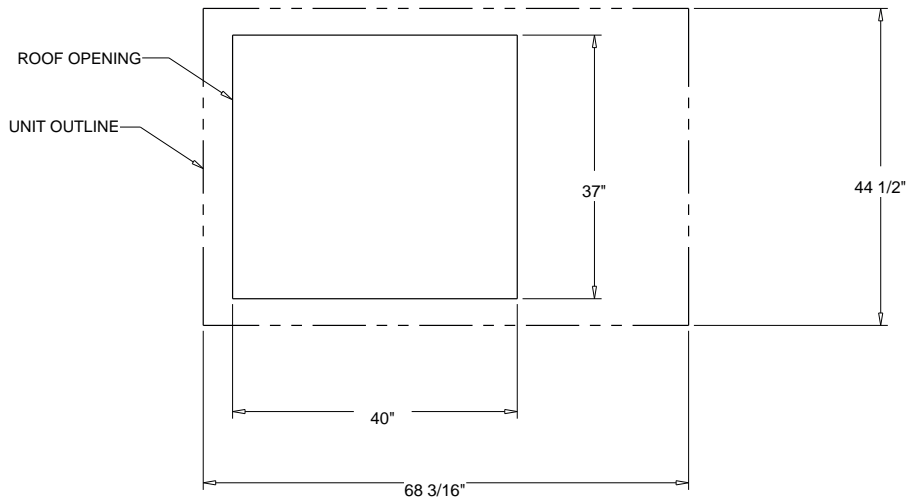

PACKAGED GAS / ELECTRIC
DOWNFLOW TYPICAL ROOF OPENING

Accessory - 3-10 Ton R410A PKGD Unitary Gas/Electric Rooftop
Item: A1 Qty: 1

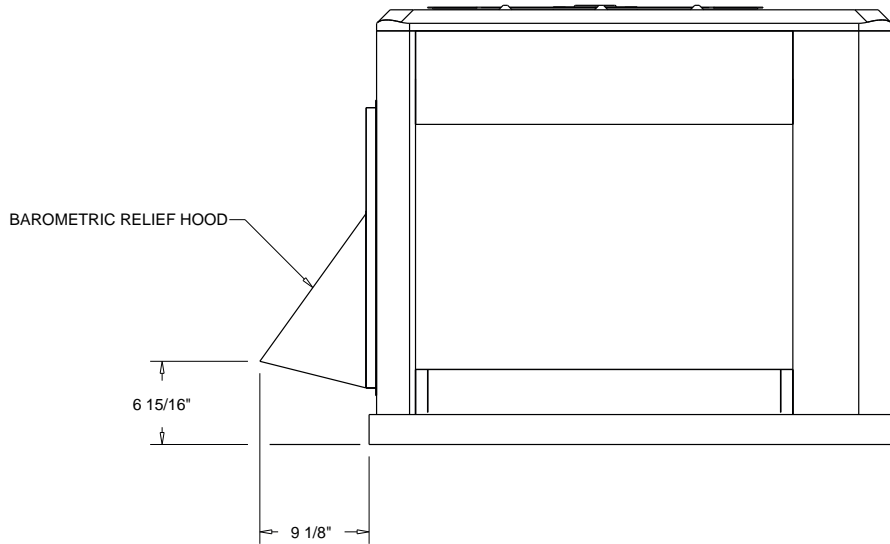
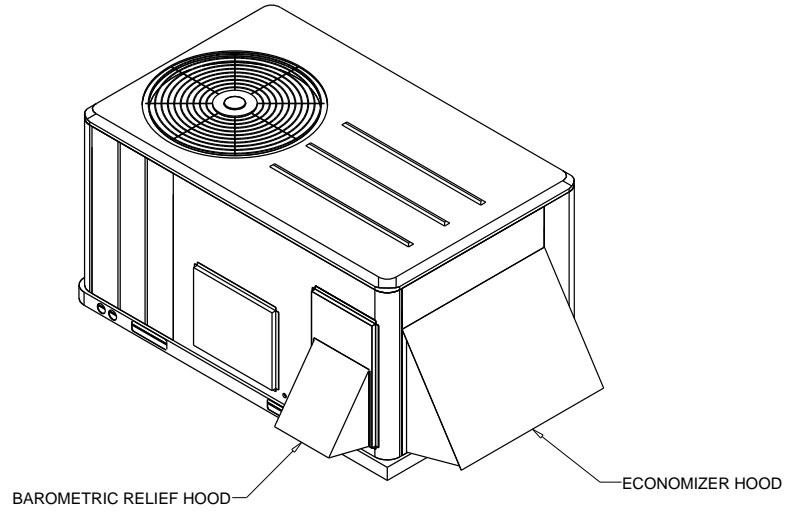

ACCESSORY - BAROMETRIC RELIEF DAMPER HOOD

Accessory - 3-10 Ton R410A PKGD Unitary Gas/Electric Rooftop

Item: A1 Qty: 1

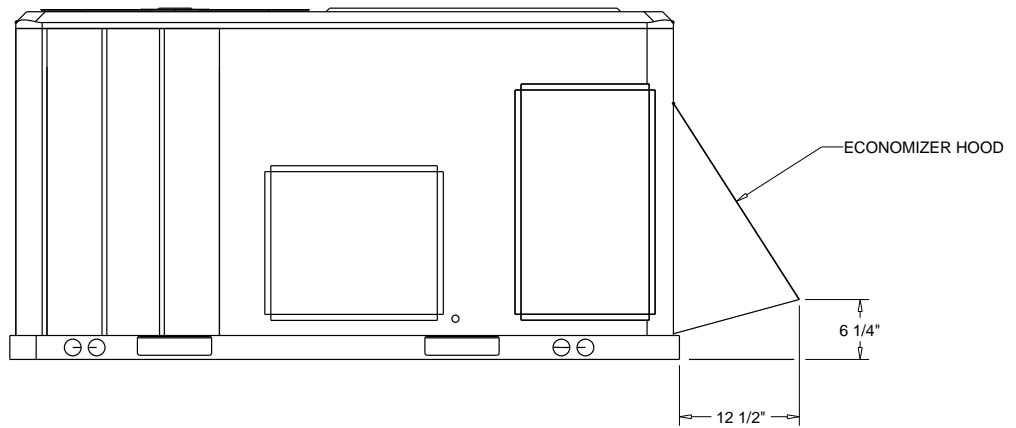
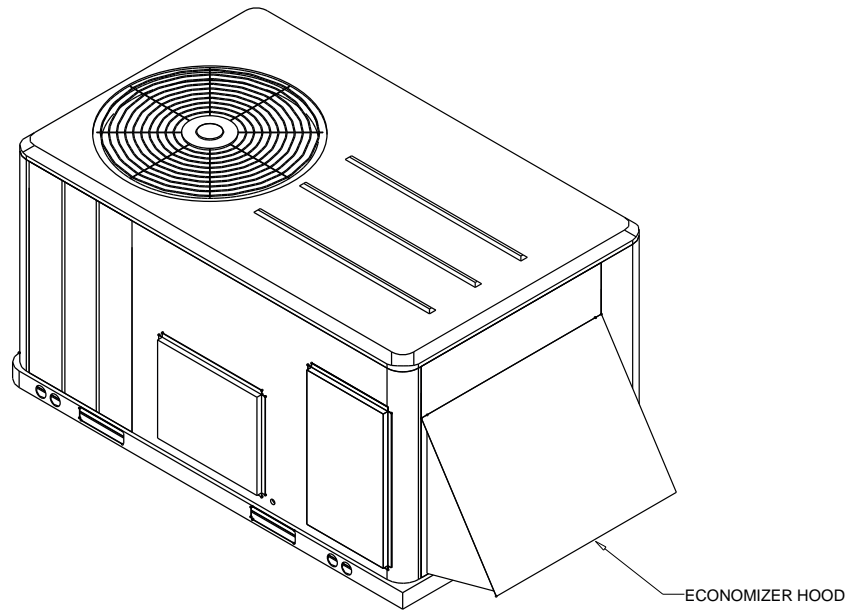

ACCESSORY - ECONOMIZER HOOD