



Submittal

Prepared For:
All Bidders

Date: February 15, 2018

Customer P.O. Number:
Customer Project Number:

Sold To:

Job Number:
Job Name:
HVAC Services - Rob - Bishop Street

Trane U.S. Inc. dba Trane is pleased to provide the enclosed submittal for your review and approval.

Product Summary

Qty	Product
2	Split System Air Conditioning Units (Small)

Daniel Broderick
Trane
860 Spring Street, Unit 1
Westbrook, ME 04092
Phone: (207) 828-1777
Fax: (207) 828-1511

The attached information describes the equipment we propose to furnish for this project, and is submitted for your approval.

Product performance and submittal data is valid for a period of 6 months from the date of submittal generation. If six months or more has elapsed between submittal generation and equipment release, the product performance and submittal data will need to be verified. It is the customer's responsibility to obtain such verification.

Table Of Contents

Product Summary 1

Split System Air Conditioning Units (Small) (Item A1)

 Tag Data 3

 Product Data 3

 Mechanical Specifications 4

 Unit Dimensions 6

Tag Data - Split System Air Conditioning Units (Small) (Qty: 2)

Item	Tag(s)	Qty	Description	Model Number
A1	No Tag	2	4 Ton Unitary Split Systems	4TTA3048D3 - TUH1C080A9601-4TXCC009DS3HC

Product Data - Split System Air Conditioning Units (Small)

Item: A1 Qty: 2

Split System Cooling Outdoor Unit
 4 Ton Nominal Cooling Capacity
 200 - 230 Volt 3 Phase 60 Hertz

Furnace unit
 80,000 Heating input BTUH
 115 Volt/1 phase/60 hertz

5 Ton Airflow Cooling Capacity
 Cased upflow/dnflow/horiz left
 21.0"/19.8" cabinet
 Brazed
 60,000 Nominal cooling capacity
 Hi efficiency
 TXV-Non bleed
 Heat pump
 Conv-upflow/dnflw,left airflow coil

Mechanical Specifications - Split System Air Conditioning Units (Small)

Item: A1 Qty: 2

4TTA3 - General

This unit is fully charged from the factory for matched indoor section and up to 180" of piping. Unit is designed to operate at outdoor ambient temperatures as high as 115.0 F]. Cooling capacities matched with a wide selection of air handlers and furnace coils that are A.R.I certified. The unit shall be UL listed. Exterior must be designed for outdoor application.

4TTA3 - Casing

Unit casing is constructed of heavy gauge, galvanized steel and painted with a weather-resistant powder paint. Corrosion and weatherproof CMBP-G30 Duratuff base.

4TTA3 - Compressor

The Climatuff compressor features internal over temperature and pressure protector, total dipped hermetic motor. Other features include: centrifugal oil pump, and low vibration and noise.

4TTA3 - Condenser Coil

The Spine Fin coil is continuously wrapped, corrosion resistant, all aluminum with minimum brazed joints. The coil is 3/8" O.D. seamless aluminum glued to a continuous aluminum fin. Coils are lab tested to withstand 2000.0 lb of pressure per square inch. The outdoor coil provides low airflow resistance and efficient heat transfer.

4TTA3 - Refrigerant controls

Refrigeration system controls include condenser fan and compressor contactor. High and low pressure protection is inherent to the compressor. Another standard feature is the factory installed liquid line drier.

TUH1 - GENERAL OPERATION

These High Efficiency, Direct Vent, Condensing Gas Furnaces employ a Hot Surface Ignition system, which eliminates the waste of a constantly burning pilot. They are convertible for HORIZONTAL use by rotating the unit to its left side. The integrated system control lights the main burners upon a demand for heat from the room thermostat. Complete front service access.

- a. Low energy power venter.
- b. Vent proving differential switch.

TUH1 - NATURAL GAS MODELS

Central heating furnace designs are certified by the American Gas Association for both natural and L.P. gas. Limit setting and rating data were established and approved under standard rating conditions using American National Standards Institute standards.

TUH1 - SAFE OPERATION

The Integrated System Control has solid state devices, which continuously monitor for presence of flame, when the system is in the heating mode of operation. Slow opening, dual solenoid combination gas valve and regulator provide extra safety and quieter operation.

TUH1 - QUICK HEATING

Durable, cycle tested, heavy gauge **aluminized steel heat exchanger and stainless steel secondary heat exchanger** quickly transfer over 90% of the heat to provide warm conditioned air to the structure. **Low energy power vent blower**, to increase efficiency and provide a positive discharge of gas fumes to the outside as it draws outdoor air in for sealed combustion, which means it uses no indoor air for combustion.

TUH1 - BURNERS

Multi-port, in-shot burners will give years of quiet and efficient service. All models can be converted to **L.P. gas** without changing burners.

TUH1 - INTEGRATED SYSTEM CONTROL

Exclusively designed operational program provides total control of furnace limit sensors, blowers, gas valve, flame control and includes self diagnostics for ease of service. The built-in, selectable "**Cooling Fan Off**" feature provides time-delay capability like a BAY24X045 Time-Delay Kit for cooling operation. Also contains connection points for E.A.C./humidifier.

TUH1 - AIR DELIVERY

The multispeed, directdrive blower motor, with sufficient airflow range for most heating and cooling requirements, will switch from heating to cooling speeds on demand from room thermostat. The blower door safety switch will prevent or terminate furnace operation when the blower door is removed. (Fan relay and 35VA control transformer is standard).

TUH1 - STYLING

Heavy gauge steel and "wraparound" cabinet construction is used in the cabinet with baked-on enamel finish for strength and beauty. The heat exchanger section of the cabinet is completely lined with foil-faced fiberglass insulation. This results in quiet and efficient operation due to the excellent acoustical and insulating qualities of fiberglass.

4TXC - General

Upflow, Downflow, or Horizontal coils shall be designed for cooling and heat pump applications. The coil shall be 3/8" seamless aluminum tubing me-chanically bonded to aluminum plate fin.

Refrigerant for the TXC coils shall be controlled with factory installed Non-Bleed TXV refrigerant control. Refrigerant connections are brazed fittings with an additional Schrader Valve for system service.

The coil cabinet shall have a removable front and interior access panel for evaporator coil entering air surface cleaning. The coil includes a drain pan with drain connections for vertical or horizontal operation and a horizontal auxiliary drain pan.

These coils are A.R.I. certified with Trane's matching condensing units.

4TXC - Accessories

Evaporator Defrost Control installed on coil for lower ambient operating conditions.

Unit Dimensions - Split System Air Conditioning Units (Small)

Item: A1 Qty: 2

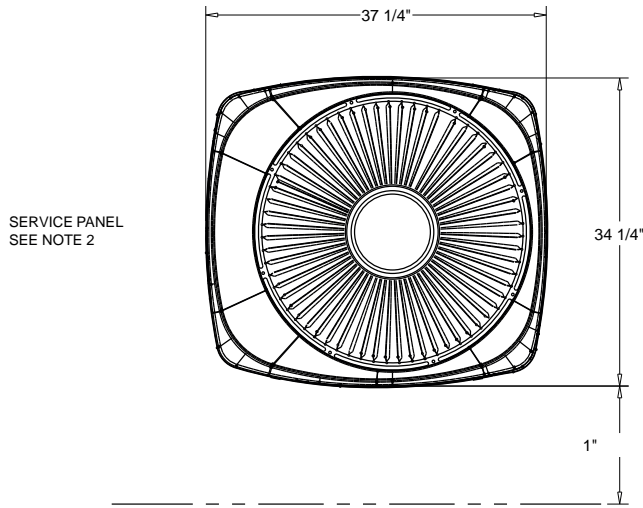

UNIT DIMENSTIONS	
DIM - D	7/8"
DIM - E	3/8"

NOTES

1. TOP DISCHARGE AREA SHOULD BE UNRESTRICTED FOR AT LEAST 60" ABOVE UNIT. UNIT SHOULD BE PLACED SO ROOF RUN-OFF WATER DOES NOT POUR DIRECTLY ON UNIT, AND SHOULD BE AT LEAST 12" FROM WALL AND ALL SURROUNDING SHRUBBERY ON TWO SIDES. OTHER TWO SIDES UNRESTRICTED.
2. ELECTRICAL AND REFRIGERANT COMPONENT CLEARANCES PER PREVAILING CODES.

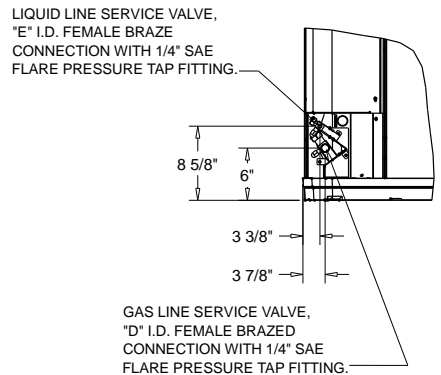
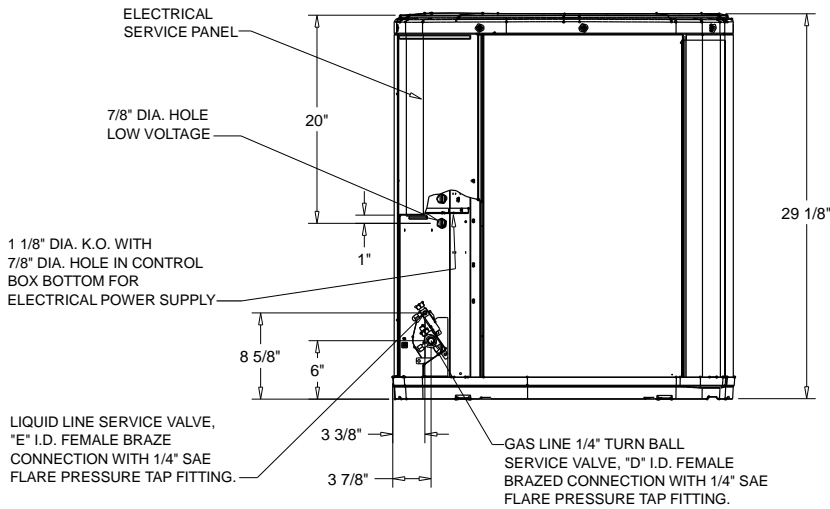

Unit Dimensions - Split System Air Conditioning Units (Small)

Item: A1 Qty: 2

ELECTRICAL / GENERAL DATA

<p>GENERAL</p> <p>Model: 4TTA3048*</p> <p>Operating Voltage: 187-253</p> <p>Unit Primary Voltage: 208</p> <p>Unit Secondary Voltage: 230</p> <p>Unit Hertz: 60</p> <p>Unit Phase: 3</p>	<p>POWER CONN.</p> <p>Minimum Circuit Ampacity: 18.0</p> <p>Maximum Circuit Breaker: 30.0</p> <p>Minimum Protection Rating: 30.0</p>	<p>COMPRESSOR</p> <p>Number: 1</p> <p>Phase: 3</p> <p>Rated Load Amps: 13.7</p> <p>Locked Rotor Amps: 83.0</p>
<p>OUTDOOR MOTOR</p> <p>Number: 1</p> <p>Horsepower: 0.20</p> <p>Motor Speed (RPM): 825</p> <p>Phase: 3</p> <p>Full Load Amps: 0.93</p> <p>Locked Rotor Amps: -</p>	<p>NOTES:</p> <p>1. Certified in accordance with the Unitary Air-Conditioner equipment certification program which is based on AHRI Standard 210/240.</p> <p>2. Calculated in accordance with N.E.C. Use only HACR circuit breakers or fuses.</p> <p>3. Standard line lengths - 60'. Standard lift - 60' Suction and Liquid line.</p> <p>For Greater lengths and lifts refer to refrigerant piping software Pub# 32-3312-0</p> <p>4. * = 15, 20, 25, 30, 40 and 50 foot lineset available.</p>	
<p>REFRIGERANT</p> <p>Type: R-410</p> <p>Charge: 6.8 lb</p> <p>Line Size O.D. Gas: 7/8"</p> <p>Line Size O.D. LIQ: 3/8"</p>		

WEIGHT	
NET	203"
SHIPPING	235.0 lb

NOTES:

- C1. TOP DISCHARGE SHOULD BE UNRESTRICTED FOR AT LEAST 60" ABOVE UNIT
- C2. PLACE UNIT FROM WALL
- C3. PLACE SHRUBBERY AT LEAST 12" FROM UNIT ON TWO SIDES, OTHER SIDES UNRESTRICTED
- C4. PLACE UNIT SO ROOF RUN-OFF DOES NOT FALL DIRECTLY ON UNIT

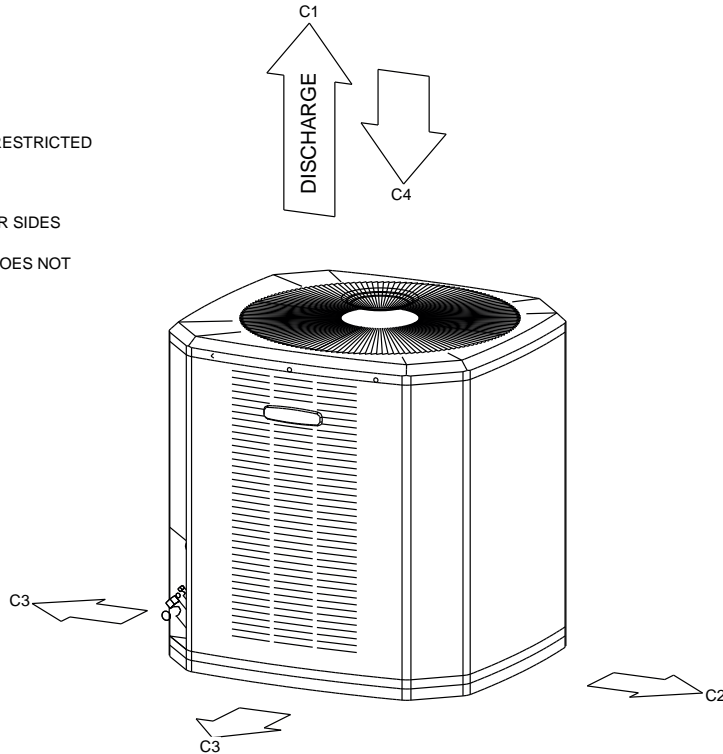

WEIGHT AND CLEARANCE

Unit Dimensions - Split System Air Conditioning Units (Small)

Item: A1 Qty: 2

ELECTRICAL / GENERAL DATA

<p>GENERAL - POWER CONN ⁽⁴⁾</p> <p>Model: TUH1C080A9601A</p> <p>Voltage: 115/1/60</p> <p>Ampacity (Amps): 13.5</p> <p>Max Over. Pro. (Amps): 20.0</p>	<p>COMBUSTION FAN</p> <p>Type: Centrifugal</p> <p>Motor HP: 0.05</p> <p>Motor Speed RPM: 3450</p> <p>Phase: 1</p> <p>Full Load Amps: 0.71</p>	<p>BLOWER DRIVE</p> <p>Drive: Direct *</p> <p>No. Used: 1</p> <p>Motor HP: 0.75</p> <p>Speed RPM: 1100</p> <p>Phase: 1</p>
<p>ORIFICES</p> <p>Nat. Gas Qty - Drill Size: 4 - 45</p> <p>L.P. Gas Qty. - Drill Size: 4 - 56</p> <p>Gas Valve: Redundant - single Stage</p>	<p>Heat ⁽²⁾⁽³⁾</p> <p>Input BTUH: 80,000</p> <p>Capacity BTUH (ICS): 76,000</p> <p>AFUE (ICS): 95.0</p> <p>Temp. Rise (Min.-Max): 35-60</p>	<p>FILTERS</p> <p>Type: High Velocity</p> <p>Furnished: No</p> <p>Number: 1</p> <p>Recommended: 20"x25"x1"</p>

NOTES:

1. Central Furnace heating designs are certified by AGA and CSA.
2. For U.S. applications, above input ratings (BTUH) are up to 2,000 feet, derate 4 percent per 1,000 feet for elevations above 2,000 feet above sea level. For Canadian applications, above input ratings (BTUH) are up to 4,500 feet, derate 4 percent per 1,000 feet for elevations above 4,500 feet above sea level.
3. Based on U.S. government standard tests.
4. The above wiring specifications are in accordance with National Electrical Code; however, installations must comply with local codes.

WEIGHT (AIR HANDLER ONLY)	
SHIPPING:	171.0 lb
NET:	160.0 lb

UNIT CLEARANCE TABLE			
MINIMUM CLEARANCE TO COMBUSTIBLE MATERIALS			
SIDE	0	TOP	1"
REAR	0	FLUE	0
FRONT	3"		
HORIZONTAL (FLUE DISCHARGE ON LEFT) ALCOVE			
SIDE RIGHT	0	FRONT	18"
SIDE LEFT	0	TOP	1"
REAR	6"	FLUE	0
CLOSET			
SIDE RIGHT	1"	FRONT	3"
SIDE LEFT	1"	TOP	1"
REAR	3"	FLUE	0

NOTES:
 *UH1B080A9H31A, *UH1C100A9H41, & *UH1D120A9H51 REQUIRES 3" DIAMETER VENT PIPE.
 DIAMETER OF VENT PIPE MAY BE LIMITED TO 2 1/2" OR 3" ON SOME MODELS AT DIFFERENT ALTITUDES. REFER TO THE VENT LENGTH TABLE FOR PROPER APPLICATION.

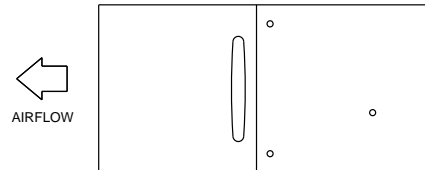
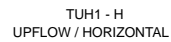
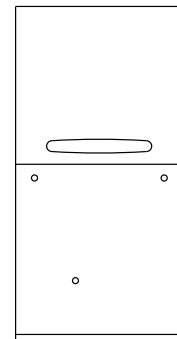

Unit Dimensions - Split System Air Conditioning Units (Small)

Item: A1 Qty: 2

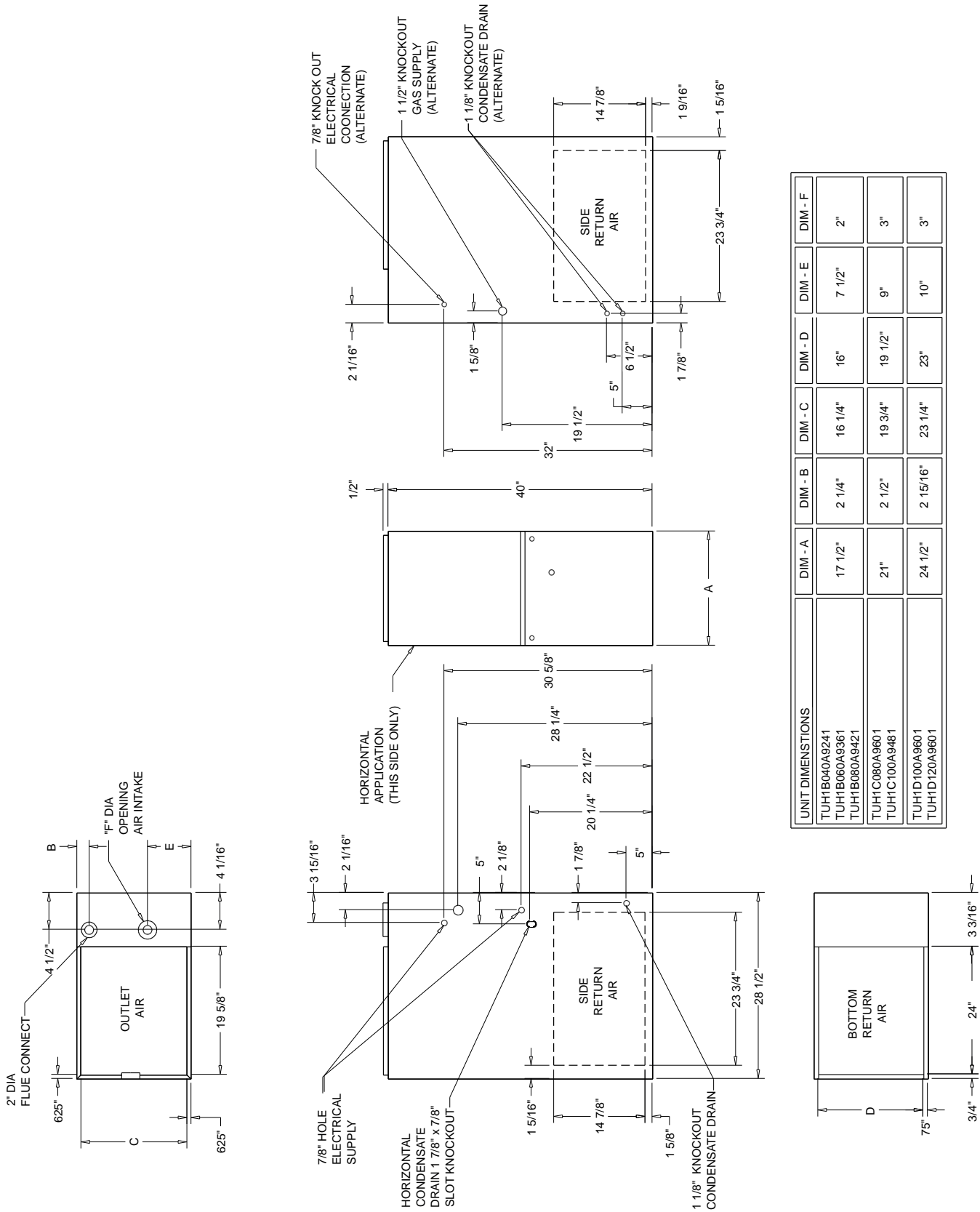

UNIT DIMENSTIONS	DIM - A	DIM - B	DIM - C	DIM - D	DIM - E	DIM - F
TUH1B040A9241	17 1/2"	2 1/4"	16 1/4"	16"	7 1/2"	2"
TUH1B060A9361	21"	2 1/2"	19 3/4"	19 1/2"	9"	3"
TUH1B080A9421	24 1/2"	2 15/16"	23 1/4"	23"	10"	3"

Unit Dimensions - Split System Air Conditioning Units (Small)

Item: A1 Qty: 2

4TXCD009	
DIMENSION (A)	30 11/16"
DIMENSION (B)	21"
DIMENSION (C)	20 1/8"
DIMENSION (D)	19 1/4"
MATCHED FURNACE WIDTH	24 1/2"
GAS CONNECTION	3/4" BRAZE
LIQUID CONNECTION	3/8" BRAZE
REFRIGERANT CONTROL	TXV (NON-BLEED)
DRAIN PAN	PLASTIC
WEIGHT NET	68.0 lb

