

1 SLAB-ON-DECKING SECTION
S2.1 Scale: 3/4" = 1'-0"

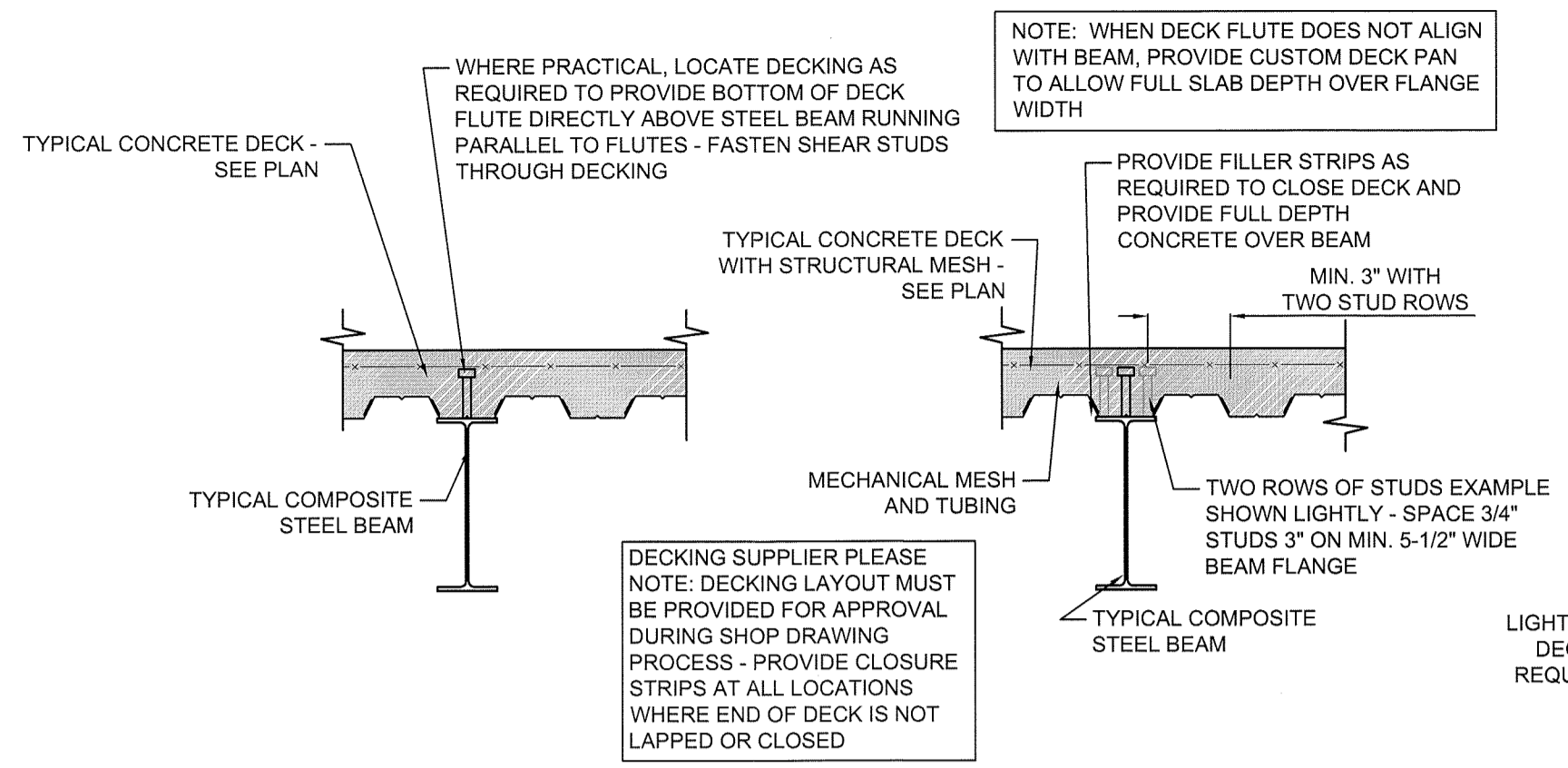

2 COMPOSITE SLAB-ON-DECKING DETAIL
S2.1 Scale: 3/4" = 1'-0"

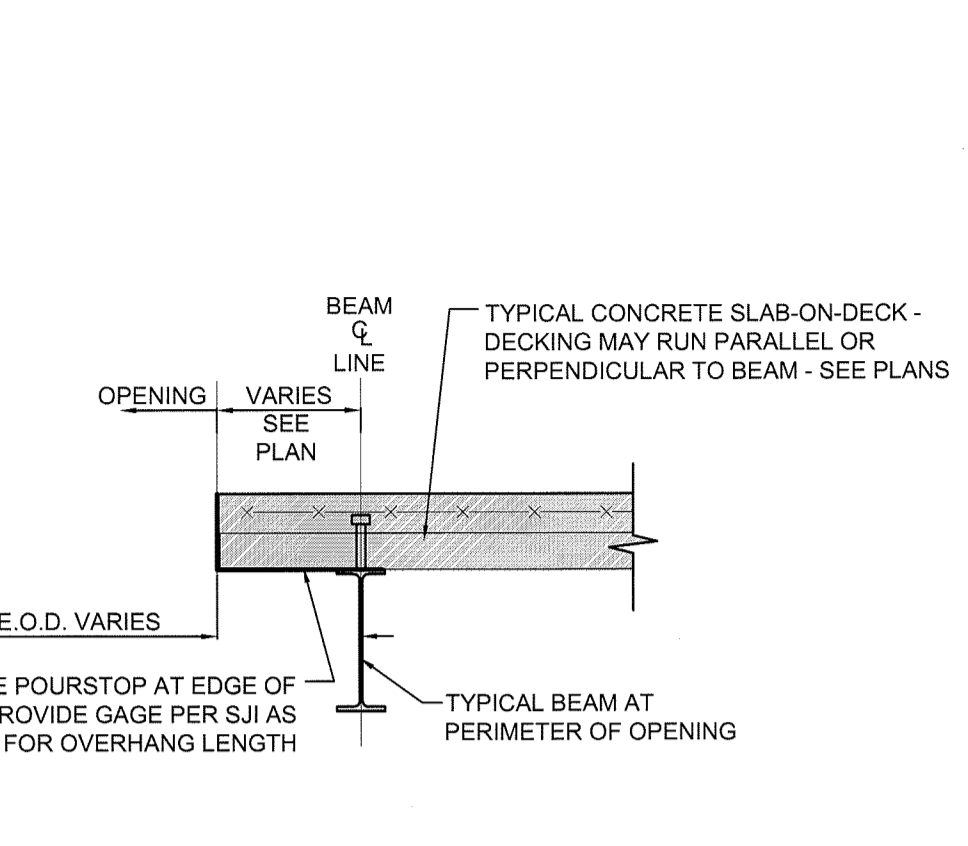

3 EDGE OF SLAB-ON-DECKING
S2.1 Scale: 3/4" = 1'-0"

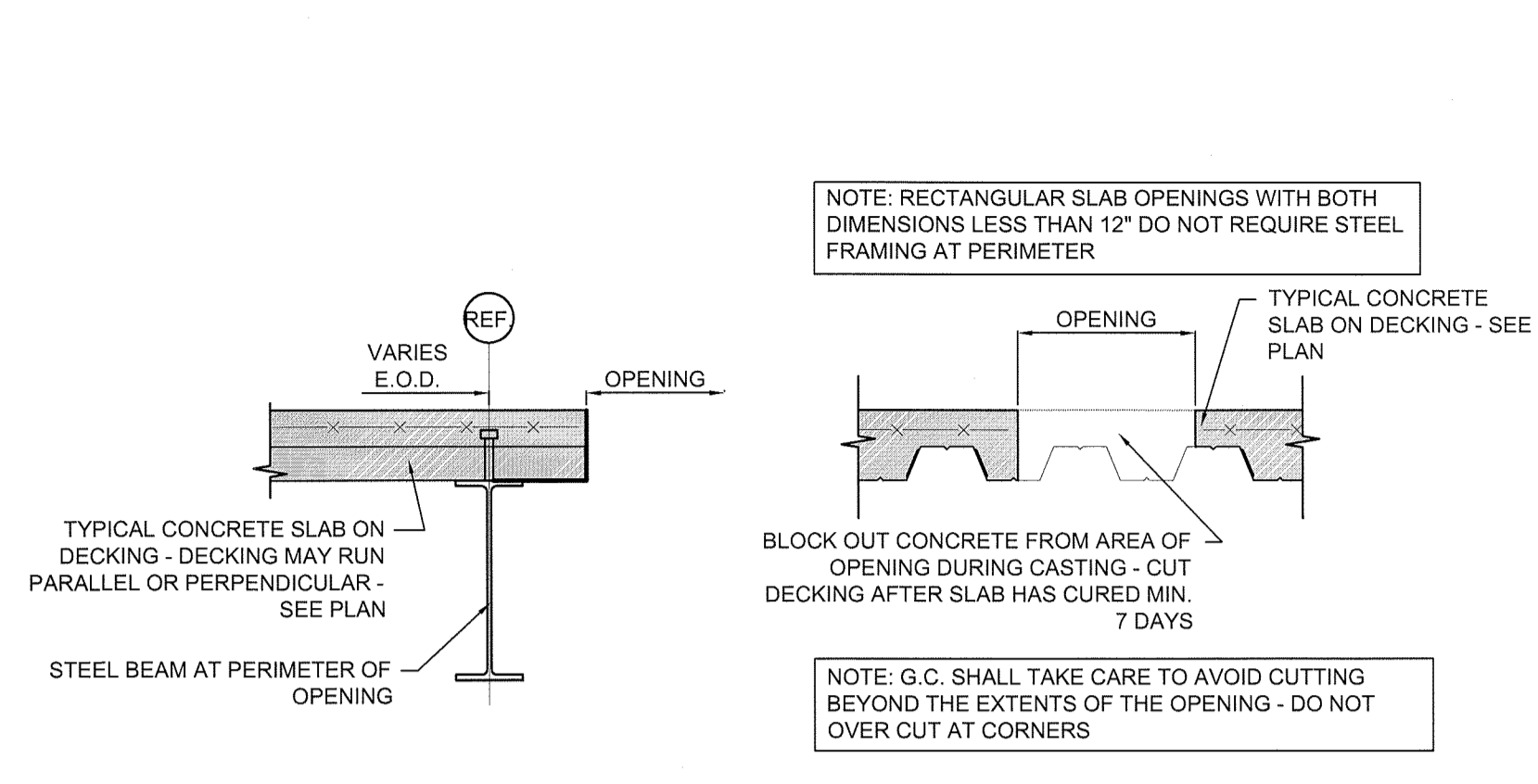

4 SLAB-ON-DECKING OPENINGS
S2.1 Scale: 3/4" = 1'-0"

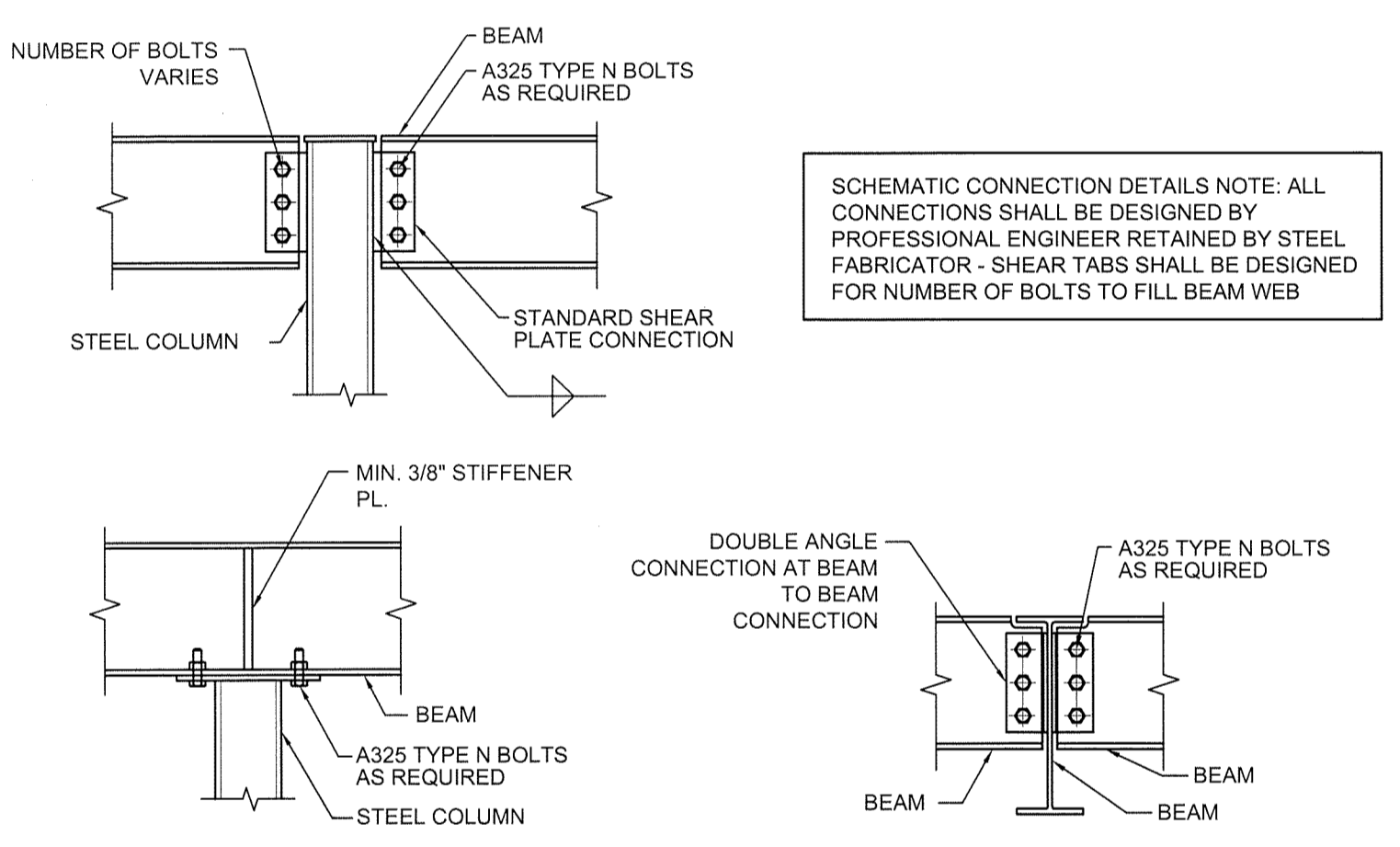

A STEEL CONNECTION DETAILS
S2.1 Scale: 3/4" = 1'-0"

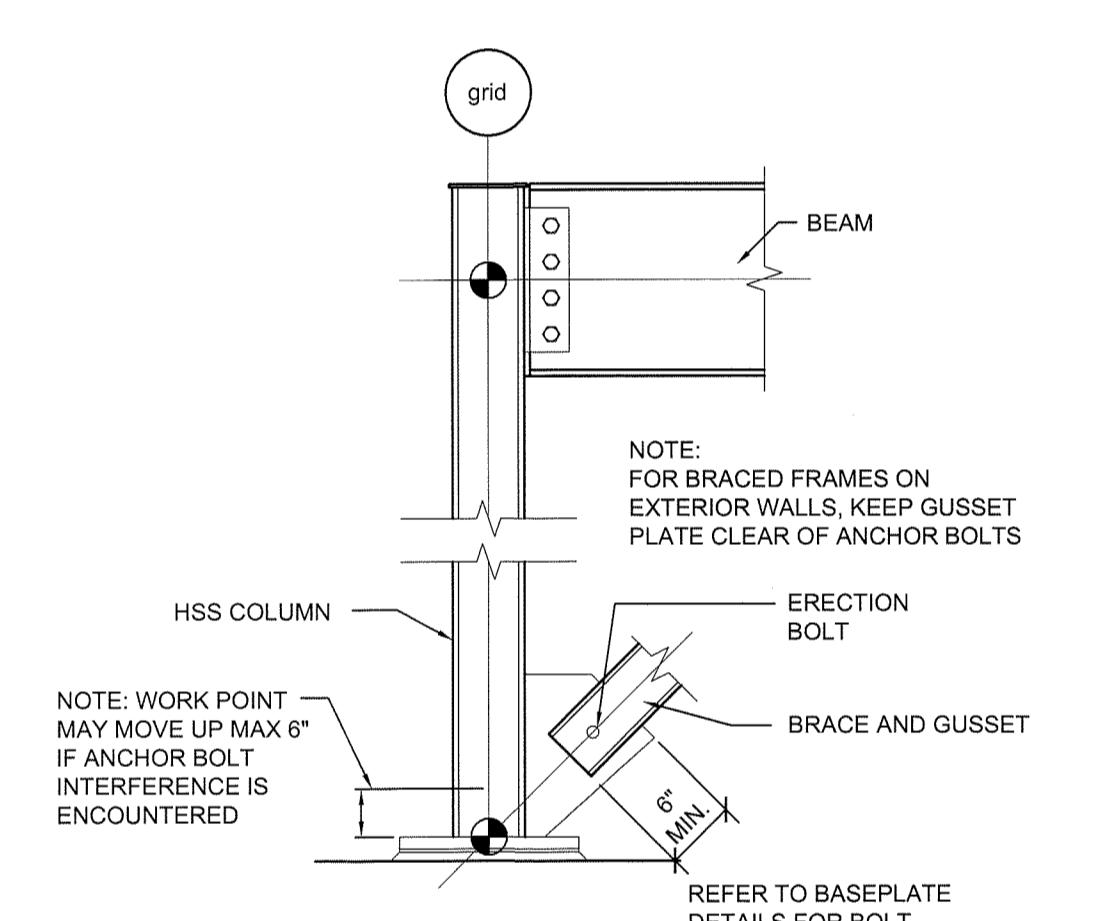

B TYPICAL BRACE FRAME DETAIL
S2.1 Scale: 3/4" = 1'-0"

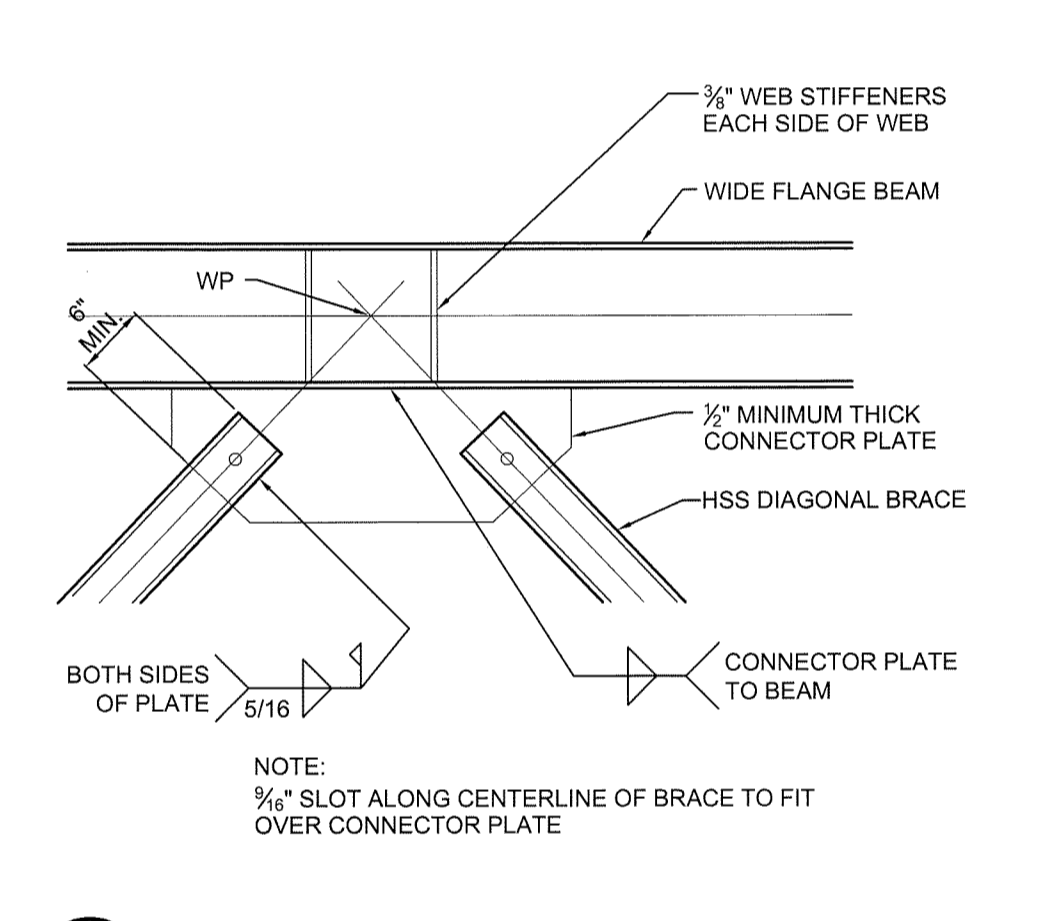

C TYPICAL BRACE FRAME DETAIL
S2.1 Scale: 3/4" = 1'-0"

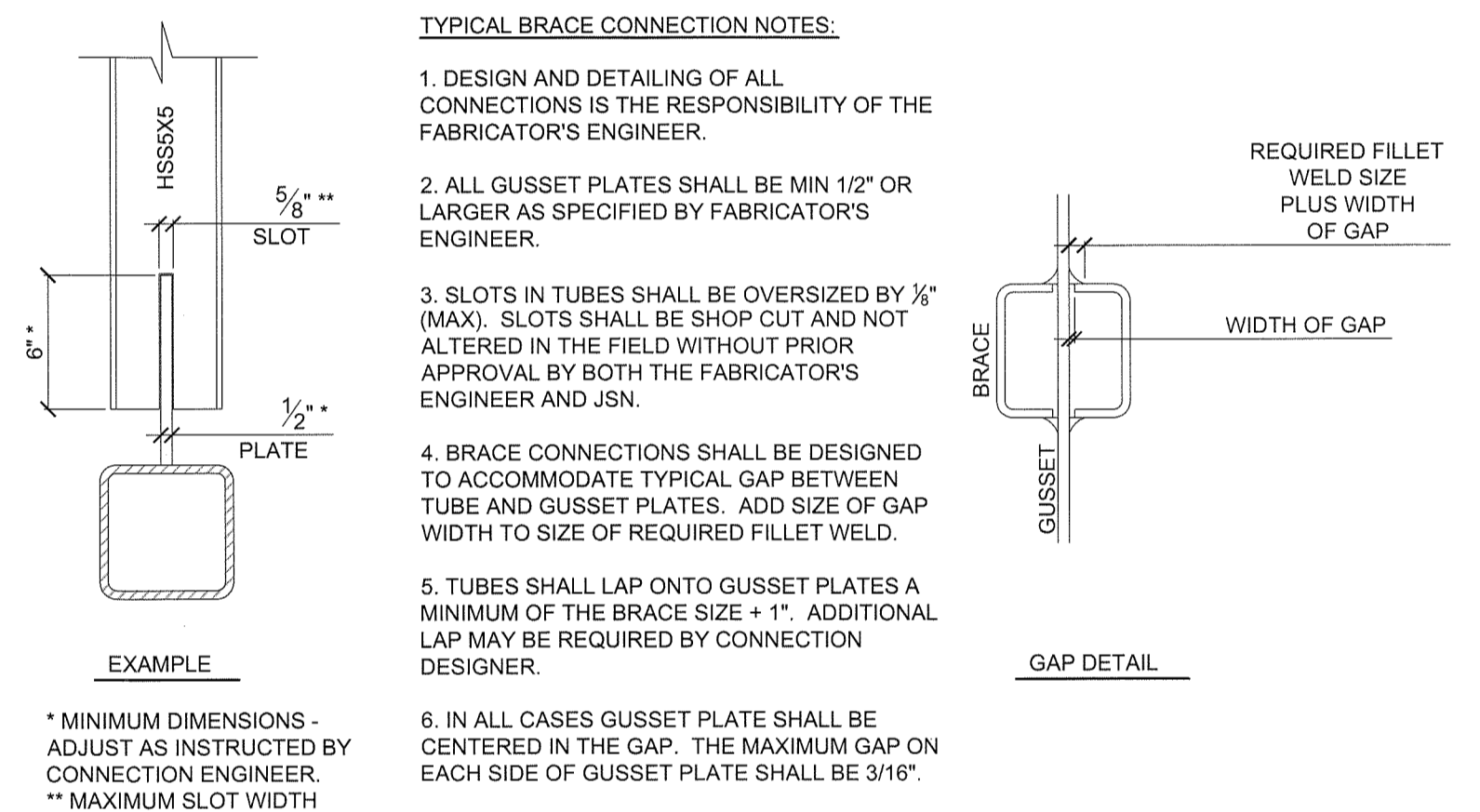

D BRACE CONNECTION DETAIL
S2.1 Scale: 3/4" = 1'-0"

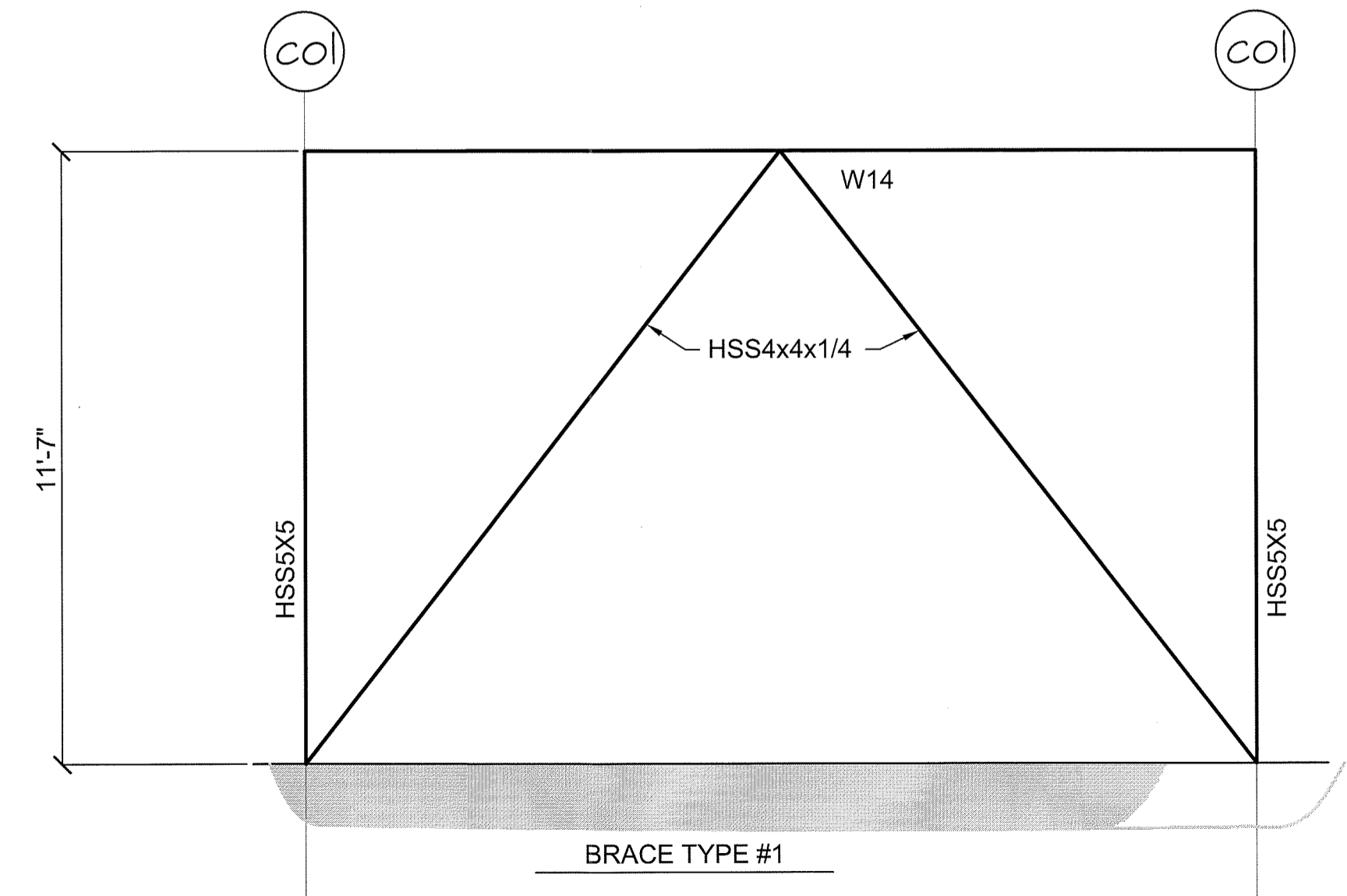

1 BRACED FRAME ELEVATIONS
S2.1 Scale: NOT TO SCALE

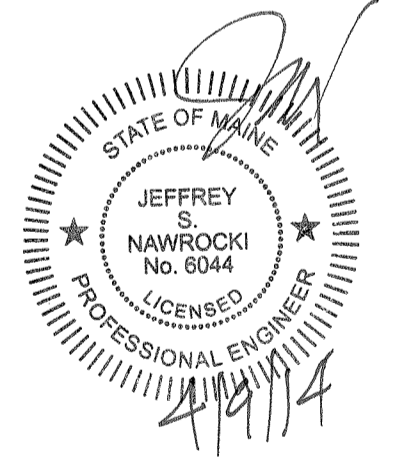

Date: 04/09/14
Scale: As Noted
By: JSN

Revisions

Framing Details

S2.1

Project No: 131015