

# FireWarden-100-2(E) Rev 3

## Intelligent Addressable FACP



Addressable Fire Alarm Control Panel

### General

The Notifier FireWarden-100-2 Rev 3 (NFW2-100) with Version 5.0 firmware is a combination FACP (Fire Alarm Control Panel) and DACT (Digital Alarm Communicator/Transmitter) all on one circuit board. This compact intelligent addressable control panel has an extensive list of powerful features.

The SLC (Signaling Line Circuit) of the FireWarden-100-2 Rev 3 operates using a Rapid Group Polling communication protocol technology that polls multiple devices simultaneously for a quicker device response time. This patented technology allows a fully-loaded panel with up to 198 devices to report an incident and activate the notification circuits in under 10 seconds. With this improved polling, devices can be wired on standard twisted, unshielded wire up to a distance of 10,000 feet.

The 's quick-remove chassis protects the electronics during construction. The backbox can be installed allowing field wiring to be pulled. When construction is completed, the electronics can be quickly installed with just two bolts.

**New features for Rev 3 with Version 5.0 firmware** include removable terminal blocks, improved transient protection, additional secondary ANN-BUS, and increased power for the resettable and remote sync outputs.

Available accessories include ANN-BUS devices as well as ACS LED, graphic and LCD annunciators, and reverse polarity/city box transmitter.

The integral DACT transmits system status (alarms, supervisories, troubles, AC loss, etc.) to a Central Station via the public switched telephone network. It also allows remote and local programming of the control panel using the PS-Tools Upload/Download utility. In addition, the control panel may be programmed or interrogated off-site via the public switched telephone network. Any personal computer with Windows® XP or greater, a compatible modem, and PS-Tools—the Upload/Download software kit—may serve as a Service Terminal. This allows download of the entire program or upload of the entire program, history file, walktest data, current status and system voltages. The panel can also be programmed through the FACP's keypad or via a standard PS-2 computer keyboard, which can be plugged directly into the printed circuit board. This permits easy typing of address labels and other programming information.

Version 5.0 firmware supports the following: Primary and Secondary ANN-bus devices, NP-A100, USB port, NAC circuit diagnostics, a new report has been added to the walk-test that lists untested devices, new device types added: audio telephone type code for NFV-25/50ZST, Photo Supervisory and auto-resettable Drill (non-latching).

The FireWatch Series internet monitoring modules IPDACT-2 and IPDACT-2UD permit monitoring of alarm signals over the Internet saving the monthly cost of two dedicated business telephone lines. Although not required, the secondary telephone line may be retained providing backup communication over the public switched telephone line.

**NOTE:** Unless otherwise specified, the term "FireWarden-100-2" is used in this document to refer to both the FireWarden-100-2 and the FireWarden-100-2E FACP's (Fire Alarm Control Panels). Likewise, "NFW2-100" refers to NFW2-100E as well.

### Features

- Listed to UL standard 864, 9th edition.
- On-board DACT.

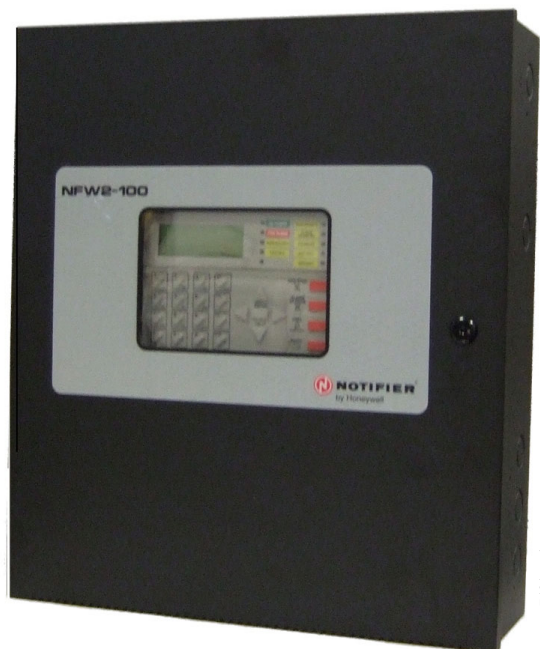

- Remote site or local USB port upload/download, using PS-Tools.
- Four (4) Style Y (Class B) NAC circuits, which can be converted to four (4) Style Z (Class A) circuits with optional ZNAC-92 converter module. (Up to 6.0 amps total NAC power when using optional XRM-24B.)
- Selectable strobe synchronization for System Sensor, Wheelock, and Gentex devices.
- Remote Acknowledge, Silence, Reset and Drill via addressable monitor modules or FDU-80, N-ANN-80 or Legacy ACS Annunciators.
- ANN-BUS for connection to following optional modules (cannot be used if ACS annunciators are used):
  - N-ANN-80(-W) Remote LCD Annunciator
  - N-ANN-I/O LED Driver
  - N-ANN-S/PG Printer Module
  - N-ANN-RLY Relay Module
  - N-ANN-LED Annunciator Module
  - N-ANN-RLED Annunciator Module alarms only
  - ROME Relay Option Module Enclosure
- ACS & Terminal-mode Annunciators:
  - ACS Annunciators: Up to 32 Legacy ACM Series annunciators (ACM-16AT or ACM-32 series). Cannot be used if ANN-BUS devices are used.
  - Terminal-mode Annunciators: Up to 32 Legacy FDU-80 annunciators.
- EIA-232 printer/PC interface (variable baud rate) on main circuit board, for use with optional UL-listed printer PRN-6.
- Integral 80-character LCD display with backlighting.
- Real-time clock/calendar with automatic daylight savings control.
- Detector sensitivity test capability (NFPA 72 compliant).

- History file with 1,000-event capacity.
- Maintenance alert warns when smoke detector dust accumulation is excessive.
- Automatic device type-code verification.
- One person audible or silent walk test with walk-test log and printout.
- Point trouble identification.
- Waterflow (nonsilenceable) selection per monitor point.
- System alarm verification selection per detector point.
- PAS (Positive Alarm Sequence) and presignal delay per point (NFPA 72 compliant).

**NOTE:** Only detectors may participate in PAS.

#### **SLC LOOP:**

- SLC can be configured for NFPA Style 4, 6, or 7 operation.
- SLC supports up to 198 addressable devices per loop (99 detectors and 99 monitor, control, or relay modules).
- SLC loop maximum length 10,000 ft. (3,000 m.).  
*See installation manual for wire tables.*

#### **NOTIFICATION APPLIANCE CIRCUITS (NACS):**

- Four onboard NACs with additional NAC capability using output control modules (NC-100). The four Class B NACs can be converted to four Class A NACs with optional ZNAC-92 converter module.
- Silence Inhibit and Auto Silence timer options.
- Continuous, March Time, Temporal or California code for main circuit board NACs with two-stage capability.
- Selectable strobe synchronization per NAC.
- 2.5 amps maximum per each NAC circuit.

**NOTE:** Maximum 24VDC system power output is shared among all NAC circuits and 24VDC special-application auxiliary power outputs. Total available output is 3.0 amps. Using the optional XRM-24B transformer increases 24VDC output to 6.0 amps.

#### **PROGRAMMING AND SOFTWARE:**

- Autoprogram (learn mode) reduces installation time.
- Custom English labels (per point) may be manually entered or selected from an internal library file.
- Three Form-C relay outputs (two programmable).
- 99 software zones.
- Continuous fire protection during online programming at the front panel.
- Program Check automatically catches common errors not linked to any zone or input point.
- **OFFLINE PROGRAMMING:** Create the entire program in your office using a Windows®-based software package (NFW2-100 requires PS-Tools Programming software, available on [www.magni-fire.com](http://www.magni-fire.com)). Upload/download system programming locally to the NFW2-100 Rev 3 in less than one minute.
- USB upload/download programming with standard Male-A to Male-B cable.

## **User Interface**

#### **LED INDICATORS**

- AC Power (green)
- Fire Alarm (red)
- Supervisory (yellow)
- Alarm Silenced (yellow)
- System Trouble (yellow)
- Maintenance/Presignal (yellow)
- Disabled (yellow)
- Battery Fault (yellow)

- Ground Fault (yellow)

#### **KEYPAD CONTROLS**

- Acknowledge/Step
- Alarm Silence
- Drill
- System Reset (lamp test)
- 16-key alpha-numeric pad (similar to telephone keypad)
- 4 cursor keys
- Enter

## **Product Line Information**

**NFW2-100:** FireWarden-100-2 Rev 3 198-point addressable Fire Alarm Control Panel, one SLC loop. Includes 80-character LCD display, single printed circuit board mounted on chassis, and cabinet. 120 VAC operation.

**NFW2-100R:** Same as **NFW2-100**, except in a red backbox.

**NFW2-100E:** Same as **NFW2-100**, except with 240 VAC operation.

**4XTM Reverse Polarity Transmitter Module:** Provides supervised output for local energy municipal box transmitter, alarm, and trouble.

**ZNAC-92:** Optional converter module which converts four (4) Style Y (Class B) NAC circuits to four (4) Style Z (Class A) circuits.

**PS Tools:** Programming software for Windows®-based PC computer (cable not included), available on [www.firelite.com](http://www.firelite.com).

**DP-9692B:** Optional dress panel for FireWarden-100-2 Rev 3.

**TR-CE-B:** Optional trim Ring for semi-flush mounting.

**BB-26:** Battery backbox, holds up to two 26 AH batteries and CHG-75.

**NFS-LBB:** Battery box, houses two 55 AH batteries.

**CHG-75:** Battery charger for lead-acid batteries with a rating of 25 to 75 AH.

**CHG-120:** Remote battery charging system for lead-acid batteries with a rating of 55 to 120 AH. Requires additional NFS-LBB for mounting.

**NOTE:** CHG-120 or CHG-75 required for batteries larger than 18AH.

**BAT Series:** Batteries, see data sheet DN-6933.

**XRM-24B(E):** Optional transformer. Increases system power output to 6.0 amps. Use XRM-24BE with FireWarden-100-2E Rev 3.

**PRT/PK-CABLE:** Cable printer/personal computer interface cable; required for printer or for local upload/download programming and updating panel firmware.

**PRN-6:** UL listed compatible event printer. Uses tractor-fed paper.

**IPDACT-2/2UD, IPDACT Internet Monitoring Module:** Mounts in bottom of enclosure with optional mounting kit (PN IPBRKT). Connects to primary and secondary DACT telephone output ports for internet communications over customer provided ethernet internet connection. Requires compatible Teldat VisorALARM Central Station Receiver. Can use DHCP or static IP. (*See data sheet DN-60408 for more information.*)

**IPBRKT:** Mounting kit for IPDACT-2/2UD in common enclosure.

**IPSPLT:** Y-adaptor option allows connection of both panel dialer outputs to one IPDACT-2/2UD cable input.

#### **COMPATIBLE ANNUNCIATORS**

**N-ANN-80(-W):** LCD Annunciator is a remote LCD annunciator that mimics the information displayed on the FACP LCD display. Recommended wire type is un-shielded. (Basic model is black; order -W version for white; see DN-7114.)

**N-ANN-LED:** Annunciator Module provides three LEDs for each zone: Alarm, Trouble and Supervisory. Ships with red or black enclosure (see DN-60242).

**N-ANN-RLED:** Provides alarm (red) indicators for up to 30 input zones or addressable points. (See DN-60242).

**N-ANN-RLY:** Relay Module, which can be mounted inside the cabinet, provides 10 programmable Form-C relays. (See DN-7107.)

**ROME-B:** Relay Option Module Enclosure (order ROME-B for black or ROME for red). Provides one **N-ANN-RLY** Relay Module already installed. The ROME Series provides mounting space for one additional Relay Module or one addressable Multi-module. (See *Installation Sheet PN 53530*.)

**N-ANN-S/PG:** Serial/Parallel Printer Gateway module provides a connection for a serial or parallel printer. (See DN-7103.)

**N-ANN-I/O:** LED Driver Module provides connections to a user supplied graphic annunciator. (See DN-7105.)

**ACM-8R:** Relay module provides 8 Form-C 5.0 amp relays.

**ACM Annunciator Series:** LED-type fire annunciators capable of providing up to 99 software zones of annunciation. Available in increments of 16 or 32 points to meet a variety of applications.

**LDM Graphic Series:** Lamp Driver Module series for use with custom graphic annunciators.

**FDU-80 (Liquid Crystal Display) point annunciator:** 80-character, backlit LCD-type fire annunciators capable of displaying English-language text.

**NOTE:** For more information on Compatible Annunciators for use with the FireWarden-100-2 Rev 3, see the following data sheets (document numbers) ACM-8R (DN-3558), ACS/ACM Series (DN-0524), LDM Series (DN-0551), FDU-80 (DN-6820).

### COMPATIBLE ADDRESSABLE DEVICES

All feature a polling LED and rotary switches for addressing.

**NI-100:** Addressable low-profile ionization smoke detector.

**NP-100:** Addressable low-profile photoelectric smoke detector.

**NP-100T:** Addressable low-profile photoelectric smoke detector with thermal sensor.

**NP-100R:** Addressable remote test capable detector for use with DNR(W) duct smoke detector housings.

**NH-100:** Fast-response, low-profile heat detector.

**NH-100R:** Fast-response, low-profile heat detector with rate-of-rise option.

**NH-100H:** Fixed high-temperature detector that activates at 190F/88C.

**NP-A100:** Addressable low-profile multi-sensor detector.

**DNR:** Innovair Flex low-flow non-relay duct-detector housing. Order NP-100R separately.

**DNRW:** Innovair Flex low-flow non-relay duct-detector housing, with NEMA-4 rating. Watertight. (Order NP-100R separately.)

**NMM-100:** Addressable Monitor Module for one zone of normally-open dry-contact initiating devices. Mounts in standard 4.0" (10.16 cm.) box. Includes plastic cover plate and end-of-line resistor. Module may be configured for either a Style B (Class B) or Style D (Class A) IDC.

**NDM-100:** Dual Monitor Module. Same as NMM-100 except it provides two Style B (Class B) only IDCs.

**NMM-100P:** Miniature version of NMM-100. Excludes LED and Style D option. Connects with wire pigtailed. May mount in device backbox.

**NZM-100:** Similar to NMM-100, but may monitor up to 20 conventional two-wire detectors. Requires resettable 24 VDC power. Consult factory for compatible smoke detectors.

**NC-100:** Addressable Control Module for one Style Y/Z (Class B/A) zone of supervised polarized Notification Appliances. Mounts directly to a 4.0" (10.16 cm.) electrical box. Notification

Appliance Circuit option requires external 24 VDC to power notification appliances.

**NC-100R:** Addressable relay module containing two isolated sets of Form-C contacts, which operate as a DPDT switch. Mounts directly to a 4.0" (10.16 cm.) box, surface mount using the SMB500.

**NOT-BG12LX:** Addressable manual pull station with interface module mounted inside.

**N100-ISO:** Fault Isolator Module. This module isolates the SLC loop from short circuit conditions (required for Style 6 or 7 operation).

**SMB500:** Used to mount all modules except the NMM-100P.

**NMM-100-10:** Ten-input monitor module. Mount one or two modules in a BB-XP cabinet (optional). Mount up to six modules on a CHS-6 chassis in a BB-25.

**NZM-100-6:** Six-zone interface module for compatible conventional two-wire detectors. Mount one or two modules in a BB-XP cabinet (optional). Mount up to six modules on a CHS-6 chassis in a BB-25.

**NOTE:** For more information on Compatible Addressable Devices for use with the FireWarden-100-2 Rev 3, see the following data sheets (document numbers): N100-ISO (DN-6994), NP-100 series (DN-6995), NI-100 (DN-6996), NH-100 series (DN-6997), ND-100 series (DN-7006), NP-A100 (DN-6998), NMM-100/NMM-100P/NDM-100/NZM-100 (DN-6999), NC-100/NC-100R (DN-7000), NOT-BG12LX (DN-7001), NMM-100-10 (DN-6990), and NZM-100-6 (DN-60150).

### Wiring Requirements

While shielded wire is not required, it is recommended that all SLC wiring be twisted-pair to minimize the effects of electrical interference. Wire size should be no smaller than 18 AWG (0.78 mm<sup>2</sup>) and no larger than 12 AWG (3.1 mm<sup>2</sup>). The wire size depends on the length of the SLC circuit. Refer to the panel manual for wiring details.

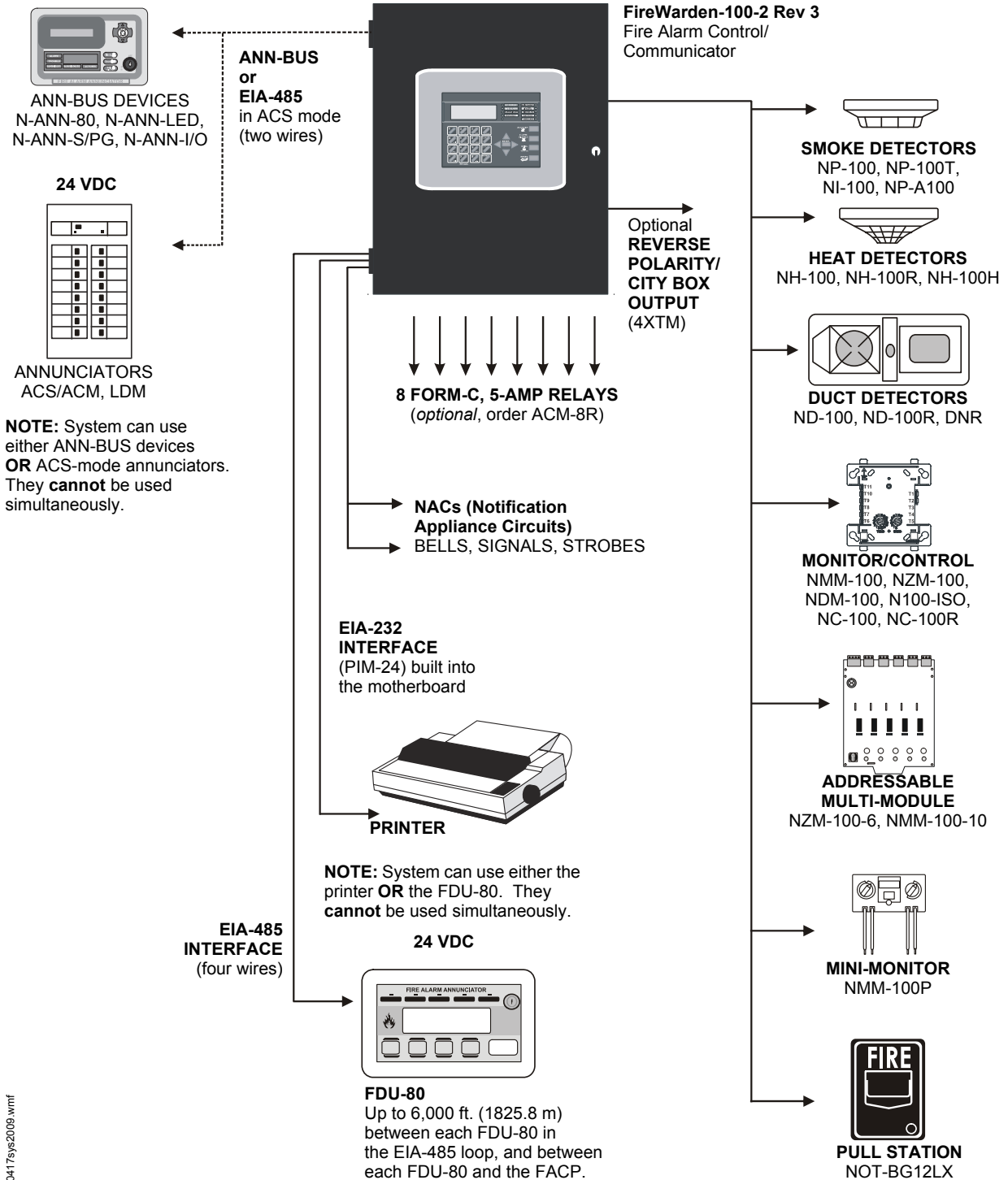

60417sys2009.wmf



# SYSTEM SPECIFICATIONS

## System Capacity

- Intelligent Signalling Line Circuits..... 1
- Addressable device capacity ..... 198
- Programmable software zones ..... 99
- ACS Annunciators ..... 32
- ANN-bus devices ..... 16

## Electrical Specifications

**AC Power:** FireWarden-100-2 Rev 3: 120 VAC, 60 Hz, 3.0 amps. FireWarden-100-2 Rev 3(E): 240 VAC, 50 Hz, 1.5 amps. Wire size: minimum 14 AWG (2.00 mm<sup>2</sup>) with 600 V insulation.

**Battery charger capacity:** 7 AH - 18 AH batteries. Up to two 18 Ah batteries can be housed in the FACP cabinet. Larger batteries require an external battery charger such as the CHG-75 or CHG-120, and a separate battery cabinet such as the BB-26 or NFS-LBB.

**Communication Loop:** Supervised and power-limited.

**Notification Appliance Circuits:** Each terminal block provides connections for two Style Y (Class B) for a total of four Style Y (Class B) or with an optional ZNAC-92 module converts to four Style Z (Class A) NACs. Maximum signaling current per circuit: 2.5 amps. End-of-Line Resistor: 4.7K ohm, 1/2 watt (P/N 71252 UL listed) for Style Y (Class B) NAC. Refer to panel documentation and *Notifier Device Compatibility Document* for listed compatible devices.

**Two Programmable Relays and One Fixed Trouble Relay:** Contact rating: 2.0 amps @ 30 VDC (resistive), 0.5 amps @ 30 VAC (resistive). Form-C relays.

**Special Application Non-resettable Power (24 VDC Nominal):** Jumper selectable (JP4) for conversion to resettable power output. Up to 1.0 amp total DC current available from each output. Power-limited.

**Special Application Resettable Power (24 VDC nominal):** Jumper selectable (JP6) for conversion to non-resettable power. Up to 1.0 amp total DC current available. Refer to the *Notifier Device Compatibility Document* for listed compatible devices.

**Remote Sync Output:** Remote power supply synchronization output. Nominal special application power: 24 VDC. Maximum current: 300 mA. End-of-Line Resistor: 4.7K ohm. Output linked to NAC 1 control. Supervised and power-limited.

**Telephone Interface:** Unless used with Teldat VISORALARM, requires dedicated business telephone number with a minimum of 5 volts DC (off-hook voltage). Obtain dedicated phone line directly from your local phone company. Do not use shared phone lines or PBX (digital) type phone line extensions.

## Cabinet Specifications

**Door:** 19.26" (48.92 cm.) high x 16.82" (42.73 cm.) wide x 0.12" (.30 cm.) deep. **Backbox:** 19.00" (48.26 cm.) high x 16.65"

(42.29 cm.) wide x 5.20" (13.34 cm.) deep. **Trim Ring (TR-CE-B):** 22.00" (55.88 cm.) high x 19.65" (49.91 cm.) wide.

## Shipping Specifications

**Weight:** 26.9 lbs. (12.20 kg.) **Dimensions:** 20.00" (50.80 cm.) high x 22.5" (57.15 cm.) wide x 8.5" (21.59 cm.) deep.

## Temperature and Humidity Ranges

This system meets NFPA requirements for operation at 0 – 49°C/32 – 120°F and at a relative humidity 93% ± 2% RH (non-condensing) at 32°C ± 2°C (90°F ± 3°F). However, the useful life of the system's standby batteries and the electronic components may be adversely affected by extreme temperature ranges and humidity. Therefore, it is recommended that this system and its peripherals be installed in an environment with a normal room temperature of 15 – 27°C/60 – 80°F.

## NFPA Standards

The FireWarden-100-2 Rev 3 complies with the following NFPA 72 Fire Alarm Systems requirements:

- **LOCAL** (Automatic, Manual, Waterflow and Sprinkler Supervisory).
- **AUXILIARY** (Automatic, Manual and Waterflow) (requires 4XTM).
- **REMOTE STATION** (Automatic, Manual, Waterflow and Sprinkler Supervisory) (Where a DACT is not accepted, the alarm, trouble and supervisory relays may be connected to UL 864 listed transmitters. For reverse polarity signaling of alarm and trouble, 4XTM is required.)
- **PROPRIETARY** (Automatic, Manual, Waterflow and Sprinkler Supervisory).
- **CENTRAL STATION** (Automatic, Manual, Waterflow and Sprinkler Supervisory).
- **OT, PSDN** (Other Technologies, Packet-switched Data Network)

## Agency Listings and Approvals

The listings and approvals below apply to the basic FireWarden-100-2 Rev 3 control panel. In some cases, certain modules may not be listed by certain approval agencies, or listing may be in process. Consult factory for latest listing status.

- **UL Listed:** S635
- **FM approved**
- **CSFM:** 7165-0028:0235
- **MEA:** 120-06-E, Volume 2

For ULC-listed version, see DN-60600.

NOTIFIER® is a registered trademark of Honeywell International Inc. Wheelock® is a registered trademark of and Exceder™ is a trademark of Cooper Notification.

©2010 by Honeywell International Inc. All rights reserved. Unauthorized use of this document is strictly prohibited.



This document is not intended to be used for installation purposes. We try to keep our product information up-to-date and accurate. We cannot cover all specific applications or anticipate all requirements. All specifications are subject to change without notice.



Made in the U.S. A.

For more information, contact Notifier. Phone: (203) 484-7161, FAX: (203) 484-7118.  
www.notifier.com

# BAT Series Batteries

## Sealed Lead-Acid or Gell Cell

**Power Supplies**

### General

**BAT Series Batteries** feature a new part-numbering/listing system — providing an improved method of delivery for NOTIFIER-approved sealed lead-acid batteries for all your fire alarm system needs. Multiple brands of batteries are now offered under generic part numbers, reducing backorder situations and permitting us to deliver these products in a more timely fashion. NOTIFIER has approved the multiple brands listed below as possible product shipped for a given part number. Please note that any incoming orders for “PS Series” batteries will be converted to the equivalent BAT Series part numbers.



6933cov.jpg

### Features

- Provide secondary power for control panels.
- Sealed and maintenance-free.
- Overcharge protected.
- Easy handling with leakproof construction.
- Ruggedly constructed, high-impact case (ABS, polystyrene, or polypropylene, depending on models).
- Long service life.
- Compact design.

### Agency Listings and Approvals

The listings and approvals below apply to BAT Series Batteries. In some cases, certain modules may not be listed by certain approval agencies, or listing may be in process. Consult factory for latest listing status.

- **UL Recognized Components:** files MH19884 (*B & B Battery*), MH20567 (*UPG, previously Jolt*), MH20845 (*Power-Sonic*).

### Part Number Reference

CURRENT Part Number	BATTERY DESCRIPTION	ALTERNATES APPROVED: manufacturers and P/Ns shipped under BAT P/Ns
BAT-1250	12 V, 5 AH, sealed.	BP5-12 (B&B Battery); PS-1250 (Power-Sonic); SA1250 (Jolt) to be replaced with UB1250 (UPG).
BAT-1250	12 V, 5 AH, sealed.	BP5-12 (B&B Battery); PS-1250 (Power-Sonic); SA1250 (Jolt) to be replaced with UB1250 (UPG).
BAT-1270	12 V, 7 AH, sealed.	BP7-12 (B&B Battery); PS-1270 (Power-Sonic); SA1272 (Jolt) to be replaced with UB1270 (UPG).
BAT-12120	12 V, 12 AH, sealed.	BP12-12 (B&B Battery); PS-12120 (Power-Sonic); SA12120 (Jolt) to be replaced with UB12120 (UPG).
BAT-12180	12 V, 18 AH, sealed.	PS-12180 (Power-Sonic); SA12180 (Jolt) to be replaced with UB12180 (UPG).
BAT-12180	12 V, 18 AH, sealed.	PS-12180 (Power-Sonic); SA12180 (Jolt) to be replaced with UB12180 (UPG).
BAT-12260	12 V, 26 AH, sealed.	BP26-12 (B&B Battery); PS-12260 (Power-Sonic); SA12260 (Jolt) to be replaced with UB12260 (UPG).
BAT-12550	12 V, 55 AH, sealed.	PS-12550 (Power-Sonic); XSA12550 (Jolt) to be replaced with UB12550 (UPG).
BAT-12550	12 V, 55 AH, sealed.	PS-12550 (Power-Sonic); XSA12550 (Jolt) to be replaced with UB12550 (UPG).
BAT-121000	12 V, 100 AH, gell cell.	PS-121000 (Power-Sonic); XSA121000A (Jolt) to be replaced with UB121000 (UPG).

# POWER-SONIC

## Part Number Reference

1109t1.tbl

MODEL	Nominal Voltage V	Nominal Capacity @ 20 hr. rate A.H.	Discharge Current @20 hr. rate mA	DIMENSIONS									
				Width		Depth		Height		Height over terminal		Weight	
				in.	mm	in.	mm	in.	mm	in.	mm	lb.	kg.
PS-1250	12	5	250	3.54	90	2.76	70	4.02	102	4.21	107	4.1	1.9
PS-1270	12	7	325	5.94	151	2.56	65	3.7	94	3.86	98	5.7	2.6
PS-12120	12	12	600	5.94	151	3.86	98	3.7	94	3.86	98	8.8	4
PS-12180	12	18	875	7.13	181	2.99	76	6.57	167	6.57	167	12.8	5.8
PS-12250	12	25	1300	6.89	175	6.54	166	4.92	125	4.92	125	18.7	8.5
PS-12550	12	55	3000	10.25	260	6.6	168	8.2	208	9.45	240	39.7	18
PS-121000	12	100	5000	12	305	6.6	168	8.2	208	9.45	240	65.7	29.8

**Characteristic Discharge Curves**

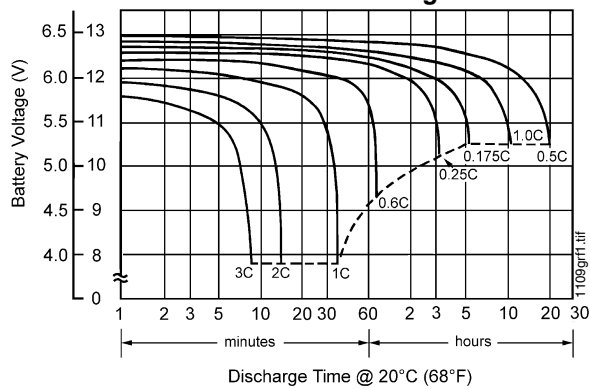

**Effect of Temperature on Capacity**

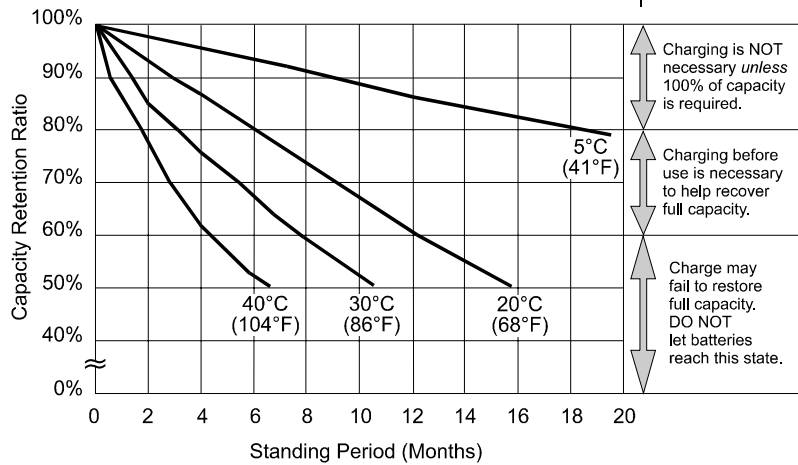
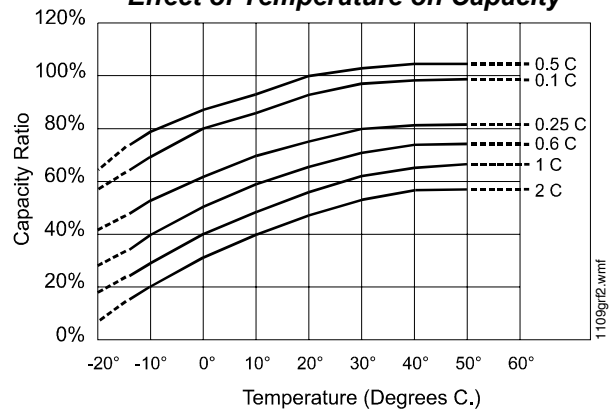

**at left:  
PS-121000  
Shelf-Life  
and Storage**

Charging is NOT necessary unless 100% of capacity is required.

Charging before use is necessary to help recover full capacity.

Charge may fail to restore full capacity. DO NOT let batteries reach this state.

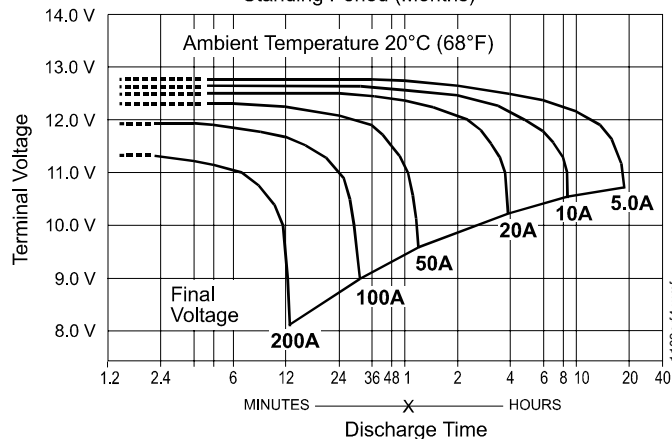

**at left:  
PS-121000  
Discharge  
Characteristics**



# NBG-12LX

## Addressable Manual Pull Station



Intelligent/Addressable Devices

### General

The Notifier NBG-12LX is a state-of-the-art, dual-action (i.e., requires two motions to activate the station) pull station that includes an addressable interface for any Notifier intelligent control panel except FireWarden series panels, and the NSP-25 panel. Because the NBG-12LX is addressable, the control panel can display the exact location of the activated manual station. This leads fire personnel quickly to the location of the alarm.

### Features

- Maintenance personnel can open station for inspection and address setting without causing an alarm condition.
- Built-in bicolor LED, which is visible through the handle of the station, flashes in normal operation and latches steady red when in alarm.
- Handle latches in down position and the word “ACTIVATED” appears to clearly indicate the station has been operated.
- Captive screw terminals wire-ready for easy connection to SLC loop (accepts up to 12 AWG/3.25 mm<sup>2</sup> wire).
- Can be surface mounted (with SB-10 or SB-I/O) or semi-flush mounted. Semi-flush mount to a standard single-gang, double-gang, or 4" (10.16 cm) square electrical box.
- Smooth dual-action design.
- Meets ADAAG controls and operating mechanisms guidelines (Section 4.1.3[13]); meets ADA requirement for 5 lb. maximum activation force.
- Highly visible.
- Attractive shape and textured finish.
- Key reset.
- Includes Braille text on station handle.
- Optional trim ring (BG12TR).
- Meets UL 38, Standard for Manually Actuated Signaling Boxes.
- Up to 99 NBG-12LX stations per loop on CLIP protocol loops.
- Up to 159 NBG-12LX stations per loop on FlashScan® protocol loops.
- Dual-color LED blinks green to indicate normal on FlashScan® systems.

### Construction

Shell, door, and handle are molded of durable polycarbonate material with a textured finish.

### Specifications

- **Shipping Weight:** 9.6 oz. (272.15 g)
- **Normal operating voltage:** 24 VDC.
- **Maximum SLC loop voltage:** 28.0 VDC.
- **Maximum SLC standby current:** 375  $\mu$ A.
- **Maximum SLC alarm current:** 5 mA.
- **Temperature Range:** 32°F to 120°F (0°C to 49°C)
- **Relative Humidity:** 10% to 93% (noncondensing)
- **For use indoors in a dry location**



The NBG-12LX  
Addressable Manual Pull Station

### Installation

The NBG-12LX will mount semi-flush into a single-gang, double-gang, or standard 4" (10.16 cm) square electrical outlet box, or will surface mount to the model SB-10 or SB-I/O surface backbox. If the NBG-12LX is being semi-flush mounted, then the optional trim ring (BG12TR) may be used. The BG12TR is usually needed for semi-flush mounting with 4" (10.16 cm) or double-gang boxes (not with single-gang boxes).

### Operation

Pushing in, then pulling down on the handle causes it to latch in the down/activated position. Once latched, the word “ACTIVATED” (in bright yellow) appears at the top of the handle, while a portion of the handle protrudes from the bottom of the station. To reset the station, simply unlock the station with the key and pull the door open. This action resets the handle; closing the door automatically resets the switch.

Each manual station, on command from the control panel, sends data to the panel representing the state of the manual switch. Two rotary decimal switches allow address settings (1 – 159 on FlashScan® systems, 1 – 99 on CLIP systems).

### Architectural/Engineering Specifications

Manual Fire Alarm Stations shall be non-coded, with a key-operated reset lock in order that they may be tested, and so designed that after actual Emergency Operation, they cannot be restored to normal except by use of a key. An operated station shall automatically condition itself so as to be visually detected as activated. Manual stations shall be constructed of red-colored polycarbonate material with clearly visible operating instructions provided on the cover. The word FIRE shall appear on the front of the stations in white letters, 1.00 inches (2.54 cm) or larger. Stations shall be suitable for surface mounting on matching backbox SB-10 or SB-I/O; or semi-flush mounting on a standard single-gang, double-gang, or

4" (10.16 cm) square electrical box, and shall be installed within the limits defined by the Americans with Disabilities Act (ADA) or per national/local requirements. Manual Stations shall be Underwriters Laboratories listed.

Manual stations shall connect with two wires to one of the control panel SLC loops. The manual station shall, on command from the control panel, send data to the panel representing the state of the manual switch. Manual stations shall provide address setting by use of rotary decimal switches.

The loop poll LED shall be clearly visible through the front of the station. The LED shall flash while in the normal condition, and stay steadily illuminated when in alarm.

## Product Line Information

**NBG-12LX:** Dual-action addressable pull station. Includes key locking feature. (Listed for Canadian and non-Canadian applications.)

**NBG-12LXSP:** Spanish/English labelled version.

**NBG-12LXP:** Portuguese labelled version.

**SB-10:** Surface backbox; metal.

**SB-I/O:** Surface backbox; plastic.

**BG12TR:** Optional trim ring.

**17021:** Keys, set of two.

**NY-Plate:** New York City trim plate.

## Agency Listings and Approvals

In some cases, certain modules or applications may not be listed by certain approval agencies, or listing may be in process. Consult factory for latest listing status.

- **UL/ULC Listed:** S692 (listed for Canadian and non-Canadian applications).
- **MEA:** 67-02-E.
- **CSFM:** 7150-0028:0199.
- **FDNY:** COA #6085 (NFS2-640), COA #6098 (NFS2-3030).
- **BSMI:** CI313066760047.
- **U.S. Coast Guard.**
- **Lloyd's Register.**
- **FM Approved.**

**Patented:** U.S. Patent No. D428,351; 6,380,846; 6,314,772; 6,632,108.

NOTIFIER® and FlashScan® are registered trademarks of Honeywell International Inc.

©2012 by Honeywell International Inc. All rights reserved. Unauthorized use of this document is strictly prohibited.



This document is not intended to be used for installation purposes.  
We try to keep our product information up-to-date and accurate.  
We cannot cover all specific applications or anticipate all requirements.  
All specifications are subject to change without notice.



Made in the U.S. A.

For more information, contact Notifier. Phone: (203) 484-7161, FAX: (203) 484-7118.  
[www.notifier.com](http://www.notifier.com)

# NP-100(A) Series

## Addressable Photoelectric Detectors for the FireWarden Series



Addressable

### General

The NP-100(A), NP-100T(A) and NP-100R(A) addressable, low-profile plug-in photoelectric detectors use a state-of-the-art photoelectric sensing chamber with communications to provide open area protection and are used exclusively with NOTIFIER's FireWarden Series (FireWarden-100-2 and FireWarden-50) and Spartan (NSP-25) Addressable Fire Alarm Control Panels (FACPs). The NP-100T(A) adds thermal sensors that will alarm at a fixed temperature of 135°F (57°C). Since these detectors are addressable, they will help emergency personnel quickly locate a fire during its early stages, potentially saving precious rescue time while also reducing property damage. Two LEDs on each sensor light to provide a local, visible sensor indication. Remote LED annunciator capability is available as an optional accessory, PN RA100Z(A). The NP-100R(A) is a remote test capable detector for use with DNR(A)/DNRW duct smoke detector housings.



NP-100(A) in B210LP(A) Base

B210-2851.jpg

### Features

#### SLC loop

- Two-wire loop connection.
- Unit uses base for wiring.

#### Addressing

- Addressable by device.
- Rotary, decimal addressing: 01 – 99 with FireWarden-100-2 and NSP-25, and 01 – 50 with FireWarden-50.

#### Architecture

- Unique single-source, dual-chamber design to respond quickly and dependably to a broad range of fires.
- Sleek, low-profile design.
- Integral communications and built-in type identification.
- Built-in tamper-resistant feature.
- Removable cover and insect-resistant screen for simple field cleaning.

#### Operation

- Withstands air velocities up to 4,000 feet-per-minute (20 m/sec.) without triggering a false alarm.
- Factory preset at 1.5% nominal sensitivity for panel alarm threshold level.
- Visible LED “blinks” when the unit is addressed (communicating with the fire panel) and latches on in alarm.

#### Mechanicals

- Sealed against back pressure.
- Direct surface mounting or electrical box mounting.
- Mounts to: single-gang box, 3.5" (8.89 cm) or 4.0" (10.16 cm) octagonal box, or 4.0" (10.16 cm) square electrical box (using a plaster ring — included).

#### Other system features

- Fully coated circuit boards and superior RF/transient protection.
- 94-V0 plastic flammability rating.
- Low standby current.

#### Options

- Remote LED output connection, PN RA100Z(A).

### Applications

Use photoelectric detectors in life-safety applications to provide a broad range of fire-sensing capability, especially where smoldering fires are anticipated. Ionization detectors are often better than photoelectric detectors at sensing fast, flaming fires.

### Construction

These detectors are constructed of off-white fire resistant plastic. NP-100(A) series plug-in, low-profile smoke detectors are designed to commercial standards and offer an attractive appearance.

### Installation

NP-100(A) series plug-in detectors use a detachable mounting base to simplify installation, service and maintenance.

Mount base (all base types) on an electrical backbox which is at least 1.5" (3.81 cm) deep. For a chart of compatible junction boxes, see DN-60054.

**NOTE:** Because of the inherent supervision provided by the SLC loop, end-of-line resistors are not required. Wiring “T-taps” or branches are permitted for Style 4 (Class B) wiring. NP-100R(A) mounts in a DNR(A)/DNRW duct detector housing.

### Operation

Each NP-100(A) series detector uses one of 99 possible addresses on the FireWarden-100-2 and NSP-25, or one of 50 possible addresses on the FireWarden-50 Signaling Line Circuit (SLC). It responds to regular polls from the system and reports its type and status.

The addressable photoelectric sensor in the NP-100(A) series has a unique unipolar chamber that responds quickly and uniformly to a broad range of smoke conditions. It can withstand wind gusts up to 4,000 feet-per-minute (20 m/sec.) without sending an alarm level signal. Because of its unipolar chamber, the NP-100(A) series is approximately two times more responsive than most photoelectric sensors. This makes it a more stable detector.

## Detector Sensitivity Test

Each detector can have its sensitivity tested (required per NFPA 72, Chapter 14 on *Inspection, Testing and Maintenance*) when installed/connected to a FireWarden-100-2 or FireWarden-50 addressable fire alarm control panel. The results of the sensitivity test can be printed off the FireWarden-100-2 or FireWarden-50 for record keeping.

## Specification

**Voltage range:** 15 – 32 VDC (peak).

**Standby current:** 300 µA @ 24 VDC.

**LED current:** 6.5 mA @ 24 VDC (latched "ON").

**Air velocity:** 4,000 ft./min. (20 m/sec.) maximum.

**Size:** 2.1" (5.33 cm) high; base determines diameter.

- **B210LP(A):** 6.1" (15.5 cm) diameter.
- **B501(A):** 4.1" (10.4 cm) diameter.
- **B200SR(A):** 6.875" (17.46 cm) diameter.
- **B224RB(A):** 6.2" (15.748 cm) diameter.

**Weight:** 3.6 oz. (102 g).

**Operating temperature range:** for **NP-100(A):** 0°C to 49°C (32°F to 120°F); for **NP-100T(A):** 0°C to 38°C (32°F to 100°F). **NP-100R(A):** installed in a DNR(A)/DNRW -20°C to 70°C (-4°F to 158°F).

**Temperature:** 0°C – 49°C (32°F – 120°F).

**Relative humidity:** 10% – 93%, non-condensing.

## Listings

Listings and approvals below apply to the NP-100(A), NP-100T(A), and NP-100R(A) detectors. In some cases, certain modules may not be listed by certain approval agencies, or listing may be in process. Consult factory for latest listing status.

- **UL Listed:** S1115.
- **ULC Listed:** S911.
- **CSFM:** 7272-0028:0231.
- **MEA:** 243-02-E Vol. 2.
- **Maryland State Fire Marshal:** permit 2173.
- **FM approved.**

## Product Line Information

**NOTE:** "A" suffix indicates ULC Listed model.

**NP-100:** Addressable photoelectric detector; B210LP base included.

**NP-100A:** Same as NP-100 with ULC Listing; B210LPA base included.

**NP-100T:** Same as NP-100 but with **thermal** element; B210LP base included.

**NP-100TA:** Same as NP-100T with ULC Listing; B210LPA base included.

**NP-100R:** Remote test capable addressable photoelectric detector for use with a DNRA/DNRW duct detector housing; B210LP base included.

**NP-100RA:** Same as NP-100R with ULC Listing for use with a DNRA duct detector housing; B210LPA base included.

## INTELLIGENT BASES

**NOTE:** "A" suffix indicates ULC Listed model.

**NOTE:** For details about intelligent bases and their mounting, see DN-60054.

**B210LP(A):** Plug-in detector base (included); standard U.S. flanged low-profile mounting base.

**B210LPBP:** Bulk pack of B210LP; package contains 10.

**B501(A):** Standard European flangeless mounting base.

**B501BP:** Bulk pack of B501; package contains 10.

**B200SR(A):** Intelligent sounder base capable of producing sound output with ANSI Temporal 3 or continuous tone. Replaces B501BH series bases in retrofit applications.

**B224RB(A):** Plug-in System Sensor **relay** base. Screw terminals: up to 14 AWG (2.0 mm<sup>2</sup>). Relay type: Form-C. Rating: 2.0 A @ 30 VDC resistive; 0.3 A @ 110 VDC inductive; 1.0 A @ 30 VDC inductive.

**B224BI(A):** Plug-in System Sensor **isolator** detector base. Maximum 25 devices between isolator bases (see DN-6994).

## ACCESSORIES

**F110:** Retrofit flange to convert B210LP(A) to match the B710LP(A) profile, or to convert older high-profile bases to low-profile.

**F110BP:** Bulk pack of F110; package contains 15.

**F210:** Replacement flange for B210LP(A) base.

**RA100Z(A):** Remote LED annunciator. 3 – 32 VDC. Mounts to a U.S. single-gang electrical box. For use with B501(A) and B210LP(A) bases only.

**SMB600:** Surface mounting kit

**M02-04-00:** Test magnet.

**M02-09-00:** Test magnet with telescoping handle.

**XR2B:** Detector removal tool. Allows installation and/or removal of detector heads from bases in high ceiling applications.

**XP-4:** Extension pole for XR2B. Comes in three 5-foot (1.524 m) sections.

**T55-127-010:** Detector removal tool without pole.

**BCK-200B:** Black detector covers for use with NP-100(A) only; box of 10.

**WCK-200B:** White detector covers for use with NP-100(A) only; box of 10.

NOTIFIER® and FireWarden® are registered trademarks of Honeywell International Inc.  
©2011. All rights reserved. Unauthorized use of this document is strictly prohibited.



This document is not intended to be used for installation purposes.  
We try to keep our product information up-to-date and accurate.  
We cannot cover all specific applications or anticipate all requirements.  
All specifications are subject to change without notice.



Made in the U.S. A.

For more information, contact Notifier. Phone: (203) 484-7161, FAX: (203) 484-7118.  
www.notifier.com

# Monitor Modules

## NMM-100(A), NMM-100P(A), NZM-100(A), and NDM-100(A) for FireWarden Series Panels



Intelligent Addressable Devices

### General

Four different monitor modules are available for Notifier's FireWarden Series intelligent control panels for a variety of applications. Monitor modules supervise a circuit of dry-contact input devices, such as conventional heat detectors and pull stations, or monitor and power a circuit of two-wire smoke detectors (NZM-100(A)).

**NMM-100(A)** is a standard-sized module (typically mounts to a 4" [10.16 cm] square box) that supervises either a Style D (Class A) or Style B (Class B) circuit of dry-contact input devices.

**NMM-100P(A)** is a miniature monitor module a mere 1.3" (3.302 cm) H x 2.75" (6.985 cm) W x 0.5" (1.270 cm) D that supervises a Style B (Class B) circuit of dry-contact input devices. Its compact design allows the NMM-100P(A) to be mounted in a single-gang box behind the device it monitors.

**NZM-100(A)** is a standard-sized module that monitors and supervises compatible two-wire, 24 volt, smoke detectors on a Style D (Class A) or Style B (Class B) circuit.

**NDM-100(A)** is a standard-sized dual monitor module that monitors and supervises two independent two-wire Style B (Class B) dry-contact initiating device circuits (IDCs) at two separate, consecutive addresses in intelligent, two-wire systems.

### NMM-100(A) Monitor Module

- Built-in type identification automatically identifies this device as a monitor module to the control panel.
- Powered directly by two-wire SLC loop. No additional power required.
- High noise (EMF/RFI) immunity.
- SEMS screws with clamping plates for ease of wiring.
- Direct Decade entry of address: 01 – 99 on FireWarden-100-2, 01 – 50 on FireWarden-50.
- LED flashes during normal operation and latches on steady to indicate alarm.

The NMM-100(A) Monitor Module is intended for use in intelligent, two-wire systems, where the individual address of each module is selected using the built-in rotary switches. It provides either a two-wire or four-wire fault-tolerant Initiating Device Circuit (IDC) for normally-open-contact fire alarm and supervisory devices. The module has a panel-controlled LED indicator.

### NMM-100(A) APPLICATIONS

Use to monitor a zone of four-wire smoke detectors, manual fire alarm pull stations, waterflow devices, or other normally-open dry-contact alarm activation devices. May also be used to monitor normally-open supervisory devices with special supervisory indication at the control panel. Monitored circuit may be wired as an NFPA Style B (Class B) or Style D (Class A) Initiating Device Circuit. A 47K ohm End-of-Line Resistor (provided) terminates the Style B circuit. No resistor is required for supervision of the Style D circuit.



NMM-100(A) (Type H)

### NMM-100(A) OPERATION

Each NMM-100(A) uses one of the available module addresses on an SLC loop. It responds to regular polls from the control panel and reports its type and the status (open/normal/short) of its Initiating Device Circuit (IDC). A flashing LED indicates that the module is in communication with the control panel. The LED latches steady on alarm (subject to current limitations on the loop).

### NMM-100(A) SPECIFICATIONS

**Nominal operating voltage:** 15 to 32 VDC.

**Maximum current draw:** 5.0 mA (LED on).

**Average operating current:** 350  $\mu$ A (LED flashing), 1 communication every 5 seconds, 47k EOL.

**Maximum IDC wiring resistance:** 40 ohms.

**EOL resistance:** 47K ohms.

**Temperature range:** 32°F to 120°F (0°C to 49°C).

**Humidity range:** 10% to 93% noncondensing.

**Dimensions:** 4.5" (11.43 cm) high x 4" (10.16 cm) wide x 1.25" (3.175 cm) deep. Mounts to a 4" (10.16 cm) square x 2.125" (5.398 cm) deep box.

## NMM-100P(A) Mini Monitor Module

- Built-in type identification automatically identifies this device as a monitor module to the panel.
- Powered directly by two-wire SLC loop. No additional power required.
- High noise (EMF/RFI) immunity.
- Tinned, stripped leads for ease of wiring.
- Direct Decade entry of address: 01 – 99 on FireWarden-100-2, 01 – 50 on FireWarden-50.

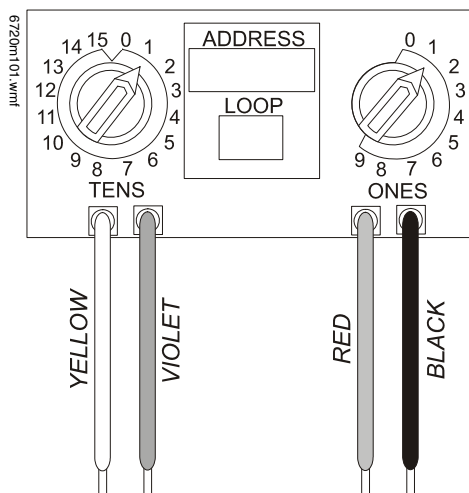

The NMM-100P(A) Mini Monitor Module can be installed in a single-gang junction directly behind the monitored unit. Its small size and light weight allow it to be installed without rigid mounting. The NMM-100P(A) is intended for use in intelligent, two-wire systems where the individual address of each module is selected using rotary switches. It provides a two-wire initiating device circuit for normally-open-contact fire alarm and security devices. NMM-100P(A)

### NMM-100P(A) APPLICATIONS

Use to monitor a single device or a zone of four-wire smoke detectors, manual fire alarm pull stations, waterflow devices, or other normally-open dry-contact devices. May also be used to monitor normally-open supervisory devices with special supervisory indication at the control panel. Monitored circuit/device is wired as an NFPA Style B (Class B) Initiating Device Circuit. A 47K ohm End-of-Line Resistor (provided) terminates the circuit.

### NMM-100P(A) OPERATION

Each NMM-100P(A) uses one of the available module addresses on an SLC loop. It responds to regular polls from the control panel and reports its type and the status (open/normal/short) of its Initiating Device Circuit (IDC).

### NMM-100P(A) SPECIFICATIONS

Nominal operating voltage: 15 to 32 VDC.

**Average operating current:** 350  $\mu$ A, 1 communication every 5 seconds, 47k EOL; 600  $\mu$ A Max. (Communicating, IDC Shorted).

**Maximum IDC wiring resistance:** 40 ohms.

**Maximum IDC Voltage:** 11 Volts.

**Maximum IDC Current:** 400  $\mu$ A.

**EOL resistance:** 47K ohms.

**Temperature range:** 32°F to 120°F (0°C to 49°C).

**Humidity range:** 10% to 93% noncondensing.

**Dimensions:** 1.3" (3.302 cm) high x 2.75" (6.985 cm) wide x 0.65" (1.651 cm) deep.

**Wire length:** 6" (15.24 cm) minimum.

## NZM-100(A) Interface Module

- Supports compatible two-wire smoke detectors.
- Supervises IDC wiring and connection of external power source.
- High noise (EMF/RFI) immunity.
- SEMS screws with clamping plates for ease of wiring.
- Direct Decade entry of address: 01 – 99 on FireWarden-100-2, 01 – 50 on FireWarden-50.
- LED flashes during normal operation.
- LED latches steady to indicate alarm on command from control panel.

The NZM-100(A) Interface Module is intended for use in intelligent, addressable systems, where the individual address of each module is selected using built-in rotary switches. This module allows intelligent panels to interface and monitor two-wire conventional smoke detectors. It transmits the status (normal, open, or alarm) of one full zone of conventional detectors back to the control panel. All two-wire detectors being monitored must be UL compatible with the module.

### NZM-100(A) APPLICATIONS

Use the NZM-100(A) to monitor a zone of two-wire smoke detectors. The monitored circuit may be wired as an NFPA Style B (Class B) or Style D (Class A) Initiating Device Circuit. A 3.9 K ohm End-of-Line Resistor (provided) terminates the end of the Style B or D (class B or A) circuit (maximum IDC loop resistance is 25 ohms). Install ELR across terminals 8 and 9 for Style D application.

### NZM-100(A) OPERATION

Each NZM-100(A) uses one of the available module addresses on an SLC loop. It responds to regular polls from the control panel and reports its type and the status (open/normal/short) of its Initiating Device Circuit (IDC). A flashing LED indicates that the module is in communication with the control panel. The LED latches steady on alarm (subject to current limitations on the loop).

### NZM-100(A) SPECIFICATIONS

**Nominal operating voltage:** 15 to 32 VDC.

**Maximum current draw:** 5.1 mA (LED on).

**Maximum IDC wiring resistance:** 25 ohms.

**Average operating current:** 300  $\mu$ A, 1 communication and 1 LED flash every 5 seconds, 3.9k eol.

**EOL resistance:** 3.9K ohms.

**External supply voltage (between Terminals T3 and T4):** DC voltage: 24 volts power limited. Ripple voltage: 0.1 Vrms maximum. Current: 90 mA per module maximum.

**Temperature range:** 32°F to 120°F (0°C to 49°C).

**Humidity range:** 10% to 93% noncondensing.

**Dimensions:** 4.5" (11.43 cm) high x 4" (10.16 cm) wide x 1.25" (3.175 cm) deep. Mounts to a 4" (10.16 cm) square x 2.125" (5.398 cm) deep box.

## NDM-100(A) Dual Monitor Module

The NDM-100(A) Dual Monitor Module is intended for use in intelligent, two-wire systems. It provides two independent two-wire initiating device circuits (IDCs) at two separate, consecutive addresses. It is capable of monitoring normally open contact fire alarm and supervisory devices. The module has a single panel-controlled LED.

**NOTE:** The NDM-100(A) provides two Style B (Class B) IDC circuits ONLY. Style D (Class A) IDC circuits are NOT supported in any application.

### NDM-100(A) SPECIFICATIONS

**Normal operating voltage range:** 15 to 32 VDC.

**Maximum current draw:** 6.4 mA (LED on).

**Average operating current:** 750  $\mu$ A (LED flashing).

**Maximum IDC wiring resistance:** 1,500 ohms.

**Maximum IDC Voltage:** 11 Volts.

**Maximum IDC Current:** 240  $\mu$ A

**EOL resistance:** 47K ohms.

**Maximum SLC Wiring resistance:** 40 Ohms.

**Temperature range:** 32° to 120°F (0° to 49°C).

**Humidity range:** 10% to 93% (non-condensing).

**Dimensions:** 4.5" (11.43 cm) high x 4" (10.16 cm) wide x 2.125" (5.398 cm) deep.

### NDM-100(A) AUTOMATIC ADDRESSING

The NDM-100(A) automatically assigns itself to two addressable points, starting with the original address. For example, if the NDM-100(A) is set to address "26", then it will automatically assign itself to addresses "26" and "27".

**NOTE:** "Ones" addresses on the NDM-100(A) are 0, 2, 4, 6, or 8 only. Terminals 6 and 7 use the first address, and terminals 8 and 9 use the second address.



#### CAUTION:

Avoid duplicating addresses on the system.

---

## Installation

NMM-100(A), NZM-100(A), and NDM-100(A) modules mount directly to a standard 4" (10.16 cm) square, 2.125" (5.398 cm) deep, electrical box. They may also be mounted to the SMB500 surface-mount box. Mounting hardware and installation instructions are provided with each module. All wiring must conform to applicable local codes, ordinances, and regulations. These modules are intended for power-limited wiring only.

The NMM-100P(A) module is intended to be wired and mounted without rigid connections inside a standard electrical box. All wiring must conform to applicable local codes, ordinances, and regulations.

## Agency Listings and Approvals

In some cases, certain modules may not be listed by certain approval agencies, or listing may be in process. Consult factory for latest listing status.

- **UL:** S635
- **ULC:** S635
- **FM Approved**
- **CSFM:** 7300-0028:0230 (NMM-100, NMM-100P, NZM-100); 7300-0028:0237 (NDM-100)

- **MEA:** 72-01-E Vol. 2 (NMM-100, NMM-100P, NZM-100); 227-03-E Vol. 3 (NDM-100)

## Product Line Information

**NOTE:** "A" suffix indicates ULC-listed model.

**NMM-100(A):** Monitor module.

**NMM-100P(A):** Monitor module, miniature.

**NZM-100(A):** Monitor module, two-wire detectors.

**NDM-100(A):** Monitor module, dual, two independent Class B circuits.

**SMB500:** Optional surface-mount backbox.

**NOTE:** See installation instructions and refer to the SLC Wiring Manual, PN 52304.

---

Notifier® and FireWarden® are registered trademarks and FireWatch™ is a trademark of Honeywell International Inc.  
©2010 by Honeywell International Inc. All rights reserved. Unauthorized use of this document is strictly prohibited.



This document is not intended to be used for installation purposes.  
We try to keep our product information up-to-date and accurate.  
We cannot cover all specific applications or anticipate all requirements.  
All specifications are subject to change without notice.



Made in the U.S. A.

For more information, contact Notifier. Phone: (203) 484-7161, FAX: (203) 484-7118.  
[www.notifier.com](http://www.notifier.com)



## Commander<sup>4</sup> Series Selectable Candela Evacuation Signals

## GCS/GCC 24VDC SERIES

### Applications

The GCS/GCC Series is a ceiling mount strobe or horn/strobe combination that offers dependable audible and visual alarms and the lowest current consumption.

The GCS/GCC offers tamperproof field selectable candela options of 15, 30, 75, 95, 115 and 150 candela.

The GCC horn offers a continuous or synchable temporal three in 2400Hz and mechanical tone. All tones are easy for the professional to change in the field by using switches. The models are shipped from the factory in the temporal three alarm mode.

The GC Series has a very minimal operating current and has a minimum flash rate of 1Hz regardless of input voltage.

The Commander<sup>4</sup> Series comes standard with the 4" mounting plate which incorporates the popular Super-Slide<sup>®</sup> feature that allows the installer to easily test for supervision. The product also features a locking mechanism which secures the product to the bracket without any screws showing.

The Commander<sup>4</sup> also features the patented Checkmate<sup>®</sup> - Instant Voltage Verification feature which allows the installer to check the voltage drop draw without removing the signal.

The GC Series appliances are ANSI/UL 464 and ANSI/UL 1971 listed for use with fire protective systems and are warranted for three years from the date of purchase.



### Product Listings

#### SIGNALING



LISTED



- ANSI/UL 464 and ANSI/UL 1971 Listed
- FM Approved
- CSFM: 7135-0569:122 (GCC)  
7125-0569:123 (GCS)
- MEA: 285-91-E

### Patents

- 7,375,617 May 20, 2008

### Product Compliance

- NFPA 72
- Americans with Disabilities Act (ADA)
- IBC/IFC/IRC
- City & State ordinances/Laws/Regulations
- Quality Management System is certified to:  
ISO 9001:2008



ASSEMBLED IN  
THE USA

### Standard Features

- Nominal voltage 24VDC
- Tamperproof field selectable candela options of 15, 30, 75, 95, 115 & 150
- Super-Slide<sup>®</sup> Bracket - Ease of Supervision Testing
- Checkmate<sup>®</sup> - Instant Voltage Verification
- Unit Dimensions: 6" (15.24 cm) x 2.6" (6.604 cm)
- Synchronize strobe and/or horn with Gentex AVSM Control Module
- Prewire entire system, install mounting bracket, then install signals
- Documented lower installation and operating costs
- Input Terminals 12 to 18 AWG
- Switch Selection for High or Low dBA
- Switch Selection for 2400Hz or Mechanical Tone
- Switch Selection for Continuous or Temporal 3
- Tamperproof re-entrant grill
- Surface mount with the GCSB (Gentex Ceiling Surface Mount Box)
- Silence audible while visual appliance will remain flashing (for use in accepted jurisdictions)
- Faceplate available in red or off-white

## GCS Series 24 Volt Ceiling Mount Selectable Strobe

Model Number	Part Number	Nominal Voltage	Candela
GCS24CR	904-1213-002	24VDC	15, 30, 75, 95, 115, 150
GCS24CW	904-1215-002	24VDC	15, 30, 75, 95, 115, 150
GCS24PCR	904-1214-002	24VDC	15, 30, 75, 95, 115, 150
GCS24PCW	904-1216-002	24VDC	15, 30, 75, 95, 115, 150

## GCC Series 24 Volt Ceiling Mount Selectable Horn/Strobe

Model Number	Part Number	Nominal Voltage	Candela	Reverberant dBA @ 10ft. per ANSI/UL 464	In Anechoic Room dBA @ 10ft.
GCC24CR	904-1209-002	24VDC	15, 30, 75, 95, 115, 150	81-86	90
GCC24PCR	904-1210-002	24VDC	15, 30, 75, 95, 115, 150	81-86	90
GCC24CW	904-1211-002	24VDC	15, 30, 75, 95, 115, 150	81-86	90
GCC24PCW	904-1212-002	24VDC	15, 30, 75, 95, 115, 150	81-86	90

### Model Designations:

C = Ceiling Mount

R = Red Faceplate

W = White Faceplate

All units are available in plain (no lettering).

**Plain units are non-returnable.**

## GC24 Product Strobe Current Ratings (mA)

	Candela	15cd	30cd	75cd	95cd	115cd	150cd
24VDC (16-33 Volts)	24VDC	72mA	101mA	167mA	200mA	214mA	286mA
	UL Max <sup>1</sup>	120mA	120mA	200mA	220mA	290mA	321mA

## GCC24 Product Horn Decibel and Current Ratings (mA)

Horn Mode	Minimum dBA @ 10ft. per ANSI/UL 464 (HIGH)	Minimum dBA @ 10ft. per ANSI/UL 464 (LOW)	Regulated 24VDC Max. Operating @ High Setting (mA)
Temp 3 2400Hz	83	75	23
Temp 3 Mechanical	81	73*	22
Continuous 2400Hz	86	78	23
Continuous Mechanical	84	76	22

### NOTES:

- Operating temperature: 32° to 120°F (0° to 49°C). The GC Series is not listed for outdoor use.
- The sound output for the temporal 3 tone is rated lower since the time the horn is off is averaged into the sound output rating. While the horn is producing a tone in the temporal 3 mode its sound pressure is the same as the continuous mode.
- For nominal and peak current across UL regulated voltage range for filtered DC power and unfiltered (FWR [Full Wave Rectified]) power, see installation manual.
- Gentex does not recommend using a coded or pulsing signaling circuit with any of our strobe products (see Technical Bulletin Number 014).
- \* Operating the horn in this mode at this voltage will result in not meeting the minimum ANSI/UL 464 reverberant sound level required for public mode fire protection service. These settings are acceptable only for private mode fire alarm use. Use the high dBA setting for public mode application (not applicable when using the chime tone. The chime tone is always private mode).

<sup>1</sup> RMS current ratings are per UL average RMS method. UL max current rating is the maximum RMS current within the listed voltage range (16-33VDC for 24VDC units). For strobes the UL max current is usually at the minimum listed voltage (16VDC for 24VDC units). For audibles the max current is usually at the maximum listed voltage. For unfiltered FWR ratings, see installation manual.

## Mounting Super-Slide®

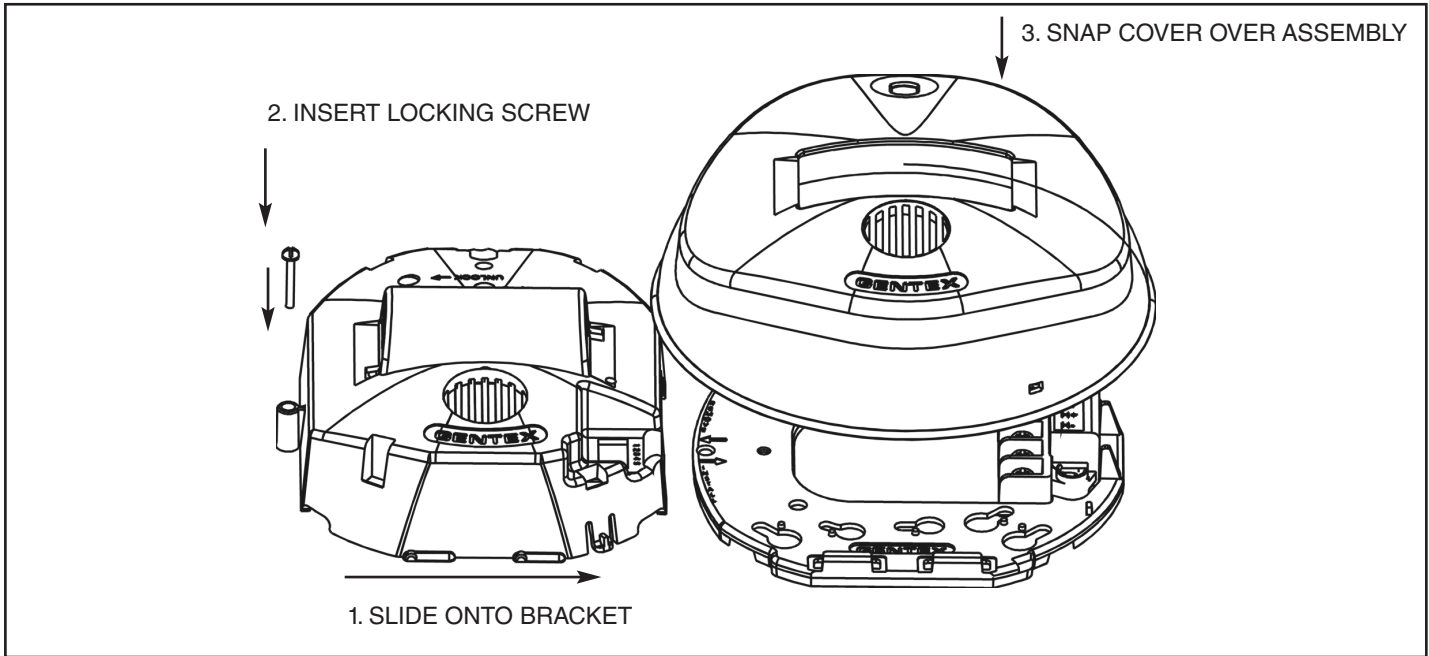

## Checkmate® Instant Voltage Verification

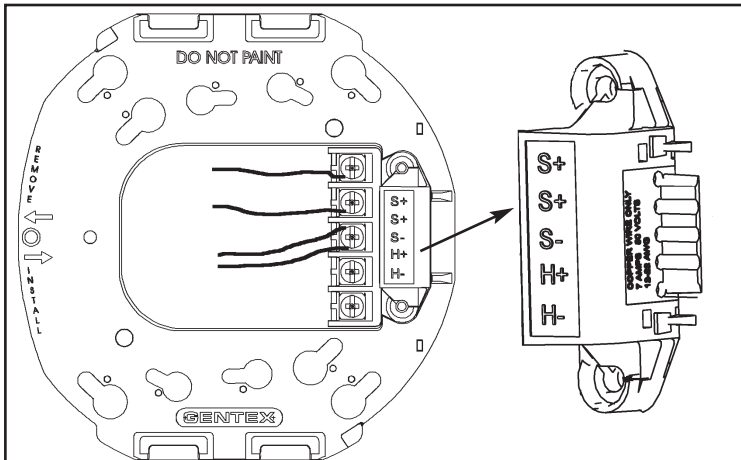

The access holes are provided in the back of the terminal block to allow the voltage to be measured directly without removing the device. Typically this would be done at the end of the line to confirm design criteria. Most measurements will be taken using the S+ and S- locations although access is provided to other locations. **NOTICE: CARE SHOULD BE TAKEN TO NOT SHORT THE TEST PROBES.**

## Switch Locations

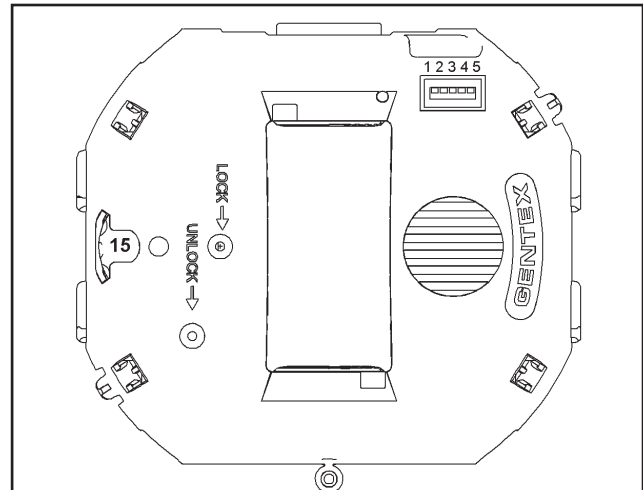

Switch positions 1 and 2 in the down position to select isolated horn and strobe power inputs. Switch 3 selects between temporal or non-temporal tone. Up is temporal. Switch 4 selects between mechanical or high frequency tone. Up is mechanical. Switch 5 selects between high or low dBA. Up is high dBA.

# GCS/GCC 24VDC SERIES

## Conventional GC Series Wiring Diagrams

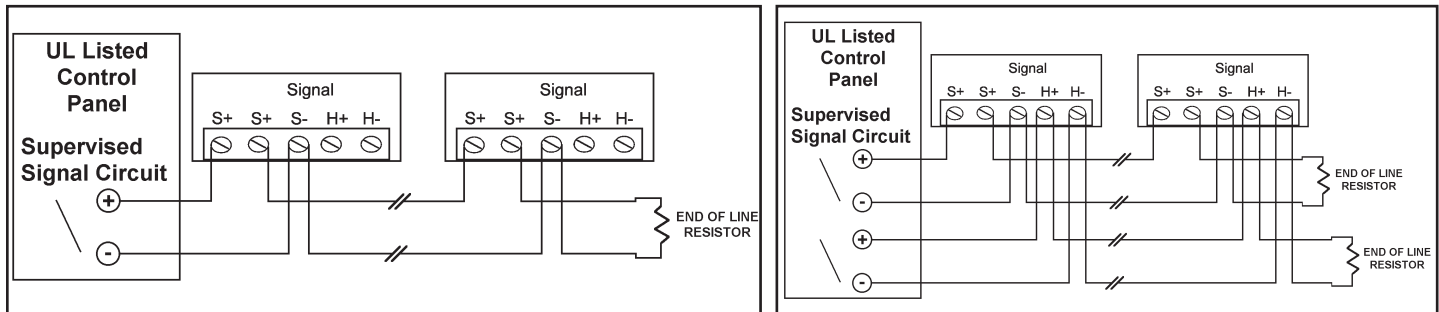

### NOTES:

- All strobes are designed to flash as specified with continuous applied voltage. Strobes should not be used on coded or pulsing signaling circuits. However, use of the Gentex AVSM control module or Gentex synchronization protocol is permitted to synchronize the strobe, horn and/or mute the horn. See Technical Bulletin 014 for additional information.
- **FOR SYNCHRONIZATION WIRING INFORMATION, REFERENCE AVSM CONTROL MODULE DATA SHEET (551-0031) AND/OR AVSM CONTROL MODULE MANUAL (550-0284) FOR SYNCHRONIZATION MODULE WIRING DIAGRAMS. AVSM CONTROL MODULE DATA SHEET AND MANUAL CAN BE OBTAINED AT <http://www.gentex.com> OR CALL GENTEX CORPORATION AT 1-800-436-8391.**

### Architect & Engineering Specifications

The visible and audible/visible signal shall be Gentex model GCS or GCC or approved equal and shall be listed by Underwriters Laboratories Inc. per ANSI/UL 1971 for the GCS and ANSI/UL 464 for the GCC. The notification appliance shall also be listed with the California State Fire Marshal (CSFM) and the Bureau of Standards and Appeals (NYC).

The notification appliance (combination audible/visible units and audible units only) shall produce a peak sound output of 90dBA or greater as measured at 24VDC in an anechoic chamber. The signaling appliance shall also have the capability to silence the audible signal while leaving the visible signal energized with the use of a single pair of power wires. Additionally, the user shall be able to select either continuous or temporal tone output with the temporal signal having the ability to be synchronized.

The audible/visible and visible signaling appliance shall also maintain a minimum flash rate of 1Hz or up to 2Hz regardless of power input voltage. The appliance shall have an operating current of 72mA or less at 24VDC for the 15 candela strobe circuit.

The appliance shall be polarized to allow for electrical supervision of the system wiring. The unit shall be provided with a mounting bracket with terminals with barriers for input/output wiring and be able to mount to a single gang or double gang box or double workbox with the use of an adapter plate. The unit shall have an input voltage range of 16-33 volts with either direct current or full wave rectified power.

The appliance shall be capable of test supervision without disconnecting wires, verify voltage without removing unit and be capable of mounting to a surface back box.

24 units per carton  
29 pounds per carton

# GENTEX CORPORATION

Fire Protection Products Group • [www.gentex.com](http://www.gentex.com)  
10985 Chicago Drive • Zeeland, Michigan 49464  
616.392.7195 • 1.800.436.8391 • 616.392.4219 Fax

Gentex Corporation reserves the right to make changes to the product data sheet at their discretion.

#### Important Notice:

These materials have been prepared by Gentex Corporation ("Gentex") for informational purposes only, are necessarily summary, and are not purporting to serve as legal advice and should not be used as such. Gentex makes no representations and warranties, express or implied, that these materials are complete and accurate, up-to-date, or in compliance with all relevant local, state and federal laws, regulations and rules. The materials do not address all legal considerations as there is inevitable uncertainty regarding interpretation of laws, regulations and rules and the application of such laws, regulations and rules to particular fact patterns. Each person's activities can differently affect the obligations that exist under applicable laws, regulations or rules. Therefore, these materials should be used only for informational purposes and should not be used as a substitute for seeking professional legal advice. Gentex will not be responsible for any action or failure to act in reliance upon the information contained in this material.

551-0051-06

## Commander<sup>3</sup> Series Selectable Candela Evacuation Signals

### Applications

The Commander<sup>3</sup> Series is a low profile strobe and horn/strobe combination that offers dependable audible and visual alarms and the absolute lowest current available.

The GE3 Series 24VDC offers tamperproof field selectable candela options of 15, 30, 60, 75, and 110 candela. The 12VDC offers tamperproof field selectable candela options of 15, 30, 60, and 75 candela.

The Commander<sup>3</sup> Series horn offers a continuous or synchable temporal three in 2400Hz and mechanical tone, a chime and whoop tone. All tones are easy for the professional to change in the field by the use of switches.

The GE3 Series has a minimal operating current and has a minimum flash rate of 1Hz regardless of input voltage.

The Commander<sup>3</sup> Series is shipped with a standard 4" metal mounting plate which incorporates the popular Super-Slide<sup>®</sup> feature that allows the installer to easily test for supervision. The product also features a locking mechanism which secures the product to the bracket without any screws showing.

The Commander<sup>3</sup> also features the patented Checkmate<sup>®</sup> - Instant Voltage Verification feature which allows the installer to check the voltage drop draw and match it to the blueprint.

The GE3 Series appliances are ANSI/UL 464 and ANSI/UL 1971, listed for use with fire protective systems and are warranted for three years from date of purchase.

### Standard Features

- Nominal voltage 12VDC and 24VDC
- 24VDC units have field selectable candela options of 15, 30, 60, 75 & 110
- 12VDC units have field selectable candela options of 15, 30, 60 & 75
- GEH horn is available in 12VDC or 24VDC
- Unit Dimensions: 5" (12.7 cm) high x 4.5" (11.43 cm) wide x 2.5" (6.35 cm) deep
- Super-Slide<sup>®</sup> Bracket - Ease of Supervision Testing
- Checkmate<sup>®</sup> - Instant Voltage Verification
- Synchronize strobe and/or horn with Gentex AVSM Control Module
- Prewire entire system, install mounting bracket, then install signals
- Documented lower installation and operating costs
- Input terminals accept 12 to 18 AWG
- Switch selection for high or low dBA
- Switch for chime, whoop, mechanical and 2400Hz tone
- Tamperproof re-entrant style grill
- Switch for continuous or temporal 3 tone (not available on whoop tone)
- Surface mount with the GSB (Gentex Surface Mount Box)
- Silence audible while visual appliance will remain flashing (for use in accepted jurisdictions)
- Faceplate available in red or off-white

## GEC3/GES3 12 & 24 VDC S E R I E S



### Product Listings

#### SIGNALING



- ANSI/UL 464 & ANSI/UL 1971 Listed
- CSFM: 7135-0569:122 (GEC3-24 & GEH-24)  
7125-0569:123 (GES3-24)  
7125-0569:129 (GES3-12)  
7135-0569:130 (GEC3-12 & GEH-12)
- MEA: 285-91-E (GEC3-24 & GES3-24)  
580-06-E (GEC3-12 & GES3-12)

### Patents

- 7,375,617 May 20, 2008

### Product Compliance

- NFPA 72
- Americans with Disabilities Act (ADA)
- IBC/IFC/IRC
- Quality Management System is certified to: ISO 9001:2008



## GEH 12VDC or 24VDC Low Profile Evacuation Horn

Model Number	Part Number	Nominal Voltage	Reverberant dBA at 10ft., per ANSI/UL 464	In Anechoic Room dBA at 10ft.
GEH12-R	904-1239-002	12VDC	62-82	100
GEH12-W	904-1241-002	12VDC	62-82	100
GEH24-R	904-1205-002	24VDC	62-82	100
GEH24-W	904-1207-002	24VDC	62-82	100

## GES3 12VDC or 24VDC Selectable Candela, Low Profile Evacuation Strobe

Model Number	Part Number	Nominal Voltage	Candela (ANSI/UL 1971)
GES3-12WR	904-1235-002	12 VDC	15, 30, 60, 75
GES3-12WW	904-1237-002	12 VDC	15, 30, 60, 75
GES3-24WR	904-1321-002	24 VDC	15, 30, 60, 75, 110
GES3-24WW	904-1319-002	24 VDC	15, 30, 60, 75, 110

## GEC3 12VDC or 24VDC Selectable Candela, Low Profile Evacuation Horn/Strobe

Model Number	Part Number	Nominal Voltage	Candela (ANSI/UL 1971)	Reverberant dBA at 10ft., per ANSI/UL 464	In Anechoic Room dBA at 10ft.
GEC3-12WR	904-1231-002	12 VDC	15, 30, 60, 75	62-82	100
GEC3-12WW	904-1233-002	12 VDC	15, 30, 60, 75	62-82	100
GEC3-24WR	904-1317-002	24 VDC	15, 30, 60, 75, 110	62-82	100
GEC3-24WW	904-1315-002	24 VDC	15, 30, 60, 75, 110	62-82	100

GE3 Product Strobe Current Ratings (mA)				
	12 VDC (8-17.5 Volts)		24 VDC (16-33 Volts)	
Candela	12VDC	UL Max <sup>1</sup>	24VDC	UL Max <sup>1</sup>
15cd	106mA	92mA	30mA	42mA
30cd	131mA	141mA	35mA	58mA
60cd	186mA	260mA	66mA	97mA
75cd	237mA	312mA	80mA	116mA
110cd			103mA	161mA

### Model Designations:

W = Wall mount

R = Red Faceplate    W = White Faceplate

All units are available in plain (no lettering).

**Plain units are non-returnable.**

ALERT bezel available for order

AGENT bezel available for order

GE3-12 Product Horn Current Ratings			
Horn Mode	Horn Decibel Levels		Regulated 12VDC Max. Operating @ High Setting (mA)
	Minimum SPL at 10ft., per ANSI/UL 464 (HIGH)	Minimum SPL at 10ft., per ANSI/UL 464 (LOW)	
Temp 3 2400Hz	76 dBA	69* dBA	29mA
Temp 3 Mechanical	75 dBA	68* dBA	26mA
Temp 3 Chime	62* dBA	60* dBA	13mA
Continuous 2400Hz	79 dBA	74* dBA	29mA
Continuous Mechanical	78 dBA	72* dBA	26mA
Continuous Chime	63* dBA	61* dBA	13mA
Whoop	78 dBA	71* dBA	55mA

GE3-24 Product Horn Current Ratings			
Horn Mode	Horn Decibel Levels		Regulated 24VDC Max. Operating @ High Setting (mA)
	Minimum SPL at 10ft., per ANSI/UL 464 (HIGH)	Minimum SPL at 10ft., per ANSI/UL 464 (LOW)	
Temp 3 2400Hz	78 dBA	71* dBA	28mA
Temp 3 Mechanical	76 dBA	70* dBA	25mA
Temp 3 Chime	70* dBA	66* dBA	15mA
Continuous 2400Hz	81 dBA	74* dBA	28mA
Continuous Mechanical	80 dBA	72* dBA	25mA
Continuous Chime	70* dBA	66* dBA	15mA
Whoop	82 dBA	69* dBA	56mA

### NOTES:

- Operating temperature: 32° to 120°F (0° to 49°C). The GEC3 and GES3 Series is **not** listed for outdoor use.
- For nominal and peak current across ANSI/UL regulated voltage range for filtered DC power and unfiltered (FWR [Full Wave Rectified]) power, see installation manual. 12VDC models are DC only.
- Gentex does not recommend using a coded or pulsing signaling circuit with any of our strobe products (see Technical Bulletin Number 014).**
- The sound output for the temporal 3 tone is rated lower since the time the horn is off is averaged into the sound output rating. While the horn is producing a tone in the temporal 3 mode its sound pressure is the same as the continuous mode.
- \* Operating the horn in this mode at this voltage will result in not meeting the minimum ANSI/UL 464 reverberant sound level required for public mode fire protection service. These settings are acceptable only for private mode fire alarm use. Use the high dBA setting for public mode application (not applicable when using the chime tone. The chime tone is always private mode).

<sup>1</sup> RMS current ratings are per ANSI/UL average RMS method. ANSI/UL max current rating is the maximum RMS current within the listed voltage range (16-33VDC for 24VDC units) (8-17VDC for 12VDC units). For strobes the UL max current is usually at the minimum listed voltage (16VDC for 24VDC units) (8VDC for 12VDC units). For audibles the max current is usually at the maximum listed voltage. For unfiltered FWR ratings, see installation manual.

## Tone Switch Locations

TONE	SWITCH POSITION		
	3	4	5
Mechanical Temporal 3	ON	ON	ON
Mechanical - Continuous	OFF	ON	ON
2400Hz - Temporal 3	ON	OFF	ON
2400Hz - Continuous	OFF	OFF	ON
Chime - Temporal 3	ON	ON	OFF
Chime - Continuous	OFF	ON	OFF
Whoop	ON	OFF	OFF
Whoop	OFF	OFF	OFF

### NOTE:

- Switch Positions 1 and 2 in the OFF position to select isolated horn and strobe power inputs
- Switch Position 6 ON = HIGH dBA
- Switch Position 6 OFF = LOW dBA

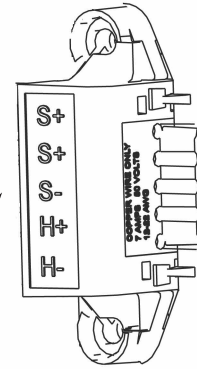
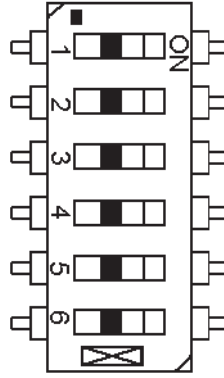

## Gentex Super-Slide® Mounting Bracket

Allows the installer to pre-wire the system, test for system supervision, remove the signal head until occupancy, switch out Gentex signals without changing mounting brackets and has locking edge connector for snap-in-place installation.

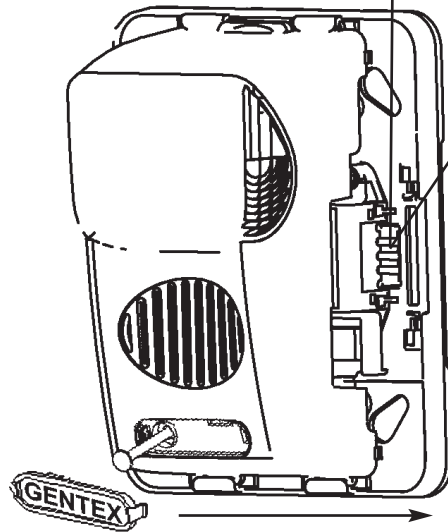

## Gentex Checkmate® Instant Voltage Verification

It is often necessary to confirm the voltage drop along a line of devices. The access holes are provided in the back of the terminal block to allow the voltage to be measured directly without removing the device. Typically this would be done at the end of the line to confirm design criteria. Most measurements will be taken using the S+ and S- locations although access is provided to other locations.

**NOTE:** Care should be taken to not short the test probes.

Candela selection slider switch. Depress center and slide switch to desire brightness level.

Break off pin and insert into hole at the bottom of the selector to lock candela setting. Signal must be removed from bracket and pin pushed forward from backside out of hole to change candela.

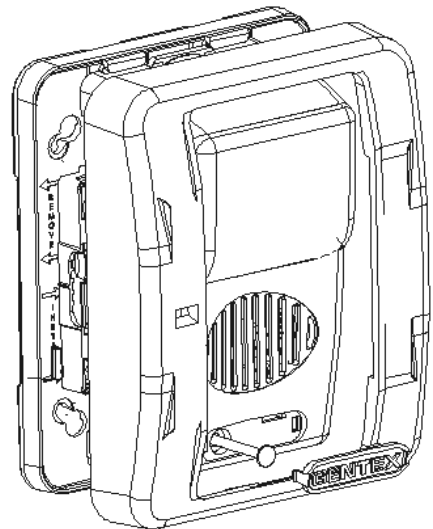
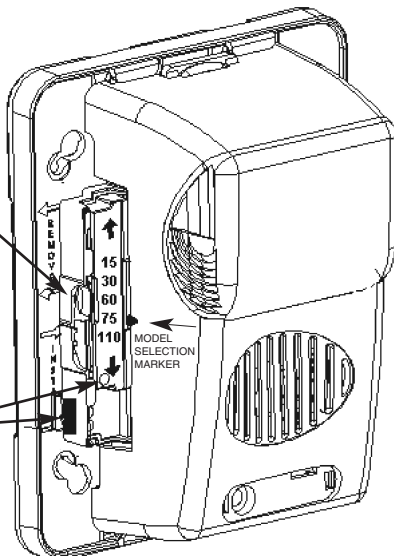

To remove bezel, grip both sides of bezel and pull in a downward and outward motion.

# GEC3/GES3 12 & 24 VDC S E R I E S

## Conventional Wiring Diagrams for Emergency Notification Evacuation Series

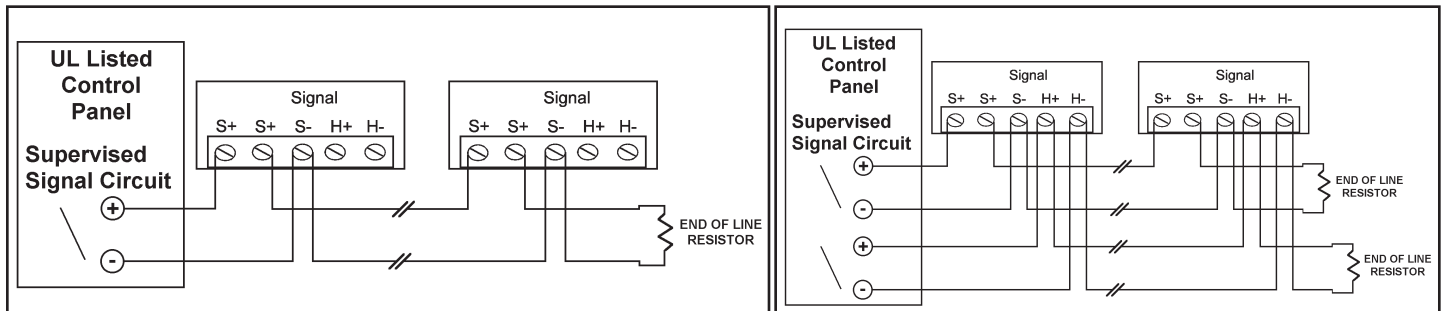

### NOTES:

- All strobes are designed to flash as specified with continuous applied voltage. Strobes should not be used on coded or pulsing signaling circuits. However, use of the Gentex AVSM control module or Gentex synchronization protocol is permitted to synchronize the strobe, horn and/or mute the horn. See Technical Bulletin 014 for additional information.
- **FOR SYNCHRONIZATION WIRING INFORMATION, REFERENCE AVSM CONTROL MODULE DATA SHEET (551-0031) AND/OR AVSM CONTROL MODULE MANUAL (550-0284) FOR SYNCHRONIZATION MODULE WIRING DIAGRAMS. AVSM CONTROL MODULE DATA SHEET AND MANUAL CAN BE OBTAINED AT <http://www.gentex.com> OR CALL GENTEX CORPORATION AT 1-800-436-8391.**
- When synchronizing the GE3 12VDC Series, the Gentex AVSM control module or Gentex synchronization protocol **MUST** be used.

### Architect & Engineering Specifications

The audible and/or visible signal shall be Gentex GEH, GES3, GEC3 Series or approved equal and shall be listed by Underwriters Laboratories, Inc. per ANSI/UL 1971 and/or ANSI/UL 464. The notification appliance shall also be listed with Factory Mutual Listing Service (FM) and the California State Fire Marshal (CSFM).

The notification appliance (combination audible/visible) shall produce a peak sound output of 100dBA or greater at 12VDC or 24VDC as measured in an anechoic chamber. The signaling appliance shall also have the capability to silence the audible signal while leaving the visible signal energized with the use of a single pair of power wires. Additionally, the user shall be able to select either continuous or temporal tone output with the temporal signal having the ability to be synchronized.

Unit shall be capable of being installed so that any unauthorized attempt to change the candela setting will result in a trouble signal at the fire alarm control panel.

The audible/visible and visible signaling appliance shall also maintain a minimum flash rate of 1Hz or up to 2Hz regardless of power input voltage. The strobe appliance shall have an operating current of 42mA or less at 24VDC for the 15Cd strobe circuit and 92mA or less at 12VDC for the 15Cd strobe circuit.

The appliance shall be polarized to allow for electrical supervision of the system wiring. The unit shall be provided with a mounting bracket with terminals and barriers for input/output wiring and be able to mount to a single gang or double gang box or double workbox without the use of an adapter plate. The unit shall have an input voltage range of 16-33 volts with either direct current or full wave rectified power for 24VDC models or a voltage range of 8-17.5 volts for 12VDC models.

The appliance shall be capable of testing supervision without disconnecting wires, verify voltage without removing unit and be capable of mounting to a surface back box.

24 units per carton  
28 pounds per carton

# GENTEX CORPORATION

Fire Protection Products Group • [www.gentex.com](http://www.gentex.com)  
10985 Chicago Drive • Zeeland, Michigan 49464  
616.392.7195 • 1.800.436.8391 • 616.392.4219 Fax

Gentex Corporation reserves the right to make changes to the product data sheet at their discretion.

#### Important Notice:

These materials have been prepared by Gentex Corporation ("Gentex") for informational purposes only, are necessarily summary, and are not purporting to serve as legal advice and should not be used as such. Gentex makes no representations and warranties, express or implied, that these materials are complete and accurate, up-to-date, or in compliance with all relevant local, state and federal laws, regulations and rules. The materials do not address all legal considerations as there is inevitable uncertainty regarding interpretation of laws, regulations and rules and the application of such laws, regulations and rules to particular fact patterns. Each person's activities can differently affect the obligations that exist under applicable laws, regulations or rules. Therefore, these materials should be used only for informational purposes and should not be used as a substitute for seeking professional legal advice. Gentex will not be responsible for any action or failure to act in reliance upon the information contained in this material.

551-0050-06