

PARIS FARMERS UNION  
55 WARREN AVENUE  
PORTLAND, MAINE



93 Pitt Street  
Portland, ME 04103  
207.747-5975 voice  
822 Grover Hill Rd.  
Bethel, ME 04217  
207.824.7237 voice/fax  
info@smithreuter.com

FIRST FLOOR PLAN

215-3  
09/11/14  
A2

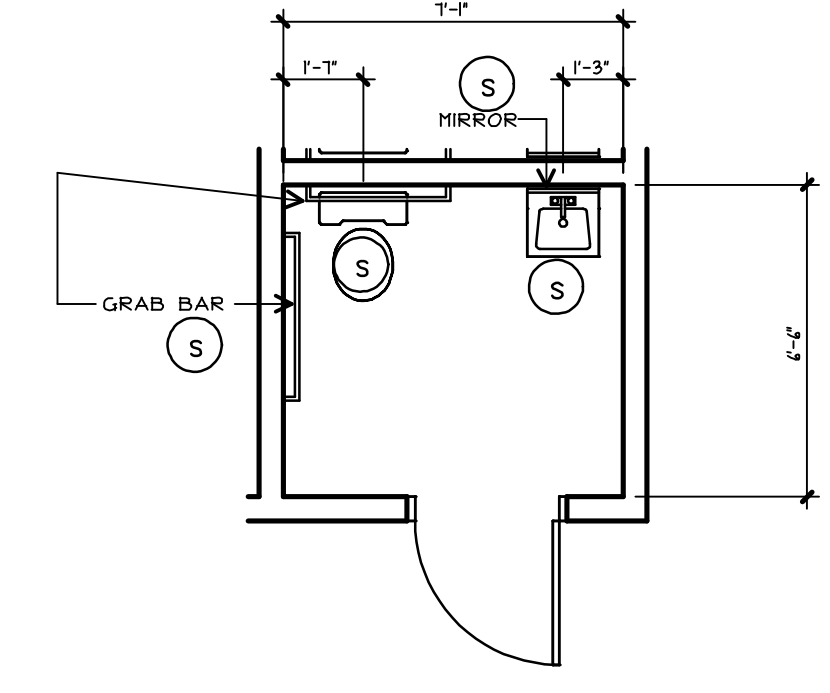

ENLARGED TOILET PLAN  
1/4" = 1'-0"

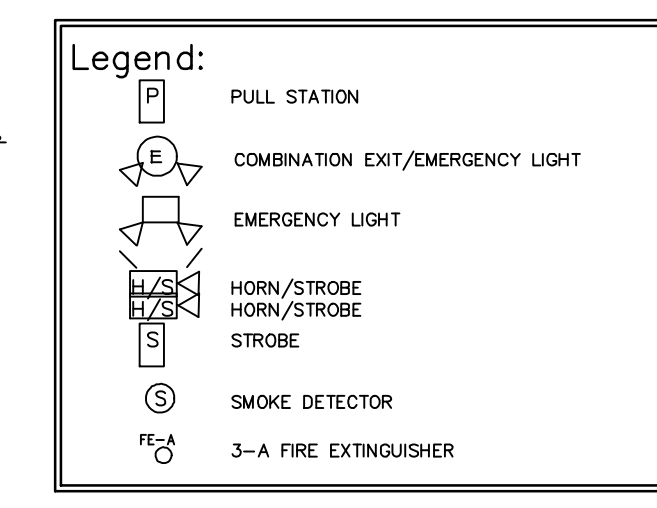
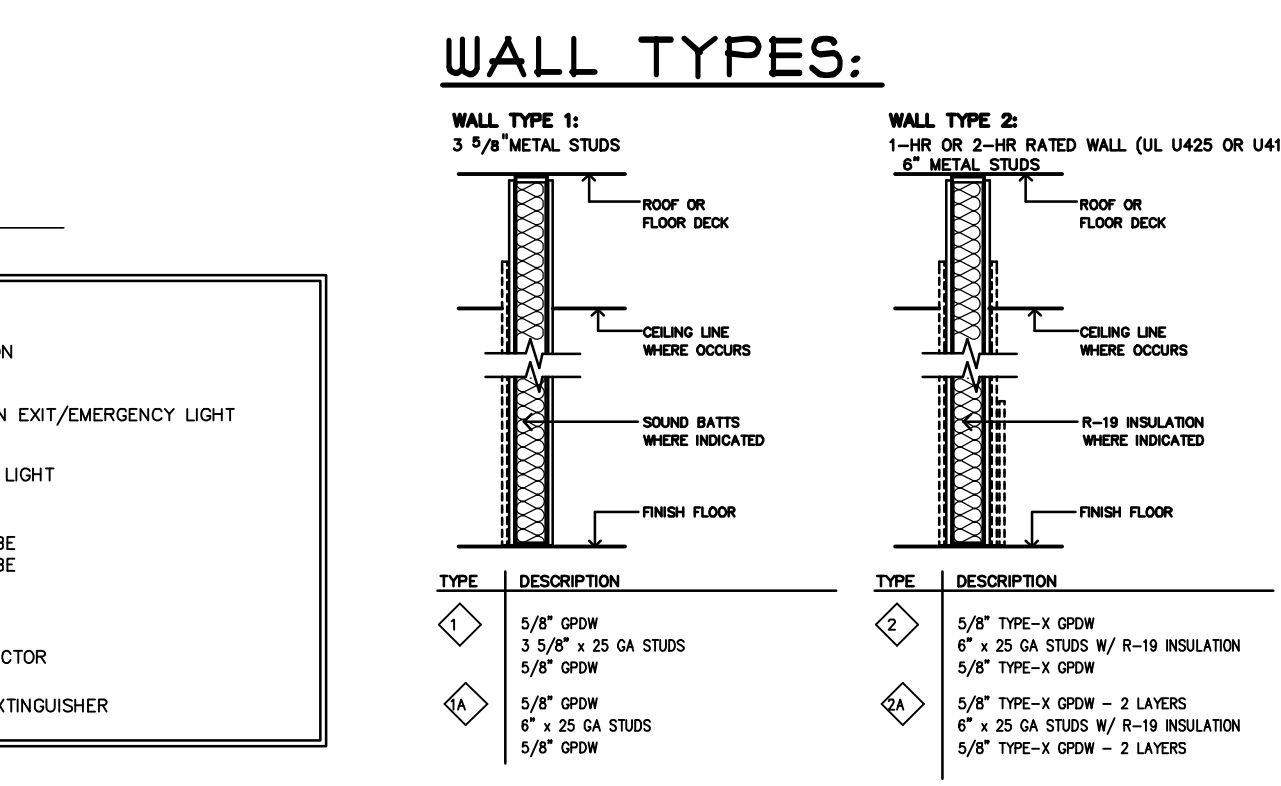
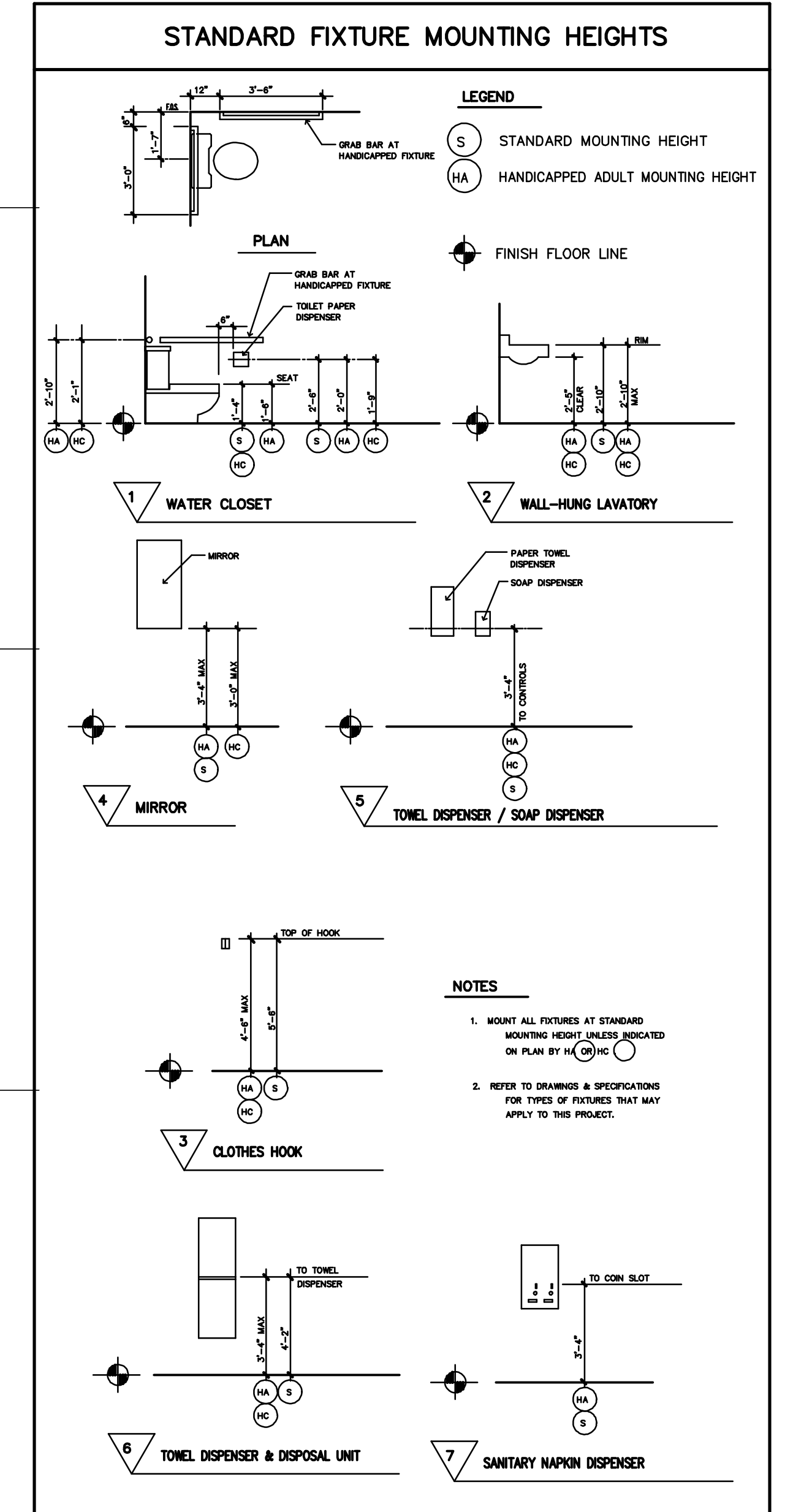

NOTES:  
ALL COLUMNS 4" X 4" STEEL FRAME BUILDING BY MUOX  
10,930 SF OF MERCANTILE, 1 STORY BUILDING IS FULLY SPRINKLERED-OCCUPANT LOAD 30 SF/PERSON OR 36 PEOPLE  
1395 SF STORAGE GROUP 5 - ORDINARY HAZARD 1 STORY BUILDING IS FULLY SPRINKLERED  
OCCUPANT LOAD 300 SF/PERSON OR 24 PEOPLE  
430 SF STORAGE - HAZARDOUS GROUP 1 OR COMBUSTIBLE LIQUIDS CLASS III-A 1 STORY BUILDING IS FULLY SPRINKLERED  
OCCUPANT LOAD 300 SF/PERSON OR 2 PEOPLE  
ALTHOUGH TOTAL OCCUPANT LOAD BY CODE IS 34 WHICH WOULD REQUIRE 4 TOILETS BY IBC  
OTHER SUBMITTED LETTER STATING IS MAX CUSTOMERS AT BUSIEST TIME AND 2 TOILETS ARE PROVIDED  
MERCANTILE GROUP 1  
3,000-30,000 SQUARE FEET  
1 HOUR FIRE SEPARATION BETWEEN OTHER SPACES BECAUSE BUILDING IS FULLY SPRINKLERED  
ORDINARY HAZARD  
TRAVEL DISTANCE NOT MORE THAN 250' TO EXIT  
2 EXITS REQUIRED  
EXIT THROUGH STORAGE IS ALLOWED IF A 44" AISLE WITH FIXED BARRIERS IS CONTINUOUSLY MAINTAINED  
HAZARDOUS STORAGE GROUP 1  
430 SF STORAGE OF COMBUSTIBLE LIQUIDS CLASS III-A 1 STORY BUILDING IS FULLY SPRINKLERED  
2 HOUR FIRE SEPARATION BETWEEN OTHER SPACES BECAUSE BUILDING IS FULLY SPRINKLERED

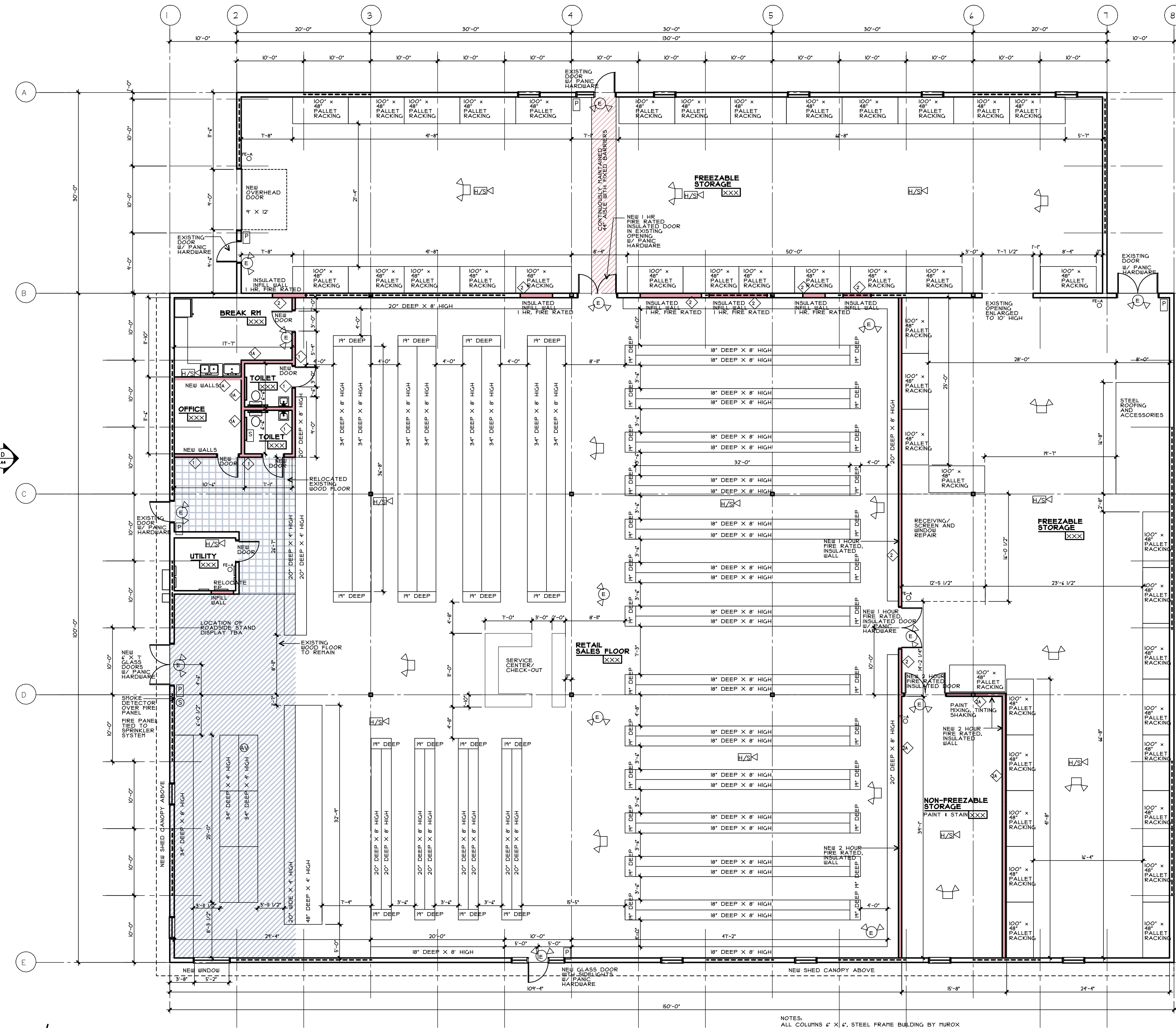

FIRST FLOOR PLAN  
1/8" = 1'-0"

