

7744F/7788F

UL Listed

AES IntelliNet
CORPORATION | For Alarm Monitoring

RF Subscriber Unit

UL Fire, AA Burglary and NFPA-72 Compliant

UL Listed

UL Listed Central Station

Remote Station

864 Ed. 9, 827, 1610, 365, 681

CSFM

*NFPA
RF Section 8.6.3.5*

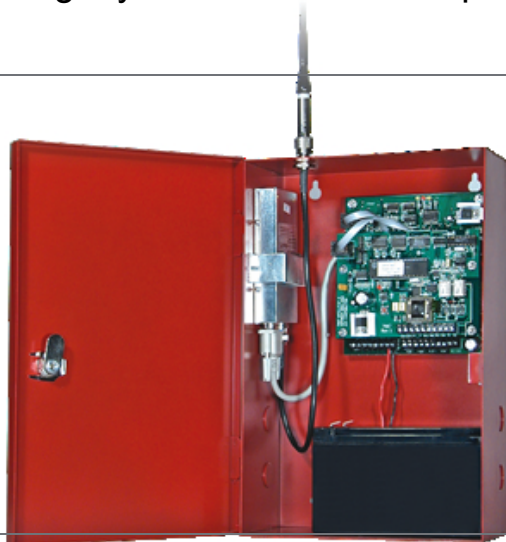

Advanced Wireless Alarm Monitoring

The 7744F/7788F smart subscriber unit links an alarm panel to an alarm monitoring central station. This 2-way transceiver and repeater in one is housed in a full size locking steel cabinet for superior performance. The 7744F/7788F supports a wide range of inputs such as NO/NC/EOL and direct voltage. It automatically senses wire and antenna cuts, and monitors battery and AC power status. Advanced status reporting, self-diagnostics and a built-in power supply make the 7744F/7788F the first choice for all wireless alarm communication needs.

Full Data for Fire and Burglary

Use with the optional Firetap for full fire data or the IntelliTap for full fire and burglary data.

Available Configurations

7744F – 4 reversing polarity inputs plus 4 programmable EOL inputs

7788F – Programmable EOL inputs with 8 zones

Available Options

FireTap 7770
IntelliTap 7067
NEMA 4 Enclosure
High Gain Antenna
Additional Back Up Battery
Available in Burglary Beige or Fire Red

- Options for Full Data for Fire and Burglary
- Available in 7744F & 7788F Zone Configurations
- Built-in Power Supply and Battery Charger
- Local Annunciation Options on Board

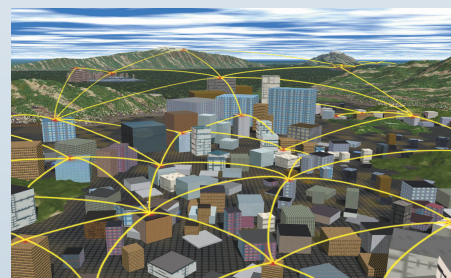

Wireless mesh networking is an innovative technology adopted by many industries with applications that need to communicate data over a large geographic area with a high level of reliability at a low total cost of ownership.

The advanced design and 2-way communications capability provides easy installation, expansion, and management when compared to alternative communication methods, both wired and wireless.

7744F/7788F RF Subscriber Unit

Technical Specifications

Radio

Standard CSAA frequency ranges: 450-470 MHz and 130-174 MHz, VHF and UHF. Others available

Standard Output Power

2 watts (requires FCC license)

Power Input

16.5 VAC, 40VA UL listed
Class II transformer required

Voltage

12 VDC nominal

Current

175mA standby; 800mA transmit

Alarm Signal Inputs

- 4 individually programmable Zones: NO/NC/EOL, trouble restore
- RS-232
- Reversing voltage (7744F only) 12 or 24 VDC

Operating Temperature Range

0° to 50°C, 32° to 122°F

Storage Temperature Range

-10° to 60°C, 14° to 140°F

Relative Humidity Range

0-85% RHC non-condensing

Back up Battery

12V, 7.5 Ahr

Low Battery Reporting

22.5-minute test cycle

AC Status

Reports to central station after approximately 60 minutes without AC power, reports power restored after approximately 60 minutes of restored power. programmable from 60 to 180 minutes

Antenna Cut (local reporting)

Form 'C' Contact 1 AMP

Size

13.25"H x 8.5"W x 4.3"D
34cm x 21.5cm x 11cm

Weight

6.4 lbs, 2.9 Kilograms
(excluding battery)

Colors

Available in standard
Burglary Beige or Fire Red
Please specify when ordering

Available Options

- 7788F RF subscriber unit with 8 EOL inputs
 - 7744F RF subscriber unit with 4 EOL inputs and 4 reverse polarity inputs
 - 7770 - FireTap
 - 7067 - IntelliTap
 - NEMA 4 Enclosure
- Please specify when ordering

Available configurations

- 7788F, 8 EOL inputs
- 7744F, 4 EOL inputs w/4 reverse polarity inputs

AES-IntelliNet™ is the industry leader in delivering high quality wireless mesh networks to the fire and security industry in commercial, corporate, government, and educational applications with its broad line of products and advanced network management tools. Users of AES-IntelliNet networks have gained significant revenue, communications, and cost advantages while meeting the high standards of reliability required for the fire and security industry. AES-IntelliNet alarm monitoring systems are deployed at hundreds of thousands of locations in over 130 countries.



For more information

Call 800-AES-NETS (800-237-6387)

AES Corporation | 285 Newbury Street | Peabody, MA 01960 USA
Tel. +1 978-535-7310 | Fax +1 978-535-7313 | Email info@aes-intellinet.com
Web www.aes-intellinet.com

Copyright 2009 AES Corporation
AES-IntelliNet is a registered trademark of AES Corporation

7744F/7788F/08/09

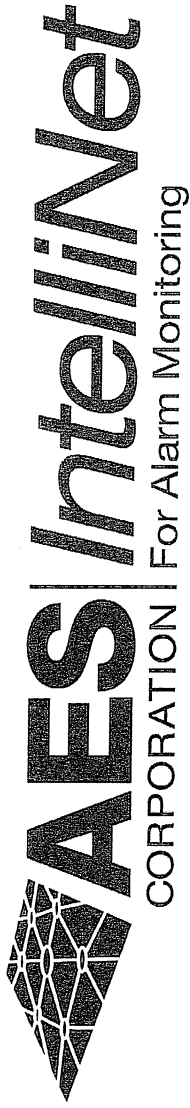

CERTIFICATE OF COMPLETION

AWARDED TO

Jack Valdez

for successful completion of Level One

AES-IntelliNet CEU Training

Completed July 17, 2013
Awarded by AES Corporation
Peabody, Massachusetts 01960 U.S.A.

Rick DiStefano
Sr. Support Specialist

NBG-12LX

Addressable Manual Pull Station

**Intelligent/Addressable Devices**

General

The Notifier NBG-12LX is a state-of-the-art, dual-action (i.e., requires two motions to activate the station) pull station that includes an addressable interface for any Notifier intelligent control panel except FireWarden series panels, and the NSP-25 panel. Because the NBG-12LX is addressable, the control panel can display the exact location of the activated manual station. This leads fire personnel quickly to the location of the alarm.

Features

- Maintenance personnel can open station for inspection and address setting without causing an alarm condition.
- Built-in bicolor LED, which is visible through the handle of the station, flashes in normal operation and latches steady red when in alarm.
- Handle latches in down position and the word “ACTIVATED” appears to clearly indicate the station has been operated.
- Captive screw terminals wire-ready for easy connection to SLC loop (accepts up to 12 AWG/3.25 mm² wire).
- Can be surface mounted (with SB-10 or SB-I/O) or semi-flush mounted. Semi-flush mount to a standard single-gang, double-gang, or 4" (10.16 cm) square electrical box.
- Smooth dual-action design.
- Meets ADAAG controls and operating mechanisms guidelines (Section 4.1.3[13]); meets ADA requirement for 5 lb. maximum activation force.
- Highly visible.
- Attractive shape and textured finish.
- Key reset.
- Includes Braille text on station handle.
- Optional trim ring (BG12TR).
- Meets UL 38, Standard for Manually Actuated Signaling Boxes.
- Up to 99 NBG-12LX stations per loop on CLIP protocol loops.
- Up to 159 NBG-12LX stations per loop on FlashScan® protocol loops.
- Dual-color LED blinks green to indicate normal on FlashScan® systems.

Construction

Shell, door, and handle are molded of durable polycarbonate material with a textured finish.

Specifications

- **Shipping Weight:** 9.6 oz. (272.15 g)
- **Normal operating voltage:** 24 VDC.
- **Maximum SLC loop voltage:** 28.0 VDC.
- **Maximum SLC standby current:** 375 µA.
- **Maximum SLC alarm current:** 5 mA.
- **Temperature Range:** 32°F to 120°F (0°C to 49°C)
- **Relative Humidity:** 10% to 93% (noncondensing)
- **For use indoors in a dry location**



The **NBG-12LX**
Addressable Manual Pull Station

Installation

The NBG-12LX will mount semi-flush into a single-gang, double-gang, or standard 4" (10.16 cm) square electrical outlet box, or will surface mount to the model SB-10 or SB-I/O surface backbox. If the NBG-12LX is being semi-flush mounted, then the optional trim ring (BG12TR) may be used. The BG12TR is usually needed for semi-flush mounting with 4" (10.16 cm) or double-gang boxes (not with single-gang boxes).

Operation

Pushing in, then pulling down on the handle causes it to latch in the down/activated position. Once latched, the word “ACTIVATED” (in bright yellow) appears at the top of the handle, while a portion of the handle protrudes from the bottom of the station. To reset the station, simply unlock the station with the key and pull the door open. This action resets the handle; closing the door automatically resets the switch.

Each manual station, on command from the control panel, sends data to the panel representing the state of the manual switch. Two rotary decimal switches allow address settings (1 – 159 on FlashScan® systems, 1 – 99 on CLIP systems).

Architectural/Engineering Specifications

Manual Fire Alarm Stations shall be non-coded, with a key-operated reset lock in order that they may be tested, and so designed that after actual Emergency Operation, they cannot be restored to normal except by use of a key. An operated station shall automatically condition itself so as to be visually detected as activated. Manual stations shall be constructed of red-colored polycarbonate material with clearly visible operating instructions provided on the cover. The word FIRE shall appear on the front of the stations in white letters, 1.00 inches (2.54 cm) or larger. Stations shall be suitable for surface mounting on matching backbox SB-10 or SB-I/O; or semi-flush mounting on a standard single-gang, double-gang, or

4" (10.16 cm) square electrical box, and shall be installed within the limits defined by the Americans with Disabilities Act (ADA) or per national/local requirements. Manual Stations shall be Underwriters Laboratories listed.

Manual stations shall connect with two wires to one of the control panel SLC loops. The manual station shall, on command from the control panel, send data to the panel representing the state of the manual switch. Manual stations shall provide address setting by use of rotary decimal switches.

The loop poll LED shall be clearly visible through the front of the station. The LED shall flash while in the normal condition, and stay steadily illuminated when in alarm.

Product Line Information

NBG-12LX: Dual-action addressable pull station. Includes key locking feature. (Listed for Canadian and non-Canadian applications.)

NBG-12LXSP: Spanish/English labelled version.

NBG-12LXP: Portuguese labelled version.

SB-10: Surface backbox; metal.

SB-I/O: Surface backbox; plastic.

BG12TR: Optional trim ring.

17021: Keys, set of two.

NY-Plate: New York City trim plate.

Agency Listings and Approvals

In some cases, certain modules or applications may not be listed by certain approval agencies, or listing may be in process. Consult factory for latest listing status.

- **UL/ULC Listed:** S692 (listed for Canadian and non-Canadian applications).
- **MEA:** 67-02-E.
- **CSFM:** 7150-0028:0199.
- **FDNY:** COA #6085 (NFS2-640), COA #6098 (NFS2-3030).
- **BSMI:** CI313066760047.
- **U.S. Coast Guard.**
- **Lloyd's Register.**
- **FM Approved.**

Patented: U.S. Patent No. D428,351; 6,380,846; 6,314,772; 6,632,108.

NOTIFIER® and FlashScan® are registered trademarks of Honeywell International Inc.

©2012 by Honeywell International Inc. All rights reserved. Unauthorized use of this document is strictly prohibited.



This document is not intended to be used for installation purposes.
We try to keep our product information up-to-date and accurate.
We cannot cover all specific applications or anticipate all requirements.
All specifications are subject to change without notice.



Made in the U.S. A.

For more information, contact Notifier. Phone: (203) 484-7161, FAX: (203) 484-7118.
www.notifier.com

FSP-851(A) Series

Intelligent Plug-In Photoelectric Smoke Detectors with FlashScan®



Intelligent/Addressable Devices

General

Notifier FSP-851(A) Series intelligent plug-in smoke detectors with integral communication provide features that surpass conventional detectors. Detector sensitivity can be programmed in the control panel software. Sensitivity is continuously monitored and reported to the panel. Point ID capability allows each detector's address to be set with rotary, decimal address switches, providing exact detector location for selective maintenance when chamber contamination reaches an unacceptable level. The FSP-851(A) photoelectric detector's unique optical sensing chamber is engineered to sense smoke produced by a wide range of combustion sources. Dual electronic thermistors add 135°F (57°C) fixed-temperature thermal sensing on the FSP-851T(A). The FSP-851R(A) is a remote test capable detector for use with DNR(A)/DNRW duct detector housings. FSP-851(A) series detectors are compatible with Notifier Onyx and CLIP series Fire Alarm Control Panels (FACPs).

FlashScan® (U.S. Patent 5,539,389) is a communication protocol developed by Notifier that greatly increases the speed of communication between analog intelligent devices. Intelligent devices communicate in a grouped fashion. If one of the devices in the group has new information, the panel's CPU stops the group poll and concentrates on single points. The net effect is response speed greater than five times that of earlier designs.

Features

- Sleek, low-profile design.
- Addressable-analog communication.
- Stable communication technique with noise immunity.
- Low standby current.
- Two-wire SLC connection.
- Compatible with FlashScan® and CLIP protocol systems.
- Rotary, decimal addressing (1-99 on CLIP systems, 1-159 on FlashScan systems).
- Optional remote, single-gang LED accessory.
- Dual LED design provides 360° viewing angle.
- Visible bi-color LEDs blink green every time the detector is addressed, and illuminate steady red on alarm (*FlashScan systems only*).
- Remote test feature from the panel.
- Walk test with address display (an address on 121 will blink the detector LED: 12-[pause]-1 (*FlashScan systems only*)).
- Built-in functional test switch activated by external magnet.
- Built-in tamper-resistant feature.
- Sealed against back pressure.
- Constructed of off-white fire-resistant plastic, designed to commercial standards, and offers an attractive appearance.
- 94-5V plastic flammability rating.
- SEMS screws for wiring of the separate base.
- Optional relay, isolator, and sounder bases.

Specifications

Sensitivity: 0.5% to 2.35% per foot obscuration

Size: 2.1" (5.3 cm) high; base determines diameter.

- **B210LP(A):** 6.1" (15.5 cm) diameter.
- **B501(A):** 4.1" (10.4 cm) diameter.
- **B200S(A):** 6.875" (17.46 cm) diameter.



FSP-851(A) in B210LP(A) Base

B210-2951.jpg

- **B200SR(A):** 6.875" (17.46 cm) diameter.
- **B224RB(A):** 6.2" (15.748 cm) diameter.
- **B224BI(A):** 6.2" (15.748 cm) diameter.

Shipping Weight: 5.2oz. (147g).

Operating Temperature range: FSP-851(A), 0°C to 49°C (32°F to 120°F). FSP-851T(A), 0°C to 38°C (32°F to 100°F). Low temperature signal for FSP-851T(A) at 45°F +/- 10°F (7.22°C +/- 5.54°C). FSP-851R(A) installed in a DNR(A)/DNRW, -20°C to 70°C (-4°F to 158°F).

UL/ULC Listed Velocity Range: 0-4000 ft/min. (1219.2 m/min.), suitable for installation in ducts.

Relative Humidity: 10%-93% noncondensing.

Thermal Ratings: Fixed-temperature setpoint 135°F (57°C).

DETECTOR SPACING AND APPLICATIONS

Notifier recommends spacing detectors in compliance with NFPA 72. In low airflow applications with smooth ceiling, space detectors 30 feet (9.144m) for ceiling heights 10 feet (3.148m) and higher. For specific information regarding detector spacing, placement, and special applications refer to NFPA 72. *System Smoke Detector Application Guide*, document A05-1003, is available at systemsensor.com

ELECTRICAL SPECIFICATIONS

Voltage Range: 15-32 volts DC peak.

Standby Current (max. avg.): 300µA @ 24VDC (one communication every five seconds with LED enabled).

LED Current (max.): 6.5mA @ 24 VDC ("ON").

Installation

FSP-851(A) plug-in detectors use a separate base to simplify installation, service, and maintenance. A special tool allows maintenance personnel to plug in and remove detectors without using a ladder.

Mount base (all base types) on an electrical backbox which is at least 1.5" (3.81 cm) deep. For a chart of compatible junction boxes, see DN-60054.

NOTE: 1) Because of inherent supervision provided by the SLC loop, end-of-line resistors are not required. Wiring "T-taps" or branches are permitted for Style 4 (Class "B") wiring. 2) When using relay or sounder bases, consult the ISO-X(A) installation

sheet 156-1380 for device limitations between isolator modules and isolator bases.

Agency Listings and Approvals

These listings and approvals apply to the modules specified in this document. In some cases, certain modules or applications may not be listed by certain approval agencies, or listing may be in process. *Consult factory for latest listing status.*

- **UL Listed:** S1115.
- **ULC Listed:** S1115 (FSP-851A, FSP-851RA, FSP-851TA).
- **MEA Listed:** 225-02-E .
- **FM Approved.**
- **CSFM:** 7272-0028:0206 .
- **Maryland State Fire Marshal:** Permit # 2122 .
- **BSMI:** CI313066760036.
- **CCCF:** Certif. # 2004081801000017 (FSP-851T)
Certif. # 2004081801000016 (FSP-851).
- **U.S. Coast Guard:** 161.002/42/1 (NFS-640); 161.002/50/0 (NFS2-640/NFS-320/NFS-320C, excluding B210LP(A)).
- **Lloyd's Register:** 11/600013 (NFS2-640/NFS-320/NFS-320C, excluding B210LP(A)).

Product Line Information

NOTE: "A" suffix indicates ULC Listed model.

FSP-851: Low-profile intelligent photoelectric sensor. Must be mounted to one of the bases listed below.

FSP-851A: Same as FSP-851 but with ULC listing.

FSP-851T: Same as FSP-851 but includes a built-in 135°F (57°C) fixed-temperature thermal device.

FSP-851TA: Same as FSP-851T but with ULC listing.

FSP-851R: Low-profile intelligent photoelectric sensor, remote test capable. For use with DNRA/DNRW.

FSP-851RA: Same as FSP-851R but with ULC listing. For use with DNRA.

INTELLIGENT BASES

NOTE: "A" suffix indicates ULC Listed model.

NOTE: For details on intelligent bases, see DN-60054.

B210LP(A): Standard U.S. flanged low-profile mounting base.

B210LPBP: Bulk pack of B210LP; package contains 10.

B501(A): Standard European flangeless mounting base.

B501BP: Bulk pack of B501; package contains 10.

B200S(A): Intelligent, programmable sounder base capable of producing sound output in high or low volume with ANSI Temporal 3, ANSI Temporal 4, continuous tone, marching tone, and custom tone.

B200SR(A): Intelligent sounder base capable of producing sound output with ANSI Temporal 3 or continuous tone. Replaces B501BH series bases in retrofit applications.

B224RB(A): Plug-in System Sensor **relay** base. Screw terminals: up to 14 AWG (2.0 mm²). Relay type: Form-C. Rating: 2.0 A @ 30 VDC resistive; 0.3 A @ 110 VDC inductive; 1.0 A @ 30 VDC inductive.

B224BI(A): Plug-in System Sensor **isolator** detector base. Maximum 25 devices between isolator bases .

ACCESSORIES

F110: Retrofit flange to convert B210LP(A) to match the B710LP(A) profile, or to convert older high-profile bases to low-profile.

F110BP: Bulk pack of F110; package contains 15.

F210: Replacement flange for B210LP(A) base.

RA100Z(A): Remote LED annunciator. 3 – 32 VDC. Mounts to a U.S. single-gang electrical box. For use with B501(A) and B210LP(A) bases only.

SMB600: Surface mounting kit

M02-04-00: Test magnet.

M02-09-00: Test magnet with telescoping handle.

XR2B: Detector removal tool. Allows installation and/or removal of detector heads from bases in high ceiling applications.

XP-4: Extension pole for XR2B. Comes in three 5-foot (1.524 m) sections.

T55-127-010: Detector removal tool without pole.

BCK-200B: Black detector covers for use with FSP-851(A) only; box of 10.

WCK-200B: White detector covers for use with FSP-851(A) only; box of 10.

-Notifier® and FlashScan® are registered trademarks of Honeywell International Inc.

©2011 by Honeywell International Inc. All rights reserved. Unauthorized use of this document is strictly prohibited.



This document is not intended to be used for installation purposes.
We try to keep our product information up-to-date and accurate.
We cannot cover all specific applications or anticipate all requirements.
All specifications are subject to change without notice.



Made in the U.S. A.

For more information, contact Notifier. Phone: (203) 484-7161, FAX: (203) 484-7118.
www.notifier.com

InnovairFlex

Intelligent Non-Relay Photoelectric Duct Smoke Detector



Intelligent Devices

General

The Notifier InnovairFlex DNR intelligent non-relay photoelectric duct smoke detector and DNRW watertight non-relay photoelectric duct smoke detector feature a pivoting housing that fits both square and rectangular footprints capable of mounting to a round or rectangular duct.

DNRW duct smoke detector, with its NEMA-4 rating, is listed as a watertight, UV resistant enclosure providing protection against falling dirt, rain, and windblown dust, splashing and hose directed water, allowing operators to use the detector in the most extreme environments.

These units sense smoke in the most challenging conditions, operating in airflow speeds of 100 to 4,000 feet per minute, temperatures of -4 degrees F to 158 degrees F, and a humidity range of 0 to 95 percent (non-condensing.)

An improved cover design isolates the sensor head, which allows for ease of maintenance. A cover tamper feature indicates a trouble signal for a removed or improperly installed sensor cover. The Notifier InnovairFlex housing provides a 3/4-inch conduit knockout and ample space to facilitate easy wiring and mounting of a relay module.

The Notifier InnovairFlex duct smoke detector can be customized to meet local codes and specifications without additional wiring. The new InnovairFlex product line is compatible with all previous Innovair models, including remote test accessories.

Features

- Photoelectric, integrated low-flow technology
- Air velocity rating from 100 ft/min to 4,000 ft/min (0.5 m/s to 20.32 m/s)
- Versatile mounting options: square or rectangular configuration
- Broad ranges for operating temperature (-4F to 158F) and humidity (0% to 95% non-condensing)
- Patented sampling tube installs from front or back of the detector with no tools required
- Cover tamper signal
- Increased wiring space with a newly added 3/4" conduit knockout
- Available space within housing to accommodate mounting of a relay module
- Easily accessible code wheels on sensor head (sold separately)
- Clear cover for convenient visual inspection
- Remote testing capability
- Requires com line power only
- Accommodates the installation of an addressable relay module, sold separately, (FRM-1 or NC-100R) for applications requiring a Form-C relay

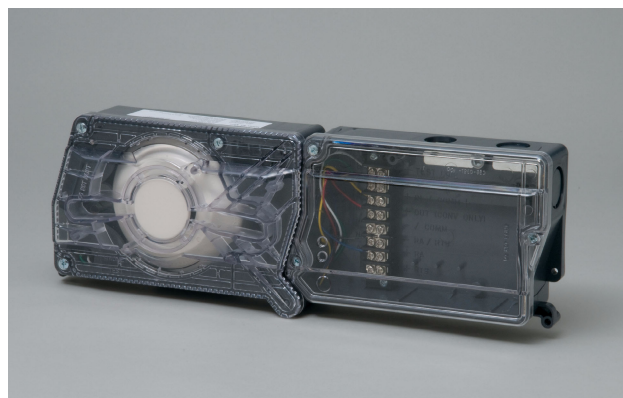

Specifications

Size: (Rectangle) 14.38 in (37 cm) Length; 5 in (12.7 cm) Width, 2.5 in (6.6 cm) Depth

Size: (Square) 7.75 in (19.7 cm) Length; 9 in (22.9 cm) Width; 2.5 in (6.35 cm) Depth

Weight: 1.6 lb (0.73 kg)

Operating Temperature Range: -4 degrees F to 158 degrees F (-20 degrees C to 70 degrees C)

Storage Temperature Range: -22 degrees F to 158 degrees F (-30 degrees C to 70 degrees C)

Operating Humidity Range: 0% to 95% relative humidity (non-condensing)

Air Duct Velocity: 100 to 4,000 ft/min (0.5 to 20.32 m/s)

Accessories

Notifier provides system flexibility with a variety of accessories, including two remote test stations and different means of visible and audible system annunciation. As with our duct smoke detectors, all duct smoke detector accessories are UL listed.

DNR(W)s with a date code of 0013 or higher do not require external 24VDC for remote test applications when used with a remote-test-capable detector.

ACCESSORY CURRENT LOADS AT 24 VDC

Device	Standby	Alarm
RA100Z	0mA	12 mA Max
RTS151/ RTS151KEY	0mA	12mA Max

Agency Listings and Approvals

Consult product manual for lists of compatible UL-Listed devices. In some cases, certain modules may not be listed by certain approval agencies, or listing may be in process. Consult factory for latest listing status.

- UL Listed: S911
- ULC Listed: S911
- CFSM Listed: 3242-1653:209

Product Line Information

NOTE: "A or "CDN" suffix indicates ULC listed model.

DNR(A): Intelligent non-relay photoelectric low flow smoke detector housing. Requires photoelectric smoke detector (sold separately).

DNRW: Watertight intelligent non-relay photoelectric low flow duct smoke detector housing. Requires photoelectric smoke detector (sold separately). NEMA-4.

FSP-851: Addressable low-profile photoelectric smoke detector.

FSP-851R: Remote test capable addressable low-profile photoelectric smoke detector.

NP-100: Addressable low-profile photoelectric smoke detector for FireWarden series panels.

NP-100R: Remote test capable addressable low-profile photoelectric smoke detector for FireWarden series panels.

DCOIL: Remote test coil. Required for older DNR(W) duct detector housing.

DST1(A): Metal sampling tube duct width up to 1 ft (0.3m)

DST1.5(A): Metal sampling tube duct widths up to 1 ft to 2 ft (0.3 to 0.6 m)

DST3(A): Metal sampling tube duct widths up to 2 ft to 4 ft (0.6 to 1.2 m)

DST5(A): Metal sampling tube duct widths up to 4 ft to 8 ft (1.2 to 2.4 m)

DST10(A): Metal sampling tube duct widths up to 8 ft to 12 ft (2.4 to 3.7 m)

DH400OE-1: Weatherproof enclosure

ETX: Metal exhaust tube duct, width 1 ft (0.3 m)

M02-04-00: Test magnet

P48-21-00: End cap for metal sampling tubes

RA100Z(A): Remote annunciator alarm LED

RTS151(A): Remote test station

RTS151KEY(A): Remote test station with key lock

Important Note

- DNRW duct detector housings with a date code of 0013 or higher do not require a DCOIL or auxiliary 24 VDC for remote test applications when used with a remote test capable detector.
- DNRW duct detector housings with a date code of 0012 or earlier require a DCOIL and auxiliary 24 VDC power for remote test applications.

ONYX® and NOTIFIER® are registered trademarks and NOTI•FIRE•NET™ is a trademark of Honeywell International Inc. ©2010 by Honeywell International Inc. All rights reserved. Unauthorized use of this document is strictly prohibited.



This document is not intended to be used for installation purposes.
We try to keep our product information up-to-date and accurate.
We cannot cover all specific applications or anticipate all requirements.
All specifications are subject to change without notice.



Made in the U.S. A.

For more information, contact Notifier. Phone: (203) 484-7161, FAX: (203) 484-7118.
www.notifier.com

FST-851(A) Series

Intelligent Thermal (Heat) Detectors with FlashScan®



Intelligent / Addressable Devices

General

Notifier FST-851(A) Series intelligent plug-in thermal detectors with integral communication has features that surpass conventional detectors. Point ID capability allows each detector's address to be set with rotary, decimal address switches, providing exact detector locations. FST-851(A) Series thermal detectors use an innovative thermistor sensing circuit to produce 135°F/57°C fixed-temperature (FST-851/A) and rate-of-rise thermal detection (FST-851R/A) in a low-profile package. FST-851H(A) provides fixed high-temperature detection at 190°F/88°C. These thermal detectors provide effective, intelligent property protection in a variety of applications. FST-851(A) Series detectors are compatible with Notifier Onyx and CLIP series Fire Alarm Control Panels (FACPs).

FlashScan® (U.S. Patent 5,539,389) is a communication protocol developed by Notifier Engineering that greatly enhances the speed of communication between analog intelligent devices and certain NOTIFIER systems. Intelligent devices communicate in a grouped fashion. If one of the devices within the group has new information, the panel's CPU stops the group poll and concentrates on single points. The net effect is response speed greater than five times that of earlier designs.

Features

- Sleek, low-profile, stylish design.
- State-of-the-art thermistor technology for fast response.
- Rate-of-rise model (FST-851R/A), 15°F (8.3°C) per minute.
- Factory preset fixed temperature at 135°F (57°C); high-temperature model fixed at 190°F (88°C).
- Addressable by device.
- Compatible with FlashScan® and CLIP protocol systems.
- Rotary, decimal addressing (1-99 on CLIP systems, 1-159 on FlashScan systems).
- Two-wire SLC connection.
- Visible LEDs "blink" every time the unit is addressed.
- 360°-field viewing angle of the visual alarm indicators (two bi-color LEDs). LEDs blink green in Normal condition and turn on steady red in Alarm.
- Integral communications and built-in device-type identification.
- Remote test feature from the panel.
- Built-in functional test switch activated by external magnet.
- Walk test with address display (an address of 121 will blink the detector LED 12-(pause)-1).
- Low standby current.
- Backward-compatible.
- Built-in tamper-resistant feature.
- Designed for direct-surface or electrical-box mounting.
- Sealed against back pressure.
- Plugs into separate base for ease of installation and maintenance. Separate base allows interchange of photoelectric, ionization and thermal sensors.
- SEMS screws for wiring of the separate base.
- Constructed of off-white fire-resistant plastic, designed to commercial standards, and offers an attractive appearance.



FST-851(A) in B210LP(A) Base

B210-2251.jpg

- 94-5V plastic flammability rating.
- Remote LED output connection to optional RA100Z(A) remote LED annunciator.
- Optional sounder, relay, and isolator bases.
- Optional flanged surface mounting kit.

Specifications

Size: 2.1" (5.3 cm) high; base determines diameter.

- B210LP(A): 6.1" (15.5 cm) diameter.
- B501(A): 4.1" (10.4 cm) diameter.
- B200S(A): 6.875" (17.46 cm) diameter.
- B200SR(A): 6.875" (17.46 cm) diameter.
- B224RB(A): 6.2" (15.748 cm) diameter.
- B224BI(A): 6.2" (15.748 cm) diameter.

Shipping weight: 4.8 oz. (137 g).

Operating temperature range: FST-851(A) Series, FST-851R(A): -20°C to 38°C (-4°F to 100°F); FST-851H(A): -20°C to 66°C (-4°F to 150°F).

Detector spacing: UL approved for 50 ft. (15.24 m) center to center. FM approved for 25 x 25 ft. (7.62 x 7.62 m) spacing.

Relative humidity: 10% – 93% noncondensing.

Thermal ratings: fixed-temperature setpoint 135°F (57°C), rate-of-rise detection 15°F (8.3°C) per minute, high temperature heat 190°F (88°C).

ELECTRICAL SPECIFICATIONS

Voltage range: 15 - 32 volts DC peak.

Standby current (max. avg.): 300 µA @ 24 VDC (one communication every 5 seconds with LED enabled).

LED current (max.): 6.5 mA @ 24 VDC ("ON").

Applications

Use thermal detectors for protection of property. For further information, go to systemsensor.com for manual I56-407-00, Applications Manual for System Smoke Detectors, which provides detailed information on detector spacing, placement, zoning, wiring, and special applications.

Installation

The FST Series plug-in intelligent thermal detectors use a separate base to simplify installation, service, and maintenance. Installation instructions are shipped with each detector. A special tool allows maintenance personnel to plug in and remove detectors without using a ladder.

Mount base (all base types) on an electrical backbox which is at least 1.5" (3.81 cm) deep. For a chart of compatible junction boxes, see *DN-60054*.

NOTE: 1) Because of the inherent supervision provided by the SLC loop, end-of-line resistors are not required. Wiring "T-taps" or branches are permitted for Style 4 (Class "B") wiring. **2)** When using relay or sounder bases, consult the ISO-X(A) installation sheet 156-1380 for device limitations between isolator modules and isolator bases.

Agency Listings and Approvals

These listings and approvals apply to the modules specified in this document. In some cases, certain modules or applications may not be listed by certain approval agencies, or listing may be in process. Consult factory for latest listing status.

- **UL Listed:** S747.
- **ULC Listed:** S6978.
- **MEA Listed:** 383-02-E.
- **FM Approved.**
- **CSFM:** 7270-0028:0196.
- **BSMI:** CI313066760025.
- **CCCF:** Certif. # 2004081801000018.
- **U.S. Coast Guard:** 161.002/42/1 (NFS-640); 161.002/50/0 (NFS2-640/NFS-320/NFS-320C, excluding B210LP(A)).
- **Lloyd's Register:** 11/600013 (NFS2-640/NFS-320/NFS-320C, excluding B210LP(A)).

Product Line Information

NOTE: "A" suffix indicates ULC Listed model.

FST-851: Intelligent thermal detector. Must be mounted to one of the bases listed below.

FST-851A: Same as FST-851 but with ULC Listing.

FST-851R: Intelligent thermal detector with rate-of-rise feature.

FST-851RA: Same as FST-851R but with ULC Listing.

FST-851H: Intelligent high-temperature thermal detector.

FST-851HA: Same as FST-851H but with ULC Listing.

INTELLIGENT BASES

NOTE: "A" suffix indicates ULC Listed model.

NOTE: For details about intelligent bases and their mounting, see *DN-60054*.

B210LP(A): Standard U.S. flanged low-profile mounting base.

B210LPBP: Bulk pack of B210LP; package contains 10.

B501(A): Standard European flangeless mounting base.

B501BP: Bulk pack of B501; package contains 10.

B200S(A): Addressable Intelligent, programmable sounder base capable of producing sound output in high or low volume

with ANSI Temporal 3, ANSI Temporal 4, continuous tone, marching tone, and custom tone.

B200SR(A): Intelligent sounder base capable of producing sound output with ANSI Temporal 3 or continuous tone. Replaces B501BH series bases in retrofit applications.

B224RB(A): Intelligent relay base. Screw terminals: up to 14 AWG (2.0 mm²). Relay type: Form-C. Rating: 2.0 A @ 30 VDC resistive; 0.3 A @ 110 VDC inductive; 1.0 A @ 30 VDC inductive.

B224BI(A): Intelligent isolator base. Isolates SLC from loop shorts. Maximum: 25 devices between isolator bases; see Note 2 under Installation.

ACCESSORIES

F110: Retrofit flange to convert B210LP(A) to match the B710LP(A) profile, or to convert older high-profile bases to low-profile.

F110BP: Bulk pack of F110; package contains 15.

F210: Replacement flange for B210LP(A) base.

RA100Z(A): Remote LED annunciator. 3 – 32 VDC. Fits U.S. single-gang electrical box. Supported by B210LP(A) and B501(A) bases only.

SMB600: Surface mounting kit, flanged.

M02-04-00: Test magnet.

M02-09-00: Test magnet with telescoping handle.

XR2B: Detector removal tool. Allows installation and/or removal of FlashScan® Series detector heads from base in high ceiling installations. Includes T55-127-010.

T55-127-010: Detector removal tool without pole.

XP-4: Extension pole for XR2B. Comes in three 5-foot (1.524 m) sections.

Notifier® and FlashScan® are registered trademarks of Honeywell International Inc.

©2011 by Honeywell International Inc. All rights reserved. Unauthorized use of this document is strictly prohibited.



This document is not intended to be used for installation purposes.
We try to keep our product information up-to-date and accurate.
We cannot cover all specific applications or anticipate all requirements.
All specifications are subject to change without notice.



For more information, contact Notifier. Phone: (203) 484-7161, FAX: (203) 484-7118.
www.notifier.com

FMM-1, FMM-101, FZM-1 & FDM-1

Monitor Modules with FlashScan®



Intelligent/Addressable Devices

General

Four different monitor modules are available for Notifier's intelligent control panels to suit a variety of applications. Monitor modules are used to supervise a circuit of dry-contact input devices, such as conventional heat detectors and pull stations, or monitor and power a circuit of two-wire smoke detectors (FZM-1).

FMM-1 is a standard-sized module (typically mounts to a 4" [10.16 cm] square box) that supervises either a Class A (Style D) or Class B (Style B) circuit of dry-contact input devices.

FMM-101 is a miniature monitor module (a mere 1.3" (3.302 cm) H x 2.75" (6.985 cm) W x 0.5" (1.270 cm) D) used to supervise a Class B (Style B) circuit of dry-contact input devices. Its compact design allows the FMM-101 to often be mounted in a single-gang box behind the device it monitors.

FZM-1 is a standard-sized module used to monitor and supervise compatible two-wire, 24 volt, smoke detectors on a Class A (Style D) or Class B (Style B) circuit.

FDM-1 is a standard-sized dual monitor module used to monitor and supervise two independent two-wire Style B (Class B) dry-contact initiating device circuits (IDCs) at two separate, consecutive addresses in intelligent, two-wire systems.

FlashScan® (U.S. Patent 5,539,389) is a communication protocol developed by NOTIFIER Engineering that greatly enhances the speed of communication between analog intelligent devices. Intelligent devices communicate in a grouped fashion. If one of the devices within the group has new information, the panel CPU stops the group poll and concentrates on single points. The net effect is response speed greater than five times that of other designs.

FMM-1 Monitor Module

- Built-in type identification automatically identifies this device as a monitor module to the control panel.
- Powered directly by two-wire SLC loop. No additional power required.
- High noise (EMF/RFI) immunity.
- SEMS screws with clamping plates for ease of wiring.
- Direct-dial entry of address: 01 – 159 on FlashScan systems, 01 – 99 on CLIP systems.
- LED flashes green during normal operation (this is a programmable option) and latches on steady red to indicate alarm.

The FMM-1 Monitor Module is intended for use in intelligent, two-wire systems, where the individual address of each module is selected using the built-in rotary switches. It provides either a two-wire or four-wire fault-tolerant Initiating Device Circuit (IDC) for normally-open-contact fire alarm and supervisory devices. The module has a panel-controlled LED indicator. The FMM-1 can be used to replace MMX-1 modules in existing systems.

FMM-1 APPLICATIONS

Use to monitor a zone of four-wire smoke detectors, manual fire alarm pull stations, waterflow devices, or other normally-open dry-contact alarm activation devices. May also be used to monitor normally-open supervisory devices with special supervisory indication at the control panel. Monitored circuit

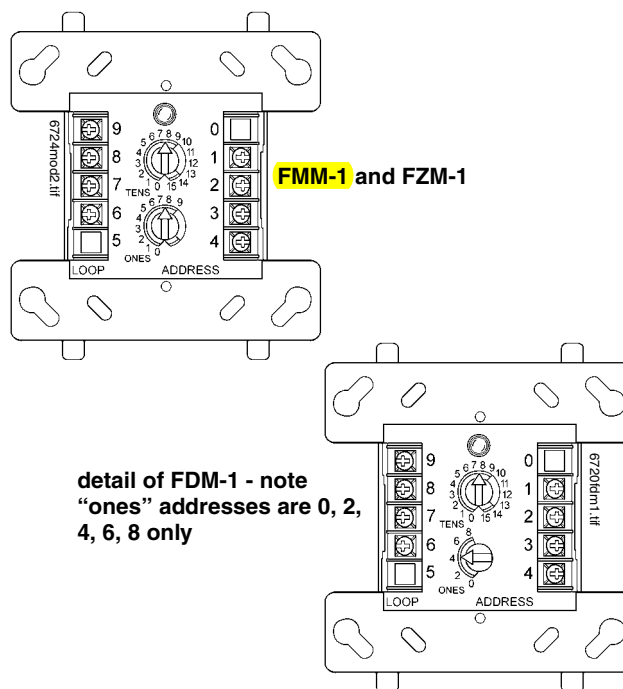

may be wired as an NFPA Style B (Class B) or Style D (Class A) Initiating Device Circuit. A 47K ohm End-of-Line Resistor (provided) terminates the Style B circuit. No resistor is required for supervision of the Style D circuit.

FMM-1 OPERATION

Each FMM-1 uses one of the available module addresses on an SLC loop. It responds to regular polls from the control panel and reports its type and the status (open/normal/short) of its Initiating Device Circuit (IDC). A flashing LED indicates that the module is in communication with the control panel. The LED latches steady on alarm (subject to current limitations on the loop).

FMM-1 SPECIFICATIONS

Nominal operating voltage: 15 to 32 VDC.

Maximum current draw: 5.1 mA (LED on).

Maximum operating current: 375 μ A (LED flashing).

Maximum IDC wiring resistance: 1,500 ohms.

EOL resistance: 47K ohms.

Temperature range: 32°F to 120°F (0°C to 49°C).

Humidity range: 10% to 93% noncondensing.

Dimensions: 4.5" (11.43 cm) high x 4" (10.16 cm) wide x 1.25" (3.175 cm) deep. Mounts to a 4" (10.16 cm) square x 2.125" (5.398 cm) deep box.

FMM-101 Mini Monitor Module

- Built-in type identification automatically identifies this device as a monitor module to the panel.

- Powered directly by two-wire FACP. No additional power required.
- High noise (EMF/RFI) immunity.
- Tinned, stripped leads for ease of wiring.
- Direct-dial entry of address: 01 – 159 on FlashScan systems, 01 – 99 on CLIP systems.

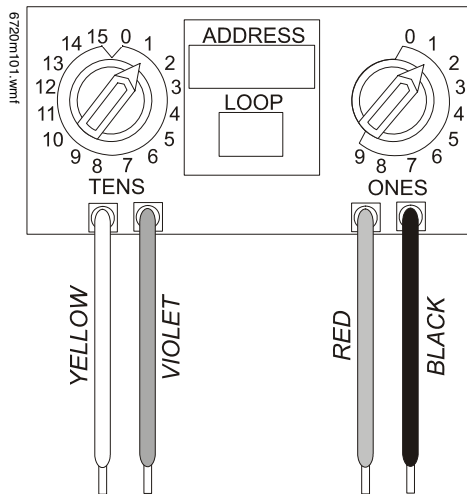

The FMM-101 Mini Monitor Module can be installed in a single-gang junction directly behind the monitored unit. Its small size and light weight allow it to be installed without rigid mounting. The FMM-101 is intended for use in intelligent, two-wire systems where the individual address of each module is selected using rotary switches. It provides a two-wire initiating device circuit for normally-open-contact fire alarm and security devices. The FMM-101 can be used to replace MMX-101 modules in existing systems.

FMM-101 APPLICATIONS

Use to monitor a single device or a zone of four-wire smoke detectors, manual fire alarm pull stations, waterflow devices, or other normally-open dry-contact devices. May also be used to monitor normally-open supervisory devices with special supervisory indication at the control panel. Monitored circuit/device is wired as an NFPA Style B (Class B) Initiating Device Circuit. A 47K ohm End-of-Line Resistor (provided) terminates the circuit.

FMM-101 OPERATION

Each FMM-101 uses one of the available module addresses on an SLC loop. It responds to regular polls from the control panel and reports its type and the status (open/normal/short) of its Initiating Device Circuit (IDC).

FMM-101 SPECIFICATIONS

- Nominal operating voltage:** 15 to 32 VDC.
- Maximum operating current:** 375 μ A.
- Maximum IDC wiring resistance:** 1,500 ohms.
- EOL resistance:** 47K ohms.
- Temperature range:** 32°F to 120°F (0°C to 49°C).
- Humidity range:** 10% to 93% noncondensing.
- Dimensions:** 1.3" (3.302 cm) high x 2.75" (6.985 cm) wide x 0.65" (1.651 cm) deep.
- Wire length:** 6" (15.24 cm) minimum.

FZM-1 Interface Module

- Supports compatible two-wire smoke detectors.
- Supervises IDC wiring and connection of external power source.
- High noise (EMF/RFI) immunity.
- SEMS screws with clamping plates for ease of wiring.
- Direct-dial entry of address: 01 – 159 on FlashScan systems, 01 – 99 on CLIP systems.
- LED flashes during normal operation; this is a programmable option.
- LED latches steady to indicate alarm on command from control panel.

The FZM-1 Interface Module is intended for use in intelligent, addressable systems, where the individual address of each module is selected using built-in rotary switches. This module allows intelligent panels to interface and monitor two-wire conventional smoke detectors. It transmits the status (normal, open, or alarm) of one full zone of conventional detectors back to the control panel. All two-wire detectors being monitored must be UL compatible with the module. The FZM-1 can be used to replace MMX-2 modules in existing systems.

FZM-1 APPLICATIONS

Use the FZM-1 to monitor a zone of two-wire smoke detectors. The monitored circuit may be wired as an NFPA Style B (Class B) or Style D (Class A) Initiating Device Circuit. A 3.9 K ohm End-of-Line Resistor (provided) terminates the end of the Style B or D (class B or A) circuit (maximum IDC loop resistance is 25 ohms). Install ELR across terminals 8 and 9 for Style D application.

FZM-1 OPERATION

Each FZM-1 uses one of the available module addresses on an SLC loop. It responds to regular polls from the control panel and reports its type and the status (open/normal/short) of its Initiating Device Circuit (IDC). A flashing LED indicates that the module is in communication with the control panel. The LED latches steady on alarm (subject to current limitations on the loop).

FZM-1 SPECIFICATIONS

- Nominal operating voltage:** 15 to 32 VDC.
- Maximum current draw:** 5.1 mA (LED on).
- Maximum IDC wiring resistance:** 25 ohms.
- Maximum operating current:** 270 μ A (LED flashing).
- EOL resistance:** 3.9K ohms.
- External supply voltage (between Terminals T3 and T4):** DC voltage: 24 volts power limited. Ripple voltage: 0.1 Vrms maximum. Current: 90 mA per module maximum.
- Temperature range:** 32°F to 120°F (0°C to 49°C).
- Humidity range:** 10% to 93% noncondensing.
- Dimensions:** 4.5" (11.43 cm) high x 4" (10.16 cm) wide x 1.25" (3.175 cm) deep. Mounts to a 4" (10.16 cm) square x 2.125" (5.398 cm) deep box.

FDM-1 Dual Monitor Module

The FDM-1 Dual Monitor Module is intended for use in intelligent, two-wire systems. It provides two independent two-wire initiating device circuits (IDCs) at two separate, consecutive addresses. It is capable of monitoring normally open contact fire alarm and supervisory devices; or either normally open or normally closed security devices. The module has a single panel-controlled LED.

NOTE: The FDM-1 provides two Class B (Style B) IDC circuits ONLY. Class A (Style D) IDC circuits are NOT supported in any application.

FDM-1 SPECIFICATIONS

Normal operating voltage range: 15 to 32 VDC.

Maximum current draw: 6.4 mA (LED on).

Maximum operating current: 750 μ A (LED flashing).

Maximum IDC wiring resistance: 1,500 ohms.

EOL resistance: 47K ohms.

Temperature range: 32° to 120°F (0° to 49°C).

Humidity range: 10% to 93% (non-condensing).

Dimensions: 4.5" (11.43 cm) high x 4" (10.16 cm) wide x 2.125" (5.398 cm) deep.

FDM-1 AUTOMATIC ADDRESSING

The FDM-1 automatically assigns itself to two addressable points, starting with the original address. For example, if the FDM-1 is set to address "26", then it will automatically assign itself to addresses "26" and "27".

NOTE: "Ones" addresses on the FDM-1 are 0, 2, 4, 6, or 8 only. Terminals 6 and 7 use the first address, and terminals 8 and 9 use the second address.



CAUTION:

Avoid duplicating addresses on the system.

Installation

FMM-1, FZM-1, and FDM-1 modules mount directly to a standard 4" (10.16 cm) square, 2.125" (5.398 cm) deep, electrical box. They may also be mounted to the SMB500 surface-mount box. Mounting hardware and installation instructions are provided with each module. All wiring must conform to applicable local codes, ordinances, and regulations. These modules are intended for power-limited wiring only.

The FMM-101 module is intended to be wired and mounted without rigid connections inside a standard electrical box. All wiring must conform to applicable local codes, ordinances, and regulations.

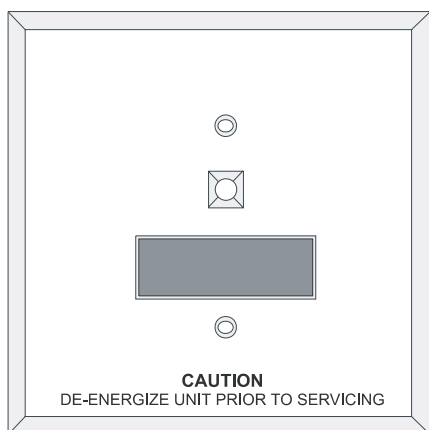

Face plate for FMM-1, FZM-1, and FDM-1

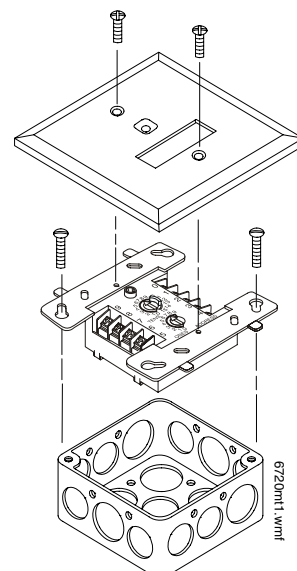
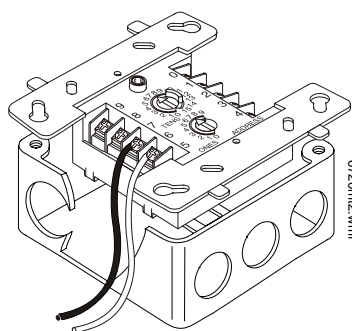

Mounting Diagrams for Standard-sized Modules

Agency Listings and Approvals

In some cases, certain modules may not be listed by certain approval agencies, or listing may be in process. Consult factory for latest listing status.

- **UL:** S635
- **ULC:** S3705
- **FM Approved**
- **CSFM:** 7300-0028:202
- **MEA:**
 - 143-01-E (FDM-1)
 - 317-01-E (FMM-1/-101)
 - 345-02-E (FMM-1/-101)
 - 457-99-E (FZM-1, FMM-1/-101)
 - 447-99-E (FMM-1/-101, FZM-1)
 - 232-06-E (FZM-1, FMM-1/-101)
 - 128-07-E (FZM-1, FMM-1/101)
- **U.S. Coast Guard:**
 - 161.002/23/3 (AFP-200: FMM-1/-101, FZM-1)
 - 161.002/42/1 (NFS-640: FMM-1/-101)
- **Lloyd's Register:**
 - 03/60011/E1 (FMM-1/-101, FZM-1)
 - 94/60004/E2 (AFP-200: except FDM-1)
 - 02/60007 (NFS-640: FDM-1)
 - 07/60007 (NFS2-3030: all)

Product Line Information

NOTE: "A" suffix indicates ULC Listed model.

FMM-1(A): Monitor module.

FMM-101(A): Monitor module, miniature.

FZM-1(A): Monitor module, two-wire detectors

FDM-1(A): Monitor module, dual, two independent Class B circuits.

SMB500: Optional surface-mount backbox.

Architects'/Engineers' Specifications

Specifications of these and all Notifier products are available from Notifier.

Wiring Diagrams

The following wiring diagrams are included:

1. **FDM-1:** Typical dual two-wire Style B initiating device circuit configuration.
2. **FMM-101:** Typical two-wire Style B initiating device circuit configuration.
3. **FMM-1:** Typical two-wire initiating circuit configuration, NFPA Style B.
4. **FMM-1:** Typical four-wire fault-tolerant initiating circuit configuration, NFPA Style D.
5. **FMM-1:** Typical two-wire initiating circuit configuration for security systems (with alarm versus short capability).
6. **FZM-1:** Interface two-wire conventional detectors, NFPA Style B.
7. **FZM-1:** Interface two-wire conventional detectors, NFPA Style D.
8. Applications with Conventional Detectors: Resetting Conventional Detectors

Figure 1 FDM-1: Typical dual two-wire Style B initiating device circuit configuration.

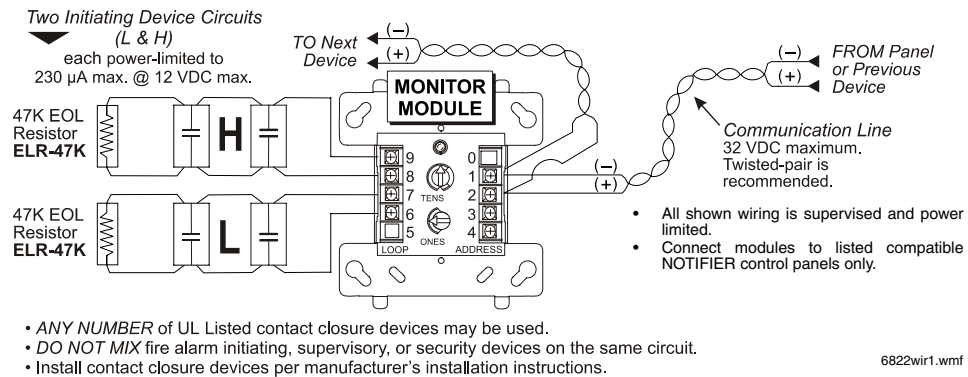
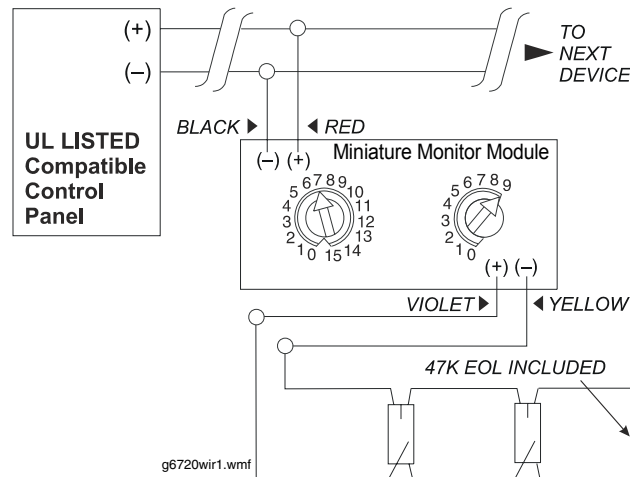

Figure 2 FMM-101: Typical two-wire Style B initiating device circuit configuration.



NOTE: Wiring Diagrams this Page: FMM-1

- Connect modules to listed compatible NOTIFIER control panels only.
- All wiring shown is supervised and power limited.
- Install contact closure devices per manufacturers' installation instructions.
- Any number of UL-listed contact closure devices may be used.
- DO NOT MIX fire alarm initiating, supervisory, and security devices on the same circuit.

Figure 3 FMM-1: Typical two-wire initiating circuit configuration, NFPA Style B.

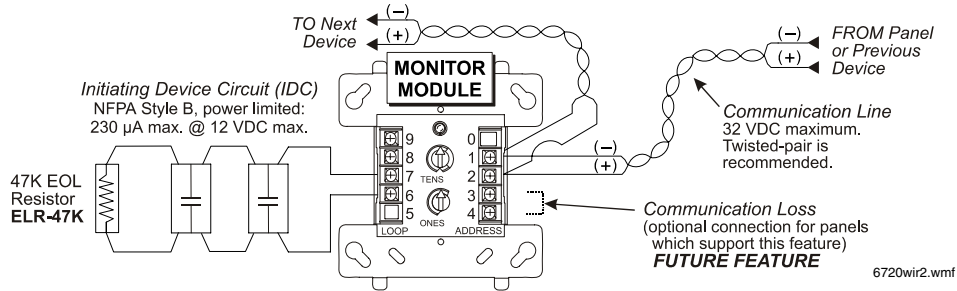

Figure 4 FMM-1: Typical four-wire fault-tolerant initiating circuit configuration, NFPA Style D.

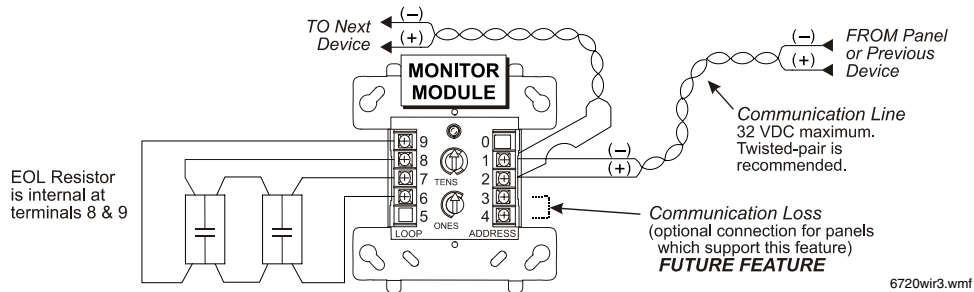
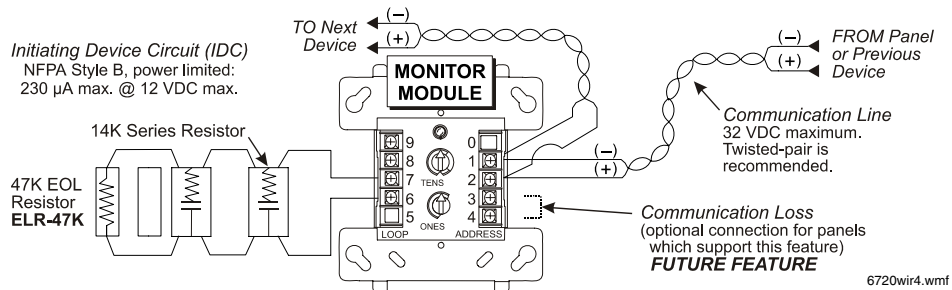

Figure 5 FMM-1: Typical two-wire initiating circuit configuration for security systems (with alarm versus short capability).



NOTE: Wiring Diagrams this Page: FZM-1 and FRM-1

- Connect modules to listed compatible control panels only.
- Terminal wiring must be power limited.
- DO NOT MIX fire alarm initiating, supervisory, and security devices on the same circuit.
- DO NOT LOOP wire under terminals. Break wire run to provide supervision of connections.
- Detectors must be UL listed compatible with module.
- Install detectors per manufacturers' installation instructions.
- Power to the interface module must be externally switched to reset the detectors. An FRM-1 relay control module can be used to switch power from a standard power supply; see Figure 8 below.

Figure 6 FZM-1: Interface two-wire conventional detectors, NFPA Style B.

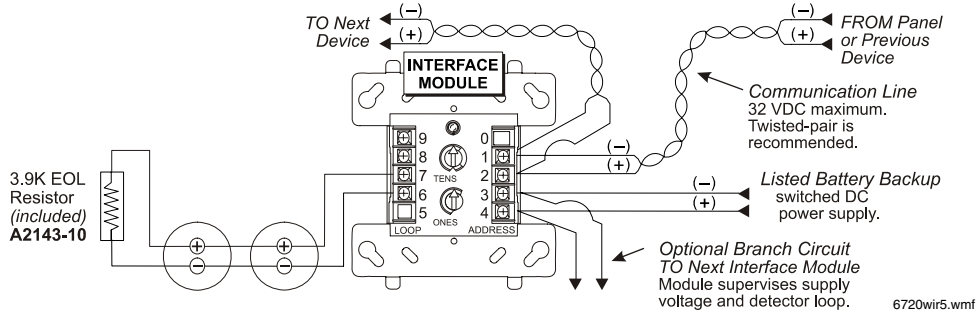

Figure 7 FZM-1: Interface two-wire conventional detectors, NFPA Style D.

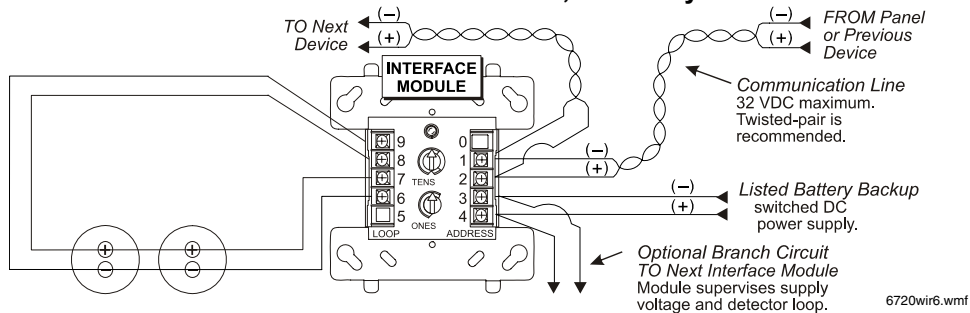
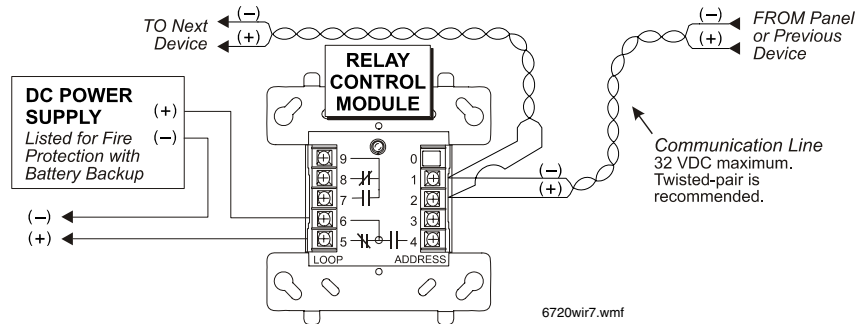

Figure 8 Applications with Conventional Detectors: Resetting detectors

NOTE: To reset conventional detectors, externally switch off power to the interface module they are connected to. This example shows FRM-1 (see DN-6724).



Notifier® and FlashScan® are registered trademarks of Honeywell International Inc.
 ©2008 by Honeywell International Inc. All rights reserved. Unauthorized use of this document is strictly prohibited.



This document is not intended to be used for installation purposes.
 We try to keep our product information up-to-date and accurate.
 We cannot cover all specific applications or anticipate all requirements.
 All specifications are subject to change without notice.



For more information, contact Notifier. Phone: (203) 484-7161, FAX: (203) 484-7118.
www.notifier.com

FCM-1(A) & FRM-1(A) Series

Control and Relay Modules



Intelligent / Addressable Devices

General

FCM-1(A) Control Module: The FCM-1(A) Addressable Control Module provides Notifier intelligent fire alarm control panels a circuit for Notification Appliances (horns, strobes, speakers, etc.) Addressability allows the FCM-1(A) to be activated, either manually or through panel programming, on a select (zone or area of coverage) basis.

FRM-1(A) Relay Module: The FRM-1(A) Addressable Relay Module provides the system with a dry-contact output for activating a variety of auxiliary devices, such as fans, dampers, control equipment, etc. Addressability allows the dry contact to be activated, either manually or through panel programming, on a select basis.

FlashScan® (U.S. Patent 5,539,389) is a communication protocol developed by NOTIFIER Engineering that greatly enhances the speed of communication between analog intelligent devices. Intelligent devices communicate in a grouped fashion. If one of the devices within the group has new information, the panel CPU stops the group poll and concentrates on single points. The net effect is response speed greater than five times that of other designs.

Features

- Built-in type identification automatically identifies these devices to the control panel.
- Internal circuitry and relay powered directly by two-wire SLC loop. The FCM-1(A) module requires power (for horns, strobes, etc.), or audio (for speakers).
- Integral LED “blinks” green each time a communication is received from the control panel and turns on in steady red when activated.
- LED blink may be deselected globally (affects all devices).
- High noise immunity (EMF/RFI).
- The FCM-1(A) may be used to switch 24-volt NAC power, audio (up to 70.7 Vrms).
- Wide viewing angle of LED.
- SEMS screws with clamping plates for wiring ease.
- Direct-dial entry of address 01– 159 for FlashScan loops, 01 – 99 for CLIP mode loops.
- Speaker, and audible/visual applications may be wired for Class B or A (Style Y or Z).

Applications

The FCM-1(A) is used to switch 24 VDC audible/visual power, high-level audio (speakers), or control telephone devices. The FRM-1(A) may be programmed to operate dry contacts for applications such as door holders or Air Handling Unit shut-down, and to reset four-wire smoke detector power.

NOTE: Refer to the SLC Manual (PN 51253) for details regarding releasing applications with the FCM-1(A). Refer to the FCM-1-REL datasheet (DN-60390) for new FlashScan® releasing applications.

Construction

- The face plate is made of off-white heat-resistant plastic.
- Controls include two rotary switches for direct-dial entry of address (01-159).



FCM-1(A)

- The FCM-1(A) is configured for a single Class B (Style Y) or Class A (Style Z) Notification Appliance Circuit.
- The FRM-1(A) provides two Form-C dry contacts that switch together.

Operation

Each FCM-1(A) or FRM-1(A) uses one of 159 possible module addresses on a SLC loop (99 on CLIP loops). It responds to regular polls from the control panel and reports its type and status, including the open/normal/short status of its Notification Appliance Circuit (NAC). The LED blinks with each poll received. On command, it activates its internal relay. The FCM-1(A) supervises Class B (Style Y) or Class A (Style Z) notification or control circuits.

Upon code command from the panel, the FCM-1(A) will disconnect the supervision and connect the external power supply in the proper polarity across the load device. The disconnection of the supervision provides a positive indication to the panel that the control relay actually turned ON. The external power supply is always relay isolated from the communication loop so that a trouble condition on the external power supply will never interfere with the rest of the system.

Rotary switches set a unique address for each module. The address may be set before or after mounting. The built-in TYPE CODE (not settable) will identify the module to the control panel, so as to differentiate between a module and a sensor address.

Specifications for FCM-1(A)

Normal operating voltage: 15 to 32 VDC.

Maximum current draw: 6.5 mA (LED on).

Average operating current: 350 μ A direct poll, 375 μ A group poll with LED flashing, 485 μ A Max. (LED flashing, NAC shorted.)

Maximum NAC Line Loss: 4 VDC.

External supply voltage (between Terminals T10 and T11): Maximum (NAC): Regulated 24 VDC; Maximum (Speakers): 70.7 V RMS, 50W.

Drain on external supply: 1.7 mA maximum using 24 VDC supply; 2.2 mA Maximum using 80 VRMS supply.

Max NAC Current Ratings: For class B wiring system, the current rating is 3A; For class A wiring system, the current rating is 2A.

Temperature range: 32°F to 120°F (0°C to 49°C).

Humidity range: 10% to 93% non-condensing.

Dimensions: 4.5" (114.3 mm) high x 4" (101.6 mm) wide x 1.25" (31.75 mm) deep. Mounts to a 4" (101.6 mm) square x 2.125" (53.975 mm) deep box.

Accessories: SMB500 Electrical Box; CB500 Barrier

Specifications for FRM-1(A)

Normal operating voltage: 15 to 32 VDC.

Maximum current draw: 6.5 mA (LED on).

Average operating current: 230 µA direct poll; 255 µA group poll.

EOL resistance: not used.

Temperature range: 32°F to 120°F (0°C to 49°C).

Humidity range: 10% to 93% non-condensing.

Dimensions: 4.5" (114.3 mm) high x 4" (101.6 mm) wide x 1.25" (31.75 mm) deep. Mounts to a 4" (101.6 mm) square x 2.125" (53.975 mm) deep box.

Accessories: SMB500 Electrical Box; CB500 Barrier

Agency Listings and Approvals

In some cases, certain modules may not be listed by certain approval agencies, or listing may be in process. Consult factory for latest listing status.

- **UL:** S635
- **ULC:** S7557 (A version only)
- **FM Approved**
- **CSFM:** 7300-0028:202
- **MEA:** 14-00-E

Contact Ratings for FRM-1(A)

Current Rating	Maximum Voltage	Load Description	Application
3 A	30 VDC	Resistive	Non-Coded
2 A	30 VDC	Resistive	Coded
.9 A	110 VDC	Resistive	Non-Coded
.9 A	125 VDC	Resistive	Non-Coded
.5 A	30 VDC	Inductive (L/R=5ms)	Coded
1 A	30 VDC	Inductive (L/R=2ms)	Coded
.3 A	125 VDC	Inductive (PF=0.35)	Non-Coded
1.5 A	25 VDC	Inductive (PF=0.35)	Non-Coded
.7 A	70.7 VDC	Inductive (PF=0.35)	Non-Coded
2 A	25 VDC	Inductive (PF=0.35)	Non-Coded

NOTE: Maximum (Speakers): 70.7 V RMS, 50 W

Product Line Information

NOTE: "A" suffix indicates ULC Listed model.

FCM-1(A): Intelligent Addressable Control Module.

FRM-1(A): Intelligent Addressable Relay Module.

A2143-20: Capacitor, required for Class A (Style Z) operation of speakers.

SMB500: Optional Surface-Mount Backbox.

CB500: Control Module Barrier — required by UL for separating power-limited and non-power limited wiring in the same junction box as FCM-1(A).

NOTE: For installation instructions, see the following documents:

- *FCM-1(A) Installation document I56-1169.*
- *FRM-1(A) Installation document I56-3502.*
- *Notifier SLC Wiring Manual, document 51253.*

Notifier® and FlashScan® are registered trademarks of Honeywell International Inc.

©2009 by Honeywell International Inc. All rights reserved. Unauthorized use of this document is strictly prohibited.



This document is not intended to be used for installation purposes.
We try to keep our product information up-to-date and accurate.
We cannot cover all specific applications or anticipate all requirements.
All specifications are subject to change without notice.



Made in the U.S. A.

For more information, contact Notifier. Phone: (203) 484-7161, FAX: (203) 484-7118.
www.notifier.com