

City of Portland, Maine - Building or Use Permit Application

389 Congress Street, 04101 Tel: (207) 874-8703, Fax: (207) 874-8716

PERMIT ISSUED FEB 25 2002 CITY OF PORTLAND		Permit No: 020134 Issue Date:	CBL: 275 C001001
Location of Construction: 977 Brighton Ave	Owner Name: Wise Investment Properties Inc	Owner Address: 36 Clearwater Dr	Phone: 207-772-1800
Business Name: n/a	Contractor Name: Burr Signs	Contractor Address: 10 Buffonwood St. So. Portland	Phone: 2077991183
Lessee/Buyer's Name: n/a	Phone: n/a	Permit Type: Signs - Permanent	Zone: R-P

Past Use: Commercial / Office	Proposed Use: Commercial / Office; Erect 6' x 5' Sign with 8" height.	Permit Fee:	Cost of Work: \$0.00	CEO District: 3
Proposed Project Description: Erect 6' x 5' Sign <i>only street address. Allowed below main sign age - see conditions</i>		FIRE DEPT: N/A <input type="checkbox"/> Approved <input checked="" type="checkbox"/> Denied	INSPECTION: Use Group: U Type: Sign BOCA 1999 Signature: J. Munro	
		PEDESTRIAN ACTIVITIES DISTRICT (P.A.D.) Action: <input type="checkbox"/> Approved <input type="checkbox"/> Approved w/Conditions <input type="checkbox"/> Denied Signature: _____ Date: _____		

Permit Taken By: gg	Date Applied For: 02/12/2002	Zoning Approval		
1. This permit application does not preclude the Applicant(s) from meeting applicable State and Federal Rules. 2. Building permits do not include plumbing, septic or electrical work. 3. Building permits are void if work is not started within six (6) months of the date of issuance. False information may invalidate a building permit and stop all work..		Special Zone or Reviews <input type="checkbox"/> Shoreland <input type="checkbox"/> Wetland <input type="checkbox"/> Flood Zone <input type="checkbox"/> Subdivision <input type="checkbox"/> Site Plan Maj <input type="checkbox"/> Minor <input type="checkbox"/> MM <input type="checkbox"/> Date: <i>02/19/02</i>	Zoning Appeal <input type="checkbox"/> Variance <input type="checkbox"/> Miscellaneous <input type="checkbox"/> Conditional Use <input type="checkbox"/> Interpretation <input type="checkbox"/> Approved <input type="checkbox"/> Denied Date: _____	Historic Preservation <input checked="" type="checkbox"/> Not in District or Landmark <input type="checkbox"/> Does Not Require Review <input type="checkbox"/> Requires Review <input type="checkbox"/> Approved <input type="checkbox"/> Approved w/Conditions <input type="checkbox"/> Denied Date: _____

CERTIFICATION

I hereby certify that I am the owner of record of the named property, or that the proposed work is authorized by the owner of record and that I have been authorized by the owner to make this application as his authorized agent and I agree to conform to all applicable laws of this jurisdiction. In addition, if a permit for work described in the application is issued, I certify that the code official's authorized representative shall have the authority to enter all areas covered by such permit at any reasonable hour to enforce the provision of the code(s) applicable to such permit.

SIGNATURE OF APPLICANT	ADDRESS	DATE	PHONE
RESPONSIBLE PERSON IN CHARGE OF WORK, TITLE		DATE	PHONE

THIS IS NOT A PERMIT/CONSTRUCTION MAY NOT COMMENCE UNTIL THE PERMIT IS ISSUED

SIGNAGE APPLICATION

THIS IS NOT A PERMIT
CONSTRUCTION CANNOT NOT COMMENCE UNTIL THE PERMIT IS ISSUED

In the interest of processing your application in the quickest possible manner, please complete the Information below for a Building or Use Permit.

If you or the property owner owes real estate or personal property taxes or user charges on any property within the City, payment arrangements must be made before permits of any kind are accepted.

Location/Address of Construction: <u>977 BRIGHTON AVE</u>		
Total Square Footage of Proposed Structure <u>30</u>	Square Footage of Lot	
Tax Assessor's Chart, Block & Lot Number Chart# <u>275</u> Block# <u>C</u> Lot# <u>001</u>	Owner: <u>WISE INVESTMENT PROPERTIES</u>	Telephone #: <u>772-1800</u>
Lessee/Buyer's Name (If Applicable) <u>INNOVATIVE NETWORK SOLUTIONS</u>	Owner's/Purchaser/Lessee Address: <u>977 BRIGHTON AVE PORTLAND, ME 04102</u>	Total s.f of signs <u>30</u> x <u>20</u> \$ <u>6.00</u> , plus \$30.00 100 <u>1.00</u> TOTAL \$ <u>36.00</u>
Current use: <u>OFFICE</u>	Proposed use: <u>OFFICE</u>	
Project description: <u>NEW SIGN</u>		
Applicants Name, Address & Telephone: <u>BURR SIGAUS 10 BUTTONWOOD ST. 30. PORTLAND, ME 04106</u>	<u>also</u> <u>has been paid</u>	
Contractor's Name, Address & Telephone: <u>SAME</u>	<u>hex</u>	
Who shall we contact when the permit is ready: Telephone:	↑	
If you would like it mailed, what mailing address should we use:	↑	
DEPT. OF BUILDING INSPECTION CITY OF PORTLAND, ME FEB 12 2009 Rec'd By:		

**THIS IS NOT A PERMIT/CONSTRUCTION MAY NOT COMMENCE UNTIL THE
PERMIT IS ISSUED**

If the property is located in a **HISTORIC DISTRICT**, a separate sketch is required indicating the design, dimensions, construction materials and source of illumination if any. A photograph of the building façade should be submitted, showing where each sign is to be installed.

Certification

I hereby certify that I am the Owner of record of the named property, or that the owner of record authorizes the proposed work and that I have been authorized by the owner to make this application as his/her authorized agent. I agree to conform to all applicable laws of this jurisdiction. In addition, if a permit for work described in this application is issued, I certify that the Code Official's authorized representative shall have the authority to enter all areas covered by this permit at any reasonable hour to enforce the provisions of the codes applicable to this permit.

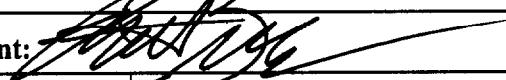
Signature of applicant: 	Date: 02/11/02
---	----------------

Sign Permit Fee: \$30.00 plus \$0.20 per square foot.

A building permit is also required for any awning based on cost of work-\$30.00 for the first \$1,000.00 and \$6.00 for each additional \$1,000.00

**BY FILLING OUT THIS APPLICATION IS DOES NOT MEET THAT
YOU WILL BE APPROVED FOR THE AMOUNT OF SIGNAGE YOU
ARE APPLYING FOR**

**IT IS SUGGESTED THAT YOU DO NOT ORDER ANY SIGNAGE UNTIL
YOU HAVE RECEIVED YOUR SIGN PERMIT THAT HAS BEEN
SIGNED BY THE BUILDING, ZONING AND POSSIBLE HISTORICAL
OFFICIALS OF THIS OFFICE**

Application ID Number: 2-0134

Department: Zoning

Status: Approved with Conditions

Reviewer: Marge Schmuckal

Comments: 977 Brighton Ave.

Approval Date: 02/19/2002

Blush On Date: 02/14/2002

OK to Issue Permit Name: Marge Schmuckal Date: 02/19/2002 Date 2:

Conditions Section:

The proposed sign shall be setback five (5) feet from the front property line.

You have proposed the street address building marker to appear in an area not encompassing your maximum square footage. ONLY THE STREET ADDRESS shall be placed within this area. If any other signage is extended into this area, it would be deemed an extension of your allowable signage. NO OTHER messages shall be present within this area. This information shall be passed on to the current owner and tenant.

Create Date: 02/13/2002 By: gg Update Date: 02/19/2002 By: mes

SIGNAGE PRE-APPLICATION

PLEASE ANSWER ALL QUESTIONS

ADDRESS: 977 BRIGHTON AVE ZONE: RP

OWNER: WISE INVESTMENT PROPERTIES

APPLICANT: BURR SIGNS

ASSESSOR NO. _____

PLEASE CIRCLE APPROPRIATE ANSWER

SINGLE TENANT LOT? YES NO

MULTI-TENANT LOT? YES NO

FREESTANDING SIGN? (ex. Pole Sign) YES NO --- DIMENSIONS 6'x5' HEIGHT 8'

MORE THAN ONE SIGN? YES NO DIMENSIONS _____ HEIGHT _____

SIGN ATTACHED TO BLDG.? YES NO DIMENSIONS _____

MORE THAN ONE SIGN? YES NO DIMENSIONS _____

AWNING: YES NO IS AWNING BACKLIT? YES NO HEIGHT OFF SIDEWALK _____

IS THERE ANY MESSAGE, TRADEMARK OR SYMBOL ON IT? _____

LIST ALL EXISTING SIGNAGE AND THEIR DIMENSIONS:

*** TENANT BLDG. FRONTAGE (IN FEET): _____

*** REQUIRED INFORMATION

only Free Standing Signs Permitted

AREA FOR COMPUTATION

Allowed 30' MAX - 30' show.

8' max height - 8' show.

5' set back from property line

YOU SHALL PROVIDE:

A SITE SKETCH AND BUILDING SKETCH SHOWING EXACTLY WHERE EXISTING AND NEW SIGNAGE IS LOCATED MUST BE PROVIDED. SKETCHES AND/OR PICTURES OF PROPOSED ARE ALSO REQUIRED.

SIGNATURE OF APPLICANT: [Signature]

DATE: 02/11/00

ACORD CERTIFICATE OF LIABILITY INSURANCE

DATE (MM/DD/YY)
02/08/02

PRODUCER HOLDEN AGENCY P O BOX 10610 PORTLAND MAINE 04104	THIS CERTIFICATE IS ISSUED AS A MATTER OF INFORMATION ONLY AND CONFERS NO RIGHTS UPON THE CERTIFICATE HOLDER. THIS CERTIFICATE DOES NOT AMEND, EXTEND OR ALTER THE COVERAGE AFFORDED BY THE POLICIES BELOW.
	COMPANIES AFFORDING COVERAGE COMPANY A ZURICH N.A. SMALL BUSINESS
INSURED WISE INVESTMENT PROPERTIES INC 977 BRIGHTON AVENUE PORTLAND, MAINE 04102	COMPANY B
	COMPANY C
	COMPANY D

COVERAGES
 THIS IS TO CERTIFY THAT THE POLICIES OF INSURANCE LISTED BELOW HAVE BEEN ISSUED TO THE INSURED NAMED ABOVE FOR THE POLICY PERIOD INDICATED, NOTWITHSTANDING ANY REQUIREMENT, TERM OR CONDITION OF ANY CONTRACT OR OTHER DOCUMENT WITH RESPECT TO WHICH THIS CERTIFICATE MAY BE ISSUED OR MAY PERTAIN, THE INSURANCE AFFORDED BY THE POLICIES DESCRIBED HEREIN IS SUBJECT TO ALL THE TERMS, EXCLUSIONS AND CONDITIONS OF SUCH POLICIES. LIMITS SHOWN MAY HAVE BEEN REDUCED BY PAID CLAIMS.

CO LTR	TYPE OF INSURANCE	POLICY NUMBER	POLICY EFFECTIVE DATE (MM/DD/YY)	POLICY EXPIRATION DATE (MM/DD/YY)	LIMITS
A	GENERAL LIABILITY <input checked="" type="checkbox"/> COMMERCIAL GENERAL LIABILITY <input type="checkbox"/> CLAIMS MADE <input checked="" type="checkbox"/> OCCUR <input type="checkbox"/> OWNER'S & CONTRACTOR'S PROT	PPS34073123	9/30/01	9/30/02	GENERAL AGGREGATE \$2,000,000
	PRODUCTS - COMP/OP AGG				\$2,000,000
	PERSONAL & ADV INJURY				\$1,000,000
	EACH OCCURRENCE				\$1,000,000
	FIRE DAMAGE (Any one fire)				\$1,000,000
	MED EXP (Any one person)				\$ 10,000
	AUTOMOBILE LIABILITY <input type="checkbox"/> ANY AUTO <input type="checkbox"/> ALL OWNED AUTOS <input type="checkbox"/> SCHEDULED AUTOS <input type="checkbox"/> HIRED AUTOS <input type="checkbox"/> NON-OWNED AUTOS				
GARAGE LIABILITY <input type="checkbox"/> ANY AUTO					AUTO ONLY - EA ACCIDENT \$ OTHER THAN AUTO ONLY: EACH ACCIDENT \$ AGGREGATE \$
A	EXCESS LIABILITY <input checked="" type="checkbox"/> UMBRELLA FORM <input type="checkbox"/> OTHER THAN UMBRELLA FORM	PPS34073123	9/30/01	9/30/02	EACH OCCURRENCE \$2,000,000
	AGGREGATE				\$2,000,000
	WC STATUTORY LIMITS				\$
	OTH-ER				\$
WORKERS COMPENSATION AND EMPLOYERS' LIABILITY THE PROPRIETOR/PARTNERS/EXECUTIVE OFFICERS ARE: <input type="checkbox"/> INCL <input type="checkbox"/> EXCL					EL EACH ACCIDENT \$ EL DISEASE-POLICY LIMIT \$ EL DISEASE-EA EMPLOYEE \$
OTHER					

DESCRIPTION OF OPERATIONS/LOCATIONS/VEHICLES/SPECIAL ITEMS
 REF: INSTALLATION OF AN OUTDOOR SIGN AT 977 BRIGHTON AVENUE, PORTLAND, MAINE
 THE CERTIFICATE HOLDER IS ADDED AS AN ADDITIONAL INSURED FOR LIABILITY

CERTIFICATE HOLDER CITY OF PORTLAND, MAINE 389 CONGRESS STREET PORTLAND, MAINE 04101	CANCELLATION SHOULD ANY OF THE ABOVE DESCRIBED POLICIES BE CANCELLED BEFORE THE EXPIRATION DATE THEREOF, THE ISSUING COMPANY WILL ENDEAVOR TO MAIL 30 DAYS WRITTEN NOTICE TO THE CERTIFICATE HOLDER NAMED TO THE LEFT, BUT FAILURE TO MAIL SUCH NOTICE SHALL IMPOSE NO OBLIGATION OR LIABILITY OF ANY KIND UPON THE COMPANY, ITS AGENTS OR REPRESENTATIVES.
	AUTHORIZED REPRESENTATIVE <i>Eric Wright</i> Eric Wright EW A



10 Buttonwood St.
South Portland, ME 04106

Recipient: Tammy Munson

Sent By: Randy Burr

Company: City of Portland

Company: Burr Signs

Fax Number: 8748716

Fax Number: 2077991324

Voice Number:

Voice Number: 2077991183

Date: 2/21/02

Time: 9:29:49 AM

Total No. Pages: 2

Subject: 977 Brighton Ave. sign

Message:

Construction & installation detail per your request.

FRONT ELEVATION

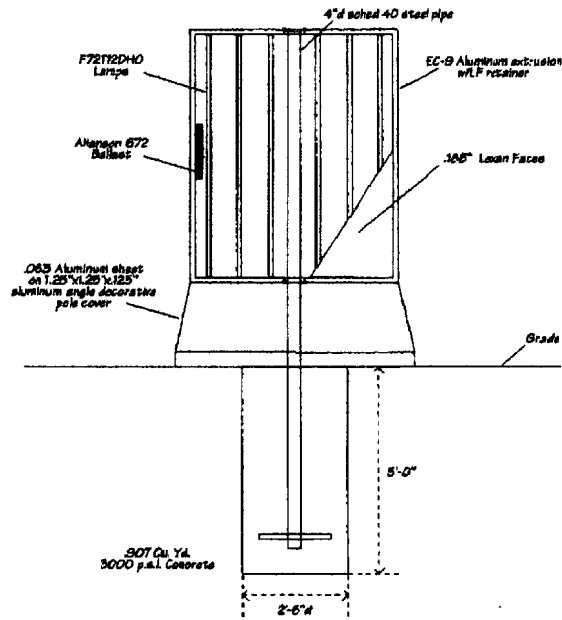

SIDE ELEVATION

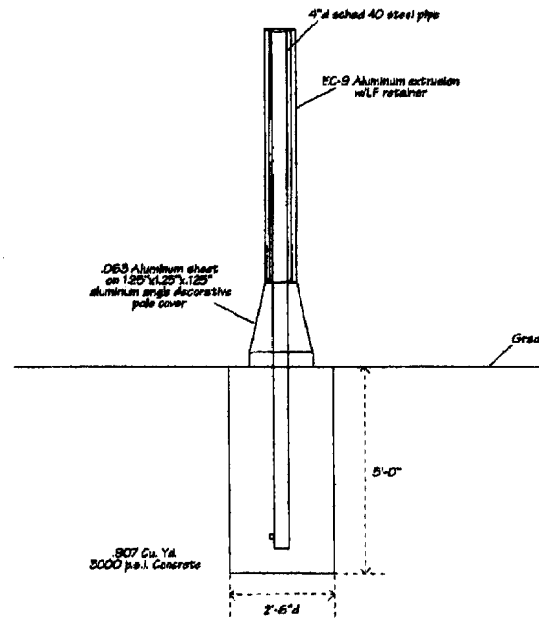

10 BURNHAMWOOD S.
20, SCOTLAND ME 04106
PH: 207-794-1180 FAX: 207-799-1824

THIS DESIGN IS THE EXCLUSIVE PROPERTY OF BURR SIGNS. ALL PRODUCTION AND REPRODUCTION RIGHTS ARE RESERVED BY US.
THIS PRINT HAS BEEN DESIGNED FOR YOUR BUSINESS AND IS NOT TO BE REPRODUCED, COPIED, USED, OR EXHIBITED OUTSIDE OF YOUR COMPANY OR ORGANIZATION WITHOUT THE EXPRESSED WRITTEN PERMISSION OF BURR SIGNS. © Copyright

CLIENT	INS
LOCATION	977 BRIGHTON AVE. PORTLAND, ME
SALES PERSON	R. BURR
DRAWN BY	R. BURR
SCALE	1" = 40'
DATE	02/05/02
ACCEPTANCE SIGNATURE	
DESIGNING NO	INS 1b.cd
COLORS SHOWN HERE MAY NOT REPRESENT ACTUAL COLORS. COLOR MATCH NUMBERS MAY BE REQUIRED.	



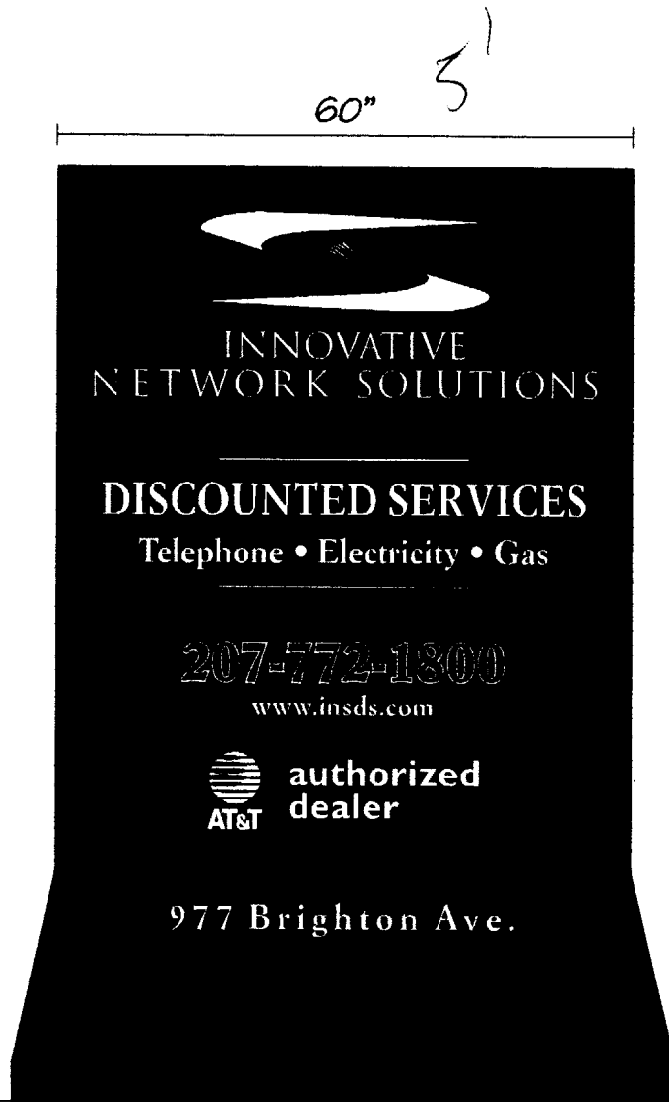

60" 5'

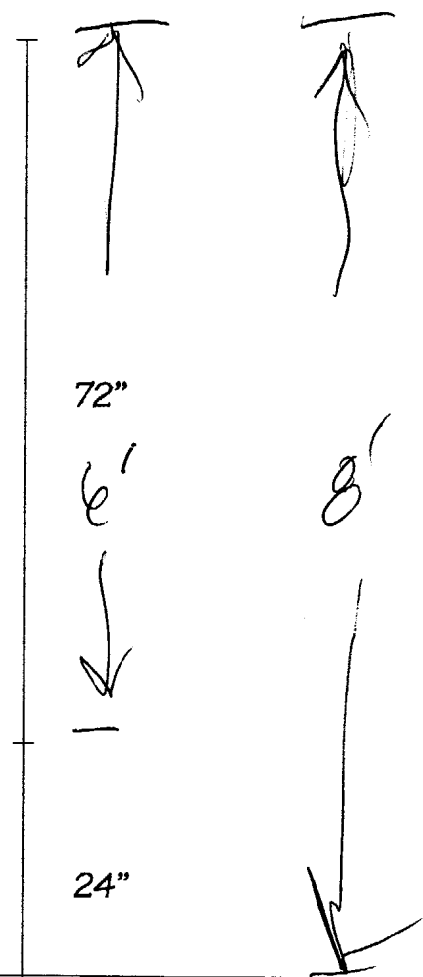

H.O.A. - 96"

Sign Elevation - 6'x5'x9" D/F Internally illuminated monument sign



Existing

16' BACKLOG
TO SIDEWALK

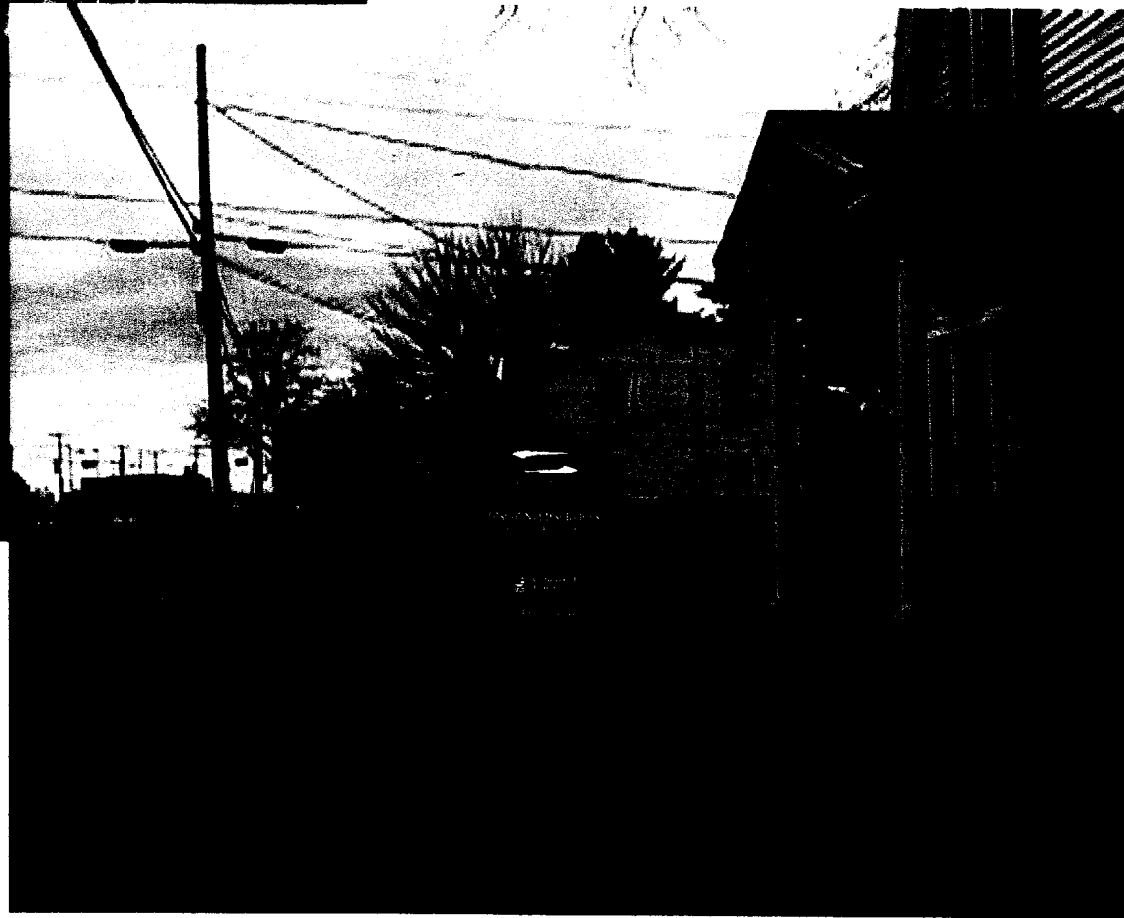

Proposed

BUILDING PERMIT INSPECTION PROCEDURES

Please call 874-8703 or 874-8693 to schedule your inspections as agreed upon

Permits expire in 6 months, if the project is not started or ceases for 6 months.

The Owner or their designee is required to notify the inspections office for the following inspections and provide adequate notice. Notice must be called in 48-72 hours in advance in order to schedule an inspection:

By initializing at each inspection time, you are agreeing that you understand the inspection procedure and additional fees from a "Stop Work Order" and "Stop Work Order Release" will be incurred if the procedure is not followed as stated below.

N/A Pre-construction Meeting: Must be scheduled with your inspection team upon receipt of this permit. Jay Reynolds, Development Review Coordinator at 874-8632 must also be contacted at this time, before any site work begins on any project other than single family additions or alterations.

N/A Footing/Building Location Inspection: Prior to pouring concrete

N/A Re-Bar Schedule Inspection: Prior to pouring concrete

N/A Foundation Inspection: Prior to placing ANY backfill

N/A Framing/Rough Plumbing/Electrical: Prior to any insulating or drywalling

PS Final/Certificate of Occupancy: Prior to any occupancy of the structure or use. NOTE: There is a \$75.00 fee per inspection at this point.

Certificate of Occupancy is not required for certain projects. Your inspector can advise you if your project requires a Certificate of Occupancy. All projects DO require a final inspection.

N/A If any of the inspections do not occur, the project cannot go on to the next phase, REGARDLESS OF THE NOTICE OR CIRCUMSTANCES.

N/A CERTIFICATE OF OCCUPANICES MUST BE ISSUED AND PAID FOR, BEFORE THE SPACE MAY BE OCCUPIED

Signature of applicant/designee

Date

[Signature]
Signature of Inspections Official

2/27/02
Date

CBL: 275 C001 Building Permit #: 020134

Will call when sign is in place