

CBL. 274-0016001

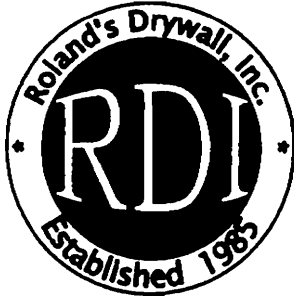

Roland's Drywall, Inc.

62 Greene St. Sabattus, Me. 04280

Telephone: (207) 375-4410 or (207) 375-8723

Fax: (207) 375-4698 E-Mail: info@rolandsdrywall.com

SUBMITTALS

DATE: August 13, 2007

PROJECT: University Credit Union, Brighton Ave., Portland, Maine

ARCHITECT: Shremshock Architects, Inc., Westerville, Oh

GENERAL CONTRACTOR: Buildpartners, Rochester, NH.

SUBCONTRACTOR: Roland's Drywall, Inc., Sabattus, Me.

SUPPLIER (S)

SECTION: EIFS

<u>Item</u>	<u>Mfgr</u>	<u>PAGE</u>
STO Guard Description	STO	2
STO Essence Next Description	STO	3
Specifications	STO	4
Details	STO	5

sto[®]

**Sto Exterior
Insulation
and Finish
Systems**

Advanced
Performance and
Design Versatility

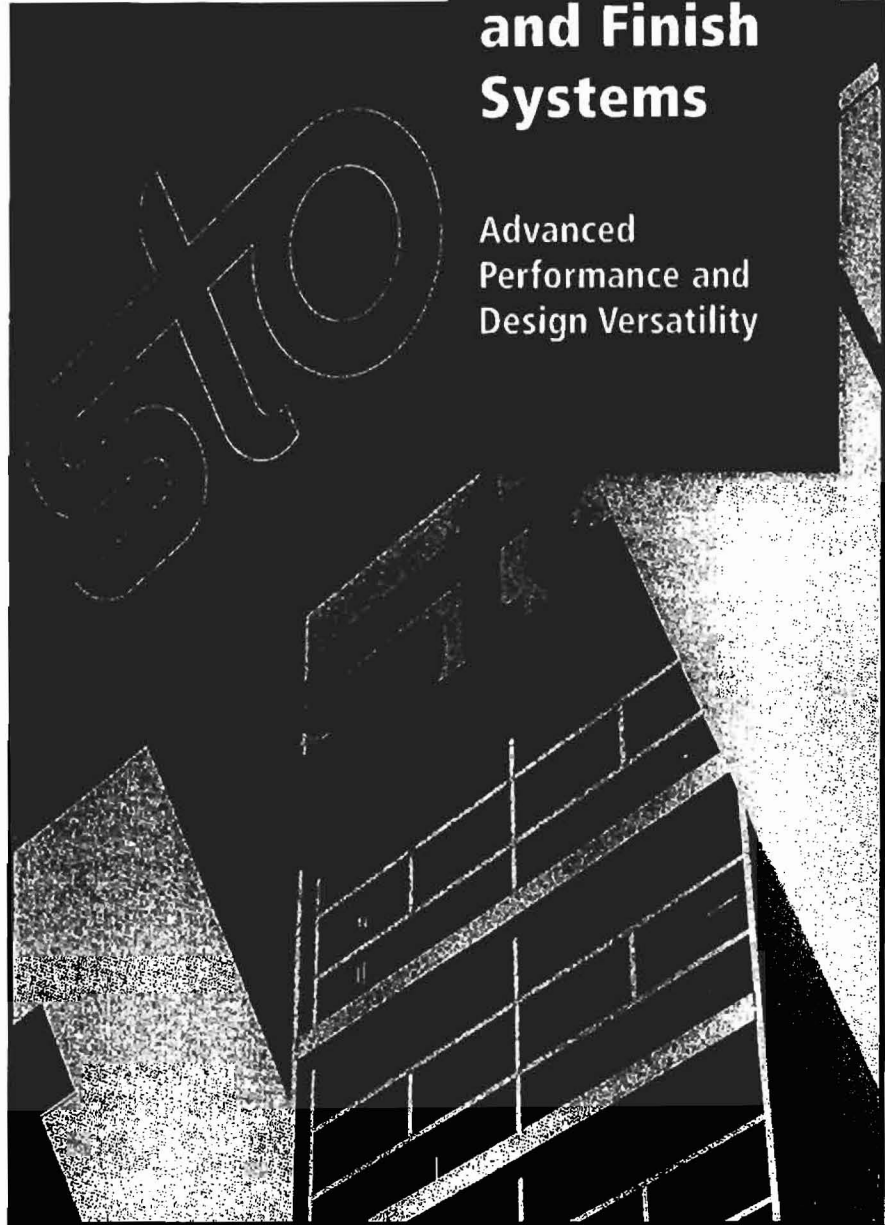

Sto Has A System Right For Every Project

Since Sto introduced its EIF Systems in Europe in 1963 and brought the first 100% acrylic System to the United States in 1979, Sto has led the market in quality, performance and innovative systems solutions.

At Sto, we believe in a systems approach to building. We offer three high-performance Wall Systems based on price and performance features to meet your project requirements.

For 2002, Sto introduces the latest innovation in EIFS, Sto **EIFS NExT™** with all the benefits of a Sto EIF system plus the best water/air barrier system for extra protection.

- All Sto products are designed to work compatibly together to form superior Wall Systems
- All Sto products are manufactured to exacting standards from highest quality raw materials
- All Sto factories are ISO 9001 quality system certified
- All Sto products are VOC compliant, safe for workers and environmentally friendly
- Hundreds of millions of square feet of Sto Systems are in place and performing beautifully across North America
- All Sto EIFS meet model building codes, including: BOCA - ICBO - SBCCI - CCMC (Canada)
- Sto is an active member of EIMA, the EIFS Industry Members Association
- All Sto EIFS meet or exceed EIMA guideline specifications and test standards

From the rain forests of the Pacific Northwest to the Southwestern deserts, from the snowy elevations of the Rockies to the humid Atlantic coast, Sto Systems have proven themselves superior in performance, design flexibility, durability, and value.

Sto Guard™

Superior Moisture Protection for your Building Investment

Sto Guard is a continuous, liquid-applied waterproof membrane that bonds directly to sheathing and other construction elements to resist air and water penetration. It creates an unbroken seamless barrier for superior moisture protection for homes and commercial buildings.

Unlike typical building paper or house wraps that are easily damaged or torn during the construction process, Sto Guard is adhesively attached, seamless, tough and durable. It protects so well that surfaces protected with Sto Guard can be left uncovered for up to six months, protecting sheathing during and after construction, before the cladding is installed.

Sto Guard can be used with a variety of sheathings including gypsum sheathing, Dens Glass® Gold*, plywood, OSB and cement board sheathing. It can be used to protect buildings clad with EIFS, brick or siding products. Sto Guard consists of two component products:

Sto Gold Fill®

- Flexible; provides continuous protection for rough openings and sheathing joints by bridging gaps created by normal movement
- Water-based; easy to clean-up; environmentally friendly
- Trowel-applied; standard trowel application techniques

Sto Gold Coat®

- Waterproof; creates a protective barrier for sheathing against moisture intrusion
- Roller-applied; fast, easy application; reduced labor costs
- Gold color; helps ensure even coverage
- Resists air infiltration; reduces energy costs while increasing interior comfort
- Water-based; easy to clean up; environmentally friendly

*Dens Glass® Gold is a registered trademark of G-P Gypsum Corp.

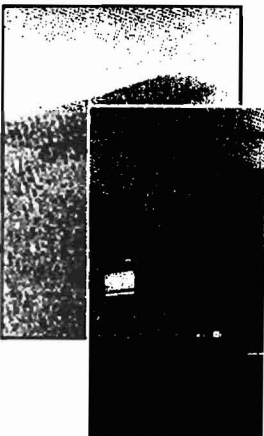

Sto EIFS NExT™ Goes Beyond EIFS

Sto EIFS NExT (New Exterior Technology) goes far beyond conventional EIFS, combining the very best technologically advanced system of liquid-applied moisture protection with the proven performance features of Sto's Wall Systems to create the next evolution of EIFS.

Sto EIFS NExT incorporates the Sto Guard™ system to create a continuous secondary air and moisture barrier behind Sto EIFS to protect the sheathing and other construction components. Sto Guard resists water penetration more than 5 times longer than leading brand house wraps, and more than 28 times longer than conventional building paper.

Sto EIFS NExT is created by combining Sto Guard with starter track and vertical ribbons of adhesive. Sto EIFS NExT provides all the benefits of EIFS including adhesive attachment in a system designed to meet stringent building codes for moisture protection of all types of commercial and residential construction, including wood frame construction.

All Sto Systems feature finishes using 100% Acrylic polymers for flexibility and crack resistance, integral color and matte finish for color uniformity and lasting beauty, 100% pure white marble aggregates for bright colors and absolutely no rust, and are water-based to be environmentally friendly.

Sto Classic NExT™

- Meets or exceeds all industry performance requirements
- Excellent vapor permeability; resists blistering, peeling, bubbling
- Excellent weatherability; resists wind-driven rain and ultraviolet light
- Self-gauging cementitious base coat helps assure proper base coat thickness
- Cementitious base coat features low cement content for reduced risk of efflorescence
- 100% acrylic base coat is available; eliminates efflorescence risk
- Greater resistance to algae, mildew and mold growth
- Choice of a wide variety of textures
- Lower maintenance

*Sto Classic NExT comes with an 11-year Limited Labor and Material Warranty.
Sto Classic (without Sto Guard) is available with a 6-year Limited Labor and Material Warranty for use where secondary moisture protection is not required.*

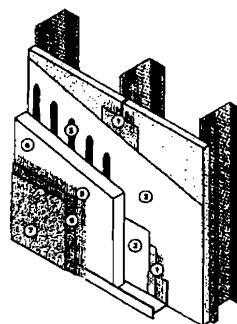

1. Sto Gold Fill® and Mesh
2. Sto Gold Coat®
3. Sto BTS™ Plus Adhesive
4. Sto EPS Insulation
5. Sto Mesh
6. Sto BTS™ Plus Base Coat
7. Stolit® Finish

Sto Essence NExT™

- Meets all industry performance requirements
- Vapor permeable; resists blistering, peeling, bubbling
- Good weatherability; resists wind-driven rain and ultraviolet light
- Cementitious base coat is factory blended for quality control
- Provides resistance to algae and mildew growth
- Choice of 3 textures

*Sto Essence NExT comes with a 10-year Limited Labor and Material Warranty.
Sto Essence (without Sto Guard) is available with a 5-year Limited Labor and Material Warranty for use where secondary moisture protection is not required.*

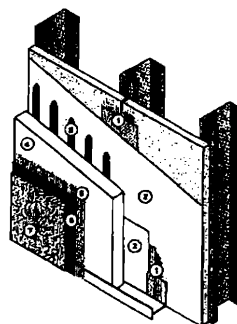

1. Sto Gold Fill and Mesh
2. Sto Gold Coat
3. Sto Primer/Adhesive-B Adhesive
4. Sto EPS Insulation
5. Sto Mesh
6. Sto Primer/Adhesive-B Base Coat
7. Sto Essence Finish

Sto Premier NExT™

- Meets or exceeds all industry performance requirements
- Superior vapor permeability; resists blistering, peeling, bubbling
- Increased resistance to water absorption
- Superior weather resistance; resists wind-driven rain
- Superior fade resistance, best color retention
- Superior resistance to algae, mildew and mold growth
- Superior UV resistance and color retention
- Lowest maintenance

*Sto Premier NExT comes with a 12-year Limited Labor and Material Warranty.
Sto Premier (without Sto Guard) is available with a 7-year Limited Labor and Material Warranty for use where secondary moisture protection is not required.*

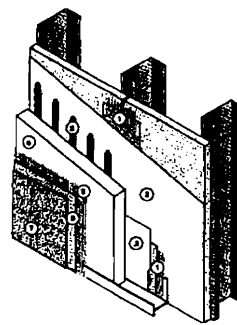

1. Sto Gold Fill and Mesh
2. Sto Gold Coat
3. Sto BTS Plus Adhesive
4. Sto EPS Insulation
5. Sto Mesh
6. Sto BTS Plus Base Coat
7. StoSilco® Lit Finish

Sto Class PB Exterior Insulation and Finish Systems (EIFS)
Sto Short Form Specification A2000
Section 07240

Part 1 GENERAL

1.01 SECTION INCLUDES

- A. Materials and installation of air and moisture barrier and Class PB EIFS.

1.02 DELIVERY, STORAGE AND HANDLING

- A. Deliver all materials in their original sealed container bearing manufacturer's name and identification of product.
- B. Protect coatings (pail products) from freezing and temperatures in excess of 90°F (32°C). Store away from direct sunlight.
- C. Protect Portland cement based materials (bag products) from moisture and humidity. Store under cover off the ground in a dry location.

1.03 COORDINATION/SCHEDULING

(The work in this section requires close coordination with related sections and trades. Sequence work to provide protection of construction materials from weather deterioration).

- A. Protect rough openings with air and moisture barrier at sills before installing doors, windows and other penetrations through the wall.
- B. Install window and door head flashing immediately after windows and doors are installed.
- C. Install diverter flashing wherever water can enter the assembly to direct water to the exterior.
- D. Install copings immediately after installation of the EIF system and when EIFS coatings are dry or provide temporary waterproofing until coping is installed.
- E. Install sealant immediately after installation of the EIF system and when EIFS coatings are dry or provide temporary waterproofing until sealant is installed.

Part 2 PRODUCTS

2.01 MANUFACTURERS

- A. Sto Corp. (Air and Moisture Barrier and EIFS Components)
- B. Plastic Components, Inc. (Starter Track)
- C. Provide EIFS and air and moisture barrier components from single source manufacturer or approved supplier

2.02 AIR AND MOISTURE BARRIER

(Recommended for all applications over sheathing, and as a part of Sto EIFS NExT™).

- A. Sto Guard™—air and moisture barrier for sheathing consisting of:
 - 1. Sto Gold Fill®—trowel-applied joint compound for rough opening protection, sheathing joints and inside and outside corners
 - 2. Sto Detail Mesh—reinforcing mesh for use with Sto Gold Fill
 - 3. Sto Gold Coar®—roller-applied waterproof coating for wall sheathing

2.03 CLASS PB EIFS

System Component	Sto Classic System	Sto Essence System	Sto Premier System
Adhesive	Sto BTS™ Plus or Sto Dispersion Adhesive	Sto Primer/Adhesive-B or Sto Primer/Adhesive or Sto Dispersion Adhesive	Sto BTS™ Plus or Sto Dispersion Adhesive
Insulation	Sto EPS Insulation Board	Sto EPS Insulation Board	Sto EPS Insulation Board
Base Coat	Sto BTS Plus or Sto RFP	Sto Primer/Adhesive-B or Sto Primer/Adhesive	Sto BTS Plus or Sto RFP
Reinforcing Mesh	Sto Mesh	Sto Mesh	Sto Mesh
Finish	Stolit®	Sto Essence Finish	StoSilco® Lit

Note: Sto Primer is an optional component recommended prior to application of finish coat for best color uniformity and for small (< 1.0 mm) aggregate finishes. Additional mesh reinforcement with Sto Armor Mat is recommended for areas subject to abuse or impact, generally at ground floors to a minimum height of 6'-0" (1.8 m).

2.04 JOB MIXED INGREDIENTS

- A. Portland Cement: ASTM C 150, Type 1.
- B. Water: Clean and potable.

2.05 ACCESSORIES

- A. Starter Track—rigid PVC (polyvinyl chloride) plastic track with weepholes and drip edge as furnished by Plastic Components, Inc. (Part No. STDE).

2.06 MIXING

- A. Mix materials in accordance with manufacturer's published instructions.

Part 3 EXECUTION

3.01 INSTALLATION

- A. Install air and moisture barrier and Class PB EIFS in accordance with manufacturer's published instructions.

3.02 PROTECTION

- A. Provide protection of installed materials from water infiltration into or behind them.
- B. Provide protection of installed materials from dust, dirt, precipitation, freezing and continuous high humidity until materials are fully dry.

sto

Sto NExT

Insulated Wall Claddings

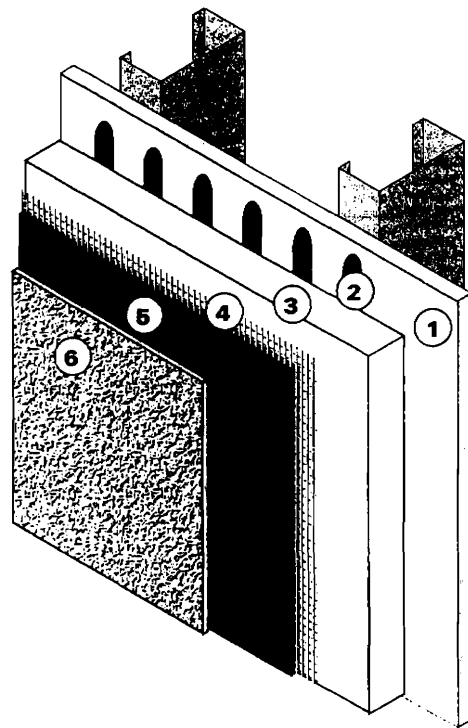

Specification and Details

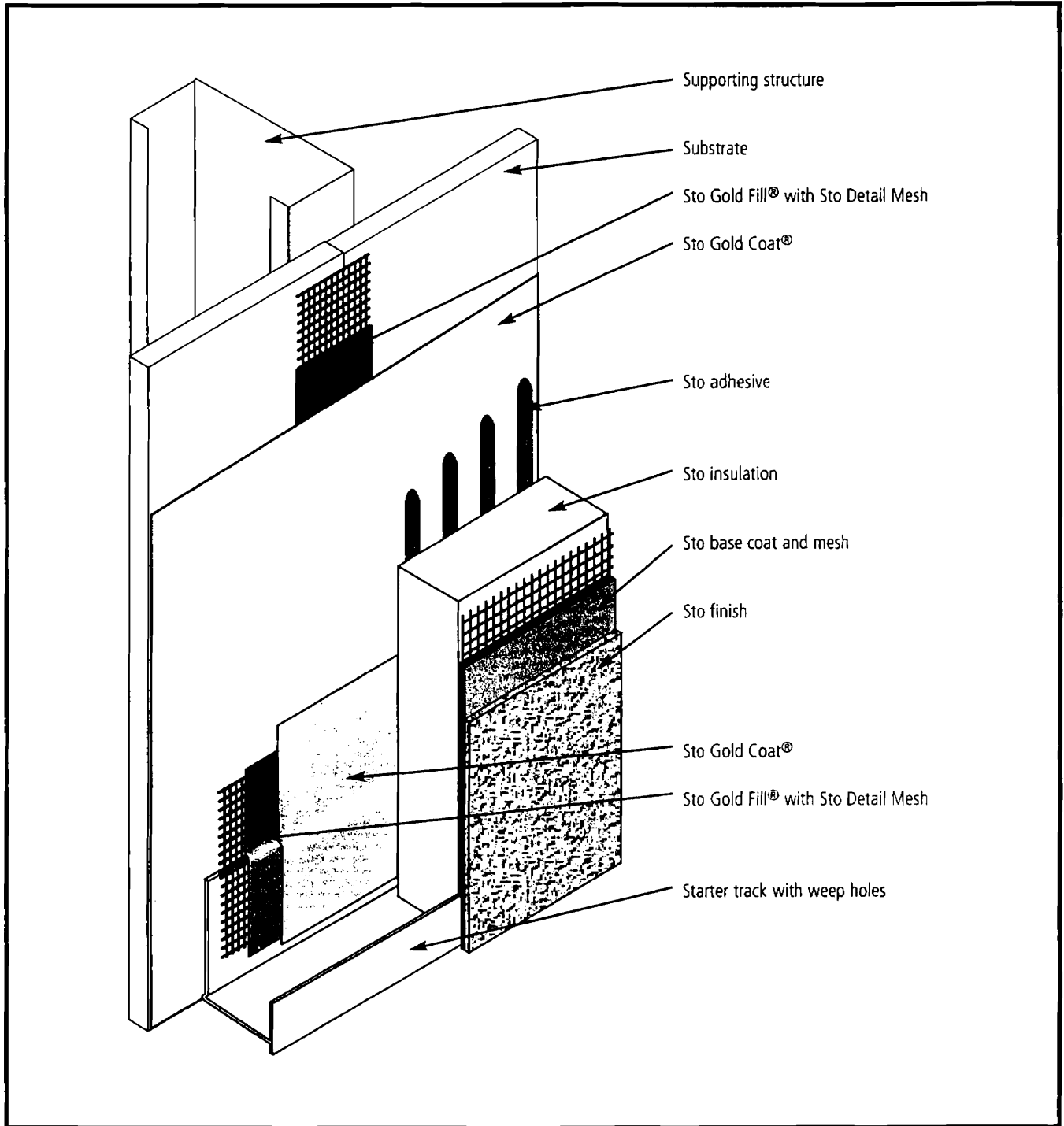

Notes:

Detail shows the components of a Sto Exterior Insulation and Finish System (EIFS) with Sto Guard™ Moisture Protection.

Sto Guard™:

- 1) Sto Gold Fill® with Sto Detail Mesh
- 2) Sto Gold Coat®

Sto EIFS:

- 1) Sto adhesive
- 2) Sto insulation
- 3) Sto base coat
- 4) Sto mesh
- 5) Sto finish

Sto Gold Coat® and Sto Gold Fill® are registered trademarks of Sto Corp.

Sto details are illustrations of construction. They are guidelines, intended for use by the design/construction professional, to assist in developing project specific details. They should be modified where necessary to accommodate individual project conditions. Refer to appropriate Sto specification for design requirements. Refer to local building code for any special requirements.



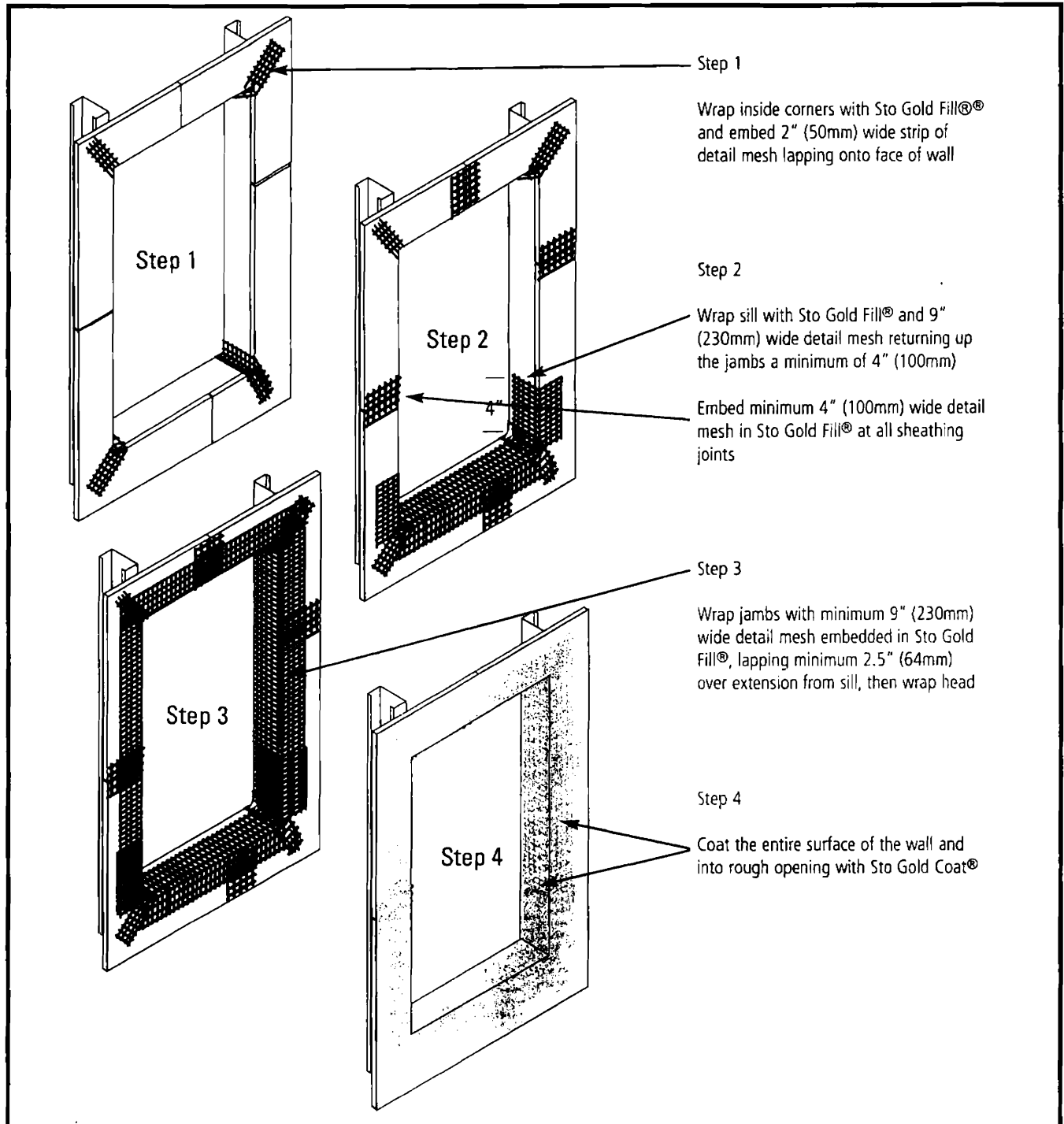

Notes:

- 1] Prepare opening prior to the installation of the window or mechanical equipment. Create a slope to the exterior at the sill with a sill wedge.
- 2] Incorporate flashing as illustrated in 10.23b and 10.23c or as per other details where flashing is shown (e.g. 10.25).
- 3] The complete installation of window or mechanical equipment should include an air seal between the object and the Sto Guard™ protection inbound of the outer sealant joint.

Sto Gold Coat® and Sto Gold Fill® are registered trademarks of Sto Corp.

Sto details are illustrations of construction. They are guidelines, intended for use by the design/construction professional, to assist in developing project specific details. They should be modified where necessary to accommodate individual project conditions. Refer to appropriate Sto specification for design requirements. Refer to local building code for any special requirements.

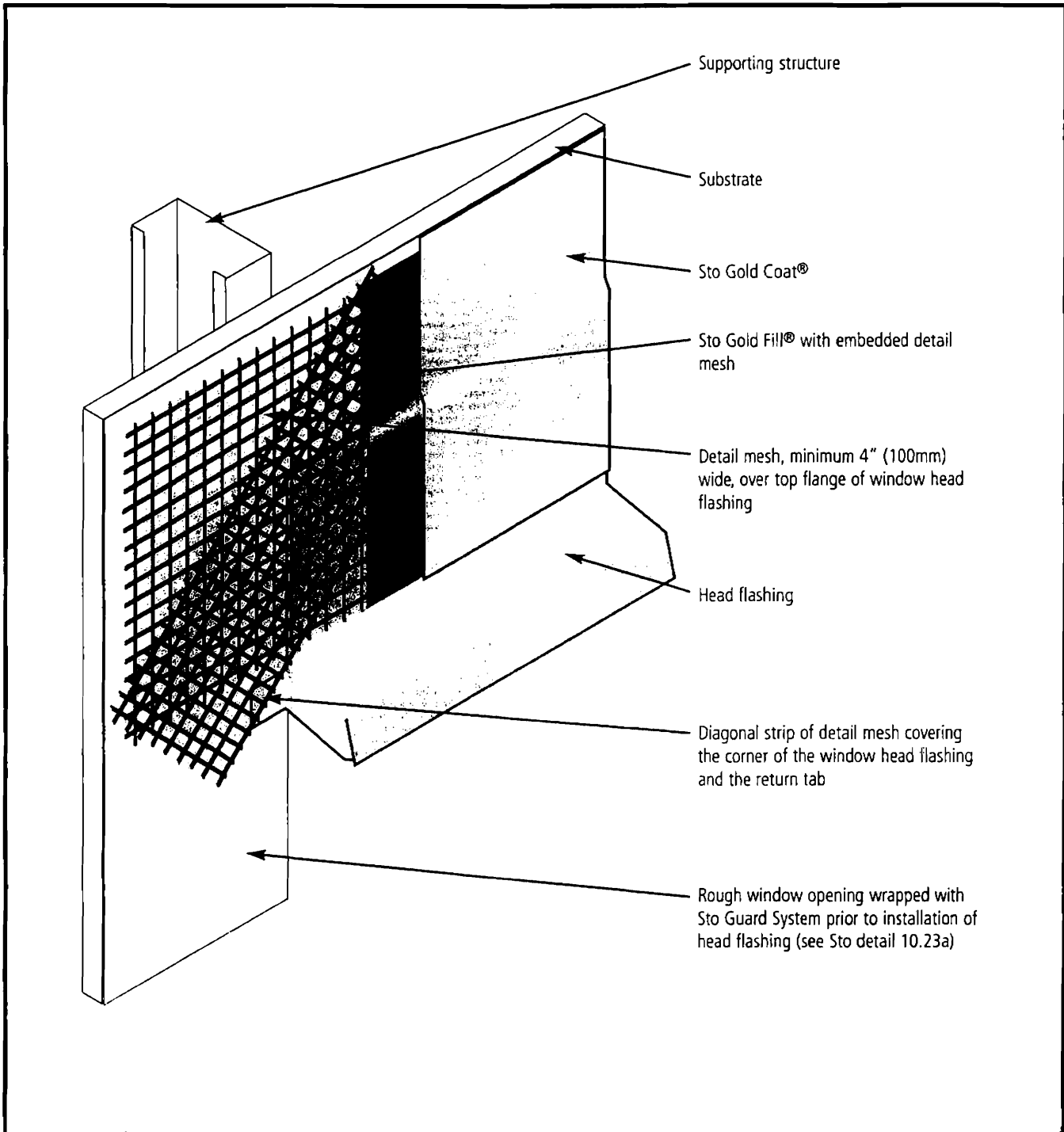

Notes:

- 1] Provide head flashing as required by local building codes and window manufacturer.
- 2] Coordinate Sto Guard™ installation sequence with window installer and other related trades.

Sto Gold Coat® and Sto Gold Fill® are registered trademarks of Sto Corp.

Sto details are illustrations of construction. They are guidelines, intended for use by the design/construction professional, to assist in developing project specific details. They should be modified where necessary to accommodate individual project conditions. Refer to appropriate Sto specification for design requirements. Refer to local building code for any special requirements.



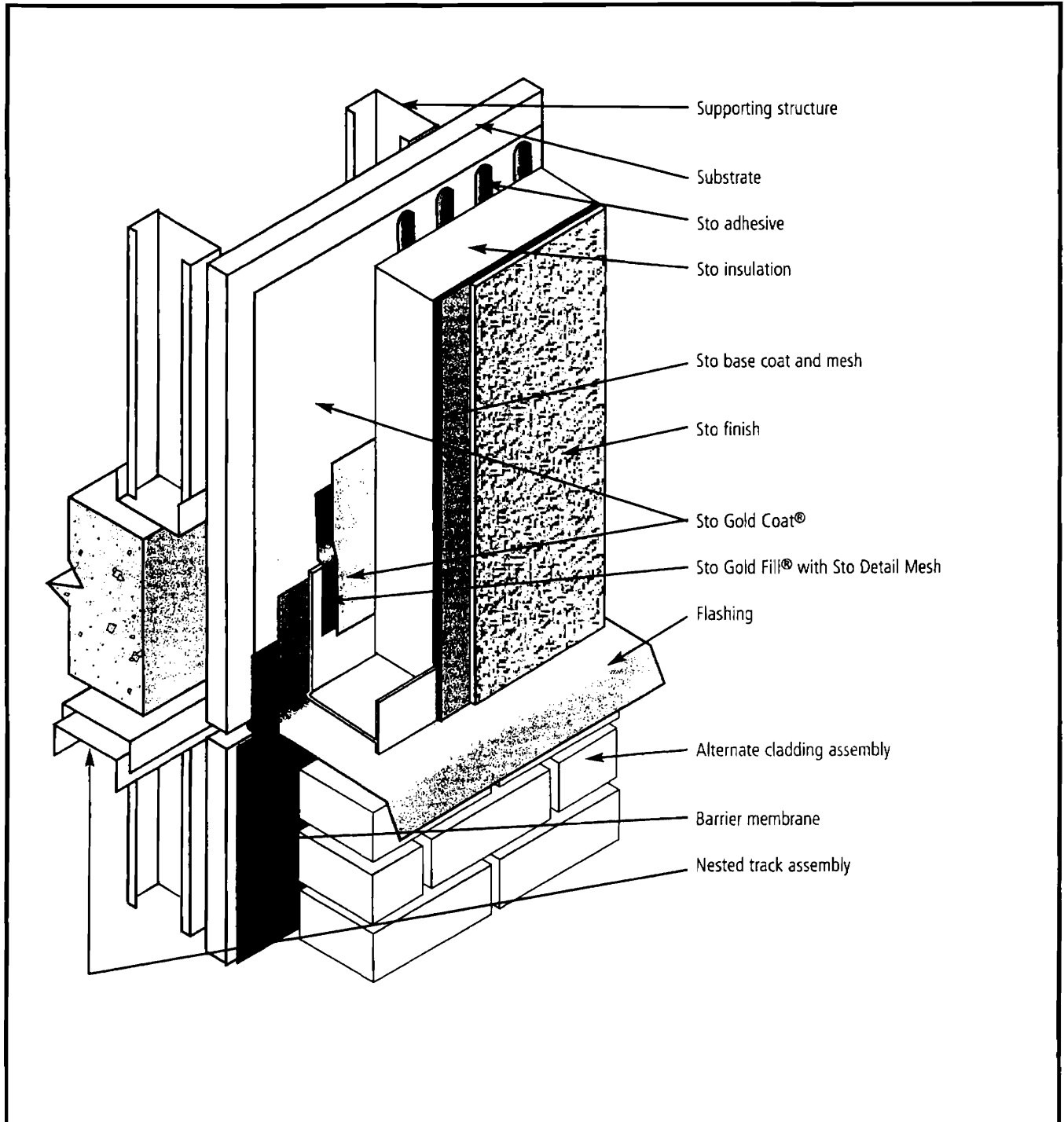

Notes:

- 1) Do not attach upper sheathing to nested track. Only attach lower sheathing to nested track.
- 2) The maximum allowable sheathing span at the floor line is 8" (200 mm) or as recommended by the sheathing manufacturer.
- 3) Provide flashing minimum 4" (100 mm) behind the Sto EIFS and project beyond the face of the alternate cladding below.
- 4) Consider the amount of movement in the alternate cladding material, especially if a different structural support system exists for that cladding. Position flashing to accommodate movement and ensure drainage to the exterior.
- 5) Determine installation sequence in advance of construction.

Sto Gold Coat® and Sto Gold Fill® are registered trademarks of Sto Corp.

Sto details are illustrations of construction. They are guidelines, intended for use by the design/construction professional, to assist in developing project specific details. They should be modified where necessary to accommodate individual project conditions. Refer to appropriate Sto specification for design requirements. Refer to local building code for any special requirements.

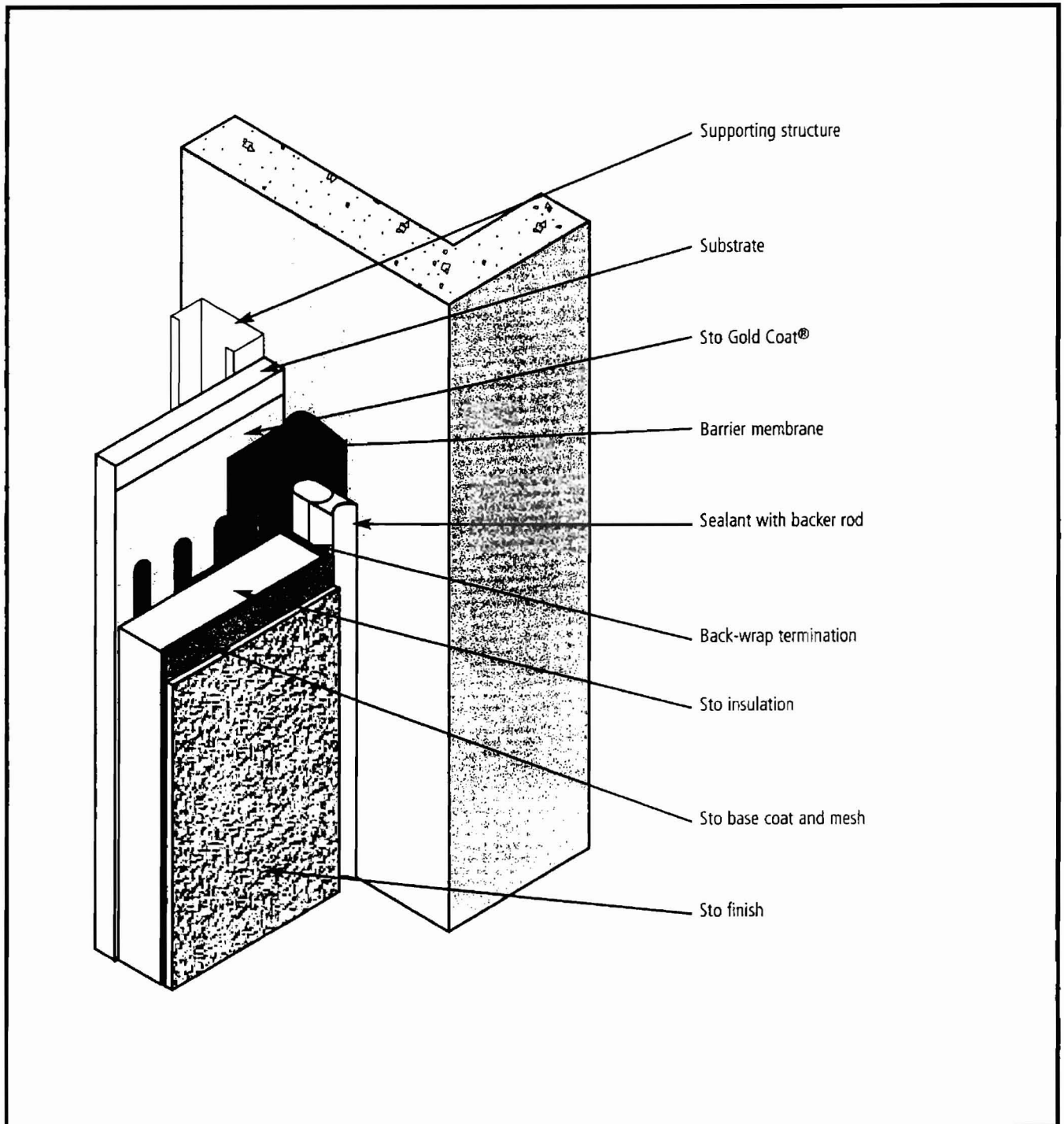

Notes:

- 1| Provide a barrier membrane between the substrate and dissimilar material to provide an air barrier and a secondary weather barrier at the joint.
- 2| Provide minimum 3/4" (20 mm) joint width.
- 3| Provide drainage for joint assembly

Sto Gold Coat® and Sto Gold Fill® are registered trademarks of Sto Corp.

Sto details are illustrations of construction. They are guidelines, intended for use by the design/construction professional, to assist in developing project specific details. They should be modified where necessary to accommodate individual project conditions. Refer to appropriate Sto specification for design requirements. Refer to local building code for any special requirements.

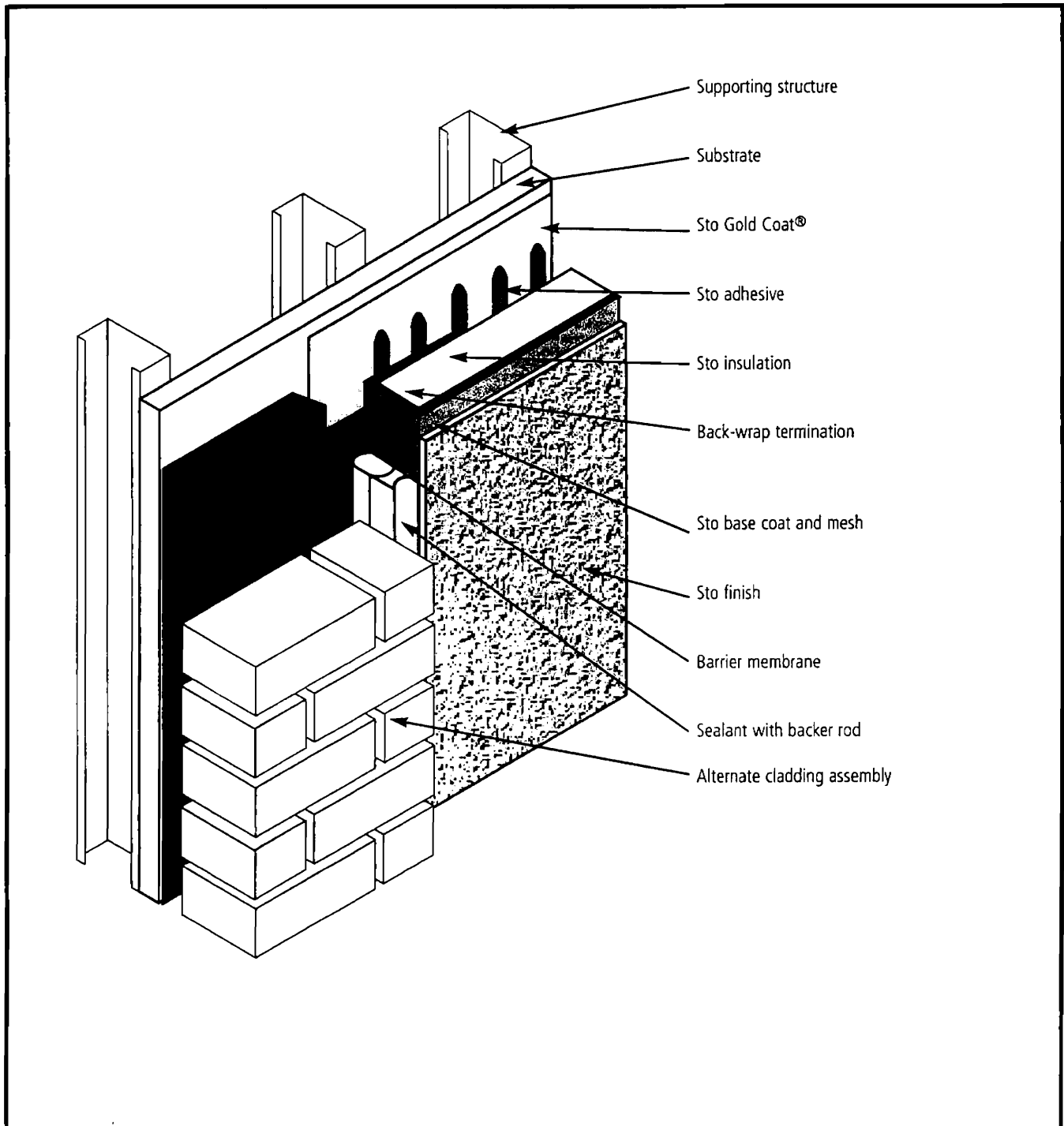

Notes:

- 1] Determine installation sequence in advance of construction. Coordinate subtrades to ensure the proper installation of materials.
- 2] Barrier membrane isolates the potentially wet environment behind the alternate cladding from the EIFS.
- 3] Provide minimum 3/4" (20 mm) joint between the EIFS and the alternate cladding. Provide drainage for the joint assembly.

Sto Gold Coat® and Sto Gold Fill® are registered trademarks of Sto Corp.

Sto details are illustrations of construction. They are guidelines, intended for use by the design/construction professional, to assist in developing project specific details. They should be modified where necessary to accommodate individual project conditions. Refer to appropriate Sto specification for design requirements. Refer to local building code for any special requirements.

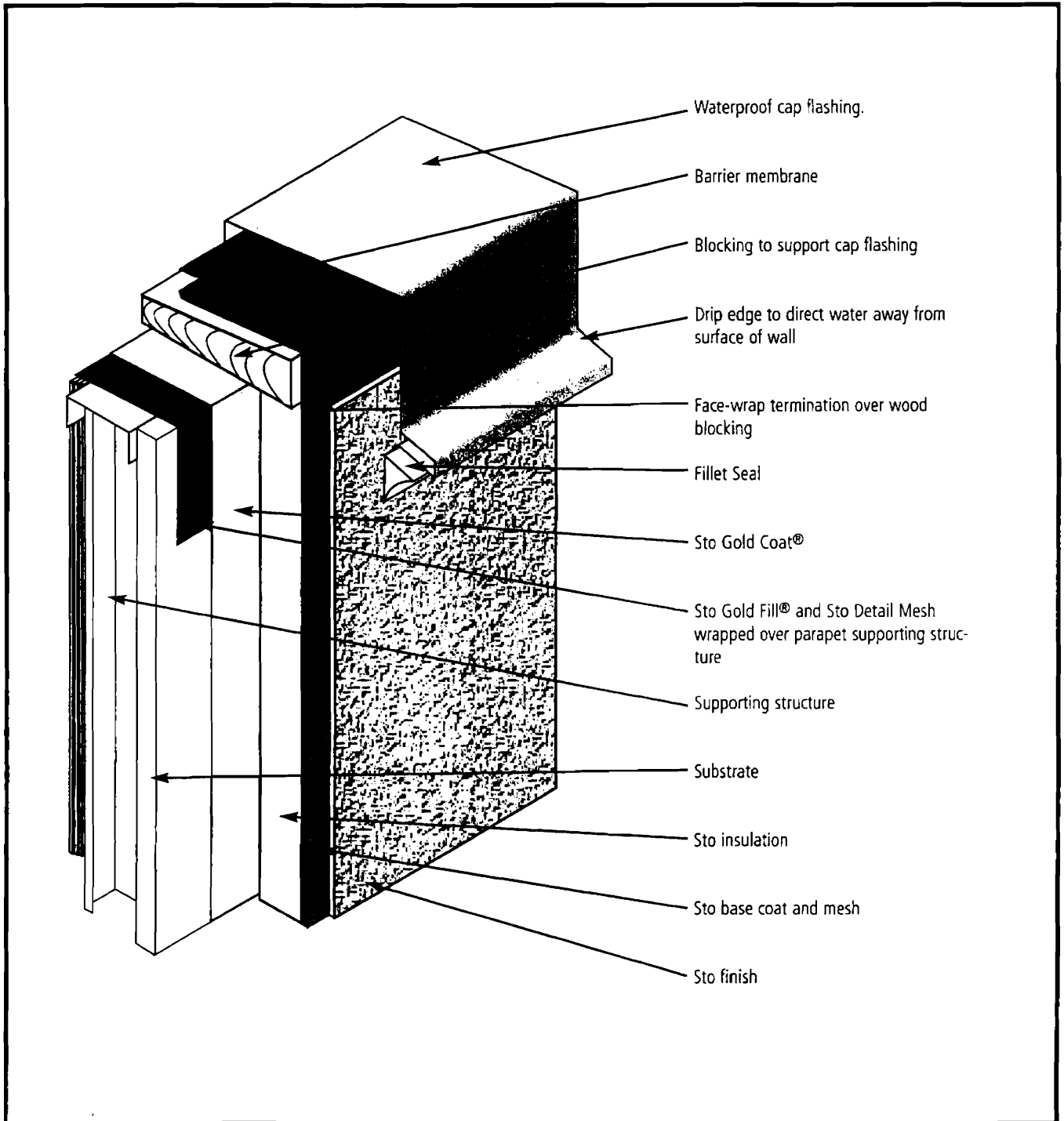

Notes:

- 1] Provide a barrier membrane over the parapet and integrate it with the roofing or deck waterproofing assembly. This provides air barrier continuity over the parapet and secondary weather protection under the cap flashing.
- 2] Provide minimum 2.5" (65 mm) overlap of flashing over face of EIFS. Increase overlap with building height.
- 3] Install Sto Guard™ System over the parapet supporting structure lapping onto compatible sheathing.

Sto Gold Coat® and Sto Gold Fill® are registered trademarks of Sto Corp.

Sto details are illustrations of construction. They are guidelines, intended for use by the design/construction professional, to assist in developing project specific details. They should be modified where necessary to accommodate individual project conditions. Refer to appropriate Sto specification for design requirements. Refer to local building code for any special requirements.

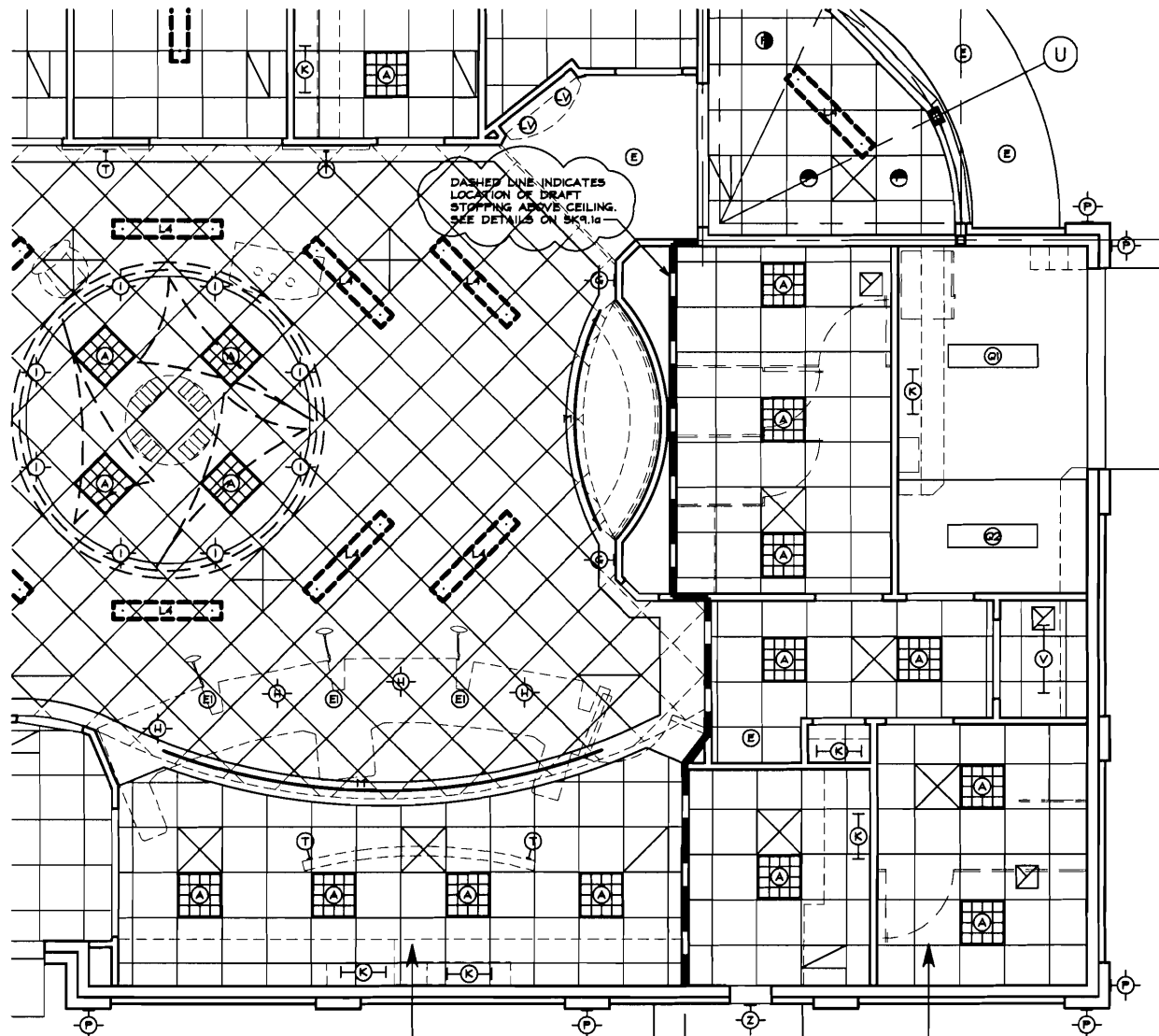

DRAFTSTOP AREA #1
2,525 S.F.

DRAFTSTOP AREA #2
595 S.F.

PARTIAL REFLECTED CEILING PLAN

1/8" = 1'-0"

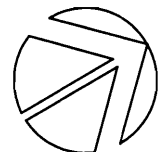

UNIVERSITY CREDIT UNION
1071 BRIGHTON AVENUE
PORTLAND, ME 04102
for
BRANDPARTNERS, INC.

THE ARCHITECT ASSUMES NO RESPONSIBILITY OR LIABILITY FOR THE USE OF THESE PLANS FOR ANY PROJECT OTHER THAN SPECIFICALLY AUTHORIZED BY THEM AND SIGNED AND SEALED FOR SUCH SPECIFIC LOCATION IN THE STATE SHOWN ON THE SEAL. THIS BUILDING USE IS ONLY APPLICABLE IN AREAS MEETING THE STATED DESIGN CRITERIA.

SHREMSHOCK ARCHITECTS, INC.
6130 S. Sunbury Rd. Suite 100 Westerville, OH 43081
Phone: (614) 545-4550 Fax: (614) 545-4555
email: arch@shremshock.com www.shremshock.com

DATE: 10/15/2007

SHEET REVISED: A&I

ISSUED WITH: FIELD SKETCH

PREPARED BY: CWV

SAI #: 07239

SHEET NUMBER:

SK8.1d

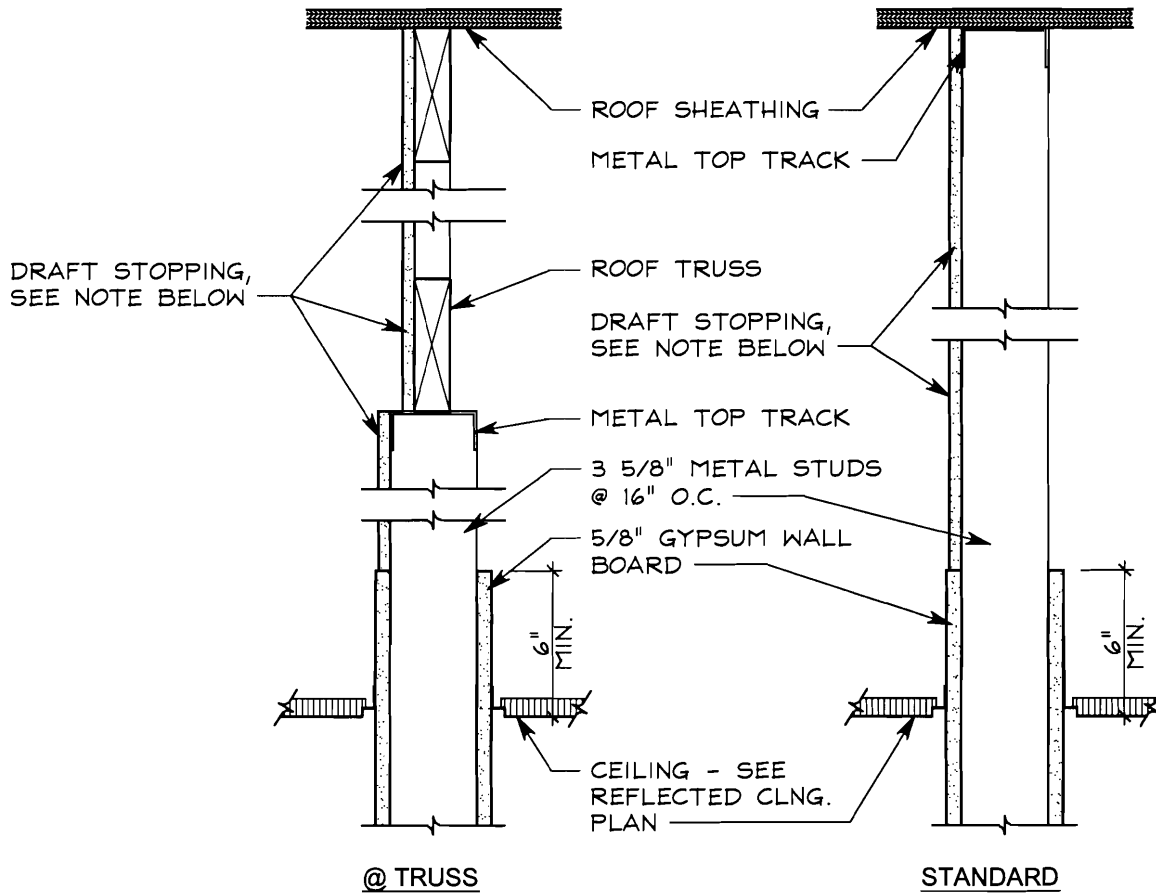

1/2" MIN. GYPSUM WALL BOARD OR O.S.B. DRAFT STOPPING TIGHT TO UNDERSIDE OF ROOF SHEATHING ABOVE. ALL PENETRATIONS SHALL BE APPROPRIATELY CAULKED OR SEALED AS REQUIRED TO INHIBIT THE TRANSFER OF SMOKE TO ADJACENT DRAFT STOPPED COMPARTMENTS

DRAFT STOPPING DETAILS

1-1/2" = 1'-0"

UNIVERSITY CREDIT UNION
 1071 BRIGHTON AVENUE
 PORTLAND, ME 04102
 for
BRANDPARTNERS, INC.

THE ARCHITECT ASSUMES NO RESPONSIBILITY OR LIABILITY FOR THE USE OF THESE PLANS FOR ANY PROJECT OTHER THAN SPECIFICALLY AUTHORIZED BY THEM AND SIGNED AND SEALED FOR SUCH SPECIFIC LOCATION IN THE STATE SHOWN ON THE SEAL. THIS BUILDING USE IS ONLY APPLICABLE IN AREAS MEETING THE STATED DESIGN CRITERIA.

SHREMSHOCK ARCHITECTS, INC.
 6130 S. Sunbury Rd. Suite 100 Westerville, OH 43081
 Phone: (614) 545-4550 Fax: (614) 545-4555
 email: arch@shremshock.com www.shremshock.com

DATE: 10/15/2007

SHEET REVISED: A91

ISSUED WITH: FIELD SKETCH

PREPARED BY: CWW

SAI #: 07239

SHEET NUMBER:

SK9.1a