

City of Portland, Maine - Building or Use Permit Application

389 Congress Street, 04101 Tel: (207) 874-8703, Fax: (207) 874-8716

Permit No: 04-1099	Issue Date:	CBL: 274 D002001
-----------------------	-------------	---------------------

Location of Construction: 2 Cabot St	Owner Name: Portland Housing Authority	Owner Address: 14 Baxter Blvd	Phone:
Business Name:	Contractor Name: Dempsey, Larry	Contractor Address: Portland	Phone:
Lessee/Buyer's Name	Phone:	Permit Type: HVAC	Zone:

Past Use: PHA Sagamore Village	Proposed Use: 2 Unit rentals install Replacement Boiler w/ Weil Mclean Boiler	Permit Fee: \$48.00	Cost of Work: \$2,900.00	CEO District: 3
Proposed Project Description: 2 Unit rentals install Weil Mclean Boiler		FIRE DEPT: <input type="checkbox"/> Approved <input type="checkbox"/> Denied <i>N/A</i>	INSPECTION: Use Group: <i>V</i> Type: <i>Heating</i> <i>State Gas Reg's</i>	
		Signature:	Signature:	

PEDESTRIAN ACTIVITIES DISTRICT (P.A.D.)	
Action: <input type="checkbox"/> Approved <input type="checkbox"/> Approved w/Conditions <input checked="" type="checkbox"/> Denied	Date:

Permit Taken By: Idobson	Date Applied For: 08/04/2004	Zoning Approval
-----------------------------	---------------------------------	------------------------

- This permit application does not preclude the Applicant(s) from meeting applicable State and Federal Rules.
- Building permits do not include plumbing, septic or electrical work.
- Building permits are void if work is not started within six (6) months of the date of issuance. False information may invalidate a building permit and stop all work..

Special Zone or Reviews	Zoning Appeal	Historic Preservation
<input type="checkbox"/> Shoreland <input type="checkbox"/> Wetland <input type="checkbox"/> Flood Zone <input type="checkbox"/> Subdivision <input type="checkbox"/> Site Plan Maj <input type="checkbox"/> Minor <input type="checkbox"/> MM <input type="checkbox"/> Date: <i>8/4/04</i>	<input type="checkbox"/> Variance <input type="checkbox"/> Miscellaneous <input type="checkbox"/> Conditional Use <input type="checkbox"/> Interpretation <input type="checkbox"/> Approved <input type="checkbox"/> Denied Date:	<input checked="" type="checkbox"/> Not in District or Landmark <input type="checkbox"/> Does Not Require Review <input type="checkbox"/> Requires Review <input type="checkbox"/> Approved <input type="checkbox"/> Approved w/Conditions <input type="checkbox"/> Denied Date: <i>8/4/04</i>

CERTIFICATION

I hereby certify that I am the owner of record of the named property, or that the proposed work is authorized by the owner of record and that I have been authorized by the owner to make this application as his authorized agent and I agree to conform to all applicable laws of this jurisdiction. In addition, if a permit for work described in the application is issued, I certify that the code official's authorized representative shall have the authority to enter all areas covered by such permit at any reasonable hour to enforce the provision of the code(s) applicable to such permit.

SIGNATURE OF APPLICANT	ADDRESS	DATE	PHONE
RESPONSIBLE PERSON IN CHARGE OF WORK, TITLE		DATE	PHONE

DIMENSIONS

CGi (Series 2) Gas Boiler

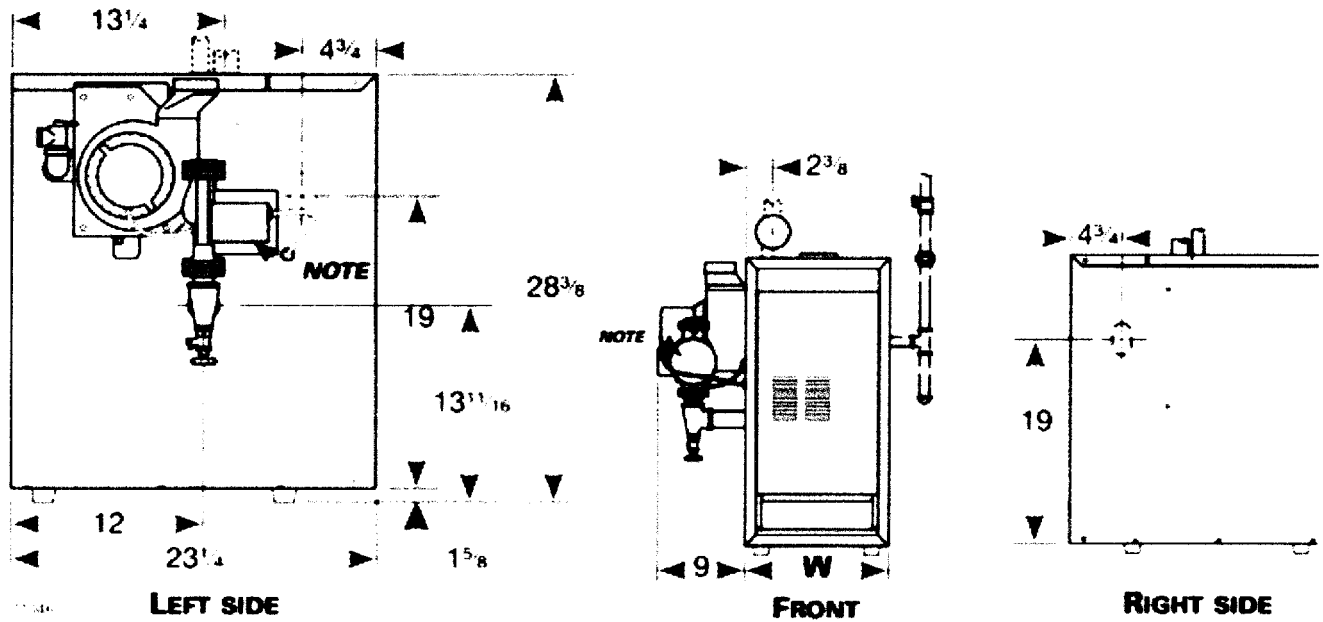

Boiler Model	Dimension Inches W	Supply Piping In. ¹	Return Piping In. ¹	Nat or LP Gas Connection Size Inches	Crate Dimensions (Outside Measurements - In.)		
					Length	Width	Heig
CGi-25	10	3/4	3/4	1/2	27	27 1/2	31 1.
CGi-3	10	1	1	1/2	27	27 1/2	31 1.
CGi-4	13	1	1	1/2	27	27 1/2	31 1.
CGi-5	16	1	1	1/2	30	27 1/2	31 1.
CGi-6	19	1 1/4	1 1/4	1/2	33	27 1/2	31 1.
CGi-7	22	1 1/4	1 1/4	3/4	36	27 1/2	31 1.
CGi-8	25	1 1/2	1 1/2	3/4	42	27 1/2	31 1.

1. Circulator flange supplied with boiler is same size as recommended pipe size. For supply and return boiler tapping size, see installation manual.

RATINGS

CGi (Series 2) Gas Boiler

Boiler Model¹	Input MBH²	DOE Heating Capacity MBH²	Net I=B=R Water Ratings MBH³	DOE Seasonal Efficiency Percent (AFUE)	Approx. Shipping Weight (Lbs)	Boiler Water Content (Gal)	Minimum Vent Connector Diameter
CGi-25	50	42	37	84.0	200	1.5	4" I.D.
CGi-3	67	57	50	84.3	200	1.5	4" I.D.
CGi-4	100	85	74	84.0	240	2.1	5" I.D.
CGi-5	133	112	97	83.7	280	2.7	5" I.D.
CGi-6	167	140	122	83.3	325	3.3	5" I.D.
CGi-7	200	167	145	83.0	370	3.8	5" I.D.
CGi-8	233	194	169	82.7	425	4.4	5" I.D.

1. Add "PIN" for natural gas; "PIL" for propane gas.
2. Based on standard test procedures prescribed by the United States Department of Energy.
3. Net I=B=R ratings are based on net installed radiation of sufficient quantity for the requirements of the building and nothing need be added for normal piping and pick-up. Ratings are based on a piping and pick-up allowance of 1.15. An additional allowance should be made for unusual piping and pick-up loads.
4. Refer to National Fuel Gas Code, ANSI Z223.1-latest edition, for chimney sizing and vent connector lengths.

CGi boilers are C.S.A. design certified for installation on combustible flooring. Tested for 50 psi working pressure.



FILL IN AND SIGN WITH INK

APPLICATION FOR PERMIT HEATING OR POWER EQUIPMENT

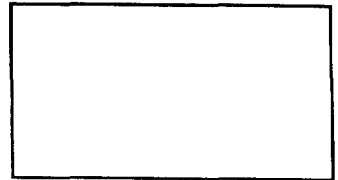

274000

To the INSPECTOR OF BUILDINGS, PORTLAND, ME.

The undersigned hereby applies for a permit to install the following heating, cooking or power equipment in accordance with the Laws of Maine, the Building Code of the City of Portland, and the following specifications:

Location / CBL 34 Josslyn St Use of Building Apartment Date 8/2/04

Name and address of owner of appliance PHA 14 Baxter Blvd Portland Me

Installer's name and address Larry Dempsey 16 Laurel Pines Drive Gorham Me

Telephone 839 7162

Location of appliance:

- Basement
- Attic
- Floor
- Roof

Type of Fuel:

- Gas
- Oil
- Solid

Appliance Name: Wail Mclean Boiler

U.L. Approved Yes No

Will appliance be installed in accordance with the manufacture's installation instructions? Yes No

IF NO Explain: _____

The Type of License of Installer:

- Master Plumber # 2453
- Solid Fuel # _____
- Oil # _____
- Gas # 2492
- Other _____

Type of Chimney:

- Masonry Lined
Factory built _____
- Metal
Factory Built U.L. Listing # _____
- Direct Vent
Type _____ UL# _____

Type of Fuel Tank

- Oil
- Gas

Size of Tank N/A

Number of Tanks N/A

Distance from Tank to Center of Flame N/A feet.

Cost of Work: \$ 2900.

Permit Fee: \$ 48.

Approved

Approved with Conditions

Fire: _____

Ele.: _____

Bldg.: _____

See attached letter or requirement

Inspector's Signature

Date Approved

Signature of Installer [Signature]

White - Inspection

Yellow - File

Pink - Applicant's

Gold - Assessor's Copy

City of Portland, Maine - Building or Use Permit

389 Congress Street, 04101 Tel: (207) 874-8703, Fax: (207) 874-8716

Permit No: 04-1099	Date Applied For: 08/04/2004	CBL: 274 D002001
------------------------------	--	----------------------------

Location of Construction: 2 Cabot St	Owner Name: Portland Housing Authority	Owner Address: 14 Baxter Blvd	Phone:
Business Name:	Contractor Name: Dempsey, Larry	Contractor Address: 16 Laurel Pines Drive Gorham	Phone (207) 839-7162
Lessee/Buyer's Name	Phone:	Permit Type: HVAC	

Proposed Use: 2 Unit rentals install Replacement Boiler w/ Weil Mclean Boiler in basement	Proposed Project Description: 2 Unit rentals install Weil Mclean Boiler
---	---

Dept: Zoning	Status: Approved	Reviewer: Tammy Munson	Approval Date: 08/04/2004
Note:			Ok to Issue: <input checked="" type="checkbox"/>
Dept: Building	Status: Approved with Conditions	Reviewer: Tammy Munson	Approval Date: 08/04/2004
Note:			Ok to Issue: <input checked="" type="checkbox"/>
1) The installation must comply with the State of Maine Gas Regulations.			
2) The installation must comply with the State of Maine Gas Regulations.			