

TECHNICAL SPECIFICATIONS

KG7S (C and L Series)

High Efficiency / Direct Vent
or Non Direct Vent Single Stage

Condensing Upflow/Horizontal and
Downflow Gas Furnaces

Induced Draft - 92.1 AFUE

Input 38,000 - 120,000 Btuh

The high efficiency upflow gas furnace may be installed free standing in a utility room, basement, or enclosed in an alcove or closet. Upflow/Horizontal units come ready for upflow or horizontal application. The extended flush jacket provides a pleasing "appliance appearance." Design certified by CSA for application in Canada and the United States.

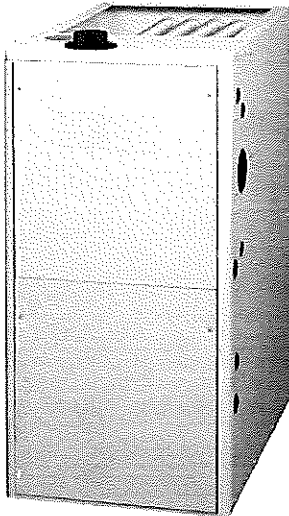

WARRANTY

- 10-year all-parts warranty.
- 1 Year Quality Pledge to replace the unit if the heat exchanger fails within the first year of operation, to the original owner.
- Consumer product registration required for 10 year All Parts Warranty and Quality Pledge within a limited period of time after the installation. See current warranty document or visit our consumer web site listed on the back of this document for warranty details.
- When registered, this product is upgraded to a limited lifetime heat exchanger warranty.

FEATURES and BENEFITS

- **100% fired and tested** — All units and each component are tested on the manufacturing line.
- **Best packaging in the industry** — Unique corner post design assures product will arrive to the homeowner dent free.
- **30 second blower delay** at start-up assures a warm duct temperature at furnace start-up. Adjustable blower off settings (60, 90, 120 and 180 seconds).
- **30 second post purge** increases life of heat exchanger.
- **Hot surface igniter** — Innovative application of an appliance type igniter with a 20 year history of reliability. Utilizes proven Smartlite® technology.
- **Color coded wire harness** — Designed to fit the components, all with quick-connect fittings for ease of service and replacement.
- **Flexible category IV venting system** — May be vertically or horizontally vented using either a one-pipe or two-pipe system for maximum flexibility in installation.
- **High Static Blowers** — All models equipped with high static blowers.
- **Low Boy Height** — Easy to apply in low ceiling applications, works well with taller high SEER coils, easier to handle and install.
- **Tubular primary heat exchanger** — Heavy gauge aluminized steel heat exchanger and stainless steel secondary heat exchanger assures a long life.
- **90 second fixed cooling cycle blower-off delay (TDR)** increases cooling performance when matched with a NORDYNE coil.
- **High efficiency blower kits** maximize efficiencies. On select units, a SEER improvement of up to 1 point is realized.
- **Multi-speed direct drive blower** — Designed to give a wide range of cooling capacities. Switches on PCB, provide ultra easy motor speed selection.
- **LP convertible** — Simple burner orifice and regulator spring change for ease of convertibility.
- **Diagnostic lights for easy troubleshooting without counting flashes** — Dedicated light for flame signal strength and 2 lights in combination to indicate all other fault codes with easy to recognize states without counting flashes.
- **Incorporates integrated control board** with connections for electronic air cleaner and humidifier.
- **Two piece door design** enhances furnace appearance and uses captured screws to prevent losing door screws.
- **Seated vestibule** reduces burner and inducer sound levels.

GAS FURNACE COMPONENTS

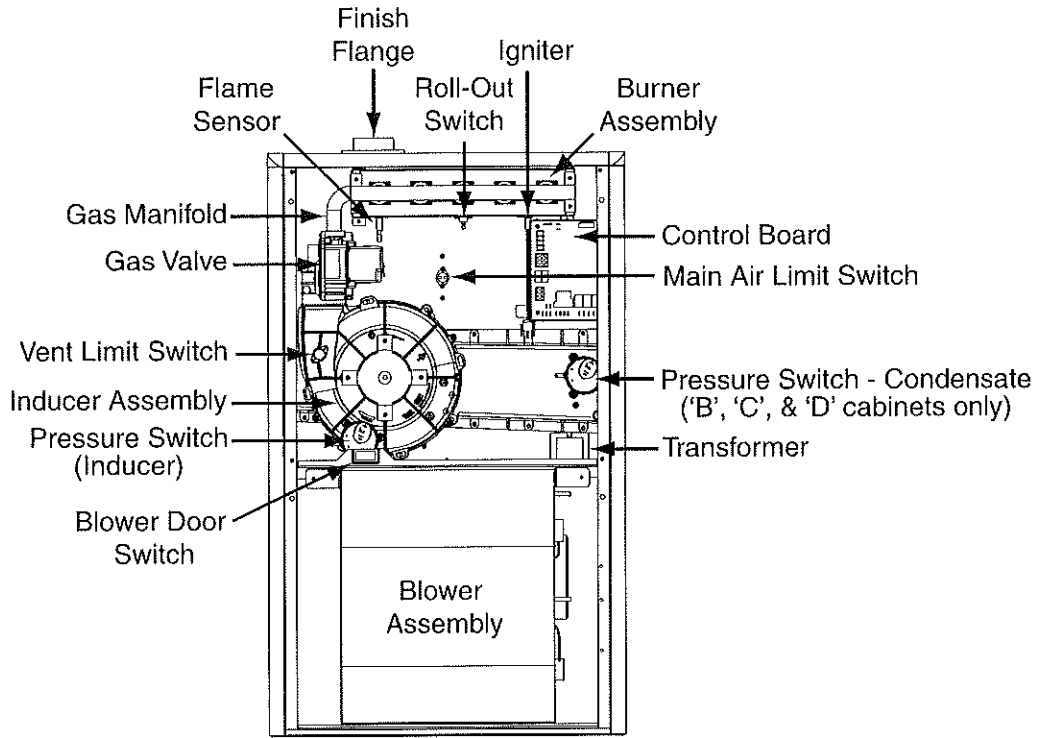

Upflow/Horizontal Gas Furnace

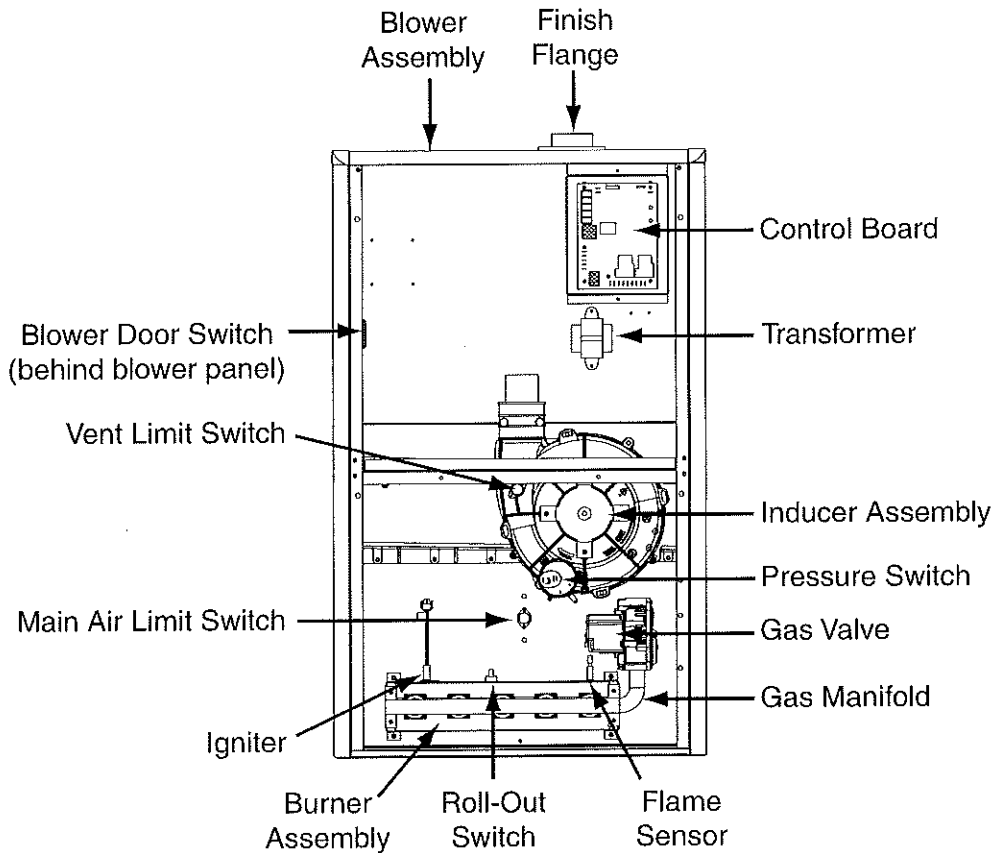

Downflow Gas Furnace

DIMENSIONS

*SC Model #'s	Dimension "A"	Dimension "B"	Dimension "C"
038D-23A	14 1/4	12 5/8	12 7/8
054D-24B	17 1/2	15 7/8	16 1/8
072D-24B			
072D-35C	21	19 3/8	19 5/8
090D-35C			
108D-45D	24 1/2	22 7/8	23 1/8
120D-45D			

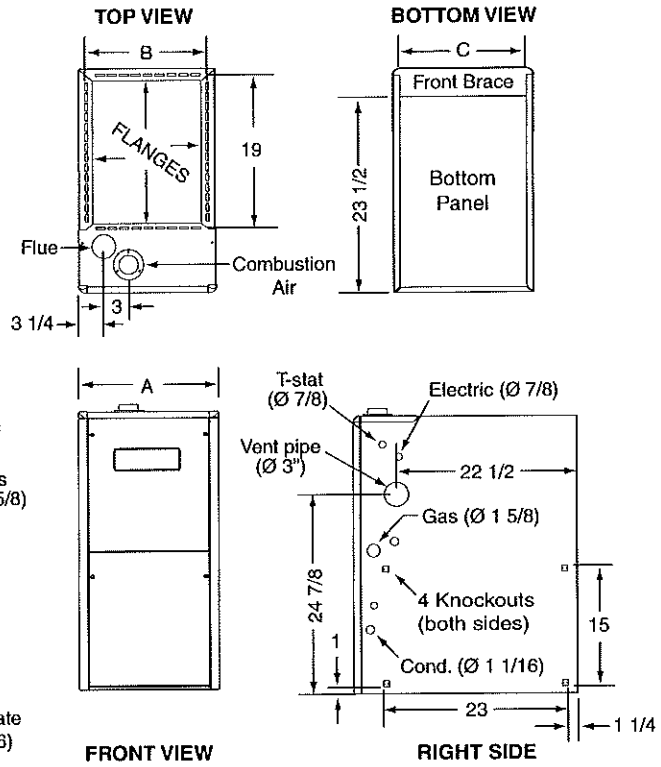

KG7SC 90+ High Efficiency Upflow/Horizontal Series

SL Model #'s	Dimension "A"	Dimension "B"	Dimension "C"
054D-24B	17 1/2	15 7/8	16 1/8
072D-24B			
090D-35C	21	19 3/8	19 5/8
120D-45D	24 1/2	22 7/8	23 1/8

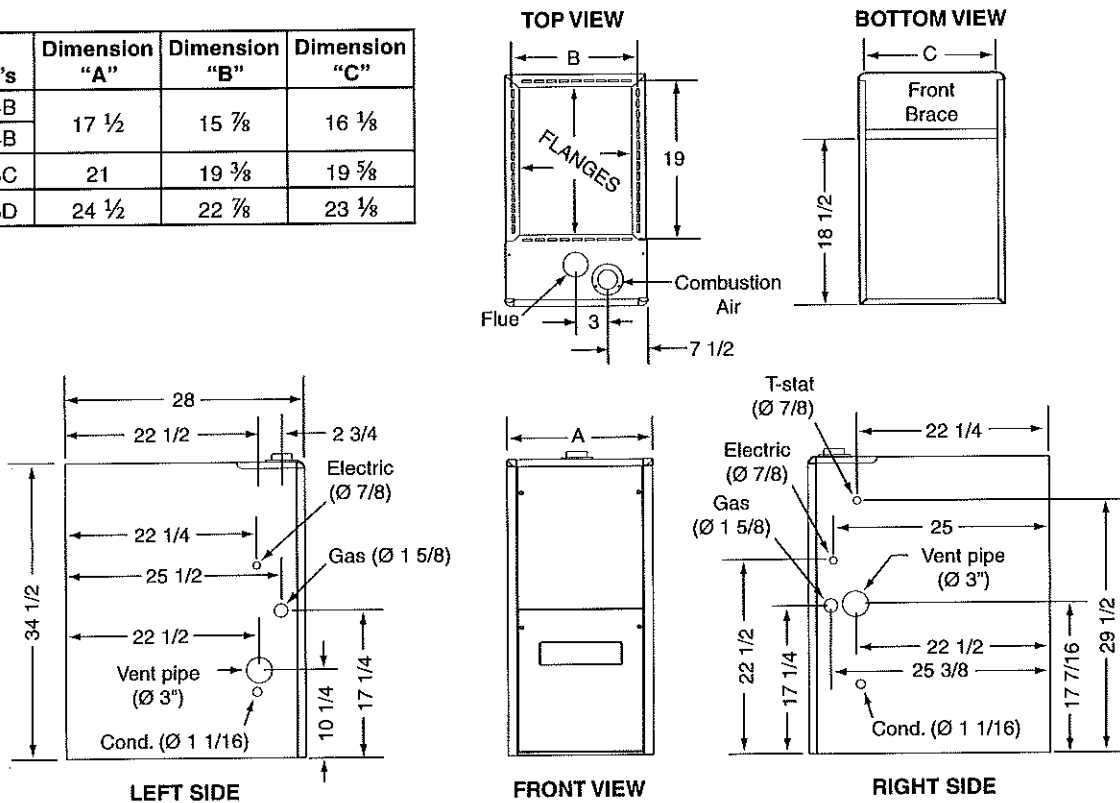

KG7SL 90+ High Efficiency Downflow Series

MODEL IDENTIFICATION CODE

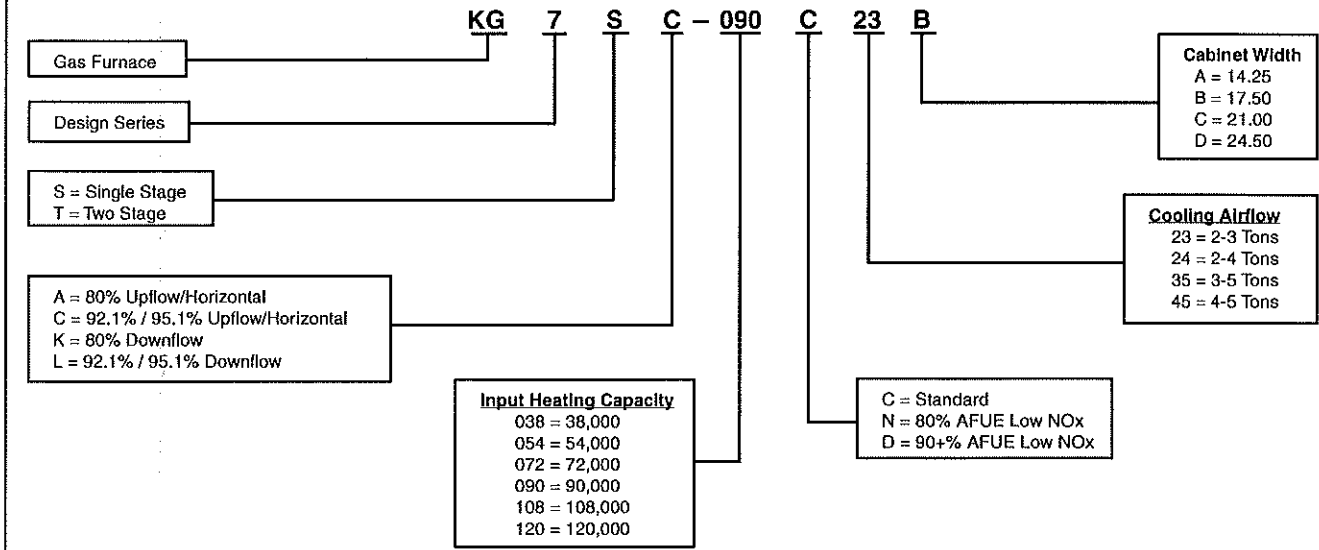

SPECIFICATIONS

KG7SC MODEL NUMBERS:	-038D-23A	-054D-24B	-072D-24B	-072D-35C	-090D-35C	-108D-45D	-120D-45D
Input - Btuh (a)	38,000	54,000	72,000	72,000	90,000	108,000	120,000
Heating Capacity - Btuh	35,000	49,700	66,000	66,000	82,800	99,000	110,400
AFUE	92.1	92.1	92.1	92.1	92.1	92.1	92.1
Blower D x W	10 x 6	11 x 8	11 x 8	10 x 10	11 x 10	11 x 10	11 x 10
Motor H.P. - Speed - Type	1/3 - 4 - PSC	1/2 - 4 - PSC	1/2 - 4 - PSC	1/2 - 4 - PSC	1.0 - 4 - PSC	1.0 - 4 - PSC	1.0 - 4 - PSC
Motor FLA	4.80	8.20	8.20	7.50	13.75	13.75	13.75
Rated Ext. SP - In. W.C.	0.5	0.5	0.5	0.5	0.5	0.5	0.5
Temperature Rise Range - °F	30-60	30-60	35-65	35-65	35-65	40-70	40-70
Shipping Weights	100lbs	120lbs	125lbs	130lbs	135lbs	155lbs	155lbs

KG7SL MODEL NUMBERS:	-054D-24B	-072D-24B	-090D-35C	-120D-45D
Input - Btuh (a)	54,000	72,000	90,000	120,000
Heating Capacity - Btuh	49,700	66,000	82,800	110,400
AFUE	92.1	92.1	92.1	92.1
Blower D x W	11 x 8	11 x 8	10 x 10	11 x 10
Motor H.P. - Speed - Type	1/2 - 4 - PSC	1/2 - 4 - PSC	1.0 - 4 - PSC	1.0 - 4 - PSC
Motor FLA	8.20	8.20	7.50	13.75
Rated Ext. SP - In. W.C.	0.5	0.5	0.5	0.5
Temperature Rise Range - °F	30-60	35-65	35-65	40-70
Shipping Weights	120lbs	125lbs	135lbs	155lbs

Note: All models are 115V, 60 Hz. Gas Connections are 1/2" N.P.T. AFUE = Annual Fuel Utilization Efficiency
 (a) Ratings to 2,000 ft. Over 2,000 ft. reduce 4% for each 1,000 ft. above sea level.

BLOWER PERFORMANCE - KG7SC

Model Number	Heating Input (Btuh)	Motor Speed	External Static Pressure (Inches Water Column)															
			0.1		0.2		0.3		0.4		0.5		0.6		0.7		0.8	
			CFM	Rise	CFM	Rise	CFM	Rise	CFM	Rise	CFM	Rise	CFM	Rise	CFM	Rise	CFM	Rise
SC038-23A Bottom Return	38,000	High*	1245	26	1200	27	1150	28	1100	29	1050	31	985	33	920	35	865	37
		Med-High	1115	29	1075	30	1030	31	990	33	935	35	880	37	815	40	740	44
		Med-Low**	785	41	770	42	745	43	720	45	680	48	640	51	595	54	530	61
		Low	645	50	630	51	610	53	580	56	555	58	525	62	480	67	420	77
SC038-23A Side Return	38,000	High*	1330	24	1285	25	1230	26	1175	28	1125	29	1055	31	985	33	925	35
		Med-High	1195	27	1150	28	1100	29	1060	31	1000	32	940	34	875	37	790	41
		Med-Low**	840	39	825	39	800	40	770	42	730	44	685	47	640	51	560	58
		Low	680	48	675	48	655	49	620	52	600	54	560	58	515	63	450	72
SC054-24B Bottom Return	54,000	High*	1550	30	1520	30	1485	31	1450	32	1410	33	1360	34	1300	35	1255	37
		Med-High	1250	37	1220	38	1200	38	1170	39	1140	40	1105	42	1065	43	1010	46
		Med-Low**	935	49	910	51	880	52	850	54	815	56	785	59	735	63	680	68
		Low	720	64	690	67	655	70	620	74	585	79	550	84	520	88	485	95
SC054D-24B Side Return	54,000	High*	1630	28	1595	29	1560	29	1525	30	1480	31	1430	32	1365	34	1320	35
		Med-High	1315	35	1280	36	1260	37	1230	37	1200	38	1160	40	1120	41	1060	43
		Med-Low**	980	47	955	48	925	50	890	52	855	54	825	56	775	59	715	64
		Low	755	61	725	63	690	67	650	71	615	75	580	79	545	84	510	90
SC072D-24B Bottom Return	72,000	High*	1590	39	1550	40	1525	40	1475	42	1425	43	1380	44	1325	46	1240	49
		Med-High**	1260	49	1240	49	1220	50	1185	52	1160	53	1110	55	1085	57	1030	60
		Med-Low	1125	55	1110	55	1085	57	1050	58	1025	60	990	62	940	65	865	71
		Low	895	69	865	71	830	74	795	77	775	79	750	82	693	89	665	92
SC072D-24B Side Return	72,000	High*	1670	37	1630	38	1600	38	1550	40	1495	41	1450	42	1390	44	1300	47
		Med-High**	1325	46	1300	47	1280	48	1245	49	1220	50	1165	53	1140	54	1080	57
		Med-Low	1180	52	1165	53	1140	54	1100	56	1075	57	1040	59	985	62	910	67
		Low	940	65	910	67	870	70	835	74	805	78	770	82	730	86	640	96
SC072D-35C Bottom Return	72,000	High*	1895	32	1790	34	1720	36	1630	38	1550	40	1445	42	1330	46	1225	50
		Med-High**	1775	35	1710	36	1650	37	1550	40	1470	42	1385	44	1290	48	1180	52
		Med-Low	1255	49	1200	51	1155	53	1105	56	1050	58	1000	61	925	66	830	74
		Low	1140	54	1100	56	1065	58	1025	60	980	63	930	66	870	70	805	76
SC072D-35C Side Return	72,000	High*	1970	31	1865	33	1780	34	1695	36	1615	38	1505	41	1385	44	1275	48
		Med-High**	1845	33	1780	34	1715	36	1615	38	1530	40	1440	43	1340	46	1230	50
		Med-Low	1305	47	1250	49	1200	51	1150	53	1090	56	1040	59	965	64	865	71
		Low	1185	52	1145	54	1110	55	1065	58	1020	60	965	64	905	68	840	73
SC072D-35C Side + Bottom or 2 Sides	72,000	High*	1990	31	1880	33	1805	34	1710	36	1630	38	1510	41	1400	44	1285	48
		Med-High**	1865	33	1795	34	1735	35	1630	38	1545	40	1455	42	1355	45	1240	49
		Med-Low	1320	46	1260	49	1215	50	1160	53	1105	56	1050	58	970	63	875	70
		Low	1200	51	1155	53	1120	55	1075	57	1030	60	975	63	915	67	845	73
SC090D-35C Bottom Return	90,000	High*	2155	36	2090	37	2015	38	1960	39	1910	40	1835	42	1755	44	1660	46
		Med-High**	2015	38	1960	39	1920	40	1860	41	1805	42	1755	44	1695	45	1615	47
		Med-Low	1705	45	1675	46	1640	47	1590	48	1555	49	1495	51	1435	53	1340	57
		Low	1410	54	1390	55	1365	56	1330	58	1310	59	1275	60	1235	62	1210	63
SC090D-35C Side Return	90,000	High*	2240	34	2175	35	2100	37	2040	38	1985	39	1910	40	1825	42	1725	44
		Med-High**	2095	37	2040	38	2000	38	1935	40	1875	41	1825	42	1765	43	1680	46
		Med-Low	1775	43	1740	44	1705	45	1655	46	1615	47	1555	49	1490	51	1335	57
		Low	1465	52	1445	53	1420	54	1385	55	1360	56	1325	58	1285	60	1260	61
SC090D-35C Side + Bottom or 2 Sides	90,000	High*	2265	34	2195	35	2115	36	2060	37	2005	38	1930	40	1845	42	1745	44
		Med-High**	2115	36	2060	37	2015	38	1955	39	1895	40	1845	42	1780	43	1695	45
		Med-Low	1790	43	1760	44	1725	44	1670	46	1635	47	1570	49	1510	51	1410	54
		Low	1480	52	1460	53	1435	53	1400	55	1375	56	1340	57	1300	59	1270	60
SC108D-45D Bottom only or 2 openings	108,000	High*	2135	43	2095	44	2040	45	1975	47	1910	48	1840	50	1735	53	1675	55
		Med-High**	2000	46	1955	47	1900	48	1845	50	1800	51	1735	53	1665	55	1570	59
		Med-Low	1665	55	1660	55	1625	57	1590	58	1530	60	1500	61	1415	65	1340	69
		Low	1385	66	1360	68	1310	70	1300	71	1275	72	1250	74	1200	77	1150	80
SC108D-45D Side Return	108,000	High*	2115	43	2075	44	2020	46	1955	47	1890	49	1822	50	1720	53	1660	55
		Med-High**	1980	46	1935	48	1880	49	1830	50	1780	52	1720	53	1650	56	1555	59
		Med-Low	1650	56	1645	56	1610	57	1575	58	1515	61	1485	62	1400	66	1330	69
		Low	1370	67	1345	68	1300	71	1290	71	1260	73	1240	74	1190	77	1140	81
SC120D-45D Bottom only or 2 openings	120,000	High*	2135	48	2095	49	2040	50	1975	52	1910	54	1840	56	1735	59	1675	61
		Med-High**	2000	51	1955	52	1900	54	1845	55	1800	57	1735	59	1665	61	1570	65
		Med-Low	1665	61	1660	62	1625	63	1590	64	1530	67	1500	68	1415	72	1340	76
		Low	1385	74	1360	75	1310	78	1300	79	1275	80	1250	82	1200	85	1150	89
SC120D-45D Side Return	120,000	High*	2115	48	2075	49	2020	51	1955	52	1890	54	1822	56	1720	59	1660	62
		Med-High**	1980	52	1935	53	1880	54	1830	56	1780	57	1720	59	1650	62	1555	66
		Med-Low	1650	62	1645	62	1610	63	1575	65	1515	67	1485	69	1400	73	1330	77
		Low	1370	75	1345	76	1300	79	1290	79	1260	81	1240	82	1190	86	1140	90

* Factory Set Cooling Speed
 ** Factory Set Heating Speed

NOTE: 1. 2 openings are recommended for airflows above 1600 CFM if filter(s) is (are) adjacent to furnace.
 2. Temperature rises in the table are approximate. Actual temperature rises may vary.
 3. Temperature rises shaded grey are for reference only. These conditions are not recommended.

BLOWER PERFORMANCE - KG7SL

Model Number	Heating Input (Btuh)	Motor Speed	External Static Pressure (Inches Water Column)																	
			0.1		0.2		0.3		0.4		0.5		0.6		0.7		0.8			
			CFM	Rise	CFM	Rise	CFM	Rise	CFM	Rise	CFM	Rise	CFM	Rise	CFM	Rise	CFM	Rise		
SL054D-24B	54,000	HIGH*	1580	29	1550	30	1520	30	1485	31	1460	32	1425	32	1375	33	1320	35		
		MED-HIGH	1240	37	1230	37	1210	38	1185	39	1165	39	1135	41	1100	42	1045	44		
		MED-LOW**	1145	40	1120	41	1100	42	1080	43	1055	44	1030	45	985	47	940	49		
SL072D-24B	72,000	LOW	895	51	870	53	850	54	825	56	800	58	770	60	740	62	715	64		
		HIGH*	1560	39	1530	40	1500	41	1480	41	1435	43	1400	44	1360	45	1310	47		
		MED-HIGH**	1245	49	1225	50	1205	51	1180	52	1150	53	1125	55	1090	56	1045	59		
SL090D-35C	90,000	MED-LOW	1085	57	1070	57	1045	59	1025	60	1000	61	970	63	930	66	880	70		
		LOW	850	72	830	74	800	77	780	79	760	81	730	84	710	86	685	90		
		HIGH*	1955	39	1905	40	1835	42	1795	43	1730	44	1620	47	1545	50	1450	53		
SL120D-45D	120,000	MED-HIGH**	1845	42	1790	43	1750	44	1680	46	1515	51	1540	50	1475	52	1410	54		
		MED-LOW	1320	58	1290	59	1250	61	1215	63	1180	65	1120	68	1050	73	970	79		
		LOW	1190	64	1165	66	1125	68	1080	71	1055	73	1000	77	945	81	875	88		
SL120D-45D	120,000	HIGH*	2215	46	2150	48	2075	49	2035	50	1970	52	1905	54	1800	57	1745	59		
		MED-HIGH**	2050	50	2015	51	1955	52	1900	54	1860	55	1795	57	1720	59	1620	63		
		MED-LOW	1720	59	1690	60	1655	62	1640	62	1610	63	1560	66	1505	68	1465	70		
LOW	1420	72	1410	72	1400	73	1365	75	1350	76	1335	77	1290	79	1260	81				

NOTE: 1. Temperature rises in the table are approximate. Actual temperature rises may vary.
 2. Temperature rises shaded grey are for reference only. These conditions are not recommended.

* Factory Set Cooling Speed
 ** Factory Set Heating Speed

VENTING

All models are approved for vertical non direct (1 pipe) and direct (2 pipe) venting applications. See Vent Table below for specified sizes and allowable lengths.

VENT TABLE

MODELS	SINGLE PIPE LENGTH (FT.) with 1 long radius elbow*		DIRECT VENT, DUEL PIPE LENGTH (ft.) WITH 1 long radius elbow on each pipe*	
	OUTLET	OUTLET	INLET/OUTLET	INLET/OUTLET
	2"	3"	2"	3"
SC038	50	70	50	70
SC054	70	90	70	90
SC072	50	90	50	90
SC090	60	90	60	90
SC108	N/A	90	N/A	90
SC120	N/A	90	N/A	90
SL054	70	90	70	90
SL072	50	90	50	90
SL090	60	90	60	90
SL120	N/A	90	N/A	90

* NOTE:

1. Subtract 2.5 ft. for each additional 2" elbow and 3.5 ft. for each additional 3" elbow.
2. Two 45 degree elbows are equivalent to one 90 degree elbow.
3. One short radius elbow is equivalent to two long radius elbows.
4. Do not include termination elbows in calculation of vent length.
5. This table is applicable for elevations from sea level to 2000 ft. For higher elevations decrease vent pipe lengths by 8% per 1000 ft. of altitude.
6. Only the listed pipe materials are approved for use with KG7 Condensing Furnaces.

ACCESSORIES

KG7S (C, L) KITS	
Description	SKU
"A" Cabinet fixed speed, high efficiency, FSHE	904872
"B" Cabinet fixed speed, high efficiency, FSHE	904873
"C" Cabinet fixed speed, high efficiency, FSHE	904874
"D" Cabinet fixed speed, high efficiency, FSHE	904875
"A" Cabinet variable speed, high efficiency, VSHE	904876
"B" Cabinet variable speed, high efficiency, VSHE	904877
"C" Cabinet variable speed, high efficiency, VSHE	904878
"D" Cabinet variable speed, high efficiency, VSHE	904879
2" Concentric vent kit	904952
3" Concentric vent kit	904953
"A" Cabinet downflow sub base kit	902974
"B", "C", "D" Cabinet downflow sub base kit	904911
2" Side wall vent kit	904617
3" Side wall vent kit	904347
U.S. LP Conversion kit (0 to 10,000 ft.)	905028
Canada LP Conversion kit (0 to 4,500 ft.)	905029
Bottom return filter 20 per box, "A" cabinet	903088
Bottom return filter 20 per box, "B" cabinet	904916
Bottom return filter 20 per box, "C" cabinet	904917
Bottom return filter 20 per box, "D" cabinet	904918
Side return filter kit	541036
Neutralizer kit	902377



GENERAL TERMS OF LIMITED WARRANTY

NORDYNE will furnish a replacement for any part of this product which fails in normal use and service within the first ten years of installation, in accordance with the terms of the warranty.

For complete details of the Limited Warranty, including applicable terms and conditions, see your local installer or contact the NORDYNE warranty department for a copy.

NORDYNE

COMPLETE COMFORT. GENUINE VALUE.

8000 Phoenix Parkway | O'Fallon, MO 63368-3827

Specifications and illustrations subject to change without notice and without incurring obligations. Printed in U.S.A (01/2012)

729C-0112 (Replaces 729C-1011)