

City of Portland, Maine - Building or Use Permit Application

389 Congress Street, 04101 Tel: (207) 874-8703, Fax: (207) 874-8716

Permit No: 09-1177	Issue Date:	CBL: 273 C017001
-----------------------	-------------	---------------------

Location of Construction: 172 TAFT AVE	Owner Name: KELLEY RICHARD A & RUTH S	Owner Address: 8 HASKELL ST	Phone:
Business Name:	Contractor Name: Jason Crockett	Contractor Address: 70 Seaview Ave OOB	Phone 2078995474
Lessee/Buyer's Name	Phone:	Permit Type: HVAC	Zone: R3

Past Use: Single Family Home	Proposed Use: Single Family Home - install a Rinnai RHFE 263 RFA w/ a 74 Gallon tank	Permit Fee: \$40.00	Cost of Work: \$1,600.00	CEO District: 3
		FIRE DEPT: <input type="checkbox"/> Approved <input type="checkbox"/> Denied	INSPECTION: HVAC Use Group: R3 Type: SB IRC 2003 ST ME GAS Regulations	

Proposed Project Description: install a Rinnai RHFE 263 RFA w/ a 74 Gallon tank	Signature:	Signature: <i>Jm 10/27/09</i>
PEDESTRIAN ACTIVITIES DISTRICT (P.A.D.)		
Action: <input type="checkbox"/> Approved <input type="checkbox"/> Approved w/Conditions <input type="checkbox"/> Denied		
Signature:		Date:

Permit Taken By: Ldobson	Date Applied For: 10/26/2009	Zoning Approval
-----------------------------	---------------------------------	------------------------

<p>1. This permit application does not preclude the Applicant(s) from meeting applicable State and Federal Rules.</p> <p>2. Building permits do not include plumbing, septic or electrical work.</p> <p>3. Building permits are void if work is not started within six (6) months of the date of issuance. False information may invalidate a building permit and stop all work..</p>	<p>Special Zone or Reviews</p> <input type="checkbox"/> Shoreland <input type="checkbox"/> Wetland <input type="checkbox"/> Flood Zone <input type="checkbox"/> Subdivision <input type="checkbox"/> Site Plan Maj <input type="checkbox"/> Minor <input type="checkbox"/> MM <input type="checkbox"/> Date: <i>9/10/26/09</i>	<p>Zoning Appeal</p> <input type="checkbox"/> Variance <input type="checkbox"/> Miscellaneous <input type="checkbox"/> Conditional Use <input type="checkbox"/> Interpretation <input type="checkbox"/> Approved <input checked="" type="checkbox"/> Denied Date:	<p>Historic Preservation</p> <input checked="" type="checkbox"/> Not in District or Landmark <input type="checkbox"/> Does Not Require Review <input type="checkbox"/> Requires Review <input type="checkbox"/> Approved <input type="checkbox"/> Approved w/Conditions <input type="checkbox"/> Denied Date:
	<p><i>ok with conditions</i></p>		

CERTIFICATION

PERMIT ISSUED

I hereby certify that I am the owner of record of the named property, or that the proposed work is authorized by the owner of record and that I have been authorized by the owner to make this application as his authorized agent and I agree to conform to all applicable laws of this jurisdiction. In addition, if a permit for work described in the application is issued, I certify that the code official's authorized representative shall have the authority to enter all areas covered by such permit at any reasonable hour to enforce the provision of the code(s) applicable to such permit.

OCT 26 2009

City of Portland

SIGNATURE OF APPLICANT	ADDRESS	DATE	PHONE
RESPONSIBLE PERSON IN CHARGE OF WORK, TITLE		DATE	PHONE



FILL IN AND SIGN WITH INK

APPLICATION FOR PERMIT HEATING OR POWER EQUIPMENT

PERMIT ISSUED

OCT 26 2009

City of Portland

To the INSPECTOR OF BUILDINGS, PORTLAND, ME.

The undersigned hereby applies for a permit to install the following heating, cooking or power equipment in accordance with the Laws of Maine, the Building Code of the City of Portland, and the following specifications:

Location / CBL 273-C-17 Use of Building SFH Date 10-26-09
 Name and address of owner of appliance Stephen Kelly 172 Taff Ave,
 Installer's name and address Jason Crockett 70 Seaview Ave. OOB ME 04064
XX mail Telephone 877-5474

Location of appliance:
 Basement Floor
 Attic Roof

Type of Fuel:
 Gas Oil Solid

Appliance Name: Rinnai RHFE 263 RFA
 U.L. Approved Yes No

Will appliance be installed in accordance with the manufacture's installation instructions? Yes No

IF NO Explain: _____

The Type of License of Installer:
 Master Plumber # _____
 Solid Fuel # _____
 Oil # _____
 Gas # _____
 Other _____

Type of Chimney:
 Masonry Lined
 Factory built _____

Metal
 Factory Built U.L. Listing # _____

Direct Vent
 Type _____ UL# _____

Type of Fuel Tank
 Oil
 Gas

Size of Tank 74 gal

Number of Tanks 1

Distance from Tank to Center of Flame 20 feet.

Cost of Work: \$ 1600
 Permit Fee: \$ 40

RECEIVED
 OCT 26 2009
 Dept. of Building Inspections
 City of Portland Maine

Approved

Approved with Conditions

Fire: _____
 Ele.: _____
 Bldg.: _____

See attached letter or requirement

Inspector's Signature

Date Approved

Signature of Installer Jason Crockett

City of Portland, Maine - Building or Use Permit

389 Congress Street, 04101 Tel: (207) 874-8703, Fax: (207) 874-8716

Permit No: 09-1177	Date Applied For: 10/26/2009	CBL: 273 C017001
------------------------------	--	----------------------------

Location of Construction: 172 TAFT AVE	Owner Name: KELLEY RICHARD A & RUTH S	Owner Address: 8 HASKELL ST	Phone:
Business Name:	Contractor Name: Jason Crockett	Contractor Address: 70 Seaview Ave OOB	Phone (207) 899-5474
Lessee/Buyer's Name	Phone:	Permit Type: HVAC	

Proposed Use: Single Family Home - install a Rinnai RHFE 263 RFA w/ a 74 Gallon tank	Proposed Project Description: install a Rinnai RHFE 263 RFA w/ a 74 Gallon tank
--	---

Dept: Zoning **Status:** Approved with Conditions **Reviewer:** Marge Schmuckal **Approval Date:** 10/26/2009

Note: **Ok to Issue:**

- 1) Separate permits shall be required for future decks, sheds, pools, and/or garages.
- 2) This is NOT an approval for an additional dwelling unit. You SHALL NOT add any additional kitchen equipment including, but not limited to items such as stoves, microwaves, refrigerators, or kitchen sinks, etc. Without special approvals.
- 3) This property shall remain a single family dwelling. Any change of use shall require a separate permit application for review and approval.
- 4) This permit is being approved on the basis of plans submitted. Any deviations shall require a separate approval before starting that work.

Dept: Building **Status:** Approved with Conditions **Reviewer:** Tom Markley **Approval Date:** 10/29/2009

Note: **Ok to Issue:**

- 1) The installation must comply with the State of Maine Gas Regulations.
- 2) Application approval based upon information provided by applicant. Any deviation from approved plans requires separate review and approval prior to work.

PERMIT ISSUED

OCT 26 2009

City of Portland



ES11 (RHFE-263RFA)

Energysaver[®]

Gas Direct Vent Wall Furnace

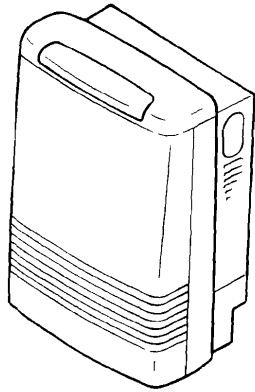

Table of Contents	2
Safety Information.....	3
Operating Instructions.....	6
Care and Maintenance....	10
Fault Codes	13
Installation Instructions ...	14
Consumer Support.....	40

WARNING: If the information in these instructions is not followed exactly, a fire or explosion may result causing property damage, personal injury or loss of life.

— Do not store or use gasoline or other flammable vapors and liquids in the vicinity of this or any other appliance.

WHAT TO DO IF YOU SMELL GAS

- Do not try to light any appliance.
- Do not touch any electrical switch; do not use any phone in your building.
- Immediately call your gas supplier from a neighbor's phone. Follow the gas supplier's instructions.
- If you cannot reach your gas supplier, call the fire department.

— Installation and service must be performed by a qualified installer, service agency or the gas supplier.

INSTALLER: Leave this manual with the appliance.
CONSUMER: Retain this manual for future reference.

Register your product at www.rinnairregistration.com or call 1-866-RINNAI1 (746-6241)

Rinnai[®]

Dimension Kit Installation

CAUTION Use the pipe stoppers, connectors, clamps, and screws according to these instructions in order to ensure no leakage of exhaust gases.

- exhaust pipe to combustibles
- exhaust pipe to non-combustibles

1 inch (25.4mm)

zero

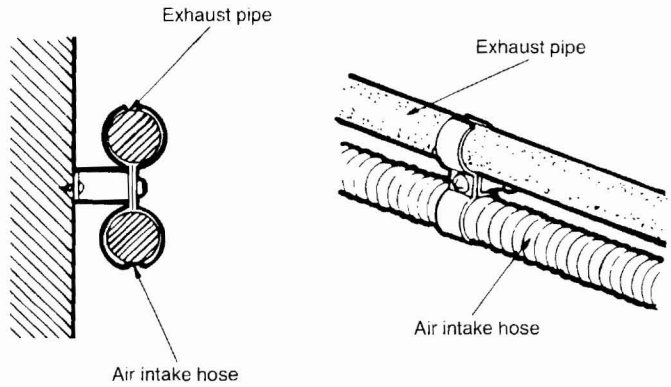

NOTES

The exhaust line and air intake hose are supported by clamps which are attached to the wall. The wall fixture can be used to offset the clamp from the wall. Use Screw B to attach the wall fixture to the wall. If the wall fixture is not used then use Screw A and the nut to attach the clamp to the wall. The air intake hose should always be underneath the exhaust line so that in case the air line sags it will not come into contact with the exhaust line.

Installing the Exhaust Line

The exhaust line is connected between the bent pipe near of the heater and the exhaust port on the manifold. Connect exhaust pipes with other straight pipes or elbows. Fit the male end into the female end. Use pipe clamp A to clamp the connection. Use pipe stopper B to fix the length on the adjustable pipes. Do not extend these pipes beyond the manifold.

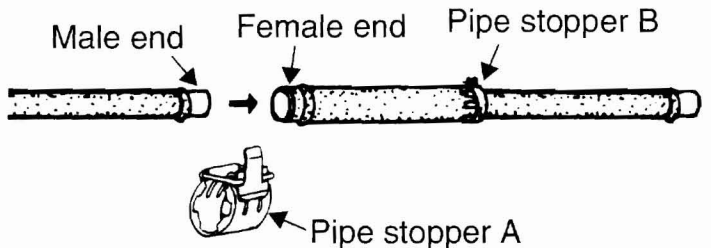

Fit the exhaust pipe. Use the adjustable pipe if necessary. At the elbow, insert exhaust pipes into both sides for additional leverage. Bend to desired angle. Straighten the bent pipe attached to the manifold.

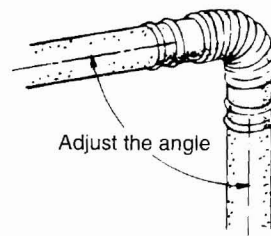

Connecting the Air Intake Hose

The air intake hose is connected between the air intake port at the rear of the heater and the air intake port on the flue manifold. Fit the air intake hose onto the flue manifold and secure it with the plastic cable tie. Support the air intake hoses by screwing the hose joint half of the clamp into the air intake hose and then screwing the other half of the air intake hose into the hose joint.

The lengths of the air intake hose and the exhaust pipe must be the same in order for the appliance to operate properly. The hose can be cut to the required length. Deburr all rough edges. Do not cut the hose attached to the appliance.

Support the air intake hose with pipe clamps.

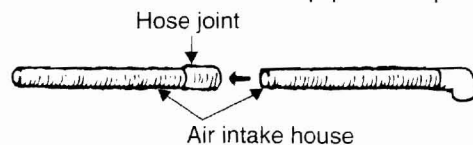

Flue Manifold Installation

4. Install the Terminal

Check that the terminal seal is in place. For weatherboard walls, add the second seal next to the terminal seal to compensate for weather board angle.

From the outside insert the terminal into the sleeve with the marking "TOP" at the top. The left hand side locking tie should be marked "LEFT".

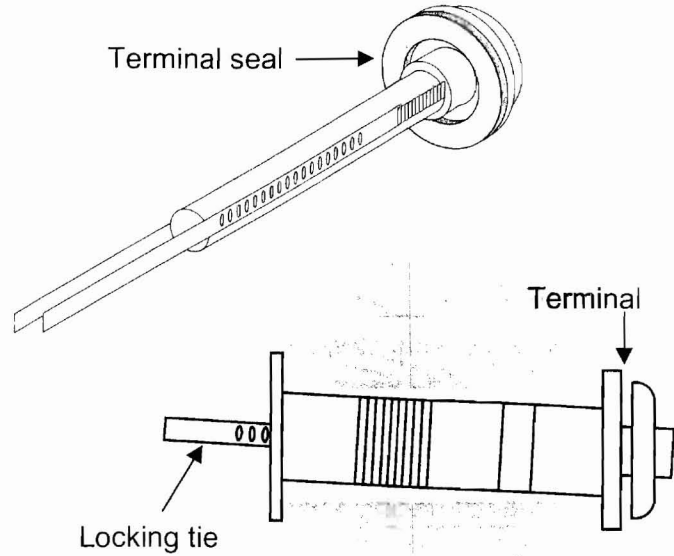

6. Lock the ties

Pulling hard on the left and right hand ties, clip the ties over the notches inside the sleeve. You should be able to pull the ties 2 or 3 notches past the starting point. Cut the ties, leaving about 3/4 inch (20 mm) past the notch. Bend the ties back into the sleeve and parallel to the wall.

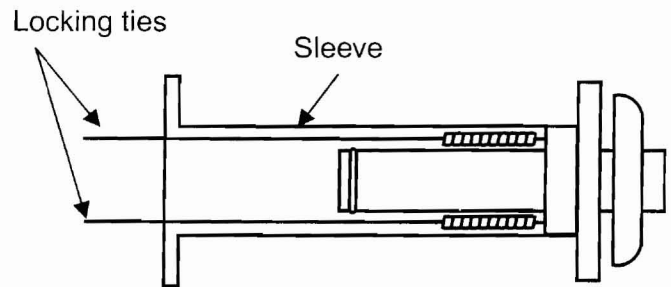

7. Insert Inside Connection Assembly

Push the assemble into the terminal tube, ensuring that the seal is in place on the inner tube.

Attach the inside connection with 3 screws. The inner connection can still be turned to install the screws.

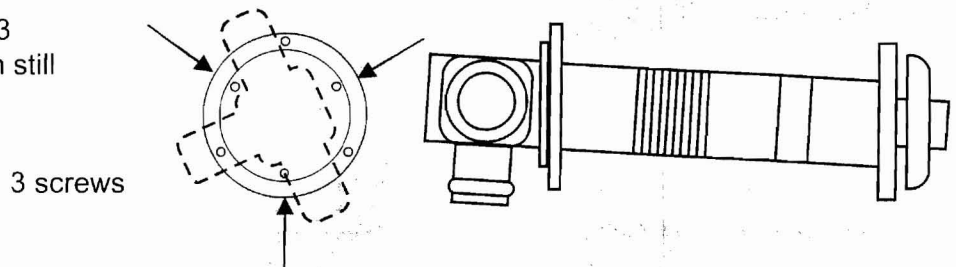

**BOUNDARY SURVEY OF LAND AT 172 TAFT AVENUE,
PORTLAND, MAINE**

MADE FOR STEPHEN KELLEY
10 HASKELL STREET, WESTBROOK, MAINE 04092

MADE BY NORTHEASTERN LAND SURVEYING
16 COLLEGE AVENUE, GORHAM, MAINE 04038

JULY 3, 2009 JOB #09-010 SHEET 1 OF 1

SCALE 1"=20'



NOTES:

- 1) OWNER OF RECORD IS STEPHEN KELLEY.
- 2) THE DEEDS OF RECORD ARE RECORDED IN THE CUMBERLAND COUNTY REGISTRY OF DEEDS IN BOOK 28476 PAGE 122 AND BOOK 1981 PAGE 303.
- 3) THE CADASTRAL REFERENCE IS CITY OF PORTLAND TAX MAP 873 BLOCK C LOTS 17 AND 18.
- 4) ZONING: THE PARCEL IS IN THE "R3" ZONE. CURRENT ZONING, STATUS, AND REQUIREMENTS MUST BE CHECKED AND VERIFIED WITH THE CITY OF PORTLAND AND ALL OTHER APPLICABLE REGULATORY BODIES BEFORE BUILDING IMPROVEMENTS OR CONVEYING LAND OR INTEREST.
- 5) ROAD RIGHT OF WAY WIDTH AND LOCATION IS PER REFERENCE PLAN #1.
- 6) THE WESTERLY BOUND OF LOT 258 ON REFERENCE PLAN #1 IS "THE LOCATION AS NOW STAKED OF PROPOSED PORTLAND TERMINAL". FIELD EVIDENCE AS WELL AS PLAN READINGS AND DISTANCES WERE USED TO CALCULATE AN ESTIMATE OF THE CURVE RADIUS INTENDED.
- 7) THE PARCEL DOES NOT FALL IN A "SPECIAL FLOOD HAZARD AREA" PER F.E.M.A. SEE COMMUNITY #230051 PANEL #0006, EFFECTIVE DATE DECEMBER 8, 1996.
- 8) UTILITY LOCATION SHOWN IS APPROXIMATE. THIS PLAN MAY NOT SHOW ALL UTILITIES USED OR IN DISUSE. ALL APPROPRIATE OFFICERS AND THE DIGSAFE PROGRAM SHOULD BE CONTACTED BEFORE DOING ANY EXCAVATION.
- 9) THIS PLAN IS NOT INTENDED TO DEPICT LIMITS OR EXTENTS OF FEE TITLE OWNERSHIP. AN OPINION OF TITLE SHOULD BE RENDERED BY AN ATTORNEY.
- 10) NORTHEASTERN LAND SURVEYING AND THE SIGNING SURVEYOR RESERVE THE RIGHT TO BE HELD HARMLESS FROM ALL THIRD PARTY CLAIMS.

PLAN REFERENCE:

- 1) "PORTLAND GARDENS" IN THE CITY OF PORTLAND, MAINE. OWNED BY J.W. WILBUR. DATED JULY 1, 1912. BY A.L. ELIOT C.E. RECORDED IN THE CUMBERLAND COUNTY REGISTRY OF DEEDS IN PLAN BOOK 12 PAGE 23.

Proposed 79' x 41'

N/T
MARGARET YARBANPARI
08/26/76
170 TAFT AVENUE
TH 873/C/17

N/T
DUC T. RUYNE AND
MAI T. RUYNE
18107/81
170 HOLL AVENUE
TH 873/B/24

N/T
KROGHTE V. SYLVESTER
18007/81
170 HOLL AVENUE
TH 873/B/23

N/T
JANIS FLANNERY AND
KENNETH ACTON
0828/91
180 TAFT AVENUE
TH 873/C/19-20

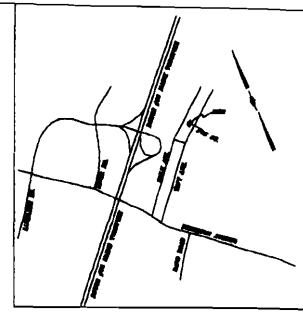

JUL 14 2009

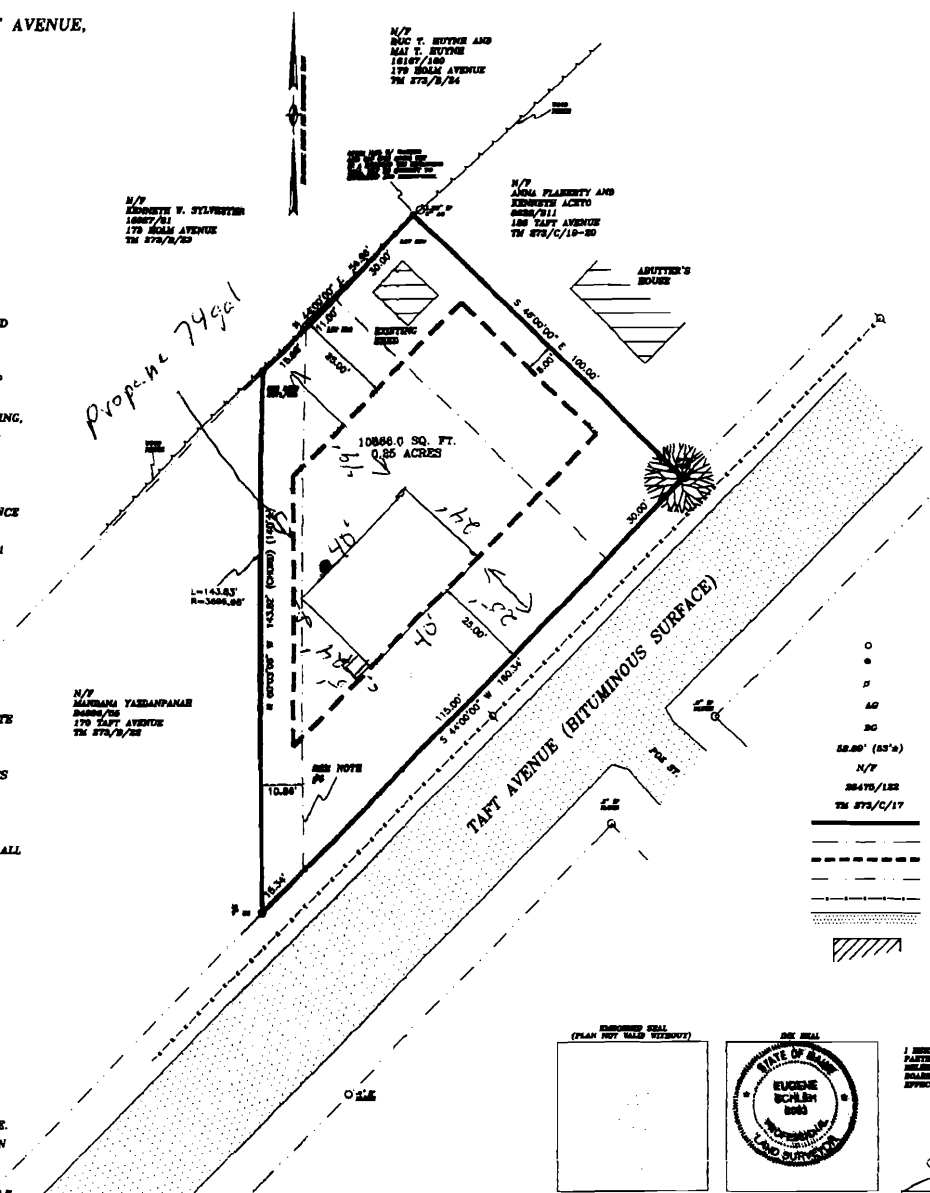

LEGEND

- IRON PIPE/ROD FOUND (FP/RF)
- IRON ROD SET WITH CAP (FR BOSS)
- ⊕ UTILITY POLE
- AG ABOVE GRADE
- BG BELOW GRADE
- 18.80' (85'±) FOUND DISTANCE (RECORD DISTANCE)
- N/T NOW OR FORMERLY OF
- 28476/122 CUMBERLAND COUNTY REGISTRY OF DEEDS BOOK/PAGE NUMBER
- TH 873/C/17 TAX MAP/LOT/BLOCK NUMBER
- SURVEYED PROPERTY LINE
- - - - - FORMER LINE OF DIVISION
- - - - - BUILDING SETBACK LINE
- - - - - APPROXIMATE PROPERTY LINE (NOT SURVEYED)
- OVERHEAD UTILITY LINE
- BITUMINOUS PAVEMENT
- ▨ EXISTING BUILDINGS

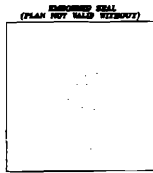

I HEREBY STATE TO BE TRUE AND CORRECT AND EXCLUSIVE OF ALL OTHER PARTIES, THAT TO THE BEST OF MY KNOWLEDGE, INFORMATION AND BELIEF THIS PLAN ACCURATELY REPRESENTS THE ACTUAL SURVEY AND MEASUREMENTS FOR PROFESSIONAL LAND SURVEYING UNDER EXECUTIVE ORDER 1, 2004.

[Signature]
GEOFFREY P. BROWN
GEO SURVEYOR PLS 8002

COPYRIGHT 2009 NORTHEASTERN LAND SURVEYING
ALL RIGHTS RESERVED

STATE OF MAINE CHIMNEY OR FIREPLACE CONSTRUCTION/INSTALLATION DISCLOSURE

Dear Consumer: State law, specifically 32 M.R.S.A. § 2313-A, requires that chimney or fireplace installers, as of January 1, 1992, provide you with this "Disclosure" prior to the installation or construction of your chimney or fireplace. The purpose of this Disclosure is to inform you that the National Fire Protection Standard #211 (NFPA #211) is the current standard which applies to all new construction of chimneys and fireplaces. Please note that the State of Maine does not require registration or licensure of chimney or fireplace installers. It is important to realize that many fires are caused each year from improperly constructed fireplaces and chimneys. This disclosure form should help you in making an informed decision as to the abilities of the installer and under what requirements the installation must comply.

INSTALLER INFORMATION

Name of Installer: <i>Robert Christensen</i>		D/B/A: <i>Christensen</i>	
Name of Installer (if incorporated):		D/B/A:	
Legal Address: <i>732 Highland Ave</i>			
City: <i>So. Portland</i>	State: <i>ME</i>	Zip Code: <i>04106</i>	
County: <i>Cumberland</i>		Home Telephone: <i>(207) 798 - 4358</i>	
		Work Telephone: <i>(207) 837 - 3034</i>	
Years of experience doing fireplace or chimney installations: <i>35 years</i>			

CONSUMER INFORMATION

Name of Consumer: <i>Stephen Keller</i>		
Mailing Address: <i>172 Tappan Ave</i>		
City: <i>Portland</i>	State: <i>ME</i>	Zip Code: <i>04102</i>
County:		Home Telephone: <i>(207) 252 - 5173</i>
		Work Telephone: () -

Installer, please give a brief description of installation being offered: _____
Single flue chimney

I hereby attest that the preceding information provided is true to the best of my knowledge. I also understand that if I fail to conform with the standards as outlined in NFPA #211 that I shall be subject to penalties as outlined in Title 32, M.R.S.A., Chapter 33 and the Oil and Solid Fuel Board Rules.

Signature of Installer: *Robert Christensen* Date: *10-21-08*

10-28-09

Installed /snr /close