

DISPLAY THIS CARD ON PRINCIPAL FRONTAGE OF WORK
CITY OF PORTLAND

Please Read
 Application And
 Notes, If Any,
 Attached

BUILDING INSPECTION

PERMIT

PERMIT ISSUED

Permit Number: 10491

This is to certify that Zweifel Robert H &/Chimney Sweeps of the Finest Kind/John Shaw
 has permission to Adding a Napoleon wood stove to a pre-existing wood stove chimney structure.

AT 68 Birchvale Dr CBL 272 0007001 City of Portland

provided that the person or persons, firm or corporation accepting this permit shall comply with all of the provisions of the Statutes of Maine and of the Ordinances of the City of Portland regulating the construction, maintenance and use of buildings and structures, and of the application on file in this department.

Apply to Public Works for street line and grade if nature of work requires such information.

Notification of inspection must be given and written permission procured before this building or part thereof is lathed or otherwise closed-in. 24 HOUR NOTICE IS REQUIRED.

A certificate of occupancy must be procured by owner before this building or part thereof is occupied.

OTHER REQUIRED APPROVALS

Fire Dept. _____

Health Dept. _____

Appeal Board _____

Other _____

Department Name

Director - Building & Inspection Services

PENALTY FOR REMOVING THIS CARD



CITY OF PORTLAND, MAINE
Department of Building Inspections

Original Receipt

Dec. 2 2010

Received from Robert Zweifel

Location of Work 66 Buckvale

Cost of Construction \$ _____ Building Fee: _____

Permit Fee \$ _____ Site Fee: _____

Certificate of Occupancy Fee: _____

Total: 50.00

Building (IL) _____ Plumbing (IS) _____ Electrical (I2) _____ Site Plan (U2) _____

Other _____

CBL: 2720007

Check #: Viper Total Collected \$ 50.00

**No work is to be started until permit issued.
Please keep original receipt for your records.**

Taken by: Hayle

WHITE - Applicant's Copy
YELLOW - Office Copy
PINK - Permit Copy

BUILDING PERMIT INSPECTION PROCEDURES

Please call 874-8703 or 874-8693 (ONLY)

or email: buildinginspections@portlandmaine.gov

With the issuance of this permit, the owner, builder or their designee is required to provide adequate notice to the City of Portland Inspection Services for the following inspections. Appointments must be requested 48 to 72 hours in advance of the required inspection. The inspection date will need to be confirmed by this office.

- **Please read the conditions of approval that is attached to this permit!! Contact this office if you have any questions.**
- **Permits expire in 6 months, if the project is not started or ceases for 6 months.**
- **If the inspection requirements are not followed as stated below additional fees may be incurred due to the issuance of a "Stop Work Order" and subsequent release to continue with construction.**

 X **Framing/Rough Plumbing/Electrical: Prior to Any Insulating, drywalling or covering.**

 X **Final inspection required at completion of work.**

The project cannot move to the next phase prior to the required inspection and approval to continue, REGARDLESS OF THE NOTICE OR CIRCUMSTANCES.

IF THE PERMIT REQUIRES A CERTIFICATE OF OCCUPANCY, IT MUST BE PAID FOR AND ISSUED TO THE OWNER OR DESIGNEE BEFORE THE SPACE MAY BE OCCUPIED.

City of Portland, Maine - Building or Use Permit

389 Congress Street, 04101 Tel: (207) 874-8703, Fax: (207) 874-8716

Permit No: 10-1491	Date Applied For: 12/02/2010	CBL: 272 0007001
-----------------------	---------------------------------	---------------------

Location of Construction: 68 Birchvale Dr	Owner Name: Zweifel Robert H &	Owner Address: 68 Birchvale Dr	Phone: 207-541-7538
Business Name:	Contractor Name: Chimney Sweeps of the Finest Kind/	Contractor Address: 12 Eighth Street Portland	Phone: (207) 797-6634
Lessee/Buyer's Name	Phone:	Permit Type: Alterations - Dwellings	

Proposed Use: Single Family / Adding a Napoleon wood stove to a pre-existing wood stove chimney structure.	Proposed Project Description: Adding a Napoleon wood stove to a pre-existing wood stove chimney structure.
---	---

Dept: Zoning **Status:** Approved with Conditions **Reviewer:** Marge Schmuckal **Approval Date:** 12/02/2010

Note: **Ok to Issue:**

- 1) Separate permits shall be required for future decks, sheds, pools, and/or garages.
- 2) This is NOT an approval for an additional dwelling unit. You SHALL NOT add any additional kitchen equipment including, but not limited to items such as stoves, microwaves, refrigerators, or kitchen sinks, etc. Without special approvals.
- 3) This property shall remain a single family dwelling. Any change of use shall require a separate permit application for review and approval.
- 4) This permit is being approved on the basis of plans submitted. Any deviations shall require a separate approval before starting that work.

Dept: Building **Status:** Approved with Conditions **Reviewer:** Jonathan Rioux **Approval Date:** 12/23/2010

Note: **Ok to Issue:**

- 1) This solid fuel appliance/stove/insert shall be installed, operated and maintained per the manufacturers specifications, the UL listing, State of Maine Solid Fuel Board Laws, NFPA 211 and IMC 2003.
- 2) A copy of the enclosed chimney or fireplace disclosure must be submitted to this office upon completion of the permitted work or for the Certificate of Occupancy.

City of Portland, Maine - Building or Use Permit Application

389 Congress Street, 04101 Tel: (207) 874-8703, Fax: (207) 874-8716

Permit No: 10-1491	Issue Date:	CBL: 272 0007001
-----------------------	-------------	---------------------

Location of Construction: 68 Birchvale Dr	Owner Name: Zweifel Robert H &	Owner Address: 68 Birchvale Dr	Phone: 207-541-7538
Business Name:	Contractor Name: Chimney Sweeps of the Finest Kind/	Contractor Address: 12 Eighth Street Portland	Phone: 2077976634
Lessee/Buyer's Name	Phone:	Permit Type: Alterations - Dwellings	Zone: R-3

Past Use: Single Family	Proposed Use: Single Family / Adding a Napoleon wood stove to a pre-existing wood stove chimney structure.	Permit Fee: \$50.00	Cost of Work: \$2,037.00	CEO District: 3
		FIRE DEPT: U/A <input type="checkbox"/> Approved <input type="checkbox"/> Denied	INSPECTION: Use Group: R3 Type: HVAC NFPA 211 IRC 2003	

Proposed Project Description:
Adding a Napoleon wood stove to a pre-existing wood stove chimney structure.

Signature: _____
Signature: _____
PEDESTRIAN ACTIVITIES DISTRICT (P.A.D.)
Action: Approved Approved w/Conditions Denied
Signature: _____ Date: _____

Permit Taken By: gg	Date Applied For: 12/02/2010	Zoning Approval	
------------------------	---------------------------------	------------------------	--

<p>1. This permit application does not preclude the Applicant(s) from meeting applicable State and Federal Rules.</p> <p>2. Building permits do not include plumbing, septic or electrical work.</p> <p>3. Building permits are void if work is not started within six (6) months of the date of issuance. False information may invalidate a building permit and stop all work..</p>	<p>Special Zone or Reviews</p> <input type="checkbox"/> Shoreland <input type="checkbox"/> Wetland <input type="checkbox"/> Flood Zone <input type="checkbox"/> Subdivision <input type="checkbox"/> Site Plan Maj <input type="checkbox"/> Minpr <input type="checkbox"/> MM <input type="checkbox"/> Date: <i>ok with conditions</i> <i>9/24/10</i>	<p>Zoning Appeal</p> <input type="checkbox"/> Variance <input type="checkbox"/> Miscellaneous <input type="checkbox"/> Conditional Use <input type="checkbox"/> Interpretation <input type="checkbox"/> Approved <input type="checkbox"/> Denied Date: _____	<p>Historic Preservation</p> <input checked="" type="checkbox"/> Not in District or Landmark <input type="checkbox"/> Does Not Require Review <input type="checkbox"/> Requires Review <input type="checkbox"/> Approved <input type="checkbox"/> Approved w/Conditions <input type="checkbox"/> Denied Date: _____
---	---	---	--

PERMIT ISSUED

DEC 29 2010

City of Portland

CERTIFICATION

I hereby certify that I am the owner of record of the named property, or that the proposed work is authorized by the owner of record and that I have been authorized by the owner to make this application as his authorized agent and I agree to conform to all applicable laws of this jurisdiction. In addition, if a permit for work described in the application is issued, I certify that the code official's authorized representative shall have the authority to enter all areas covered by such permit at any reasonable hour to enforce the provision of the code(s) applicable to such permit.

SIGNATURE OF APPLICANT ADDRESS DATE PHONE

RESPONSIBLE PERSON IN CHARGE OF WORK, TITLE DATE PHONE



General Building Permit Application

If you or the property owner owes real estate or personal property taxes or user charges on any property within the City, payment arrangements must be made before permits of any kind are accepted.

66 Birchvale Dr.

Location/Address of Construction: <i>68 Birchvale Dr</i>			Total Square Footage of Proposed Structure/Area <i>16 sq ft</i>	Square Footage of Lot <i>7,448.76</i>	Number of Stories <i>Split Level</i>
Tax Assessor's Chart, Block & Lot Chart# Block# Lot# <i>272 000 7661</i>	Applicant *must be owner, Lessee or Buyer* Name <i>Robert Zweifel</i> Address <i>68 Birchvale Dr</i> City, State & Zip <i>Portland, ME 04107</i>			Telephone: <i>207-541-9538</i>	
Lessee/DBA (If Applicable)	Owner (if different from Applicant) Name Address City, State & Zip			Cost Of Work: \$ <i>2,037.00</i>	C of O Fee: \$ <i>50.00</i>
RECEIVED DEC - 2 2010 Dept. of Building Inspections City of Portland Maine					
Current legal use (i.e. single family) <i>Single Family</i>		Number of Residential Units <i>1</i>			
If vacant, what was the previous use? _____					
Proposed Specific use: <i>Single Family</i>					
Is property part of a subdivision? _____ If yes, please name _____					
Project description: <i>No Pole out</i> <i>Adding a wood stove to a pre-existing wood stove chimney structure.</i>					
Contractor's name: <i>John Shaw / Chimney Sweeps of the Finest Kind</i>					
Address: _____					
City, State & Zip _____				Telephone: _____	
Who should we contact when the permit is ready: <i>Robert Zweifel</i>				Telephone: <i>207-541-9538</i>	
Mailing address: <i>68 Birchvale Dr, Portland ME 04107</i>					

Please submit all of the information outlined on the applicable Checklist. Failure to do so will result in the automatic denial of your permit.

In order to be sure the City fully understands the full scope of the project, the Planning and Development Department may request additional information prior to the issuance of a permit. For further information or to download copies of this form and other applications visit the Inspections Division on-line at www.portlandmaine.gov, or stop by the Inspections Division office, room 315 City Hall or call 874-8703.

I hereby certify that I am the Owner of record of the named property, or that the owner of record authorizes the proposed work and that I have been authorized by the owner to make this application as his/her authorized agent. I agree to conform to all applicable laws of this jurisdiction. In addition, if a permit for work described in this application is issued, I certify that the Code Official's authorized representative shall have the authority to enter all areas covered by this permit at any reasonable hour to enforce the provisions of the codes applicable to this permit.

Signature: *Robert Zweifel* Date: *12/2/10*

This is not a permit; you may not commence ANY work until the permit is issued

Robert Zweifel
68 Birchvale Dr, Portland, ME 04102

Adding a wood stove to a pre-existing wood stove chimney structure.

Floor Plan: Basement View

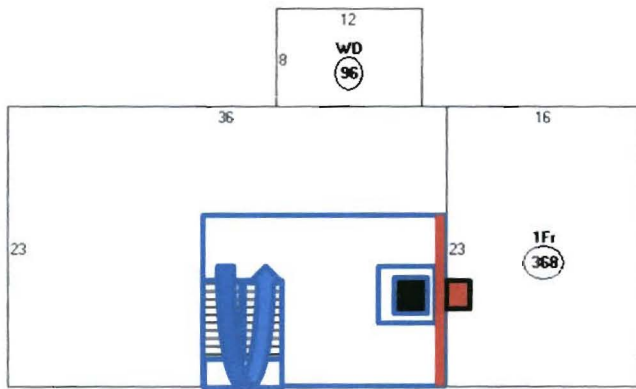

Descriptor/Area

A: ---
828 sqft
B: w/D
96 sqft
C: 1Fr
368 sqft

Floor Plan: Elevation View

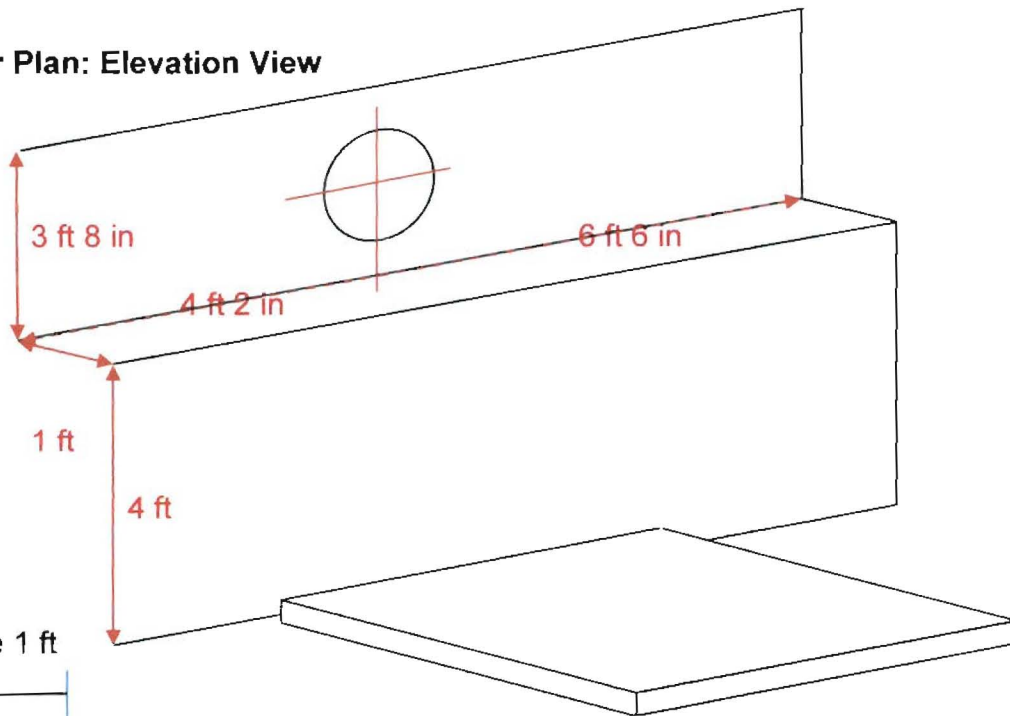

Scale 1 ft

Robert Zweifel
68 Birchvale Dr, Portland, ME 04102

Adding a wood stove to a pre-existing wood stove chimney structure.

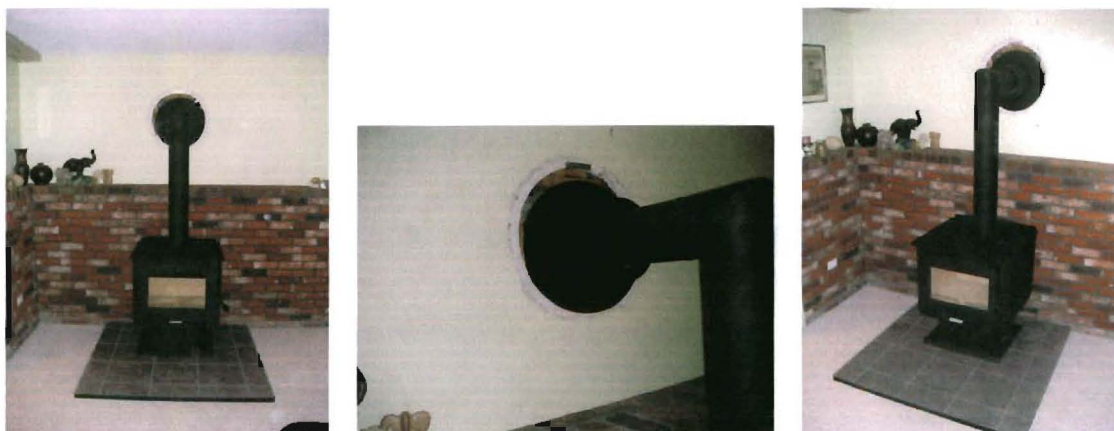

Robert Zweifel
68 Birchvale Dr, Portland, ME 04102

Itemized Charges

Invoice /Sale	Date	Amt
502	10/11/10	\$ 1,205.93
543	11/06/10	\$ 501.90
FSTLANE3 13	10/24/10	\$ 29.40
INSTALL*	?	<u>\$ 300.00</u>
	Total=	\$ 2,037.23

*Install was quoted by Chimney Sweeps of the Finest Kind / John Shaw but has not yet been billed.



Embers Stove and Fireplaces

581 Main Street
South Portland, ME 04106

Invoice

Date	Invoice #
10/11/2010	502

Bill To

PAID

ROBERT ZWEIFEL
68 BIRCHVALE DR
PORTLAND, ME 04102
207-541-9538

Description	Qty	Rate	Amount
1450 wood stove	1	999.00	999.00T
T&A 6x12" pipe	2	20.40	40.80T
T&A 6" slip pipe	1	34.20	34.20T
Pip 1&A 6x24	1	26.60	26.60T
T&A 6" slip elbow	1	47.90	47.90T

Subtotal \$1,148.50

Sales Tax (5.0%) \$57.43

Total \$1,205.93

Payments/Credits \$-1,205.93

Balance Due \$0.00

**Installation Labor is Paid
directly to the Installer**

Phone #	Fax #	E-mail	Web Site
207-221-8242	207-221-8244	info@embersstoveshop.com	www.embersstoveshop.com

Embers Stove and Fireplaces

Invoice

EMBERS STOVES N
FIREPLACES
581 MAIN ST
SOUTH PORTLAND, ME 04106
(207) 221-8242

Main Street
Portland, ME 04106

Date	Invoice #
11/6/2010	543

COPY

11/06/2010 13:35:00

Sale:

Transaction # 1
 Card Type: Visa
 Acc: *****0592
 Entry: Swiped
 Total: 501.90

Reference No.: 014602526
 Auth.Code: 08721B
 Response: APPROVAL 08721B
 Sequence Number: 0001
 CUSTOMER COPY

Description	Qty	Rate	Amount
AJ hearth mat 48x48 gray metal band	1	295.00	295.00T
ITH insulated wall pass thru	1	183.00	183.00T

Subtotal	\$478.00
Sales Tax (5.0%)	\$23.90
Total	\$501.90
Payments/Credits	\$0.00
Balance Due	\$501.90

**Installation Labor is Paid
directly to the Installer**

Phone #	Fax #	E-mail	Web Site
207-221-8242	207-221-8244	info@embersstoveshop.com	www.embersstoveshop.com

LOWE'S
LOWE'S HOME CENTERS, INC
1058 BRIGHTON AVENUE
PORTLAND, ME 04102 (207) 482-2800

- SALE -

SALES #: FSTLANE3 13 10-24-10

39244 9X9 CHIMNEY CAP (HYC) 28.00

SUBTOTAL: 28.00

TAX: 1.40

INVOICE 06161 TOTAL: 29.40

VISA: 29.40

VISA:XXXXXXXXXX0592 AMOUNT:29.40 AUTHCD:064248
REFID:803999773 10/24/10 10:32:15
STORE: 1946 TERMINAL: 06 10/24/10 10:32:25
OF ITEMS PURCHASED: 1
EXCLUDES FEES, SERVICES AND SPECIAL ORDER ITEMS



THANK YOU FOR SHOPPING LOWE'S.
SEE REVERSE SIDE FOR RETURN POLICY.
STORE MANAGER: JEN

HAVE A COMMENT OR FEEDBACK? LET US KNOW AT:
WWW.LOWES.COM/FEEDBACK
STORE CODE: 19461-02410-06161

WE HAVE THE LOWEST PRICES, GUARANTEED!
IF YOU FIND A LOWER PRICE, WE WILL BEAT IT BY 10%.
SEE STORE FOR DETAILS.

NOTICE: Drywall Settlement. Read Below.

Lowe's has settled a lawsuit alleging that certain drywall purchased from Lowe's was defective and caused property damage and/or personal injury. Lowe's denies all of these claims. You are included in the Class if you have or had allegedly defective drywall that was purchased from Lowe's anytime before 7/27/10.

Class Members may receive from \$50 to \$4,500 in Lowe's gift cards and cash. To get a payment, you must submit a claim form by 5/18/11.

Unless you exclude yourself from the Class by 11/9/10, you give up the right to ever sue Lowe's about the legal claims this settlement resolves. If you stay in the Class, you may object to the settlement by 11/9/10.

The Court will hold a hearing on 11/19/10, to consider whether to approve the settlement and attorney's fees of up to \$2.166 million. You may ask to appear and speak at the hearing.

For more information about the settlement, including how to get benefits, exclude yourself or object, go to www.DrywallSettlement.info or call 1-877-497-3512.

INSTALLER: LEAVE THIS MANUAL WITH THE APPLIANCE
CONSUMER: RETAIN THIS MANUAL FOR FUTURE REFERENCE



INSTALLATION AND OPERATION INSTRUCTIONS

CERTIFIED UNDER U.S. ENVIRONMENTAL PROTECTION AGENCY (E.P.A.) JULY 1990 AND THE OREGON DEPARTMENT OF ENVIRONMENTAL QUALITY (D.E.Q.) PARTICULATE EMISSION STANDARDS BY E.E.M.C. THESE STOVES HAVE BEEN TESTED AND LISTED BY INTERTEK TESTING SERVICES TO STANDARDS: CSA B366.2, ULC S627, UL 1482. MODEL 1100 HAS BEEN TESTED AND LISTED FOR INSTALLATION IN MOBILE HOMES.

EPA 1100, 1100L, 1100C, 1150,
1400, 1400L, 1450 & 1900
FREE STANDING MODELS

EPI 1101, 1402
INSERT MODEL

SAFETY INFORMATION

! WARNING

If the information in these instructions is not followed exactly, a fire or explosion may result causing property damage, personal injury or death. Improper installation, adjustment, alteration, service or maintenance can cause injury or property damage, bodily injury or even death. Please read entire manual before you install and use your fireplace.
This fireplace has not been tested with an unvented gas log set. To reduce risk of fire or injury, do not install an unvented gas log set into the fireplace.

- This fireplace can be very hot when burning.
- Combustible materials such as firewood, wet clothing, etc. placed too close can catch fire.
- Children and pets must be kept from touching the fireplace when it is hot.
- The chimney must be sound and free of cracks. Before installing this unit, contact the local building or fire authority and follow their guidelines.
- Operate only with the door tightly closed.
- Burn wood behind the log retainer directly on the firebricks.
- Do not use an elevated grate or otherwise raise the fire
- At least 14 square inches of outside air must be admitted to the room or directly to the unit through a 4" diameter pipe.
- This fireplace is designed to burn natural wood only. Higher efficiencies and lower emissions generally result when burning air dried seasoned hardwoods, as compared to softwoods or to green or freshly cut hardwoods.
- Do not start a fire with chemicals or fluids such as gasoline, engine oil, etc.
- Do not burn treated wood, coal, charcoal, colored paper, cardboard, solvents or garbage
- Do not let the fireplace become hot enough for any part to glow red.
- **KEEP THE STOVE TOP TEMPERATURE BELOW 700°F (371°C).** Attempts to achieve heat output rates that exceed design specifications can result in steel distortion and damage.

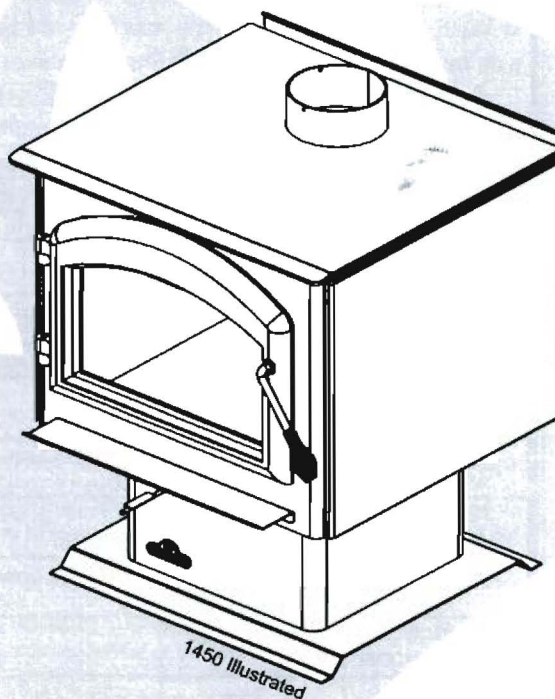

Wolf Steel Ltd., 24 Napoleon Rd., Barrie, ON L4M 4Y8 Canada • (705)721-1212 • fax(705)722-6031
www.napoleonfireplaces.com • ask@napoleon.on.ca

TABLE of CONTENTS

PG 2-4 INTRODUCTION

Warranty
General Information
Care of Plated & Enamelled Parts
Care of Glass

5-6 INSTALLATION

Installing the Legs
Alcove Installation
Stove Installation
Chimney Connection
Adding Chimney Sections
Outside Air
Wall Pass-through

6-7 MOBILE HOME

Venting
Outside Air

7-8 FIREPLACE INSERT

Prior to Installation
Installation into a Masonry Fireplace
Installation into a Factory Built Fireplace

8-9 OPTIONAL BLOWER

Stove Models
Leg Models
Insert Models
1101 Blower Service and Replacement
1402 Blower Service and Replacement
1150 Blower Installation
1150 Features

10-11 FINISHING

Brick Installation
Ornamental Trivet Installation
Door and Handles Installation
Pedestal Trim Installation
Optional Ash Drawer Kit

11-13 OPERATION

Achieving Proper Draft
Fire Extinguishers and Smoke Detectors
Fuel Loading and Burn Cycle
Flash Fire
Extended Fire
Smoking
Ash Removal Procedures

13-14 MAINTENANCE

Creosote Formation and Removal
Runaway or Chimney Fire
Gasket Replacement
Door Removal

14 WOOD PILE MAINTENANCE

15-17 REPLACEMENTS

Ordering Replacement Parts
Replacement Parts
Accessories

PLEASE RETAIN THIS MANUAL FOR FUTURE REFERENCE

Specifications	MODEL 1100, 1100C & 1100L	MODEL 1150	MODEL 1101 (INSERT)	MODEL 1400, 1400L, & 1450	MODEL 1402 (INSERT)	MODEL 1900
WIDTH	25 1/2" (65 cm)	29 3/8" (74.6 cm)	28" (71 cm)	25 1/2" (65 cm)	25 1/2" (65 cm)	25 1/2" (65 cm)
DEPTH	22 1/2" (57 cm)	23 3/16" (58.8 cm)	27" (69 cm)	27" (69 cm)	27" (69 cm)	31 1/2" (80 cm)
DEPTH BEHIND FLASHING			16 1/2 to 21" (42 to 54 cm)		14 1/2" (37 cm)	
FLUE CENTER- LINE TO REAR	6 1/2" (16.51 cm)	6 3/4" (17.1 cm)	11" (27.94 cm)	7 1/2" (19.05 cm)	5 1/2" (13.97 cm)	7 1/2" (19.05 cm)
FLUE CENTER- LINE TO SIDE	12 3/4" (32.39 cm)	14 11/16" (37.39 cm)	14" (35.56 cm)	12 3/4" (32.39 cm)	12 3/4" (32.39 cm)	12 3/4" (32.39 cm)
HEIGHT PEDES- TAL MODEL	33 1/4" (84 cm)	36 1/2" (92.7 cm)	21 1/4" (54 cm)	33 1/4" (84 cm)	21 1/4" (54 cm)	33 1/4" (84 cm)
HEIGHT CAST MODEL	28 1/2" (72 cm)					
HEIGHT LEG MODEL	32" (81 cm)	1 7 ^{ft} (0.05m ³)		32" (81 cm)		
CHAMBER (D.W.H)	13 1/2x18x12" (34x46x31 cm)	13 1/2x18x12" (34x46x31 cm)	13 1/2x18x12" (34x46x31 cm)	18x18x12" (46x46x31 cm)	18x18x12" (46x46x31 cm)	22 1/2x18x12" (57x46x31 cm)
CAPACITY	1.7 ^{ft} (0.05m ³)		1.7 ^{ft} (0.05m ³)	2.25 ^{ft} (0.06m ³)	2.25 ^{ft} (0.06m ³)	3.0 ^{ft} (0.08 m ³)
APPROX. AREA HEATED*	600-1500 ^{ft} (56-139 m ²)	600-1500 ^{ft} (56-139 m ²)	600-1500 ^{ft} (56-139 m ²)	1000-2000 ^{ft} (93-186 m ²)	1000-2000 ^{ft} (93-186 m ²)	1000-3500 ^{ft} (93-325 m ²)
HEAT OUTPUT (HIGH BURN) **	55,000 BTU	55,000 BTU	55,000 BTU	70,000 BTU	70,000 BTU	85,000 BTU
DURATION LOW FIRE*	7 Hours	7 Hours	7 Hours	9 Hours	9 Hours	12 Hours
WEIGHT w/o BRICKS	215 lbs (97.5 kg)	280 lbs (127 kg)	185 lbs (83.9 kg)	250 lbs (113 kg)	250 lbs (113 kg)	285 lbs (129 kg)
WEIGHT OF BRICKS	110 lbs (54.4 kg)	110 lbs (54.4 kg)	110 lbs (54.4 kg)	145 lbs (65 kg)	145 lbs (65 kg)	114 lbs (52 kg)

* FIGURES WILL VARY CONSIDERABLY WITH INDIVIDUAL CONDITIONS.

** WOLF STEEL LTD. ESTIMATED REALISTIC BTU/H WITH HARDWOOD LOGS AND REGULAR REFUELING

NOTE: Changes, other than editorial, are denoted by a vertical line in the margin

NAPOLEON® products are manufactured under the strict Standard of the World Recognized ISO 9001 : 2000 Quality Assurance Certificate.

NAPOLEON® products are designed with superior components and materials, assembled by trained craftsmen who take great pride in their work. The complete fireplace is thoroughly inspected by a qualified technician before packaging to ensure that you, the customer, receives the quality product that you expect from NAPOLEON®.

NAPOLEON® WOOD FIREPLACE PRESIDENT'S LIFETIME LIMITED WARRANTY

The following materials and workmanship in your new NAPOLEON® wood fireplace are warranted against defects for as long as you own the fireplace. This covers: combustion chamber, heat exchanger, ceramic glass (thermal breakage only), gold plated parts against tarnishing, porcelainized enamelled components, aluminum extrusion trims ashdrawer, and cast iron castings.

Electrical (110V) components and wearable parts such as blowers, thermal switch, switches, wiring, firebrick, gasketing, stainless steel baffle retainer, and high temperature paint are covered and NAPOLEON® will provide replacement parts free of charge during the first year of the limited warranty.

Labour related to warranty repair is covered free of charge during the first year. Repair work, however, requires the prior approval of an authorized company official. Labour costs to the account of NAPOLEON® are based on a predetermined rate schedule and any repair work must be done through an authorized NAPOLEON® dealer.

CONDITIONS AND LIMITATIONS

NAPOLEON® warrants its products against manufacturing defects to the original purchaser only – i.e., the individual or legal entity (registered customer) whose name appears on the warranty registration card filed with NAPOLEON® -- provided that the purchase was made through an authorized NAPOLEON® dealer and is subject to the following conditions and limitations:

This factory warranty is non-transferable and may not be extended whatsoever by any of our representatives.

The wood fireplace must be installed by an authorized service technician or contractor. Installation must be done in accordance with the installation instructions included with the product and all local and national building and fire codes.

This limited warranty does not cover damages caused by misuse, lack of maintenance, accident, alterations, abuse or neglect and parts installed from other manufacturers will nullify this warranty.

This limited warranty further does not cover any scratches, dents, corrosion or discolouring caused by excessive heat, abrasive and chemical cleaners nor chipping on porcelain enamel parts, nor any venting components used in the installation of the fireplace.

In the first year only, this warranty extends to the repair or replacement of warranted parts which are defective in material or workmanship provided that the product has been operated in accordance with the operation instructions and under normal conditions.

After the first year, with respect to the President's Limited Lifetime Warranty, NAPOLEON® may, at its discretion, fully discharge all obligations with respect to this warranty by refunding to the original warranted purchaser the wholesale price of any warranted but defective part(s).

After the first year, NAPOLEON® will not be responsible for installation, labour or any other costs or expenses related to the reinstallation of a warranted part, and such expenses are not covered by this warranty.

Notwithstanding any provisions contained in the President's Limited Lifetime Warranty, NAPOLEON'S responsibility under this warranty is defined as above and it shall not in any event extend to any incidental, consequential or indirect damages.

This warranty defines the obligations and liability of NAPOLEON® with respect to the NAPOLEON® wood fireplace and any other warranties expressed or implied with respect to this product, its components or accessories are excluded.

NAPOLEON® neither assumes, nor authorizes any third party to assume, on its behalf, any other liabilities with respect to the sale of this product. NAPOLEON® will not be responsible for: over-firing, downdrafts, spillage caused by environmental conditions such as rooftops, buildings, nearby trees, hills, mountains, inadequate vents or ventilation, excessive venting configurations, insufficient makeup air, or negative air pressures which may or may not be caused by mechanical systems such as exhaust fans, furnaces, clothes dryers, etc.

Any damages to fireplace, combustion chamber, heat exchanger, brass trim or other component due to water, weather damage, long periods of dampness, condensation, damaging chemicals or cleaners will not be the responsibility of NAPOLEON®

The bill of sale or copy will be required together with a serial number and a model number when making any warranty claims from your authorized dealer. The warranty registration card must be returned within fourteen days to register the warranty.

NAPOLEON® reserves the right to have its representative inspect any product or part thereof prior to honouring any warranty claim.

GENERAL INFORMATION

Except for their different depths, models 1100, 1150, 1400, 1900, 1450 and the fireplace inserts 1101, and 1402 are identical and use the same burning principles. They were specifically designed over many months of research to meet the 1990 U.S.A. EPA particulate emission standards and have been extensively tested in Canadian and American laboratories. This system is the most efficient, simple and trouble free we know and works as follows:

Combustion air enters through two holes in the bottom covered by a single draft control. Air from the front hole goes up on either side of the door into a preheating airwash located across the top and then down the window to feed the fire and also to ensure that the glass remains clean. Air from this hole also feeds directly into the combustion chamber at hearth level. Secondary air from the rear hole travels up the back in the secondary air housing to the manifold located at the top and shoots out laterally to oxidize the gases below the smoke exit.

The combustion chamber is lined with high temperature fire-brick on 2 sides, the back and across the bottom, with a layer of fibre baffles at the top to maintain a high temperature in the combustion chamber so that gases mixing with the preheated air from the secondary air manifold tube are easily ignited and burned. The stove sides and back are shielded to direct the heat upwards and forwards into the room.

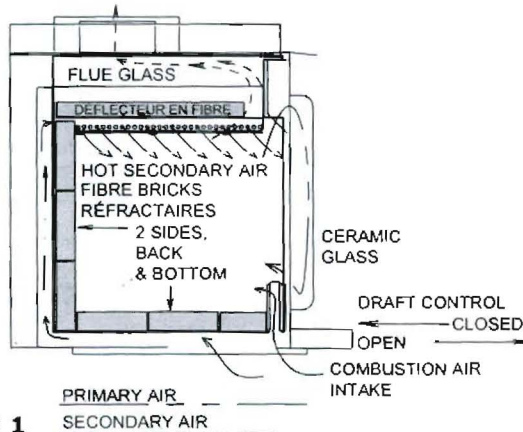

FIGURE 1

Be sure to provide sufficient combustion air. There are many other appliances in your home competing for air such as: a kitchen range hood, forced air heating devices or a bathroom exhaust fan.

Do not connect this unit to a chimney flue serving another appliance.

Expansion / contraction noises during heating up and cooling down cycles are normal and to be expected.

After extended periods of non-operation such as following a vacation or a warm weather season, the fireplace may emit a slight odour for a few hours. This is caused by dust particles on the firebox burning off. Open a window to sufficiently ventilate the room.

CALIFORNIA PROP 65 WARNING:

Use of this product may produce smoke which contains chemicals known to the State of California to cause cancer, birth defects, or other reproductive harm.

PEDESTAL MODELS ONLY

If the outside air feature of the stove is utilized, you should never experience a shortage of combustion air. If you choose not to utilize outside air and experience draft or smoking problems, you may need to open a door or window.

WARNING: Burning your unit with the ash dump door open or ajar creates a fire hazard that may result in discoloration to the gold plated door, internal damage to the stove or a house and/or chimney fire.

To ensure that the ash dump door is tightly closed, allow the door to snap shut dislodging anything (ashes or pieces of coal) that may be stuck in the opening.

LEG MODELS ONLY

If you experience smoking problems, you may need to open a door, a window or otherwise provide some method of supplying combustion air to the unit.

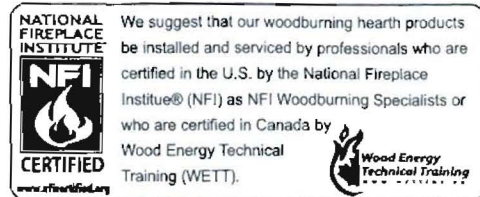

CARE OF ALL PLATED AND ENAMELED PARTS

Do not use abrasive cleaners to clean these parts. Buff lightly with a clean dry cloth.

Prolonged high temperature burning with the door ajar may cause a permanent rainbowing effect on the lower edge of a gold plated door.

Porcelain enamel components must be handled with care. The baked-on finish is "glass". If struck, it will chip. Touch-up paint is available through your Napoleon dealer.

CARE OF GLASS

If the glass is not kept clean permanent discoloration and / or blemishes may result. Normally a hot fire will clean the glass. The most common reasons for dirty glass include; not using sufficient fuel to get the stove thoroughly hot, using green or wet wood, closing the draft so far that there is insufficient air for complete combustion. If it is necessary to clean the glass, use a soft cloth with a nonabrasive cleaner.

DO NOT CLEAN GLASS WHEN HOT!

The glass is very strong but do not let burning fuel rest against it and always close the door gently. If the glass should ever crack while the fire is burning, do not open the door until the fire is out and do not operate the stove again until the glass has been replaced with a new 5mm thick plate of ceramic glass, available from your Napoleon / Wolf Steel Ltd. dealer.

DO NOT SUBSTITUTE MATERIALS.

TO REMOVE THE GLASS: When the unit is cool, open the door and remove the screws and brackets holding the glass in place. Remove all broken glass. Wrap the edges of the new glass with a U-shaped strip of fiberglass gasket, covering 1/4" on each side. Place the glass with the fiberglass gasket in position and replace the brackets and screws. When finished, you should be able to move the glass slightly, horizontally and vertically.

STOVE INSTALLATION

INSTALLING THE LEGS

To avoid being damaged during shipping, the stove has been bolted to the pallet and must be unbolted before the stove can be installed.

1. Remove the 4 nuts and washers from the underside of the pallet.

2. Lift the stove up and away from the pallet to clear the threaded studs sticking through the pallet. Place the stove on its back onto a protective surface such as a carpet or blanket to avoid scratches during leg installation.

FIGURE 2A

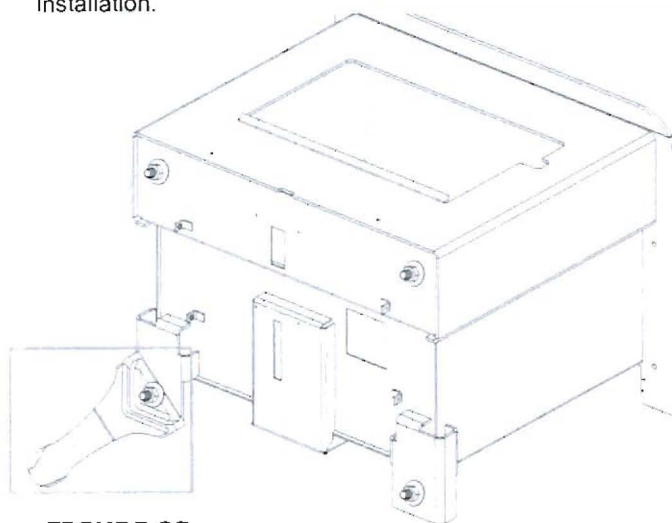
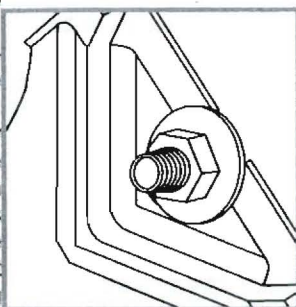

FIGURE 2B

3. Remove the four additional nuts from each of the four studs.

4. Use four of the nuts and washers removed above to install the legs as illustrated in FIGURES 2a & 2b.

5. Lift the stove up and gently set down on all four legs. Do not pivot unit up on its legs, as this could result in damage to the legs.

ALCOVE INSTALLATION

Model 1100 only may be installed, using a listed double wall connector, such as **Security DL6** in Canada, the **Simpson Duravent Plus DVL** in the USA or an equivalent double wall connector, into an alcove having a depth of no more than 4 feet and a height of at least 7 feet. The minimum clearances are as shown in FIGURE 3.

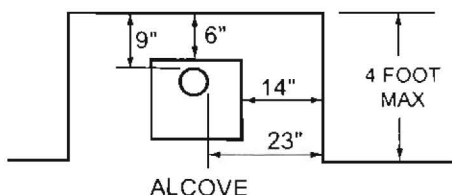

FIGURE 3

STOVE INSTALLATION

If the stove is to be installed on a combustible floor, it must be placed on an approved non-combustible hearth pad, that extends 8" (200mm) beyond the stove sides and back, and 18" (455mm) to the front. It must be installed with a minimum height of 7' between the stove base and the ceiling.

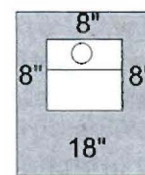

FIGURE 4A

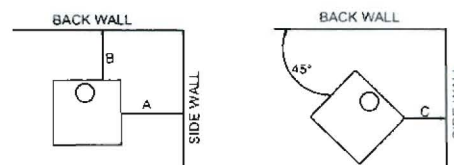

FIGURE 4B

SINGLE WALL CHIMNEY CONNECTOR*

	1100/1100L/1150	1400/1400L	1900
A	12" (305 mm)	12" (305 mm)	22" (560 mm)
B	10" (254 mm)	12" (305 mm)	12" (305 mm)
C	6" (152 mm)	6" (152 mm)	8" (205 mm)

* CLEARANCES CAN BE REDUCED WITH SHIELDING ACCEPTABLE TO LOCAL AUTHORITIES. REDUCED INSTALLATION MUST COMPLY WITH NFPA 211 or CAN/CSA-B365

DOUBLE WALL CHIMNEY CONNECTOR

	1100/1100L	1400/1400L	1900
A	10" (254 mm)	10" (254 mm)	22" (560 mm)
B	6" (152 mm)	6" (152 mm)	12" (305 mm)
C	2" (50 mm)	4" (102 mm)	8" (205 mm)

NOTE: CLEARANCES ARE UNABLE TO BE REDUCED FOR THE 1150 BY USING DOUBLE WALL PIPE.

CHIMNEY CONNECTION

A 6" diameter single wall stove pipe, used to connect the stove to the chimney, must be installed with the crimped end toward the stove. This will ensure that the moisture which condenses from the burning wood will flow back into the fire chamber. Each joint in the stove pipe must be secured with at least three sheet metal screws.

This room heater must be connected to:

1) A chimney complying with the requirements for Type HT chimneys in the Standard for Chimneys, Factory-Built, Residential Type and Building Heating Appliance UL 103, or
2) A code-approved masonry chimney with a flue liner.
Vent the stove into a masonry chimney or an approved, insulated solid-fuel stainless-steel chimney with as short and straight a length of six-inch (150mm) diameter smoke pipe as possible. Connection to a masonry chimney must be by a metal or masonry thimble cemented in place.

An insulated stainless steel chimney must be supported at the ceiling or roof and its installation must comply with its manufacturer's instructions.

THE TOTAL HORIZONTAL VENT LENGTH SHOULD NOT EXCEED 40% OF THE CHIMNEY HEIGHT ABOVE THE STOVE.

All horizontal smoke pipe must slope slightly upwards a minimum of 1/4" per foot (6mm/0.3m) and all connections must be tight and secured by three sheet metal screws equally spaced.

An uninsulated smoke pipe shall not pass through an attic, roof space, closet or similar concealed space, or through a floor, ceiling, wall or partition, or any combustible construction.

DO NOT USE ANY MAKESHIFT MATERIALS DURING INSTALLATION.

1. Move the stove into position with the flue centered, mid-point between two joists to prevent having to cut them. Use a plumb bob to line up the centre.
2. Cut and frame an opening in the roof to provide a 2" clearance between the outside of the chimney and any combustible material.

DO NOT FILL THIS SPACE WITH ANY TYPE OF MATERIAL.

Nail headers between the joist for extra support. Firestop spacers must be placed on the bottom of each framed opening in any floor or ceiling that the chimney passes through.

3. Hold a plumb bob from the underside of the roof to determine where the opening in the roof should be. Cut and frame the roof opening to maintain proper 2" clearances.

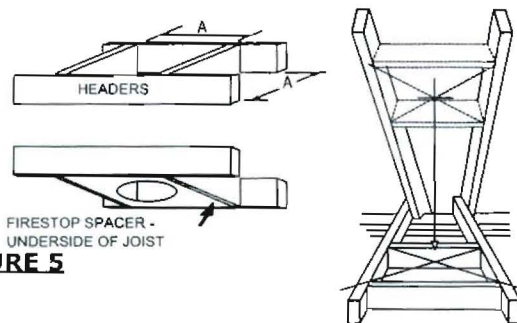

FIGURE 5

ADDING CHIMNEY SECTIONS

Add chimney sections, according to the manufacturer's installation instructions, securely, to the required height. The chimney must extend, at least, 3 feet above its point of contact with the roof and at least 2 feet higher than any wall, roof or building within 10 feet. **FIGURE 6.**

If your chimney system is enclosed within the attic area, a rafter radiation shield is required

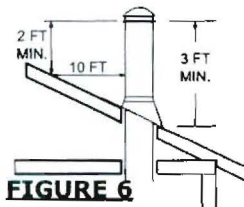
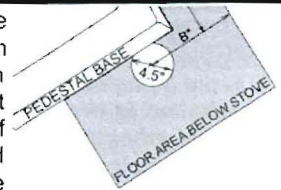

FIGURE 6

PEDESTAL MODELS OUTSIDE AIR

If possible connect the air intake at the pedestal's back or bottom to the outside with a 4 inch (100mm) diameter fresh air kit available at your Napoleon/Wolf Steel Ltd. dealer. Follow detailed instructions under "Mobile Home Outside Air".



	A (in.)	B(in.)
1100	8 5/8"	9 3/4"
1400	11 1/8"	9 3/4"
1900	14 7/8"	9 3/4"

FIGURE 7

WALL PASS-THROUGH

If possible, design the installation so that the connector does not pass through a combustible wall. If during your installation you must pass through a combustible wall, check with your building inspector before you begin. Also check with the chimney connector manufacturer for any specific requirements.

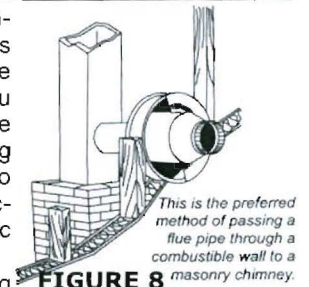

FIGURE 8

Consult with your dealer regarding special connection components available for use for wall pass-throughs.

Use only parts that have been tested and listed for use in a wall pass-through.

MOBILE HOME

PEDESTAL MODEL 1100 IS APPROVED FOR INSTALLATION IN MOBILE HOMES IN BOTH CANADA AND THE UNITED STATES.

1150 IS NOT APPROVED FOR MOBILE HOMES.

PEDESTAL MODEL 1400 IS APPROVED FOR INSTALLATION IN MOBILE HOMES IN THE UNITED STATES ONLY.

WARNING: DO NOT INSTALL IN SLEEPING ROOM.

CAUTION: THE STRUCTURAL INTEGRITY OF THE MOBILE HOME FLOOR, WALL AND CEILING/ROOF MUST BE MAINTAINED.

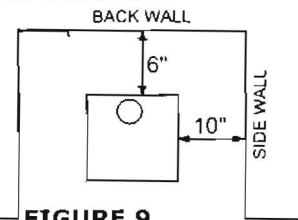

FIGURE 9

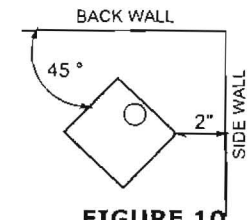

FIGURE 10

The pedestal base must be firmly bolted to the floor with 1/4 inch lag bolts. Minimum clearances to combustibles are as shown in **FIGURE 9.**

VENTING

Connect the stove to a chimney system using a listed double wall connector. Use a chimney system listed to ULC S629 in Canada or UL103HT in the U.S.A.

The chimney must be installed in accordance with the manufacturer's instructions. Use only specified components with no substitutions. The chimney and pipe must extend at least 8 feet above the stove and 3 feet above the highest point of the roof. Install a rain cap at the top which will not impede the smoke exhaust. The chimney must be supported at the ceiling or roof so that its weight does not rest on the stove.

FIGURE 11

It must be installed between ceiling joists, with radiation shield and roof flashing, so that the structural strength, insulation and waterproof qualities of the home are not lessened. Seal with silicone to maintain a vapour barrier at the chimney and outside air pipe penetrations.

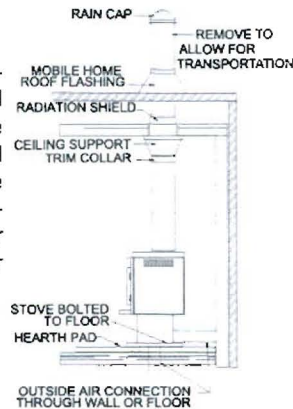

OUTSIDE AIR

Connection from the stove's air intake to the outside is mandatory in mobile homes only, either through a hole in the wall to line up with the knockout in the pedestal back, or through a hole in the floor to line up with the hole in the pedestal base. Use a fresh air kit. Secure the 4 inch diameter aluminum liner by flaring the end once it is inserted through the 4-1/2 inch diameter hole in either the back or base of the pedestal. If the air intake is through the floor, the hole in the pedestal back must be covered with sheet metal to avoid cold air spillage into the room. A cover plate is available from your Wolf Steel Ltd. dealer. Avoid cutting away floor joists, wall studs, electrical wires or plumbing. Seal around the outside pipe with insulation to prevent drafts.

Attach the rear knockout plate (located inside the ash pan for shipping purposes).

If room air starvation occurs because the fresh air intake is blocked with ice, leaves, etc., or because the stove door was left open, or due to a strong exhaust fan operating etc., dangerous fumes and smoke from the operating stove could be drawn into the room.

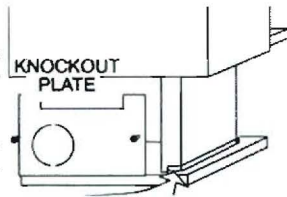

FIREPLACE INSERT

Your EPI 1101 and 1402 insert firebox is the exact duplication of the clean-burning technology found in all Napoleon EPA certified freestanding stoves and in particular that of the EPA 1100 and 1400. External modifications have been made to allow its installation as a "functional fireplace insert" with a heat circulating blower system and a means of enclosing the solid fuel burning fireplace cavity for greater heating efficiency. The EPI 1101 insert must be installed into a solid fuel burning fireplace that is at least 16 1/2 to 21 inches deep, 28 1/2 inches wide and 21 1/2 inches high with an approved lined chimney at least 15 feet high (4.6m).

Your EPI 1402 fireplace insert must be installed only into a solid fuel burning fireplace that is at least 14 inches deep 26 inches wide and 22 inches high with an approved lined chimney at least 15 feet high (4.6m). *This minimum recess can only be achieved if the opening height is sufficient enough to allow the connector to fit under the noncombustible facing.* The fireplace and chimney must be constructed in accordance with all national and local building code standards.

HINT FOR INSTALLING PORCELAIN ENAMEL INSERTS:

Ensure the base of the porcelain side panels are protected from rubbing against the hearth when sliding your insert into the masonry fireplace.

PRIOR TO INSTALLATION

Clean all ashes out of the inside of the fireplace. Make sure that the chimney and fireplace are free of cracks, loose mortar, creosote deposits, blockage or other signs of deterioration. If necessary, have any repair work done by a qualified professional before installing the insert.

Do **NOT** remove bricks or mortar from the fireplace. In case of an outside air inlet or ash dump, fill with fiberglass insulation. Adhere to minimum clearances as shown in **FIGURE 12**.

Do **NOT** place any combustible materials (furniture, firewood, etc.) within 48 inches in front or 36 inches at the side of the insert.

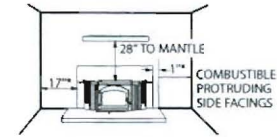

Combustible material must **FIGURE 12** not protrude more than 1" to the side of the insert or between the mantle and the top of the insert.

INSTALLATION INTO A MASONRY FIREPLACE

1. Remove the fireplace damper or fasten it permanently open.

* We recommend the following method of sealing off the damper area around the liner.

2. *Measure the throat of the fireplace and mark this shape on a piece of 24 gauge sheet metal (flue cover); cut a six-inch (6.75") hole to lie directly below the fireplace flue opening. Allow two inches of material for a flange on all sides and cut to these measurements. Bend down the flanges. If you have never done this before, it might be a good idea to make a cardboard pattern and test it first. Fasten this flue cover in position as high as possible with two masonry screws per side through the flanges into the fireplace **FIGURE 13**.

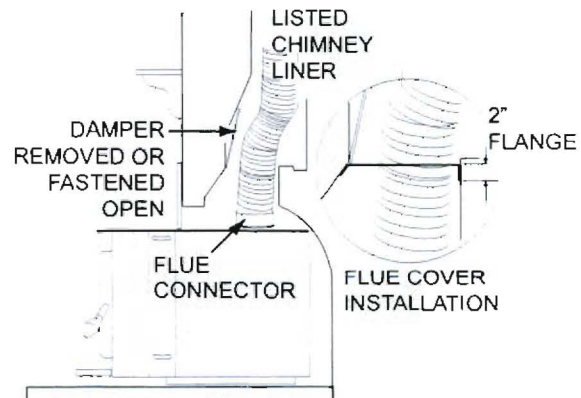
**FIGURE 13****MODEL 1402 Illustrated**

In Canada: Install a listed 6 inch diameter flexible stainless steel liner from the top of the chimney to the insert flue collar. Attach a stainless steel liner connector or elbow to the liner and insert onto the flue collar. Fasten with three screws. Secure the top of the liner to the chimney cap using a liner support and chimney flashing. Cap the top of the chimney liner assembly using an approved rain cap.

In the United States: While it is not required, it is recommended that a chimney liner be installed that is continuous from the insert to the top of the chimney, particularly when the insert is installed in a basement. For this type of connection, use the "In Canada" installation instructions above.

In the United States, continued:

If a continuous liner is not installed, a "direct flue connection" must be made. The direct flue connection requires a non-combustible connector that extends from the insert into the chimney flue liner and also that the installed flue cover be sealed below the entry point of the connector to prevent dilution of combustion products in the chimney flue with air from inside the house. Cap the top of the chimney using an approved rain cap.

1402 INSERT MODEL

An optional low clearance flue connector is available to facilitate hook up into a tight fitting fireplace. Consult your local dealer for details.

The following installation requirements must be observed when installing solid fuel burning inserts into factory built fireplaces.

INSTALLATION INTO A FACTORY BUILT FIREPLACE

1. The factory built fireplace must be listed per UL 127 or ULC S610.
2. Clearances to any combustible material surrounding this insert as identified in Figure 10 must be followed. These clearance requirements supersede any pre-existing facing material clearances listed for the factory built fireplace.
3. Installation must include a full height listed chimney liner meeting HT requirements (2100°F) per 1777 (U.S.) or ULC S635 (Canada). The liner must be securely attached to the insert flue collar and the chimney top.
4. Means must be provided to prevent room air passage to the chimney cavity of the fireplace. This may be accomplished by sealing the damper area around the chimney liner, or sealing the fireplace front.
5. The air flow within and around the fireplace shall not be altered by the installation of the insert (i.e. no louvres or cooling air inlet or outlet ports are blocked), unless specifically tested as such for each factory built fireplace manufacturer and model line. (Note - using a louvred face plate (surround) complies with this requirement)
6. Alteration of the fireplace in any manner is not permitted with the following exceptions;
 - a. external trim pieces which do not affect the operation of the fireplace may be removed providing they can be stored on or within the fireplace for reassembly if the insert is removed.
 - b. the chimney damper may be removed to install the chimney liner.
7. Circulating air chambers (i.e. in a steel fireplace liner or metal heat circulator) shall not be blocked.
8. Means must be provided for removal of the insert to clean the chimney flue.
9. Inserts that project in front of the fireplace must be supplied with appropriate support means.
10. A permanent metal warning label must be attached to the back of the fireplace stating that the fireplace must be restored to its original condition for safe use without the insert.

OPTIONAL BLOWER

Drywall dust will penetrate into the blower bearings, causing irreparable damage. Care must be taken to prevent drywall dust from coming into contact with the blower or its compartment. Any damage resulting from this condition is not covered by the warranty policy.

Use of the blower increases the output of heat.

STOVE MODELS

Provisions have been made on the stove to install an optional blower kit (EP62-1) that comes complete with a variable speed switch to turn the blower on and off, as well as adjusting the blower speed. An optional thermostatic sensor control kit, EP36, to thermally activate the blower is also available.

LEG MODELS ONLY

NOTE: if the optional blower (EP62-1) is installed, the blower guard (W320-0011) must be installed. This guard is available from your Napoleon dealer.



Attach the mounting bracket to the blower assembly. Then attach the mounting bracket to the back of your stove, push on the variable speed knob and plug into any grounded electrical outlet.

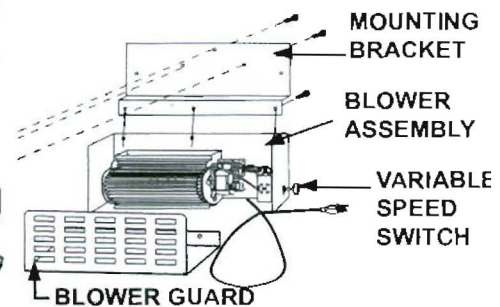

FIGURE 14

INSERT MODELS

The 1402 inserts comes equipped with two blowers, while the 1101 has one blower. These blowers are thermally activated. Depending on the intensity of the fire, the blowers will start 15-30 minutes after lighting. The heat sensor for the 1402 is located on the right hand side of the unit and the 1101 has a heat sensor located at the back on the blower access door. When first starting the fire, the sensor may be impeded by a large log or an unevenly burning fire, causing the blowers to cycle on and off. To control this, either build your fire up evenly or turn down the blowers until the right side of the firebox is hot.

1101 BLOWER SERVICE OR REPLACEMENT

1. Turn off all electrical power to the insert. Remove the glass door and set aside in a safe place.
2. Remove the top right side bricks from inside the firebox, 4-#7's and 2-#2's. Then remove the rest of the side and back bricks from the right side of the 1101 insert. It is not necessary to remove the bottom bricks.

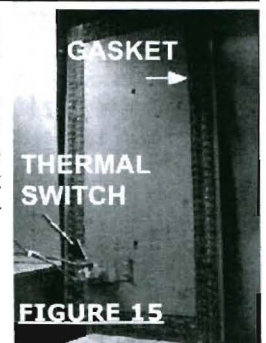

FIGURE 15

3. The access panel can be removed by taking out the 8 #10 self tapping screws. A 5/16" nut driver will be required to complete this job. Unplug wires from the thermal switch on the panel. See **FIGURE 15**.

4. Remove the securing wingnut from the blower mounting bracket, slide the bracket to the right and rotate the left side of the assembly out of the cavity to clear the blower motor. Disconnect the two wires from the blower motor. Remove the ground wire from the blower mounting bracket, then the assembly can be taken out of the rear cavity through the access door opening.

5. Remove the 3 screws that hold the blower to the mounting bracket. Service or replace the blower as required.

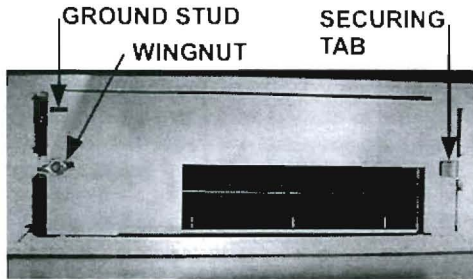
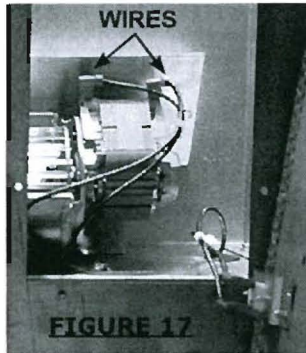

FIGURE 16

6. Reinstall the blower assembly making sure the blower bracket is seated under the securing tab. **FIGURE 16**. Reattach the wire connectors. **FIGURE 17**



7. Replace the gasket on the access door. To replace the access panel, reverse Step 3.

8. Replace the bricks into the firebox. Reinstall the door.

1402 BLOWER SERVICE OR REPLACEMENT

1. Turn off all electrical power to the insert. Remove the glass door and set aside in a safe place.

2. Remove the two screws from the outer edge of the side panel(s).

3. Push the side panel toward the door and pull away from the insert, releasing the panel from the keyed slot.

4. Service or replace the blower(s) as required.

5. Re-install the side panel(s) by reversing the procedure.

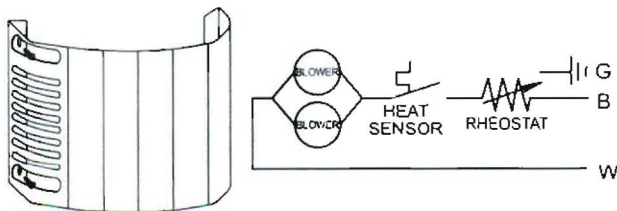

FIGURE 18

1150 BLOWER INSTALLATION

1. Remove the knock-out from the back of the fireplace.

2. Install the blower and housing as shown using the 4 screws supplied.

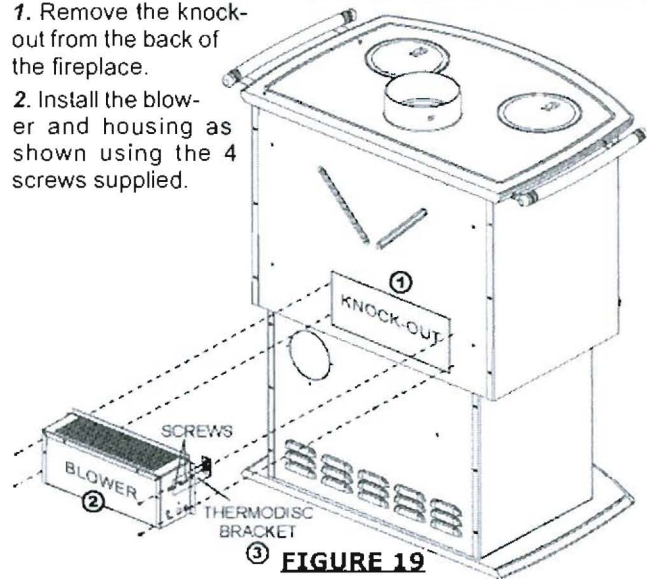
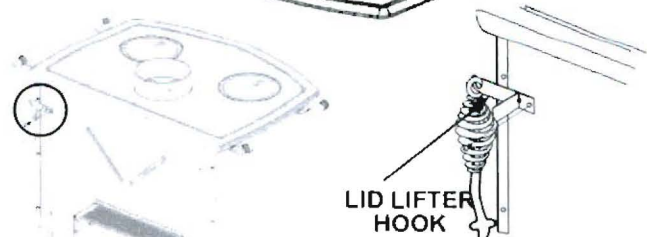
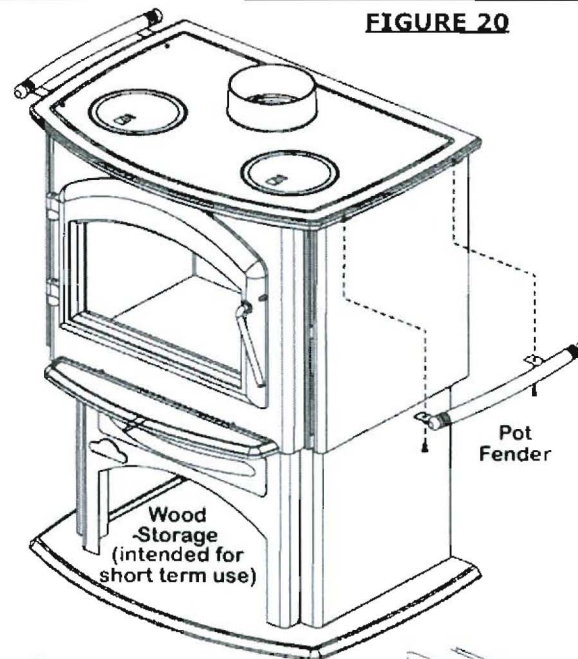

FIGURE 19

3. Loosen the thermodisc bracket (2 screws) and slide the bracket forward until the thermodisc is touching the rear firebox and secure.

1150 FEATURES

FIGURE 20



LID LIFTER HOOK

Remove the screw, as illustrated, from the preferred side of the stove rear. Secure the lid lifter hook, as illustrated, facing out to the side, or bend it towards the back.

FINISHING

SIZES		1100/1100C/ 1100L/1150	1101	1400/1400L	1402/1450	1900
#1. 1-1/4" x 4"-1/2" x 9"	BACK	4-#1	4-#1	4-#1	4-#1	4-#7*
#2. 1-1/4" x 3" x 9"		2-#4	2-#4	2-#4	2-#4	2-#2
#3. 1-1/4" x 4-1/2" x 4-1/2"	SIDES	8-#1	8-#1	12-#1	12-#1	12-#7*
#4. 1-1/4" x 4-1/2" x 9"		2-#3	2-#3			2-#3
#5. 1-1/4" x 2-1/2" x 4-1/2"						2-#4
#6. 1-1/4" x 1-1/2" x 4-1/2"						(notched)
#7. 1-1/4" x 4-1/2" x 9"	TOP	2-#10	2-#10	2-#11	2-#11	2-#12
* (light weight)						2-#13
#8. 1-1/4" x 2-1/4" x 9"	FLOOR	3-#1	4-#1	5-#1	6-#1	7-#7*
#9. 1-1/4" x 2-1/4" x 6-1/8"		2-#2	2-#2	2-#2	2-#2	2-#2
#10. Fibre baffle - 9" x 1" x 12"		1-#5		1-#5		1-#5
#11. Fibre baffle - 9" x 1" x 16 1/2"		1-#6		1-#6		1-#6
#12. Fibre baffle - 9" x 1" x 9 3/4"	FRONT	2-#2	2-#2	2-#2	2-#2	2-#2
#13. Fibre baffle - 9" x 1" x 9 3/4"		1-#8	1-#8	1-#8	1-#8	1-#8
		1-#9	1-#9	1-#9	1-#9	1-#9

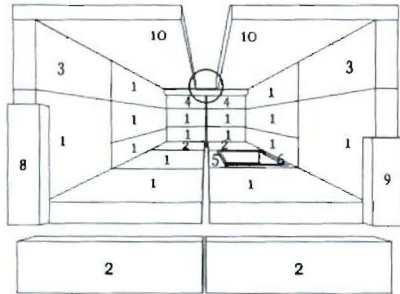

**MODEL 1100/1100C/1100L/1150
- FIGURE 21**

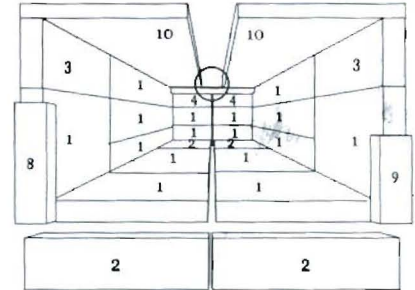

MODEL 1101 - FIGURE 22

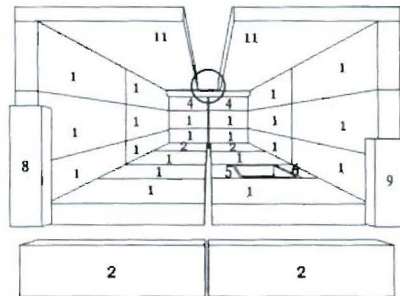

**MODEL 1400 / 1400L -
FIGURE 23**

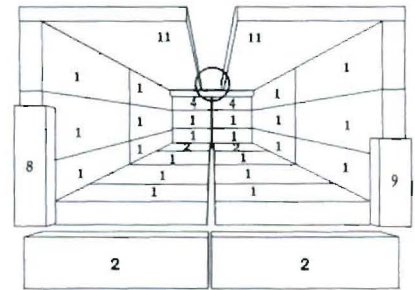

MODEL 1402 - FIGURE 24

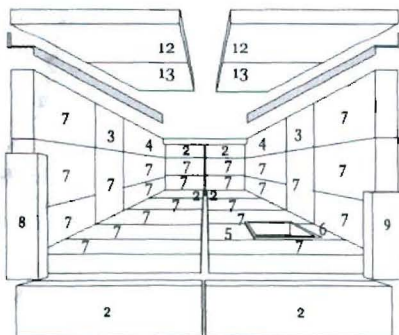

MODEL 1900 - FIGURE 25

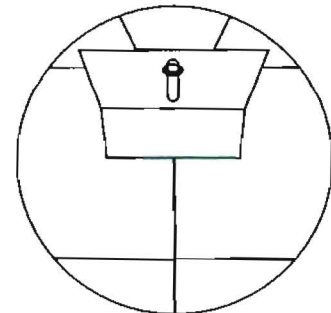
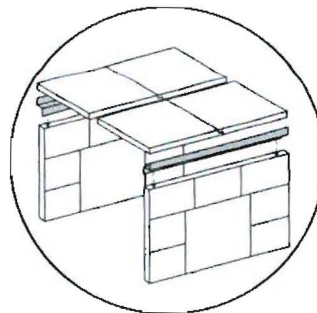

**AREA CIRCLED ON EACH FIGURE INDICATES
THE BRICK RETAINER DETAIL**

BRICK RETAINER DETAIL - TYPICAL

BRICKS AND BAFFLES INSTALLATION

With stove and chimney installation completed, move the bricks into place by working as illustrated for your unit on page 10.

1. Install two or three courses of brick on both sides of the unit. Install two courses on the back wall. Install the final course of bricks on the back wall. These bricks are held in place by a brick retainer. Before installing the bricks, loosen the screw holding the retainer and ensure that it has been moved forward. Insert the final two bricks behind the retainer and while still holding the bricks in place, slide the retainer snugly into place. Retighten the screw.

2. 1900 only:

Place the stainless steel support onto the top row of the bricks as illustrated on page 10.

Pivot the 2 piece baffle up and onto the support, then slide them over and onto the flange of the manifold. Ensure that the overlaps are interlocked to close the gap. Push the baffles to the rear of the firebox. Repeat for the opposite side.

3. Carefully pivot fibre baffle up onto the top of the side brick. Slide it over onto the flange of the manifold.

Ensure that the top baffles are pushed all the way to the rear of the firebox, leaving a minimum of a 1 inch gap along the front. This will allow the flue gases to escape the firebox.

4. Install the bottom bricks, working from the back of the unit.

5. Install the 2 bricks along the front.

NOTE: DO NOT OPERATE IF BAFFLE AND MANIFOLD SHEILD ARE NOT IN POSITION

ORNAMENTAL TRIVET INSTALLATION

Insert the ornamental trivet into the space on the stove top.



FIGURE 26

DOOR AND HANDLE INSTALLATION

Hang the door using the hinge pins supplied. Twist the large wire handle over the end of the handle rod.



Twist the smaller wire handle over the end of the air damper rod below the door. Install ash pan pull handle using screws and washers.

See **FIGURE 26**.

FIGURE 27

PEDESTAL TRIM INSTALLATION

Ensure that the pedestal surfaces are clean and dry; peel the protective backing from the trim adhesive. Insert one end of the brass trim into one of the slots located in the pedestal and pressing firmly, proceed around to the other slot. Cut trim to size. Attach the rear knockout plate (located inside the ash pan for shipping purposes).

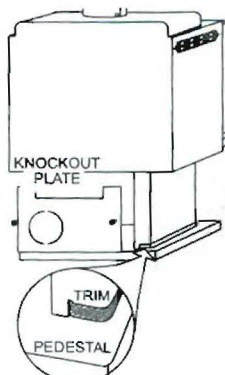

FIGURE 28

OPTIONAL ASH DRAWER KIT

Models 1100L / 1400L Only: Provisions have been made on the stove to install an optional ash drawer kit. The EPAD-KT kit allows for convenient removal of excess ash. This kit can be purchased through your Napoleon Dealer.

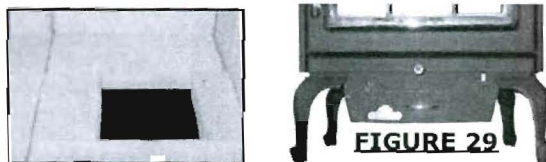

FIGURE 29

OPERATION

CAUTION: Never use gasoline, gasoline-type lantern fuel, kerosene, charcoal lighter fluid, or similar liquids to start or 'freshen up' a fire in this heater. Keep all such liquids well away from the heater while it is in use.

Objects placed in front of the fireplace should be kept a minimum of 48" from the front face.

Your Napoleon EPA listed product is a Hi-Tech unit, designed with the most advanced technology. The unit is extremely airtight. It has an exclusive direct outside air supply (optional kit), a safety feature designed to prevent spillage, and to keep your house free of carbon monoxide, in case of a downdrafting chimney or an internal negative pressure.

The first fire(s) in your unit will be difficult to get going and keep going with little amount of heat being generated. This is a result of the moisture being driven out of the fire brick. Allow 30 to 40 hours of hot fires (temperatures in excess of 500°F - 600°F) before your unit will perform normally. During the break-in period (the first 2 or 3 fires) create only small, hot fires using kindling; this will allow the firebrick to cure. Do not be alarmed if small hairline cracks develop in the firebrick. This is a normal occurrence and does not pose a safety hazard. The paint may also smell a little for the first few fires as it cures and you may wish to open a door or window to alleviate the smell.

To start, a brisk fire is required. Place loosely crumpled paper on the floor of the stove and cover with dry kindling. Open the draft control fully by pulling the lever forward. Light the paper and leave the door slightly ajar (one inch) until all kindling is burning. To maintain a brisk fire, a hot coal bed must be established and maintained.

Slowly add larger wood (2x4 size pieces). Lay the pieces lengthwise from side to side in the hot coal bed with a shallow trench between, so that the primary air can flow directly into this trench and ignite the fuel above. When the fire seems to be at its peak, medium sized logs may be added. Once these logs have caught fire, carefully close the door. (Closing the door too quickly after refueling will reduce the firebox temperature and result in an unsatisfactory burn.) Remember it is more efficient to burn medium sized wood, briskly, and refuel frequently than to load the fireplace with large logs that result in a smouldering, inefficient fire and dirty glass.

As soon as the door is closed, you will observe a change in the flame pattern. The flames will get smaller and lazier because less oxygen is getting into the combustion chamber. The flames, however, are more efficient. The flames will remain lazy but become larger again as soon as the firebricks have been heated thoroughly and the chimney becomes heated and provides a good draft. At this point, the roaring fire that you see when the door is opened is wastefully drawing heated room air up the chimney – certainly not desirable. Always operate with the door fully closed once the medium sized logs have caught fire.

You can now add larger pieces of wood and operate the stove normally. Once the stove/insert is entirely hot, it will burn very efficiently with little smoke from the chimney. There will be a bed of orange coals in the firebox and secondary flames flickering just below the top firebrick. You can safely fill the firebox with wood to the top of the door and will get best burns if you keep the stove pipe temperatures between 250 degrees Fahrenheit (120 degrees Celsius) and 450 degrees Fahrenheit (270 degrees Celsius). A surface thermometer will help regulate this.

Without a stove thermometer, you are working blindly and have no idea of how the stove is operating! A stove thermometer offers a guide to performance.

Can't get the fire going? Use more kindling and paper. Assuming the chimney and vent are sized correctly and there is sufficient combustion air, the lack of sufficiently dry quantities of small kindling is the problem. Thumb size is a good gauge for small kindling diameter.

Can't get heat out of the unit? One of two things may have happened. The stove/insert door may have been closed prematurely and the unit itself has not reached optimum temperature. Reopen the door and/or draft control to re-establish a brisk fire. The other problem may have been wet wood. The typical symptom is sizzling wood and moisture being driven from the wood.

ACHIEVING PROPER DRAFT

Draft is the force which moves air from the firebox up through the chimney. The amount of draft in your chimney depends on the length and diameter of chimney, local geography, nearby obstructions and other factors. Adjusting

the draft control regulates the temperature. The draft can be adjusted from a low burn rate with the handle in fully, to a fast burn rate with the handle fully out.

Inadequate draft may cause back-puffing into the room through the stove/insert and chimney connector points and may cause plugging of the chimney. Too much draft may cause an excessive temperature in the stove, glowing red stove parts or chimney connectors or an uncontrollable burn which can lead to a chimney fire or permanent damage to the unit. Do not operate your stove/insert for longer than 30 minutes with the draft control on "HIGH" (fully open).

* NOTE: 1100C/1150 and optional EPA Leg Models ash pans are not equipped with a cover or rear folding handle. Ash pan not available for model 1450.

FIGURE 31

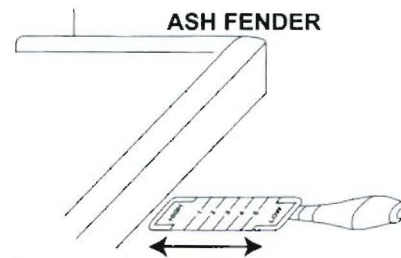
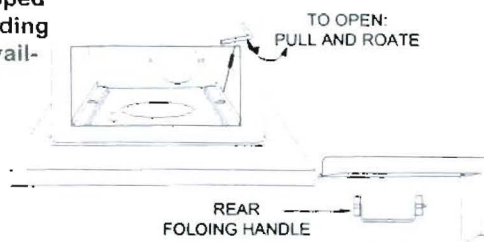

FIGURE 30



FIRE EXTINGUISHERS / SMOKE DETECTORS

All homes with a solid fuel burning fireplace should have at least one fire extinguisher in a central location known to all, and at least one smoke detector in the room containing the fireplace. If it sounds an alarm, correct the cause but do not deactivate or relocate the smoke detector.

FUEL LOADING AND BURN CYCLE

When loading the stove, ensure that the two upper fibre baffles are not lifted up and off their ledge.

For maximum efficiency, when the stove is thoroughly hot, load it fully to the top of the door opening and burn at a medium low setting. Maximum heat for minimum fuel (optimum burn) occurs when the stove top temperature beneath the trivet is between 500°F (260°C) and 600°F (315°C). The bricks will be nearly all white and the glass mostly clear. The whiteness of the bricks and the cleanness of the glass are good indicators of your operating efficiency. Not enough heat is produced when only one or two pieces of wood are burned or the wood may not burn completely. A minimum of three pieces are needed to encase a bed of coals that sustains the fire.

Loosely stacked wood burns quicker than a tightly packed load. Wood burns in cycles rather than giving a steady output of heat. It is best to plan these cycles around your household routine so that only enough coals are left to start the next load. In the evening, load your stove, at least, a half-hour before bed to ensure a good fire, hot enough to close the draft control for an overnight burn. Burn only dry seasoned wood.

It produces more heat and less soot or creosote. Do not burn ocean beach wood. Its salt content can produce a metal eating acid. When refueling open the door slowly to prevent smoke spillage. Use a pair of long gloves (barbecue gloves) when feeding the fire. Because these stoves burn at the front, they are clean and efficient, but they are also very hot and gloves are useful. Keep a small steel shovel nearby to use as a poker and to remove ashes. Do not store the wood within 3 feet (1m) of the stove.

FLASH FIRE

A flash fire is a small fire burned quickly when you don't need much heat. After your kindling has "caught", load at least 3 pieces of wood, stacked loosely. Burn with the draft control fully open or closed only slightly.

EXTENDED FIRE

Load your larger pieces of wood compactly, packed close enough to prevent the flames from penetrating it completely. After approximately 30 minutes, depending on the size of the load, close the draft control completely making sure that the fire is not extinguished.

DO NOT OVERFIRE THE STOVE!

Overfiring can occur by:

- burning large amounts of smaller wood pieces such as furniture scraps, skids or treated wood;
- vigorously burning large loads of wood with the draft control on "HIGH" (fully open) for long periods of time (one or two hours).

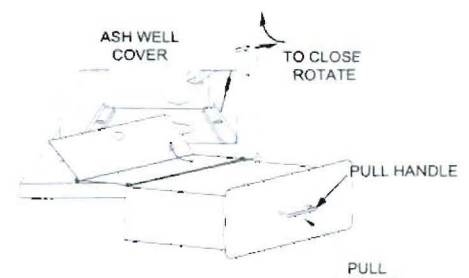

SMOKING

A properly installed Napoleon unit should not smoke. If yours does, check the following: Has the chimney had time to get hot? Is the smoke passage blocked anywhere in the stove, chimney connector or chimney? Is the room too airtight and the air intake not connected to the outside? Try with a window partly open. Is the smoke flow impeded by too long a horizontal pipe or too many bends? Is it a weak draft perhaps caused by a leaky chimney, a cold outside chimney, too large a diameter of a chimney, too short a chimney, or a chimney too close to trees or a higher roof? Has a direct flue connection been used rather than a chimney liner continuous from cap to fireplace flue collar.

ASH REMOVAL PROCEDURES

Allow the ashes in your firebox to accumulate to a depth of two or three inches; they tend to burn themselves up. When the fire has burned down and cooled, remove any excess ashes but leave an ash bed approximately 1 inch deep on the firebox bottom to help maintain a hot charcoal bed.

PEDESTAL UNITS WITH ASH PAN

To use your ash pan, pull the ash dump handle forward (FIGURE 31), rotate approximately 90° counterclockwise to the open position. Rake the excess ashes into the ash pan. Close the ash well.

NEVER OPERATE YOUR STOVE WITH THE ASH WELL IN AN OPEN POSITION.

This creates a fire hazard that may result in a house/chimney fire, internal damage to the stove or discoloration to the gold plated door (plated finishes are not covered by the warranty). To ensure that the ash well is fully closed, allow the door to snap shut, dislodging anything that may be stuck at the opening. Flip the cover up onto the ash pan when transporting the ashes to a closed container with a tight fitting lid for storage.

Carry the ash pan using the front and back handles.

* FIGURE 31.

UNITS WITHOUT ASH PAN

Since these models have no ash pan, shovel some ashes out through the door into a metal container with a tight fitting lid. Leave an ash bed approximately 1 inch deep on the firebox bottom to help maintain a hot charcoal bed. Keep the closed container on a noncombustible floor or ground, well away from all combustible materials. The ashes should be retained in the closed container until all cinders have thoroughly cooled. Cold wood ashes can be used on the garden or in the compost.

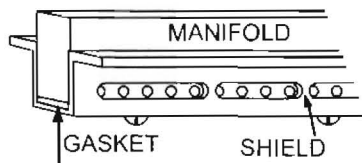

FIGURE 32

LEG UNITS WITH ASH PAN

1. To remove the ashes, clear the ash away from the ash plug.

2. Remove the ash plug. *It is recommended to use a poker.*

3. Rake the excess ash into the ash drawer.

Do not overfill the ash drawer. Ash should not accumulate higher than the sides of the drawer.

4. Before removing the drawer, ensure that the area around the ash opening is clean. Tap the ash from the chute into the drawer, then place the ash plug back over opening.

Never operate your stove with the ash plug removed.

MAINTENANCE

Check your chimney and chimney connector for creosote and soot buildup weekly until a safe frequency for cleaning is established. If accumulation is excessive, disconnect the stove and clean both the chimney and the stove. You may want to call a professional chimney sweep to clean them. Both have to be cleaned at least once a year or as often as necessary.

Remove fibre baffles and clean above them once a year. Replace any broken bricks.

CREOSOTE FORMATION AND REMOVAL

When wood is burned slowly, it produces tar and other organic vapours which combine with expelled moisture to form creosote. These vapours condense in the relatively cooler chimney flue of a slow burning fire and when ignited, make an extremely hot fire. So, the smoke pipe and chimney should be inspected monthly during the heating season to determine if a buildup has occurred. If creosote has accumulated it should be removed to reduce the risk of a chimney fire.

RUNAWAY OR CHIMNEY FIRE

Runaway fires can be the result of **three** major factors:

1. Using incorrect fuel, or small fuel pieces which wood normally be used as kindling.
2. Leaving the door ajar too long and creating extreme temperatures as the air rushes in the open door.
3. Burning your stove with the ash dump door open.

SOLUTIONS:

1. Do not burn treated or processed wood, coal, charcoal, coloured paper or cardboard.
2. Be careful not to over-fire the unit by leaving the door open too long after initial start-up. A thermometer on the chimney connector and/or stove top helps.
3. Always operate the stove with the ash well in a closed position.

WHAT TO DO IF A RUNAWAY OR CHIMNEY FIRE STARTS

1. Close the door and draft fully.
2. Call local fire department.
3. Examine flue-pipes, chimney, attic, and roof of the house, to see if any part has become hot enough to catch fire. If necessary spray with a fire extinguisher or water from a garden hose.
4. Do not operate the stove again until you are certain the chimney and its lining have not been damaged.

GASKET REPLACEMENT

At the end of each burning season inspect the shield and gasket below the manifold for warping or deterioration. Replace if necessary. Both are held to the manifold with machine screws. The shield and the 1/8" fibre cloth gasket are available from your Wolf Steel Ltd. dealer. See FIGURE 32. At this time also check that the door gasket is not worn or loose. Replace with 3/8" high density fiberglass rope if necessary.

The airwash gasket and shield above the door should also be inspected and replaced if deteriorated.

NOTE: DO NOT OPERATE UNIT IF GASKET, MANIFOLD SHIELD OR FIBRE BAFFLE IS DETERIOTATED OR MISSING.

DOOR REMOVAL (1100C ONLY)

1. Remove cast top.
2. Pull pin from top door hinge. It is important to hold the door while removing the pin. Pivot the door to clear the top door hinge. Lift the door off of the lower pin. Do not pivot the door any further than necessary.

WOOD PILE MAINTENANCE

Burn only dry, clean unpainted wood that has been seasoned. It produces more heat and less soot or creosote. Freshly cut wood contains about 50% moisture while after proper seasoning only about 20% of the water remains. As wood is burned, this water boils off consuming energy that should be used in heating. The wetter the wood, the less heat is given off and the more creosote is produced.

Both hardwood and softwood burn equally well in this stove but hardwood is denser, will weigh more per cord and burn a little slower and longer. Firewood should be split, stacked in a manner that air can get to all parts of it and covered in early spring to be ready for burning that fall. Dry firewood has cracks in the end grain. Cut the wood so that it will fit horizontally, front to back, making for easier loading and less of a likelihood that the wood will roll onto the glass. Ideal lengths of wood are approximately 12" for EPA 1100, 1100C, 1100L, 1150 and 1101, 16 1/2" for EPA 1400, 1400L and 1402, 1450 and 21" for EPA 1900.

DO'S

1. Build a hot fire
2. Use only dry wood.
3. Several pieces of medium sized wood are better than a few big pieces.
4. Clean chimney regularly.
5. Refuel frequently using medium sized wood.
6. "Fine Tune" the air settings for optimum performance.

DON'TS

1. Take ash out immediately. Let it accumulate to a depth of at least one inch. A good ash layer provides for a longer lasting and better burning fire.
2. Burn wet wood.
3. Close the door too soon or damper down too quickly.
4. Burn one large log rather than two or three smaller, more reasonably sized logs.
5. Burn at continually "low setting", if glass door is constantly blackened. This means the firebox temperature is too low.

REPLACEMENTS

Contact your dealer for questions concerning prices and availability of replacement parts. Normally all parts can be ordered through your Napoleon dealer or distributor.

When ordering replacement parts always give the following information:

FOR WARRANTY REPLACEMENT PARTS, A PHOTOCOPY OF THE ORIGINAL INVOICE WILL BE REQUIRED TO HONOUR THE CLAIM.

REPLACEMENT PARTS

#	PART NO.	DESCRIPTION
1	W325-0002	SPRING HANDLE - SMALL
2	W325-0007	SPRING HANDLE - LARGE
3*	W090-0001	BRICK - # 1
4*	W090-0002	BRICK - # 2
5*	W090-0004	BRICK - # 4 LEFT
6*	W090-0005	BRICK - # 4 RIGHT
7*	W090-0015	BRICK - # 7
8*	W090-0018	BRICK - # 8
9*	W090-0019	BRICK - # 9
10	W715-0073	ASH FENDER TRIM c/w CORNER BRACKETS
11*	W160-0014	SPRING CLIP FOR ASH FENDER
12	W010-0347	AIRWASH GASKET & SHIELD
13*	W570-0007	SCREWS FOR MANIFOLD & SHIELD
14	GZ551	REPLACEMENT FAN

1100 COMPONENTS

21*	W090-0003	BRICK - # 3
22*	W090-0016	BRICK - # 5
23*	W090-0017	BRICK - # 6
24*	W018-0077	# 10 FIBRE BAFFLE
25*	W200-0077	BLACK TRIVET
26*	EP-11MS	MANIFOLD GASKET & SHIELD
27*	W580-0001	COMPLETE BRICK SET
28*	CL28	BLACK CANOPY LOUVRES
29*	CL28G	GOLD PLATED CANOPY LOUVRES
30	W010-0349	PEDESTAL TRIM
31	KB-35	VARIABLE SPEED CONTROL c/w KNOB
32	W010-0243	ASH PAN (NO FRONT PLATE)
33	W325-0011	ASH PAN HANDLE

1400 COMPONENTS

22*	W090-0016	BRICK - # 5
23*	W090-0017	BRICK - # 6
28*	CL28	BLACK CANOPY LOUVRES
29*	CL28G	GOLD PLATED CANOPY LOUVRES
30	W010-0349	PEDESTAL TRIM
31	KB-35	VARIABLE SPEED CONTROL c/w KNOB
32	W010-0243	ASH PAN (NO FRONT PLATE)
33	W325-0011	ASH PAN HANDLE
34*	W018-0078	# 11 FIBRE BAFFLE
35*	W580-0002	COMPLETE BRICK SET
36*	EP-14MS	MANIFOLD GASKET & SHIELD
37*	GS-330K	BLACK TRIVET

1900 COMPONENTS

21*	W090-0003	BRICK - # 3
22*	W090-0016	BRICK - # 5
23*	W090-0017	BRICK - # 6
28*	CL28	BLACK CANOPY LOUVRES
29*	CL28G	GOLD PLATED CANOPY LOUVRES
30	W010-0349	PEDESTAL TRIM
31	KB-35	VARIABLE SPEED CONTROL c/w KNOB
32	W010-0243	ASH PAN (NO FRONT PLATE)
33	W325-0011	ASH PAN HANDLE
37*	GS-330K	BLACK TRIVET
38	W018-0092	# 12 FIBRE BAFFLE
39	W018-0093	# 13 FIBRE BAFFLE
40	W655-0209	BAFFLE SUPPORT BRACKET
41*	W580-0003	COMPLETE BRICK SET
42*	EP-19MS	MANIFOLD GASKET & SHIELD

1101 COMPONENTS

21*	W090-0003	BRICK - # 3
24*	W018-0077	# 10 FIBRE BAFFLE
26*	EP-11MS	MANIFOLD GASKET & SHIELD
43*	W580-0006	COMPLETE BRICK SET
44	W690-0002	HEAT SENSOR
31A	KB-36	VARIABLE SPEED CONTROL c/w KNOB

1. MODEL & SERIAL NUMBER OF FIREPLACE
2. INSTALLATION DATE OF FIREPLACE
3. PART NUMBER
4. DESCRIPTION OF PART
5. FINISH

* IDENTIFIES ITEMS WHICH ARE NOT ILLUSTRATED. FOR FURTHER INFORMATION, CONTACT YOUR NAPOLEON DEALER.

1402 COMPONENTS

31	KB-35	VARIABLE SPEED CONTROL c/w KNOB
34*	W018-0078	# 11 FIBRE BAFFLE
36*	EP-14MS	MANIFOLD GASKET & SHIELD
44	W690-0002	HEAT SENSOR
45*	W580-0005	COMPLETE BRICK SET
46	W510-0001	5/16" PLUG

1100L COMPONENTS

21*	W090-0003	BRICK - # 3
24*	W018-0077	# 10 FIBRE BAFFLE
26*	EP-11MS	MANIFOLD GASKET & SHIELD
31	KB-35	VARIABLE SPEED CONTROL c/w KNOB
45*	W580-0006	COMPLETE BRICK SET
46	W510-0001	5/16" PLUG

1400L COMPONENTS

31	KB-35	VARIABLE SPEED CONTROL c/w KNOB
34*	W018-0078	# 11 FIBRE BAFFLE
36*	EP-14MS	MANIFOLD GASKET & SHIELD
45*	W580-0005	COMPLETE BRICK SET
46	W510-0001	5/16" PLUG

1100C COMPONENTS

15	W135-0143**	CAST TOP
16	W135-0144**	CAST SIDES
17	W135-0145**	CAST ASHLIP
18	W135-0146**	CAST LEG
19	W135-0147**	CAST DOOR
21*	W090-0003	BRICK - # 3
22*	W090-0016	BRICK - # 5
23*	W090-0017	BRICK - # 6
24*	W018-0077	# 10 FIBRE BAFFLE
26*	EP-11MS	MANIFOLD GASKET & SHIELD
27*	W580-0001	COMPLETE BRICK SET
31	KB-35	VARIABLE SPEED CONTROL c/w KNOB

1100C-1 COMPONENTS

87	W135-0282**	CAST TOP
88	W135-0281**	CAST SIDES
89	W135-0278**	CAST ASHLIP
90	W135-0280**	CAST LEG
91	W135-0279**	CAST DOOR
21*	W090-0003	BRICK - # 3
22*	W090-0016	BRICK - # 5
23*	W090-0017	BRICK - # 6
24*	W018-0077	# 10 FIBRE BAFFLE
26*	EP-11MS	MANIFOLD GASKET & SHIELD
27*	W580-0001	COMPLETE BRICK SET
31	KB-35	VARIABLE SPEED CONTROL c/w KNOB

1150 COMPONENTS

21*	W090-0003	BRICK - # 3
22*	W090-0016	BRICK - # 5
23*	W090-0017	BRICK - # 6
24*	W018-0077	# 10 FIBRE BAFFLE
27*	W580-0001	COMPLETE BRICK SET
47	W525-0024	POT FENDER
48	W325-0041	ASH DRAWER HANDLE
49	W710-0027	ASH DRAWER
50*	W715-0641	PEDESTAL TRIM
51*	W290-0101	LID GASKET
52	W135-0234	CAST - FIREBOX TOP
53	W135-0235	CAST - LID
54	W135-0236	CAST - FLUE COLLAR
55	W135-0237	CAST - PEDESTAL BASE
56	W135-0238	CAST - ASH TRAY
57*	W325-0040	HANDLE - LID LIFTER

**FOR AVAILABLE PORCELAIN COLOURS, ADD THESE LETTERS TO THE BASE PART NUMBER.

GREEN	- F
BROWN	- N
BLACK	- K
ALMOND	- S

ACCESSORIES

#	PART NO.	DESCRIPTION
58	H222G	GOLD PLATED DOOR
58	H222	BLACK DOOR
58	H222SS	BRUSHED STAINLESS STEEL DOOR - STANDARD ARCH
59	H222W	BLACK DOOR - EARLY AMERICAN
59	H222GW	GOLD DOOR - EARLY AMERICAN
59	H222SSW	BRUSHED STAINLESS STEEL DOOR - EARLY AMERICAN
60	W010-1071	DOOR GLASS w/ GASKET
61*	W020-0043	DOOR GASKET
62*	W020-0050	GLASS GASKET
63	CISK**	CAST IRON SURROUND KIT, PAINTED BLACK
64	CISK**A	CAST IRON SURROUND KIT, ENAMEL PORCELAIN
65	EPAD-KT	ASH DRAWER KIT - LEG MODELS

1100 COMPONENTS

66	GS200-G	ORNAMENTAL TRIVET
67	EP62-1	VARIABLE SPEED BLOWER
68*	W500-0064	FRESH AIR COVER PLATE
69*	111KT	OUTSIDE AIR KIT
70*	W470-0002	ENAMEL TOUCH UP & BRUSH (SPECIFY COLOUR)

1400 COMPONENTS

67	EP62-1	VARIABLE SPEED BLOWER
68*	W500-0064	FRESH AIR COVER PLATE
69*	111KT	OUTSIDE AIR KIT
70*	W470-0002	ENAMEL TOUCH UP & BRUSH (SPECIFY COLOUR)
71*	GS-330G	GOLD PLATED TRIVET
72*	GS-530G	ORNAMENTAL TRIVET

1900 COMPONENTS

67	EP62-1	VARIABLE SPEED BLOWER
68*	W500-0064	FRESH AIR COVER PLATE
69*	111KT	OUTSIDE AIR KIT
70*	W470-0002	ENAMEL TOUCH UP & BRUSH (SPECIFY COLOUR)
71*	GS-330G	GOLD PLATED TRIVET
72*	GS-530G	ORNAMENTAL TRIVET

1101 COMPONENTS

73	AK-1	ADAPTER KIT FOR CISK
74	EI-900K10	10" FLASHING KIT C/W BULL NOSE TRIM

1402 COMPONENTS

70*	W470-0002	ENAMEL TOUCH UP & BRUSH (SPECIFY COLOUR)
75	EPA335KT	LOW CLEARANCE FLUE CONNECTOR
76*	EPI-RK	SOLID BRASS RAILING KIT
77	AK-2	ADAPTER KIT FOR CISK-A

1100L COMPONENTS

67	EP62-1	VARIABLE SPEED BLOWER
78	EPA-RK	SOLID BRASS RAILING KIT
79*	EPLK	AIR CIRCULATION CHAMBER LOUVRES (BLACK)
80*	EPLG	AIR CIRCULATION CHAMBER LOUVRES (GOLD)
81*	EPLSS	AIR CIRCULATION CHAMBER LOUVRES (BRUSHED STAINLESS STEEL)
82	W320-0011	BLOWER GUARD
83*	EP36	THERMOSTATIC SENSOR CONTROL KIT
84	200K	TRADITIONAL STEEL LEGS (BLACK)
85	202CK	ORNAMENTAL CAST IRON LEGS
85	202CG	ORNAMENTAL CAST IRON LEGS (GOLD PLATE)
85	202CSS	ORNAMENTAL CAST IRON LEGS (BRUSHED STAINLESS STEEL)

1400L COMPONENTS

67	EP62-1	VARIABLE SPEED BLOWER
78	EPA-RK	SOLID BRASS RAILING KIT
79*	EPLK	AIR CIRCULATION CHAMBER LOUVRES (BLACK)
80*	EPLG	AIR CIRCULATION CHAMBER LOUVRES (GOLD)
81*	EPLSS	AIR CIRCULATION CHAMBER LOUVRES (BRUSHED STAINLESS STEEL)
82	W320-0011	BLOWER GUARD
83*	EP36	THERMOSTATIC SENSOR CONTROL KIT
84	200K	TRADITIONAL STEEL LEGS (BLACK)
85	202CK	ORNAMENTAL CAST IRON LEGS
85	202CG	ORNAMENTAL CAST IRON LEGS (GOLD PLATE)
85	202CSS	ORNAMENTAL CAST IRON LEGS (BRUSHED STAINLESS STEEL)

1150 COMPONENTS

1	W325-0033	SPRING DOOR HANDLE (LARGE) - SATIN CHROME
2	W325-0032	SPRING DOOR HANDLE (SMALL) - SATIN CHROME
69*	111KT	OUTSIDE AIR KIT
86	EP65	BLOWER KIT

1450 COMPONENTS

66	GS200-G	ORNAMENTAL TRIVET
67	EP62-1	VARIABLE SPEED BLOWER
68	W500-0064	FRESH AIR COVER PLATE

**FOR AVAILABLE PORCELAIN COLOURS,
ADD THESE LETTERS TO THE BASE PART NUMBER:

GREEN	- F
BROWN	- N
BLACK	- K
ALMOND	- S

272 0007001

STATE OF MAINE CHIMNEY OR FIREPLACE CONSTRUCTION/INSTALLATION DISCLOSURE

Dear Consumer: State law, specifically 32 M.R.S.A. § 2313-A, requires that chimney or fireplace installers, as of January 1, 1992, provide you with this "Disclosure" prior to the installation or construction of your chimney or fireplace. The purpose of this Disclosure is to inform you that the National Fire Protection Standard #211 (NFPA #211) is the current standard which applies to all new construction of chimneys and fireplaces. Please note that the State of Maine does not require registration or licensure of chimney or fireplace installers. It is important to realize that many fires are caused each year from improperly constructed fireplaces and chimneys. This disclosure form should help you in making an informed decision as to the abilities of the installer and under what requirements the installation must comply.

INSTALLER INFORMATION

Name of Installer: <i>Unknown</i>		D/B/A: <i>Pre-existing Chimney</i>	
Name of Installer (if incorporated):		D/B/A:	
Legal Address:			
City:	State:	Zip Code:	
County:	Home Telephone: () -		
	Work Telephone: () -		
Years of experience doing fireplace or chimney installations:			

CONSUMER INFORMATION

Name of Consumer: <i>Robert Zweifel</i>		
Mailing Address: <i>68 Birchvale Dr</i>		
City: <i>Portland</i>	State: <i>ME</i>	Zip Code: <i>04102</i>
County: <i>Cumberland</i>	Home Telephone: (207) 541 - 9538	
	Work Telephone: (408) 568 - 4625	

Installer, please give a brief description of installation being offered: _____

I hereby attest that the preceding information provided is true to the best of my knowledge. I also understand that if I fail to conform with the standards as outlined in NFPA #211 that I shall be subject to penalties as outlined in Title 32, M.R.S.A., Chapter 33 and the Oil and Solid Fuel Board Rules.

Signature of Installer: *Unknown PS* Date: *01/07/2011*

INSTALLATION STANDARDS

The 1996 Edition of NFPA #211 contains provisions for chimney, fireplaces, venting systems, and solid fuel burning appliances including their installations. The standards applies to residential as well as commercial and industrial installations.

PLEASE CHECK THE TYPE OF CONSTRUCTION TO BE BUILT:

Factory-Built Chimney and Chimney Units.

Factory-built chimney and chimney units shall be listed and installed in accordance with the temperature conditions of the listing, the manufacturer's instructions and all applicable sections of NFPA #211.

Factory-Built Fireplaces.

Factory-built fireplaces shall be listed and shall be installed in accordance with the terms of the listing. Hearth extensions shall be provided in accordance with the manufacturer's instructions or shall be of masonry on non combustible construction in accordance with applicable sections of NFPA #211.

Unlisted Metal Chimney (smokestacks) for Non Residential Applications.

Single wall metal chimneys or unlisted metal chimneys shall not be used inside or outside of one and two family dwellings. Metal chimneys shall be constructed and installed in accordance with the appropriate sections of NFPA #211

Masonry Chimney.

Masonry chimneys shall be constructed by appropriate sections of NFPA #211 for proper design, support, re-enforced, and installation..

Masonry Fireplace.

Masonry fireplaces shall comply with all requirements of NFPA #211 and all other pertinent sections.

CONSUMER CHECKLIST

1. Has the installer provided you with a written contract? 10 M.R.S.A., Chapter 219-A requires written contracts for any home remodeling or construction with an estimated cost in excess of \$3,000.
2. Have you asked the local fire department or code enforcement officials to inspect the installation during and after construction?
3. Is the installer familiar with current NFPA #211 standards and does he have a copy of same?
4. Have you asked for references to be provided by the installer?

