



# CITY MULTI

Air-Conditioners  
INDOOR UNIT

PEFY-P06,08,12,15,18,24,27,30,36,48,54NMAU-E3

---

## INSTALLATION MANUAL

For safe and correct use, please read this installation manual thoroughly before installing the air-conditioner unit.

## MANUEL D'INSTALLATION

Veuillez lire le manuel d'installation en entier avant d'installer ce climatiseur pour éviter tout accident et vous assurer d'une utilisation correcte.

GB

F

AHU-1 M# PEFY-P18NMAU-E3  
(10) units

AHU-2 M# PEFY-P15NMAU-E3  
(3) units

[Fig. 3.2.1]

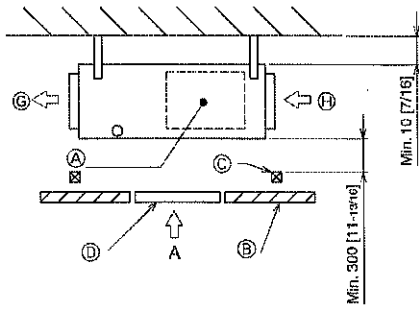

[Fig. 3.2.2]

(Viewed from the direction of the arrow A)

(Unit: mm [in])

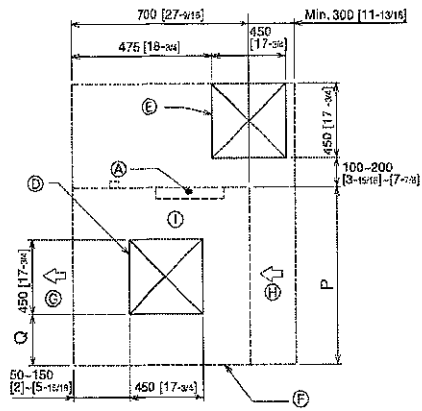

[Fig. 3.2.3]

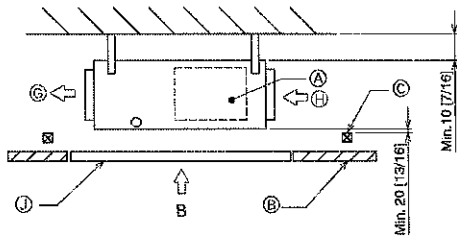

[Fig. 3.2.4]

(Viewed from the direction of the arrow B)

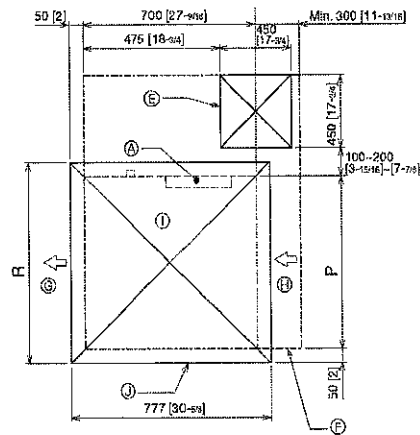

[Fig. 3.2.5]

(Viewed from the direction of the arrow B)

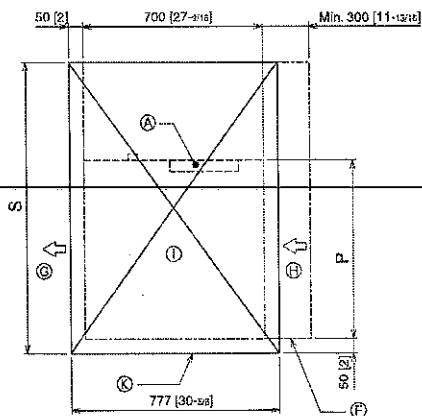

- Ⓐ Electric box
- Ⓑ Ceiling
- Ⓒ Ceiling beam
- Ⓓ Access door 2 (450 mm x 450 mm [17-3/4 in x 17-3/4 in])
- Ⓔ Access door 1 (450 mm x 450 mm [17-3/4 in x 17-3/4 in])
- Ⓕ Maintenance access space
- Ⓖ Supply air
- Ⓗ Intake air
- Ⓢ Bottom of indoor unit
- Ⓣ Access door 3
- Ⓤ Access door 4

(Unit: mm [in])

Model	P	Q	R	S
PEFY-P06,08,12NMAU-E3	700 [27-9/16]	50-150 [2]-[5-15/16]	800 [31-1/2]	1300 [51-3/16]
PEFY-P15,18NMAU-E3	900 [35-7/16]	150-250 [5-15/16]-[9-7/8]	1000 [39-3/8]	1500 [59-1/16]
PEFY-P24,27,30NMAU-E3	1100 [43-5/16]	250-350 [9-7/8]-[13-13/16]	1200 [47-1/4]	1700 [66-15/16]
PEFY-P36,48NMAU-E3	1400 [55-1/8]	400-500 [15-3/4]-[19-11/16]	1500 [59-1/16]	2000 [78-3/4]
PEFY-P54NMAU-E3	1600 [63]	500-600 [19-11/16]-[23-5/8]	1700 [66-15/16]	2200 [86-5/8]

4

4.1

[Fig. 4.1.1]

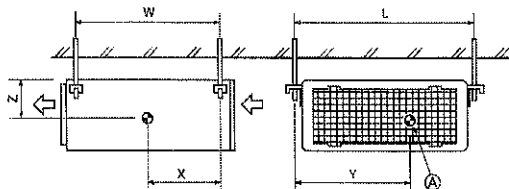

Ⓐ Center of gravity

5

5.1

[Fig. 5.1.1]

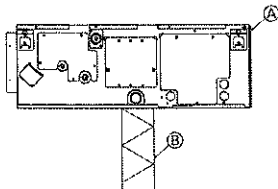

Ⓐ Unit body  
Ⓑ Lifting machine

[Fig. 5.1.2]

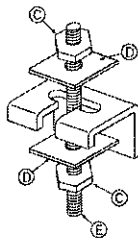

Ⓒ Nuts (field supply)  
Ⓓ Washers (square) (accessory)  
Ⓔ M10 hanging bolt (field supply)

5.2

[Fig. 5.2.1]

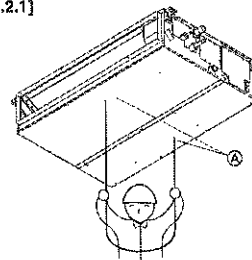

Ⓐ Indoor unit's bottom surface

6

6.2

[Fig. 6.2.1]

(Unit: mm [in])

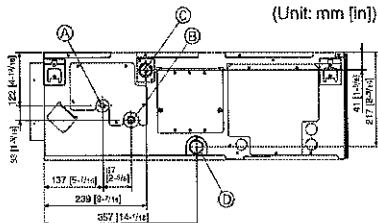

Ⓐ Refrigerant pipe (liquid pipe)  
Ⓑ Refrigerant pipe (gas pipe)  
Ⓒ Drain pipe (O.D. ø32 mm [1-1/4 in])  
Ⓓ Drain pipe (O.D. ø32 mm [1-1/4 in], spontaneous draining)

[Fig. 7.1.1]

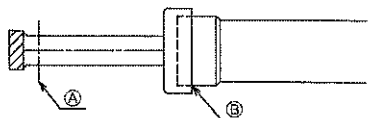

- Ⓐ Cut here
- Ⓑ Remove brazed cap

[Fig. 7.1.2]

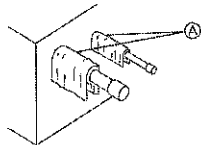

- Ⓐ Cool by a wet cloth

[Fig. 7.1.3]

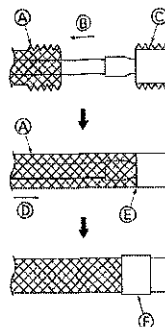

- Ⓐ Thermal insulation
- Ⓑ Pull out insulation
- Ⓒ Wrap with damp cloth
- Ⓓ Return to original position
- Ⓔ Ensure that there is no gap here
- Ⓕ Wrap with insulating tape

7.2

[Fig. 7.2.1]

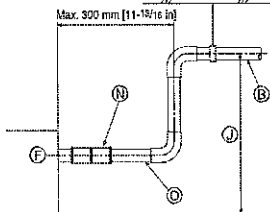
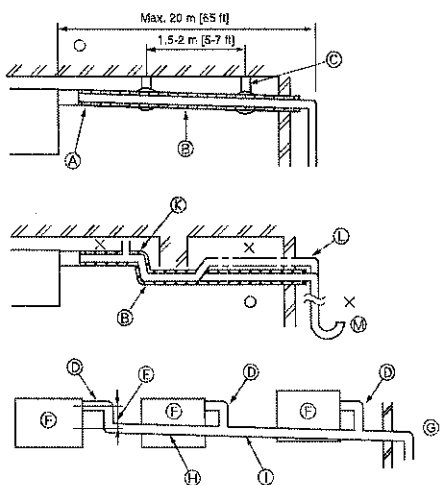

- Correct piping
  - × Wrong piping
  - Ⓐ Insulation (9 mm [3/8 in] or more)
  - Ⓑ Downward slope (1/100 or more)
  - Ⓒ Support metal
  - Ⓓ Air bleeder
  - Ⓔ Raised
  - Ⓕ Odor trap
- Grouped piping
- Ⓖ O. D. ø32 mm [1-1/4 in] PVC TUBE
  - Ⓗ Make it as large as possible. About 10 cm [3-15/16 in].
  - Ⓘ Indoor unit
  - Ⓚ Make the piping size large for grouped piping.
  - Ⓛ Downward slope (1/100 or more)
  - Ⓜ O. D. ø38 mm [1-1/2 in] PVC TUBE for grouped piping. (9 mm [3/8 in] or more insulation)
  - Ⓨ Up to 700 mm [27-9/16 in]
  - Ⓩ Drain hose (accessory)
  - ⓐ Horizontal or slightly upgradient

[Fig. 7.2.2]

(Unit: mm [in])

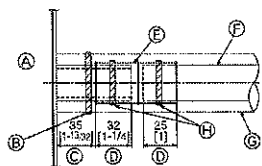

- Ⓐ Indoor unit
- Ⓑ Tie band (accessory)
- Ⓒ Visible part
- Ⓓ Insertion margin
- Ⓔ Drain hose (accessory)
- Ⓕ Drain pipe (O.D. ø32 mm [1-1/4 in] PVC TUBE, field supply)
- Ⓖ Insulating material (field supply)
- Ⓗ Tie band (accessory)

### 7.3

[Fig. 7.3.1]

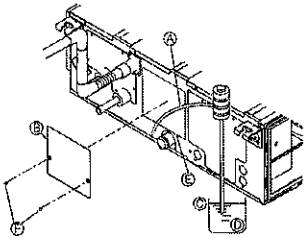

- Ⓐ Insert pump's end 2 to 4 cm (13/16 to 1-5/8 in).
- Ⓑ Remove the water supply port.
- Ⓒ About 2500 cc
- Ⓓ Water
- Ⓔ Filling port
- Ⓕ Screw

[Fig. 7.3.2]

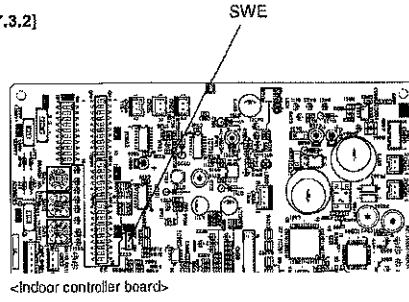

### 8

[Fig. 8.0.1]

<A> In case of rear inlet

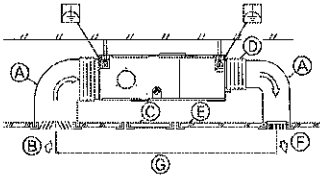

- Ⓐ Duct
- Ⓑ Air inlet
- Ⓒ Access door
- Ⓓ Canvas duct
- Ⓔ Ceiling surface
- Ⓕ Air outlet
- Ⓖ Leave distance enough to prevent short cycle

<B> In case of bottom inlet

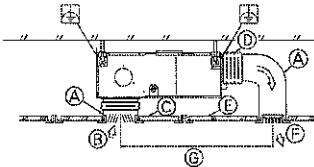

[Fig. 8.0.2]

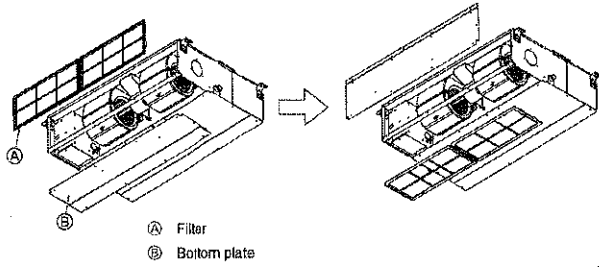

[Fig. 8.0.4]

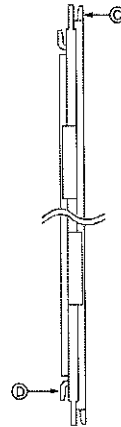

[Fig. 8.0.3]

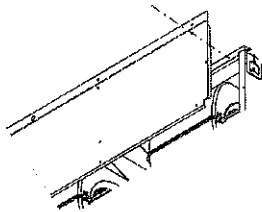

### 9

#### 9.1

[Fig. 9.1.1]

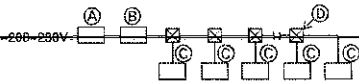

- Ⓐ Ground-fault interrupter
- Ⓑ Local switch/Wiring breaker
- Ⓒ Indoor unit
- Ⓓ Pull box

#### 9.2

[Fig. 9.2.1]

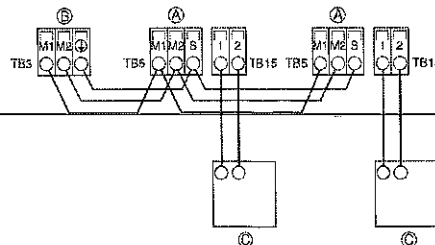

[Fig. 9.2.2]

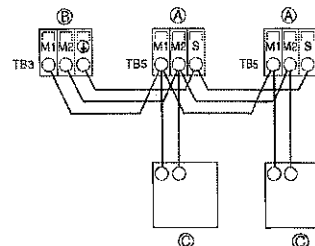

- Ⓐ Terminal block for indoor transmission cable
- Ⓑ Terminal block for outdoor transmission cable
- Ⓒ Remote controller

## 9.2

[Fig. 9.2.3]

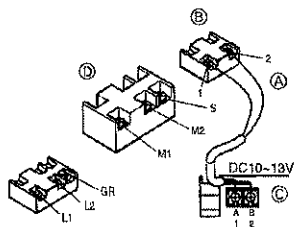

[Fig. 9.2.4]

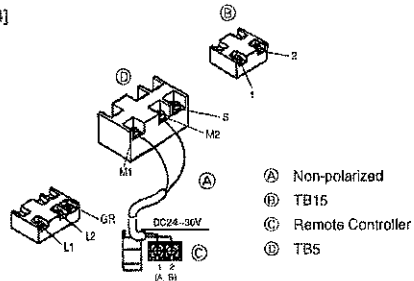

- (A) Non-polarized
- (B) TB15
- (C) Remote Controller
- (D) TB5

## 9.3

[Fig. 9.3.1]

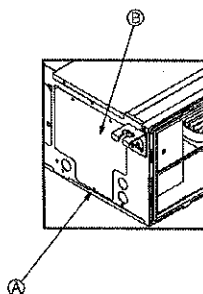

- (A) Screw holding cover (1pc)
- (B) Cover

[Fig. 9.3.2]

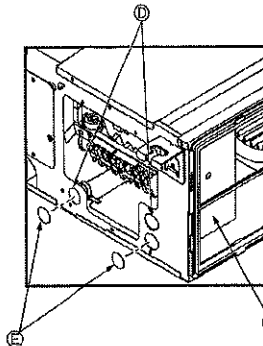

- (C) Terminal box
- (D) Knockout hole
- (E) Remove

[Fig. 9.3.3]

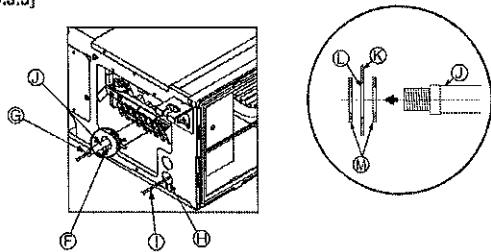

(G) Use PG bushing to keep the weight of the cable and external force from being applied to the power supply terminal connector. Use a cable tie to secure the cable.

- (G) Power source wiring
- (H) Side frame
- (I) Use ordinary bushing
- (J) Knockout hole (for power source wiring)
- (K) Transmission wiring
- (L) Washer (round) (accessory)
- (M) Conduit

[Fig. 9.3.4]

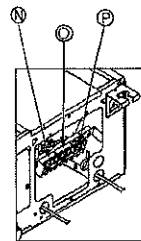

- (N) Terminal block for power source
- (O) Terminal block for indoor transmission
- (P) Terminal block for remote controller

[Fig. 9.3.5]

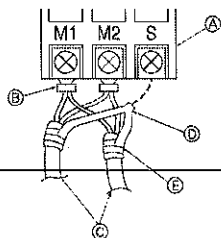

- (A) Terminal block
- (B) Round terminal
- (C) Shield wire
- (D) The earth wire from two cables are connected together to the S terminal. (Dead-end connection)
- (E) Insulation tape (To keep the earth wire of the shielded cable from coming in contact with the transmission terminal)

## 9.5

[Fig. 9.5.1]

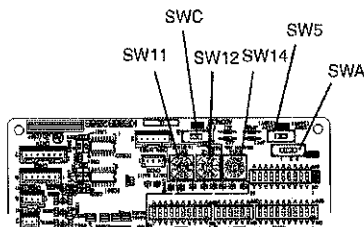

<Indoor controller board>

# Contents

1. Safety precautions.....	7	6. Refrigerant pipe and drain pipe specifications .....	9
1.1. Before installation and electric work .....	7	6.1. Refrigerant pipe and drain pipe specifications .....	10
1.2. Precautions for devices that use R410A refrigerant.....	7	6.2. Refrigerant pipe, drain pipe.....	10
1.3. Before getting installed .....	8	7. Connecting refrigerant pipes and drain pipes.....	10
1.4. Before getting installed (moved) - electrical work .....	8	7.1. Refrigerant piping work.....	10
1.5. Before starting the test run .....	8	7.2. Drain piping work .....	10
2. Indoor unit accessories .....	8	7.3. Confirming drain discharge .....	11
3. Selecting an installation site.....	8	8. Duct work .....	11
3.1. Install the indoor unit on a ceiling strong enough to sustain its weight .....	9	9. Electrical wiring .....	12
3.2. Securing installation and service space.....	9	9.1. Power supply wiring .....	12
3.3. Combining indoor units with outdoor units .....	9	9.2. Connecting remote controller, indoor and outdoor transmission cables .....	13
4. Fixing hanging bolts .....	9	9.3. Connecting electrical connections .....	13
4.1. Fixing hanging bolts.....	9	9.4. External I/O specifications .....	13
5. Installing the unit .....	9	9.5. Selecting the external static pressure.....	14
5.1. Hanging the unit body.....	9	9.6. Setting addresses .....	14
5.2. Confirming the unit's position and fixing hanging bolts.....	9	9.7. Sensing room temperature with the built-in sensor in a remote controller.....	14
		9.8. Changing the power voltage setting.....	14
		9.9. Electrical characteristics .....	14

Note: If you use other remote controllers, refer to either Installation Manual or Initial Setting Manual that comes with the controller to be used.

GB

## 1. Safety precautions

### 1.1. Before installation and electric work





- ▶ Before installing the unit, make sure you read all the "Safety precautions".
- ▶ The "Safety precautions" provide very important points regarding safety. Make sure you follow them.

#### Symbols used in the text

 **Warning:**  
Describes precautions that should be observed to prevent danger of injury or death to the user.

 **Caution:**  
Describes precautions that should be observed to prevent damage to the unit.

#### Symbols used in the illustrations

-  : Indicates an action that must be avoided.
-  : Indicates that important instructions must be followed.
-  : Indicates a part which must be grounded.
-  : Indicates that caution should be taken with rotating parts. (This symbol is displayed on the main unit label.) <Color: yellow>
-  : Beware of electric shock (This symbol is displayed on the main unit label.) <Color: yellow>

 **Warning:**  
Carefully read the labels affixed to the main unit.

-  **Warning:**
  - Ask the dealer or an authorized technician to install the air conditioner.
    - Improper installation by the user may result in water leakage, electric shock, or fire.
  - This appliance is not intended for use by persons (including children) with reduced physical, sensory or mental capabilities, or lack of experience and knowledge, unless they have been given supervision or instruction concerning use of the appliance by a person responsible for their safety.
  - Install the air unit at a place that can withstand its weight.
    - Inadequate strength may cause the unit to fall down, resulting in injuries.
  - Use the specified cables for wiring. Make the connections securely so that the outside force of the cable is not applied to the terminals.
    - Inadequate connection and fastening may generate heat and cause a fire.
  - Prepare for typhoons and other strong winds and earthquakes and install the unit at the specified place.
    - Improper installation may cause the unit to topple and result in injury.
  - Always use an air cleaner, humidifier, electric heater, and other accessories specified by Mitsubishi Electric.
    - Ask an authorized technician to install the accessories. Improper installation by the user may result in water leakage, electric shock, or fire.
  - Never repair the unit. If the air conditioner must be repaired, consult the dealer.
    - If the unit is repaired improperly, water leakage, electric shock, or fire may result.

- If the supply cord is damaged, it must be replaced by the manufacturer, its service agent or similarly qualified persons in order to avoid a hazard.
- Do not touch the heat exchanger fins.
  - Improper handling may result in injury.
- When handling this product, always wear protective equipment.
  - EG: Gloves, full arm protection namely boiler suit, and safety glasses.
    - Improper handling may result in injury.
- If refrigerant gas leaks during installation work, ventilate the room.
  - If the refrigerant gas comes into contact with a flame, poisonous gases will be released.
- Install the air conditioner according to this Installation Manual.
  - If the unit is installed improperly, water leakage, electric shock, or fire may result.
- Have all electric work done by a licensed electrician according to "Electric Facility Engineering Standard" and "Interior Wire Regulations" and the instructions given in this manual and always use a special circuit.
  - If the power source capacity is inadequate or electric work is performed improperly, electric shock and fire may result.
- Keep the electric parts away from water (washing water etc.).
  - It might result in electric shock, catching fire or smoke.
- Securely install the outdoor unit terminal cover (panel).
  - If the terminal cover (panel) is not installed properly, dust or water may enter the outdoor unit and fire or electric shock may result.
- Do not use refrigerant other than the type indicated in the manuals provided with the unit and on the nameplate.
  - Doing so may cause the unit or pipes to burst, or result in explosion or fire during use, during repair, or at the time of disposal of the unit.
  - It may also be in violation of applicable laws.
  - MITSUBISHI ELECTRIC CORPORATION cannot be held responsible for malfunctions or accidents resulting from the use of the wrong type of refrigerant.
- If the air conditioner is installed in a small room, measures must be taken to prevent the refrigerant concentration from exceeding the safety limit even if the refrigerant should leak.
  - Consult the dealer regarding the appropriate measures to prevent the safety limit from being exceeded. Should the refrigerant leak and cause the safety limit to be exceeded, hazards due to lack of oxygen in the room could result.
- When moving and reinstalling the air conditioner, consult the dealer or an authorized technician.
  - If the air conditioner is installed improperly, water leakage, electric shock, or fire may result.
- After completing installation work, make sure that refrigerant gas is not leaking.
  - If the refrigerant gas leaks and is exposed to a fan heater, stove, oven, or other heat source, it may generate noxious gases.
- Do not reconstruct or change the settings of the protection devices.
  - If the pressure switch, thermal switch, or other protection device is shorted and operated forcibly, or parts other than those specified by Mitsubishi Electric are used, fire or explosion may result.
- To dispose of this product, consult your dealer.
- Do not use a leak detection additive.

### 1.2. Precautions for devices that use R410A refrigerant

-  **Caution:**
  - Do not use the existing refrigerant piping.
    - The old refrigerant and refrigerant oil in the existing piping contains a large amount of chlorine which may cause the refrigerant oil of the new unit to deteriorate.

- Use refrigerant piping made of C1220 (Cu-DHP) phosphorus deoxidized copper as specified in the JIS H3300 "Copper and copper alloy seamless pipes and tubes". In addition, be sure that the inner and outer surfaces of the pipes are clean and free of hazardous sulphur, oxides, dust/dirt, shaving particles, oils, moisture, or any other contaminant.
  - Contaminants on the inside of the refrigerant piping may cause the refrigerant residual oil to deteriorate.
- Store the piping to be used during installation indoors and keep both ends of the piping sealed until just before brazing. (Store elbows and other joints in a plastic bag.)
  - If dust, dirt, or water enters the refrigerant cycle, deterioration of the oil and compressor trouble may result.
- Use liquid refrigerant to fill the system.
  - If gas refrigerant is used to seal the system, the composition of the refrigerant in the cylinder will change and performance may drop.
- Do not use a refrigerant other than R410A.
  - If another refrigerant (R22, etc.) is used, the chlorine in the refrigerant may cause the refrigerator oil to deteriorate.
- Use a vacuum pump with a reverse flow check valve.
  - The vacuum pump oil may flow back into the refrigerant cycle and cause the refrigerator oil to deteriorate.
- Do not use the following tools that are used with conventional refrigerants. (Gauge manifold, charge hose, gas leak detector, reverse flow check valve, refrigerant charge base, vacuum gauge, refrigerant recovery equipment)
  - If the conventional refrigerant and refrigerator oil are mixed in the R410A, the refrigerant may deteriorate.
  - If water is mixed in the R410A, the refrigerator oil may deteriorate.
  - Since R410A does not contain any chlorine, gas leak detectors for conventional refrigerants will not react to it.
- Do not use a charging cylinder.
  - Using a charging cylinder may cause the refrigerant to deteriorate.
- Be especially careful when managing the tools.
  - If dust, dirt, or water gets in the refrigerant cycle, the refrigerant may deteriorate.

### 1.3. Before getting installed

#### ⚠ Caution:

- Do not install the unit where combustible gas may leak.
  - If the gas leaks and accumulates around the unit, an explosion may result.
- Do not use the air conditioner where food, pets, plants, precision instruments, or artwork are kept.
  - The quality of the food, etc. may deteriorate.
- Do not use the air conditioner in special environments.
  - Oil, steam, sulfuric smoke, etc. can significantly reduce the performance of the air conditioner or damage its parts.
- When installing the unit in a hospital, communication station, or similar place, provide sufficient protection against noise.
  - The inverter equipment, private power generator, high-frequency medical equipment, or radio communication equipment may cause the air conditioner to operate erroneously, or fail to operate. On the other hand, the air conditioner may affect such equipment by creating noise that disturbs medical treatment or image broadcasting.
- Do not install the unit on a structure that may cause leakage.
  - When the room humidity exceeds 80% or when the drain pipe is clogged, condensation may drip from the indoor unit. Perform collective drainage work together with the outdoor unit, as required.
- The indoor models should be installed the ceiling over than 2.5 m from floor.

## 2. Indoor unit accessories

The unit is provided with the following accessories:

Part No.	Accessories	Qty
1	Tie band	4
2	Drain hose	2
3	Washer (square)	8

## 1.4. Before getting installed (moved) - electrical work

#### ⚠ Caution:

- Ground the unit.
  - Do not connect the ground wire to gas or water pipes, lightning rods, or telephone ground lines. Improper grounding may result in electric shock.
- Install the power cable so that tension is not applied to the cable.
  - Tension may cause the cable to break and generate heat and cause a fire.
- Install a leak circuit breaker, as required.
  - If an leak circuit breaker is not installed, electric shock may result.
- Use power line cables of sufficient current carrying capacity and rating.
  - Cables that are too small may leak, generate heat, and cause a fire.
- Use only a circuit breaker and fuse of the specified capacity.
  - A fuse or circuit breaker of a larger capacity or a steel or copper wire may result in a general unit failure or fire.
- Do not wash the air conditioner units.
  - Washing them may cause an electric shock.
- Be careful that the installation base is not damaged by long use.
  - If the damage is left uncorrected, the unit may fall and cause personal injury or property damage.
- Install the drain piping according to this Installation Manual to ensure proper drainage. Wrap thermal insulation around the pipes to prevent condensation.
  - Improper drain piping may cause water leakage and damage to furniture and other possessions.
- Be very careful about product transportation.
  - Only one person should not carry the product if it weighs more than 20 kg [45 LBS].
  - Some products use PP bands for packaging. Do not use any PP bands for a means of transportation. It is dangerous.
  - Do not touch the heat exchanger fins. Doing so may cut your fingers.
  - When transporting the outdoor unit, suspend it at the specified positions on the unit base. Also support the outdoor unit at four points so that it cannot slip sideways.
- Safely dispose of the packing materials.
  - Packing materials, such as nails and other metal or wooden parts, may cause stabs or other injuries.
  - Tear apart and throw away plastic packaging bags so that children will not play with them. If children play with a plastic bag which was not torn apart, they face the risk of suffocation.

## 1.5. Before starting the test run

#### ⚠ Caution:

- Turn on the power at least 12 hours before starting operation.
  - Starting operation immediately after turning on the main power switch can result in severe damage to internal parts. Keep the power switch turned on during the operational season.
- Do not touch the switches with wet fingers.
  - Touching a switch with wet fingers can cause electric shock.
- Do not touch the refrigerant pipes during and immediately after operation.
  - During and immediately after operation, the refrigerant pipes are may be hot and may be cold, depending on the condition of the refrigerant flowing through the refrigerant piping, compressor, and other refrigerant cycle parts. Your hands may suffer burns or frostbite if you touch the refrigerant pipes.
- Do not operate the air conditioner with the panels and guards removed.
  - Rotating, hot, or high-voltage parts can cause injuries.
- Do not turn off the power immediately after stopping operation.
  - Always wait at least five minutes before turning off the power. Otherwise, water leakage and trouble may occur.

Part No.	Accessories	Qty
4	Installation manual	1
5	Operation manual	1
6	Washer (round)	2

## 3. Selecting an installation site

- Select a site with sturdy fixed surface sufficiently durable against the weight of unit.
- Before installing unit, the routing to carry in unit to the installation site should be determined.
- Select a site where the unit is not affected by entering air.
- Select a site where the flow of supply and return air is not blocked.
- Select a site where refrigerant piping can easily be led to the outside.
- Select a site which allows the supply air to be distributed fully in room.
- Do not install unit at a site with oil splashing or steam in much quantity.
- Do not install unit at a site where combustible gas may generate, flow in, stagnate or leak.
- Do not install unit at a site where equipment generating high frequency waves (a high frequency wave welder for example) is provided.
- Do not install unit at a site where fire detector is located at the supply air side. (Fire detector may operate erroneously due to the heated air supplied during heating operation.)
- When special chemical product may scatter around such as site chemical plants and hospitals, full investigation is required before installing unit. (The plastic components may be damaged depending on the chemical product applied.)



- If the unit is run for long hours when the air above the ceiling is at high temperature/high humidity (dew point above 26°C [79°F]), dew condensation may be produced in the indoor unit. When operating the units in this condition, add insulation material (10-20 mm [13/32 to 13/16 in]) to the entire surface of the indoor unit to avoid dew condensation.

### 3.1. Install the indoor unit on a ceiling strong enough to sustain its weight

#### ⚠ Warning:

The unit must be securely installed on a structure that can sustain its weight. If the unit is mounted on an unstable structure, it may fall down causing injuries.

### 3.2. Securing installation and service space

Secure enough access space to allow for the maintenance, inspection, and replacement of the motor, fan, drain pump, heat exchanger, and electric box in one of the following ways.

Select an installation site for the indoor unit so that its maintenance access space will not be obstructed by beams or other objects.

- (1) When a space of 300 mm [11-13/16 in] or more is available below the unit between the unit and the ceiling (Fig. 3.2.1)
  - Create access door 1 and 2 (450 x 450 mm [17-3/4 x 17-3/4 in] each) as shown in Fig. 3.2.2. (Access door 2 is not required if enough space is available below the unit for a maintenance worker to work in.)

- (2) When a space of less than 300 mm [11-13/16 in] is available below the unit between the unit and the ceiling (At least 20 mm [13/16 in] of space should be left below the unit as shown in Fig. 3.2.3.)
  - Create access door 1 diagonally below the electric box and access door 3 below the unit as shown in Fig. 3.2.4.

or

- Create access door 4 below the electric box and the unit as shown in Fig. 3.2.5.

[Fig. 3.2.1] (P.2)

[Fig. 3.2.2] (Viewed from the direction of the arrow A) (P.2)

[Fig. 3.2.3] (P.2)

[Fig. 3.2.4] (Viewed from the direction of the arrow B) (P.2)

[Fig. 3.2.5] (Viewed from the direction of the arrow B) (P.2)

- Ⓐ Electric box
- Ⓑ Ceiling
- Ⓒ Ceiling beam
- Ⓓ Access door 2 (450 mm x 450 mm [17-3/4 in x 17-3/4 in])
- Ⓔ Access door 1 (450 mm x 450 mm [17-3/4 in x 17-3/4 in])
- Ⓕ Maintenance access space
- Ⓖ Supply air
- Ⓖ Intake air
- Ⓗ Bottom of indoor unit
- Ⓙ Access door 3
- Ⓚ Access door 4

### 3.3. Combining indoor units with outdoor units

For combining indoor units with outdoor units, refer to the outdoor unit installation manual.

## 4. Fixing hanging bolts

### 4.1 Fixing hanging bolts

[Fig. 4.1.1] (P.3)

- Ⓐ Center of gravity

(Give site of suspension strong structure.)

#### Center of gravity and Product Weight

Model name	W (mm [in])	L (mm [in])	X (mm [in])	Y (mm [in])	Z (mm [in])	Product Weight (kg [lb])
PEFY-P06NMAU-E3	643 [25-5/16]	754 [29-11/16]	330 [13]	300 [11-13/16]	130 [5-1/8]	22 [49]
PEFY-P08NMAU-E3	643 [25-5/16]	754 [29-11/16]	330 [13]	300 [11-13/16]	130 [5-1/8]	22 [49]
PEFY-P12NMAU-E3	643 [25-5/16]	754 [29-11/16]	330 [13]	300 [11-13/16]	130 [5-1/8]	22 [49]
PEFY-P15NMAU-E3	643 [25-5/16]	954 [37-9/16]	340 [13-3/8]	375 [14-3/4]	130 [5-1/8]	26 [58]
PEFY-P18NMAU-E3	643 [25-5/16]	954 [37-9/16]	340 [13-3/8]	375 [14-3/4]	130 [5-1/8]	26 [58]
PEFY-P24NMAU-E3	643 [25-5/16]	1154 [45-7/16]	325 [12-13/16]	525 [20-11/16]	130 [5-1/8]	30 [67]
PEFY-P27NMAU-E3	643 [25-5/16]	1154 [45-7/16]	325 [12-13/16]	525 [20-11/16]	130 [5-1/8]	30 [67]
PEFY-P30NMAU-E3	643 [25-5/16]	1154 [45-7/16]	325 [12-13/16]	525 [20-11/16]	130 [5-1/8]	30 [67]
PEFY-P36NMAU-E3	643 [25-5/16]	1454 [57-1/4]	330 [13]	675 [26-9/16]	130 [5-1/8]	39 [86]
PEFY-P48NMAU-E3	643 [25-5/16]	1454 [57-1/4]	330 [13]	675 [26-9/16]	130 [5-1/8]	39 [86]
PEFY-P54NMAU-E3	643 [25-5/16]	1654 [65-1/8]	332 [13-1/16]	725 [28-9/16]	130 [5-1/8]	42 [93]

## 5. Installing the unit

### 5.1. Hanging the unit body

- ▶ Bring the indoor unit to an installation site as it is packed.
- ▶ To hang the indoor unit, use a lifting machine to lift and pass through the hanging bolts.

[Fig. 5.1.1] (P.3)

- Ⓐ Unit body
- Ⓑ Lifting machine

[Fig. 5.1.2] (P.3)

- Ⓒ Nuts (field supply)
- Ⓓ Washers (square) (accessory)
- Ⓔ M10 hanging bolt (field supply)

### 5.2. Confirming the unit's position and fixing hanging bolts

- ▶ Use the gage supplied with the panel to confirm that the unit body and hanging bolts are positioned in place. If they are not positioned in place, it may result in dew drops due to wind leak. Be sure to check the positional relationship.
- ▶ Use a level to check that the surface indicated by Ⓐ is at level. Ensure that the hanging bolt nuts are tightened to fix the hanging bolts.
- ▶ To ensure that drain is discharged, be sure to hang the unit at level using a level.

[Fig. 5.2.1] (P.3)

- Ⓐ Indoor unit's bottom surface



#### ⚠ Caution:

Install the unit in horizontal position. If the side with drain port is installed higher, water leakage may be caused.

## 6. Refrigerant pipe and drain pipe specifications

To avoid dew drops, provide sufficient antisweating and insulating work to the refrigerant and drain pipes.

When using commercially available refrigerant pipes, be sure to wind commercially available insulating material (with a heat-resisting temperature of more than 100°C [212°F] and thickness given below) onto both liquid and gas pipes.

Insulate all indoor pipes with foam polyethylene insulation with a minimum density of 0.03 and a thickness as specified in the table below.

- ① Select the thickness of insulating material by pipe size.

Pipe size	Insulating material's thickness
6.4 mm to 25.4 mm [1/4 to 1 in]	More than 10 mm [7/16 in]
28.6 mm to 38.1 mm [1-1/8 to 1-1/2 in]	More than 15 mm [5/8 in]

- ② If the unit is used on the highest story of a building and under conditions of high temperature and humidity, it is necessary to use pipe size and insulating material's thickness more than those given in the table above.
- ③ If there are customer's specifications, simply follow them.

## 6.1. Refrigerant pipe and drain pipe specifications

(Unit: mm [in])

Item		Model	PEFY-P-NMAU-E2	
			06-08-12-15-18	24-27-30-36-48-54
Refrigerant pipe (Braze connection)	Liquid pipe		ø 6.35 [1/4]	ø 9.52 [3/8]
	Gas pipe		ø 12.7 [1/2]	ø 15.88 [5/8]
Drain pipe			O.D. ø 32 [1-1/4]	

## 6.2. Refrigerant pipe, drain pipe

[Fig. 6.2.1] (P.3)

- Ⓐ Refrigerant pipe (liquid pipe)
- Ⓑ Refrigerant pipe (gas pipe)
- Ⓒ Drain pipe (O.D. ø32 mm [1-1/4 in])
- Ⓓ Drain pipe (O.D. ø32 mm [1-1/4 in], spontaneous draining)

## 7. Connecting refrigerant pipes and drain pipes

### 7.1. Refrigerant piping work

This piping work must be done in accordance with the installation manuals for both outdoor unit and BC controller (simultaneous cooling and heating series R2).

- Series R2 is designed to operate in a system that the refrigerant pipe from an outdoor unit is received by BC controller and branches at the BC controller to connect between indoor units.
- For constraints on pipe length and allowable difference of elevation, refer to the outdoor unit manual.
- The method of pipe connection is brazing connection.

#### ⚠ Caution:

- Install the refrigerant piping for the indoor unit in accordance with the following.

1. Cut the tip of the indoor unit piping, remove the gas, and then remove the brazed cap.

[Fig. 7.1.1] (P.4)

- Ⓐ Cut here
- Ⓑ Remove brazed cap

2. Pull out the thermal insulation on the site refrigerant piping, braze the unit piping, and replace the insulation in its original position. Wrap the piping with insulating tape.

#### Note:

- When brazing the refrigerant pipes, be sure to blaze, after covering a wet cloth to the pipes of the units in order to prevent it from burning and shrinking by heat.

[Fig. 7.1.2] (P.4)

- Ⓐ Cool by a wet cloth

- Pay strict attention when wrapping the copper piping since wrapping the piping may cause condensation instead of preventing it.

[Fig. 7.1.3] (P.4)

- Ⓐ Thermal insulation
- Ⓑ Pull out insulation
- Ⓒ Wrap with damp cloth
- Ⓓ Return to original position
- Ⓔ Ensure that there is no gap here
- Ⓕ Wrap with insulating tape

### Cautions On Refrigerant Piping

- ▶ Be sure to use non-oxidative brazing for brazing to ensure that no foreign matter or moisture enter into the pipe.
- ▶ Be sure to apply refrigerating machine oil over the flare connection seating surface and tighten the connection using a double spanner.
- ▶ Provide a metal brace to support the refrigerant pipe so that no load is imparted to the indoor unit end pipe. This metal brace should be provided 50 cm away from the indoor unit's flare connection.

#### ⚠ Warning:

Do not use refrigerant other than the type indicated in the manuals provided with the unit and on the nameplate.

- Doing so may cause the unit or pipes to burst, or result in explosion or fire during use, during repair, or at the time of disposal of the unit.
- It may also be in violation of applicable laws.
- MITSUBISHI ELECTRIC CORPORATION cannot be held responsible for malfunctions or accidents resulting from the use of the wrong type of refrigerant.

#### ⚠ Caution:

- Use refrigerant piping made of C1220 (Cu-DHP) phosphorus deoxidized copper as specified in the JIS H3300 "Copper and copper alloy seamless pipes and tubes". In addition, be sure that the inner and outer surfaces of the pipes are clean and free of hazardous sulphur, oxides, dust/dirt, shavings particles, oils, moisture, or any other contaminant.

- Never use existing refrigerant piping.

- The large amount of chlorine in conventional refrigerant and refrigerant oil in the existing piping will cause the new refrigerant to deteriorate.
- Store the piping to be used during installation indoors and keep both ends of the piping sealed until just before brazing.
  - If dust, dirt, or water gets into the refrigerant cycle, the oil will deteriorate and the compressor may fail.
- Use Suniso 4GS or 3GS (small amount) refrigerant oil to coat the flare and flange connection part. (For models using R22)
- Use ester oil, ether oil or alkylbenzene (small amount) as the refrigerant oil to coat flares and flange connections. (For models using R410A or R407C)
  - The refrigerant used in the unit is highly hygroscopic and mixes with water and will degrade the refrigerant oil.

### 7.2. Drain piping work

- Ensure that the drain piping is downward (pitch of more than 1/100) to the outdoor (discharge) side. Do not provide any trap or irregularity on the way.
- Ensure that any cross-wise drain piping is less than 20 m [65 ft] (excluding the difference of elevation). If the drain piping is long, provide metal braces to prevent it from waving. Never provide any air vent pipe. Otherwise drain may be ejected.
- Use a hard vinyl chloride pipe O.D. ø32 mm [1-1/4 in] for drain piping.
- Ensure that collected pipes are 10 cm [3-15/16 in] lower than the unit body's drain port.
- Do not provide any odor trap at the drain discharge port.
- Put the end of the drain piping in a position where no odor is generated.
- Do not put the end of the drain piping in any drain where ionic gases are generated.

[Fig. 7.2.1] (P.4)

- Correct piping
- × Wrong piping
- Ⓐ Insulation (9 mm [3/8 in] or more)
- Ⓑ Downward slope (1/100 or more)
- Ⓒ Support metal
- Ⓓ Air bleeder
- Ⓔ Raised
- Ⓕ Odor trap

#### Grouped piping

- Ⓓ O. D. ø32 mm [1-1/4 in] PVC TUBE
- Ⓔ Make it as large as possible. About 10 cm [3-15/16 in].
- Ⓕ Indoor unit
- Ⓖ Make the piping size large for grouped piping.
- Ⓗ Downward slope (1/100 or more)
- Ⓙ O. D. ø38 mm [1-1/2 in] PVC TUBE for grouped piping, (9 mm [3/8 in] or more insulation)
- Ⓚ Up to 700 mm [27-9/16 in]
- Ⓛ Drain hose (accessory)
- Ⓜ Horizontal or slightly upgradient

1. Insert the drain hose (accessory) into the drain port (insertion margin: 32 mm [1-1/4 in]). (The drain hose must not be bent more than 45° to prevent the hose from breaking or clogging.) (Attach the hose with glue, and fix it with the band (accessory).)
2. Attach the drain pipe (O.D. ø32 mm [1-1/4 in] PVC TUBE PV-25, field supply). (Attach the pipe with glue, and fix it with the band (accessory).)
3. Perform insulation work on the drain pipe (O.D. ø32 mm [1-1/4 in] PVC TUBE PV-25) and on the socket (including elbow).
4. Check the drainage. (Refer to [Fig. 7.3.1])

- Attach the insulating material, and fix it with the band (accessory) to insulate the drain port.

[Fig. 7.2.2] (P.4)

- Ⓐ Indoor unit
- Ⓑ Tie band (accessory)
- Ⓒ Visible part
- Ⓓ Insertion margin
- Ⓔ Drain hose (accessory)
- Ⓕ Drain pipe (O.D.  $\phi 32$  mm [1-1/4 in] PVC TUBE, field supply)
- Ⓖ Insulating material (field supply)
- Ⓗ Tie band (accessory)

### 7.3. Confirming drain discharge

- Make sure that the drain-up mechanism operates normally for discharge and that there is no water leakage from the connections.
- Be sure to confirm the above in a period of heating operation.
- Be sure to confirm the above before ceiling work is done in the case of a new construction.

- Remove the water supply port cover on the same side as the indoor unit piping.
- Fill water into the feed water pump using a feed water tank. In filling, be sure to put the end of the pump or tank in a drain pan. (If the insertion is incomplete, water may flow over the machine.)
- Perform the test run in cooling mode, or connect the connector to the ON side of SWE on the Indoor controller board. (The drain pump and the fan are forced to operate without any remote controller operation.) Make sure using a transparent hose that drain is discharged.

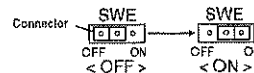

- After confirmation, cancel the test run mode, and turn off the main power. If the connector is connected to the ON side of SWE, disconnect it and connect it to the OFF side, and attach the water supply port cover into its original position.

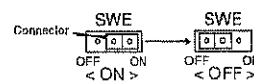

[Fig. 7.3.1] (P.5)

- Ⓐ Insert pump's end 2 to 4 cm [13/16 to 1-5/8 in].
- Ⓑ Remove the water supply port.
- Ⓒ About 2500 cc
- Ⓓ Water
- Ⓔ Filling port
- Ⓕ Screw

[Fig. 7.3.2] (P.5)

<Indoor controller board>

## 8. Duct work

- In connecting duct, insert canvas duct between unit and duct.
- Use incombustible material for duct parts.
- Provide full insulation to inlet duct flange and outlet duct to prevent condensation.
- Be sure to change the position of air filter to the position where it can be serviced.

[Fig. 8.0.1] (P.5)

<A> In case of rear inlet  
<B> In case of bottom inlet

- Ⓐ Duct
- Ⓑ Access door
- Ⓒ Ceiling surface
- Ⓓ Leave distance enough to prevent short cycle
- Ⓔ Air inlet
- Ⓕ Canvas duct
- Ⓖ Air outlet

- Procedure for changing the rear inlet to the bottom inlet.

[Fig. 8.0.2] (P.5)

- Ⓐ Filter
- Ⓑ Bottom plate

- Remove air filter. (First remove filter lock screw.)
- Remove the bottom plate.
- Fit the bottom plate to the rear of the body. [Fig. 8.0.3] (P.5)  
(Position of lug-holes on the plate are different from those for rear inlet.)

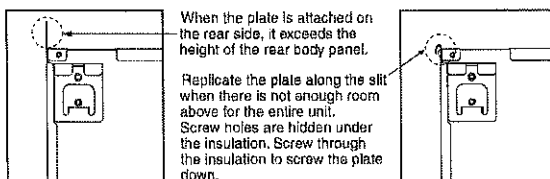

- Fit filter to the underside of the body.  
(Be careful of which side of the filter to fit.) [Fig. 8.0.4] (P.5)

[Fig. 8.0.4] (P.5)

- Ⓒ Nail for the bottom inlet
- Ⓓ Nail for the rear inlet

### ⚠ Caution:

- Inlet duct of 850 mm [33-1/2 in] or more should be constructed.  
To connect the air conditioner main body and the duct for potential equalization.

GB

# 9. Electrical wiring

## Precautions on electrical wiring

### ⚠ Warning:

Electrical work should be done by qualified electrical engineers in accordance with "Engineering Standards For Electrical Installation" and supplied installation manuals. Special circuits should also be used. If the power circuit lacks capacity or has an installation failure, it may cause a risk of electric shock or fire.

1. Be sure to install an earth leakage breaker to the power.
2. Install the unit to prevent that any of the control circuit cables (remote controller, transmission cables) is brought in direct contact with the power cable outside the unit.
3. Ensure that there is no slack on all wire connections.
4. Some cables (power, remote controller, transmission cables) above the ceiling may be bitten by mouses. Use as many metal pipes as possible to insert the cables into them for protection.

5. Never connect the power cable to leads for the transmission cables. Otherwise the cables would be broken.
6. Be sure to connect control cables to the indoor unit, remote controller, and the outdoor unit.
7. Put the unit to the ground on the outdoor unit side.
8. Select control cables from the conditions given in page 12.
9. Perform wiring in compliance with the safety regulations detailed in UL1995.

### ⚠ Caution:

- Be sure to put the unit to the ground on the outdoor unit side. Do not connect the earth cable to any gas pipe, water pipe, lightning rod, or telephone earth cable. Incomplete grounding may cause a risk of electric shock.
- If the supply cord is damaged, it must be replaced by the manufacturer, its service agent or similarly qualified persons in order to avoid a hazard.

## Transmission cable specifications

	Transmission cables	ME Remote controller cables	MA Remote controller cables
Type of cable	Shielding wire (2-core) CVVS, CPEVS or MVVS	Sheathed 2-core cable (CVV, shielded CVVS, CPEVS or MVVS)	Sheathed 2-core cable
Cable diameter	More than 1.25 mm <sup>2</sup>	0.3 ~ 1.25 mm <sup>2</sup> (0.75 ~ 1.25 mm <sup>2</sup> )*1	0.3 ~ 1.25 mm <sup>2</sup> (0.75 ~ 1.25 mm <sup>2</sup> )*1
Remarks	Max length: 200 m Maximum length of transmission lines for centralized control and indoor/ outdoor transmission lines (Maximum length via indoor units): 500 m MAX The maximum length of the wiring between power supply unit for transmission lines (on the transmission lines for centralized control) and each outdoor unit and system controller is 200 m.	When 10 m is exceeded, use cables with the same specification as transmission cables.	Max length: 200 m

\*1 Connected with simple remote controller.

CVVS, MVVS: PVC insulated PVC jacketed shielded control cable  
CPEVS: PE insulated PVC jacketed shielded communication cable  
CVV: PVC insulated PVC sheathed control cable

## 9.1. Power supply wiring

- Power supply cords of appliances shall not be lighter than design 245 IEC 57, 227 IEC 57, 245 IEC 53 or 227 IEC 53.
- A switch with at least 3 mm contact separation in each pole shall be provided by the Air conditioner installation.

[Fig. 9.1.1] (P.5)

- Ⓐ Ground-fault interrupter
- Ⓑ Local switch/Wiring breaker
- Ⓒ Indoor unit
- Ⓓ Pull box

Total operating current of the Indoor unit	Minimum wire thickness (mm <sup>2</sup> )			Ground-fault interrupter *1	Local switch (A)		Breaker for wiring (A) (Non-fuse breaker)
	Main cable	Branch	Ground		Capacity	Fuse	
F0 = 16 A or less *2	1.5	1.5	1.5	20 A current sensitivity *3	16	16	20
F0 = 25 A or less *2	2.5	2.5	2.5	30 A current sensitivity *3	25	25	30
F0 = 32 A or less *2	4.0	4.0	4.0	40 A current sensitivity *3	32	32	40

Apply to IEC61000-3-3 about Max. Permissive System Impedance.

\*1 The Ground-fault interrupter should support Inverter circuit.

The Ground-fault interrupter should combine using of local switch or wiring breaker.

\*2 Please take the larger of F1 or F2 as the value for F0.

F1 = Total operating maximum current of the indoor units × 1.2

F2 = {V1 × (Quantity of Type1)/C} + {V1 × (Quantity of Type2)/C} + {V1 × (Quantity of Type3)/C} + {V1 × (Quantity of Others)/C}

Indoor unit	V1	V2
PEFY-NMAU	38	1.6

C : Multiple of tripping current at tripping time 0.01s

Please pick up "C" from the tripping characteristic of the breaker.

<Example of "F2" calculation>

\*Condition PEFY-NMAU × 3, C = 8 (refer to right sample chart)

F2 = 38 × 3/8

= 14.25

→ 16 A breaker (Tripping current = 8 × 16 A at 0.01s)

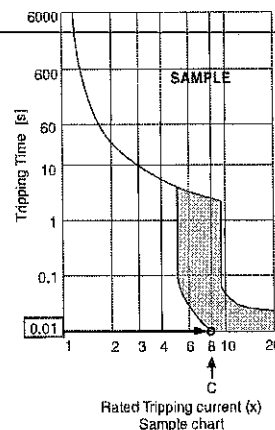

\*3 Current sensitivity is calculated using the following formula.

$$G1 = (V2 \times \text{Quantity of Type1}) + (V2 \times \text{Quantity of Type2}) + (V2 \times \text{Quantity of Type3}) + (V2 \times \text{Quantity of Others}) + (V3 \times \text{Wire length [km]})$$

G1	Current sensitivity
30 or less	30 mA 0.1 sec or less
100 or less	100 mA 0.1 sec or less

Wire thickness	V3
1.5 mm <sup>2</sup>	48
2.5 mm <sup>2</sup>	56
4.0 mm <sup>2</sup>	66

**⚠ Caution:**

Do not use anything other than the correct capacity breaker and fuse. Using fuse, wire or copper wire with too large capacity may cause a risk of malfunction or fire.

## 9.2. Connecting remote controller, indoor and outdoor transmission cables

- Connect indoor unit TB5 and outdoor unit TB3. (Non-polarized 2-wire)  
The "S" on indoor unit TB5 is a shielding wire connection. For specifications about the connecting cables, refer to the outdoor unit installation manual.
- Install a remote controller following the manual supplied with the remote controller.
- Connect the "1" and "2" on indoor unit TB15 to a MA remote controller. (Non-polarized 2-wire)
- Connect the "M1" and "M2" on indoor unit TB5 to a M-NET remote controller. (Non-polarized 2-wire)
- Connect the remote controller's transmission cable within 10 m [32 ft] using a 0.75 mm<sup>2</sup> [AWG18] core cable. If the distance is more than 10 m [32 ft], use a 1.25 mm<sup>2</sup> [AWG16] junction cable.

[Fig. 9.2.1] (P.5) MA Remote controller

[Fig. 9.2.2] (P.5) M-NET Remote controller

- Ⓐ Terminal block for indoor transmission cable
- Ⓑ Terminal block for outdoor transmission cable
- Ⓒ Remote controller

- DC 9 to 13 V between 1 and 2 (MA remote controller)
- DC 24 to 30 V between M1 and M2 (M-NET remote controller)

[Fig. 9.2.3] (P.6) MA Remote controller

[Fig. 9.2.4] (P.6) M-NET Remote controller

- Ⓐ Non-polarized
- Ⓑ TB15
- Ⓒ Remote Controller
- Ⓓ TB5

- The MA remote controller and the M-NET remote controller cannot be used at the same time or interchangeably.

**⚠ Caution:**

Install wiring so that it is not tight and under tension. Wiring under tension may break, or overheat and burn.

## 9.3. Connecting electrical connections

Please identify the model name of the operation manual attached on the terminal box cover with that shown on the rating name plate.

1. Remove the screw (1pc) holding the cover to dismount the cover.

[Fig. 9.3.1] (P.6)

- Ⓐ Screw holding cover (1pc)
- Ⓑ Cover

2. Open knockout holes  
(Recommend to use a screwdriver or the like for this work.)

[Fig. 9.3.2] (P.6)

- Ⓒ Terminal box
- Ⓓ Knockout hole
- Ⓔ Remove

3. Fix power source wiring to terminal box by using buffer bushing for tensile force. (PG connection or the like.) Connect transmission wiring to transmission terminal block through the knockout hole of terminal box using ordinary bushing.

[Fig. 9.3.3] (P.6)

- Ⓔ Use PG bushing to keep the weight of the cable and external force from being applied to the power supply terminal connector. Use a cable tie to secure the cable.
- Ⓕ Power source wiring
- Ⓖ Use ordinary bushing
- Ⓗ Transmission wiring
- Ⓖ Conduit
- Ⓖ Side frame
- Ⓖ Knockout hole (for power source wiring)
- Ⓖ Washer (round) (accessory)

4. Connect the power source, Earth, transmission and remote controller wiring. The dismounting of the terminal box is not needed.

[Fig. 9.3.4] (P.6)

- Ⓖ Terminal block for power source
- Ⓖ Terminal block for indoor transmission
- Ⓖ Terminal block for remote controller

[Shield wire connection]

[Fig. 9.3.5] (P.6)

- Ⓐ Terminal block
- Ⓖ Round terminal
- Ⓒ Shield wire

- Ⓓ The earth wire from two cables are connected together to the S terminal. (Dead-end connection)
- Ⓔ Insulation tape. (To keep the earth wire of the shielded cable from coming in contact with the transmission terminal)

5. After wiring is complete, make sure again that there is no slack on the connections, and attach the cover onto the terminal box in the reverse order of removal.

**Notes:**

- Do not pinch the cables or wires when attaching the terminal box cover. Doing so may cause a risk of disconnection.
- When accommodating the terminal box, make sure that the connectors on the box side are not removed. If removed, it cannot operate normally.

## 9.4. External I/O specifications

**⚠ Caution:**

1. Wiring should be covered by insulation tube with supplementary insulation.
2. Use relays or switches with IEC or equivalent standard.
3. The electric strength between accessible parts and control circuit should have 2750 V or more.

GB

## 9.5. Selecting the external static pressure

As the factory setting is for use under an external static pressure of 0.20 in. WG (50 Pa), no switch operation is needed when using under the standard condition.

External static pressure	Switch operation
0.14 in. WG (35 Pa)	
0.20 in. WG (50 Pa)	
0.28 in. WG (70 Pa)	
0.4 in. WG (100 Pa)	
0.60 in. WG (150 Pa)	

[Fig. 9.5.1] (P.6)  
<Indoor controller board>

## 9.7. Sensing room temperature with the built-in sensor in a remote controller

If you want to sense room temperature with the built-in sensor in a remote controller, set SW1-1 on the control board to "ON". The setting of SW1-7 and SW1-8 as necessary also makes it possible to adjust the air flow at a time when the heating thermometer is OFF.

## 9.8. Changing the power voltage setting

(Be sure to operate with the main power turned OFF.)

[Fig. 9.5.1] (P.6)

Please set the switch SW5 according to the power voltage.

- Set SW5 to 240V side when the power supply is 230 volts.
- When the power supply is 208 volts, set SW5 to 220V side.

## 9.6. Setting addresses

(Be sure to operate with the main power turned OFF.)

[Fig. 9.5.1] (P.6)

<Indoor controller board>

- There are two types of rotary switch setting available: setting addresses 1 to 9 and over 10, and setting branch numbers.
  - ① How to set addresses  
Example: If Address is "3", remain SW12 (for over 10) at "0", and match SW11 (for 1 to 9) with "3".
  - ② How to set branch numbers SW14 (Series R2 only)  
The branch number assigned to each indoor unit is the port number of the BC controller to which the indoor unit is connected. Leave it to "0" on the non-R2 series of units.
- The rotary switches are all set to "0" when shipped from the factory. These switches can be used to set unit addresses and branch numbers at will.
- The determination of indoor unit addresses varies with the system at site. Set them referring to the Data Book.

## 9.9. Electrical characteristics

Symbols : MCA : Max. Circuit Amps (= 1.25 × FLA) FLA : Full Load Amps  
IFM : Indoor Fan Motor Output : Fan motor rated output

Model	Indoor Unit			IFM		
	Hz	Volts	Voltage range	MCA (A)	Output (kW)	FLA (A)
PEFY-P06NMAU-E3	60 Hz	208 / 230 V	188 to 253 V	1.05 / 1.05	0.085 / 0.085	0.84 / 0.84
PEFY-P08NMAU-E3				1.05 / 1.05	0.085 / 0.085	0.84 / 0.84
PEFY-P12NMAU-E3				1.20 / 1.20	0.085 / 0.085	0.96 / 0.96
PEFY-P15NMAU-E3				1.45 / 1.45	0.085 / 0.085	1.16 / 1.16
PEFY-P18NMAU-E3				1.56 / 1.56	0.085 / 0.085	1.25 / 1.25
PEFY-P24NMAU-E3				2.73 / 2.73	0.121 / 0.121	2.18 / 2.18
PEFY-P27NMAU-E3				2.73 / 2.73	0.121 / 0.121	2.18 / 2.18
PEFY-P30NMAU-E3				2.73 / 2.73	0.121 / 0.121	2.18 / 2.18
PEFY-P36NMAU-E3				3.32 / 3.32	0.244 / 0.244	2.66 / 2.66
PEFY-P48NMAU-E3				3.41 / 3.41	0.244 / 0.244	2.73 / 2.73
PEFY-P54NMAU-E3				3.31 / 3.31	0.244 / 0.244	2.65 / 2.65

---

This product is designed and intended for use in the residential,  
commercial and light-industrial environment.

Please be sure to put the contact address/telephone number on  
this manual before handing it to the customer.

--

**MITSUBISHI ELECTRIC CORPORATION**

HEAD OFFICE: TOKYO BLDG., 2-7-3. MARUNOUCHI, CHIYODA-KU, TOKYO 100-8310, JAPAN

**Acknowledgment of Code Compliance Responsibility- Fast Track Project**



I, \_\_\_\_\_ am the owner or duly **authorized owner's agent** of the property listed below  
Print Legal Name

Physical Address

I am seeking a permit for the construction or installation of:

Proposed Project Description

I understand that the permits obtained pursuant to this acknowledgement of code compliance responsibility will be in my name and that I am acting as the **general contractor** for this project. I accept full responsibility for the work performed.

I am submitting for a permit authorized by the **State of Maine Uniform Building and Energy Code (MUBEC), Fuel Board Laws and Rules and all locally adopted codes and standards applying to Plumbing, Electrical, Fire Prevention and Protection in anticipation of having it approved or approved with conditions.** I have read the following statement and understand that **failure to comply with all conditions once construction is begun may necessitate an immediate work stoppage until such time as compliance with the stipulated conditions is attained.** I certify that I have made a diligent inquiry regarding the need for concurrent state or federal permits to engage in the work requested under this building permit, and no such permits are required or I will have obtained the required permits prior to issuance of this permit. I understand that the granting of this permit shall not be construed as satisfying the requirements of other applicable Federal, State or Local laws or regulations, including City of Portland historic preservation requirements, if applicable. I understand and agree that this permit does not authorize the violation of regulations.

In addition, I understand and agree that this building permit does not authorize the violation of the **12 M.R.S. § 12801 et seq. - Endangered Species.**

I certify under penalty of perjury and under the laws of the State of Maine the foregoing is true and correct. I further certify that all easements, deed restrictions, or other encumbrances restricting the use of the property are shown on the site plans submitted with this application.

I hereby apply for a permit as a \_\_\_\_\_ of the below listed property and by so doing will assume  
Owner or Owner's Agent  
responsibility for compliance with all applicable codes, bylaws, rules and regulations.

*I further understand that it is my responsibility to schedule inspections of the work as required and that the City's inspections will, at that time, check the work for code compliance. The City's inspectors may require modifications to the work completed if it does not meet applicable codes. \_\_\_\_\_ INITIAL HERE*

Sign Here: \_\_\_\_\_  
Owner or Owner's Authorized Agent

Date: \_\_\_\_\_

PLEASE ALSO FILL OUT AND SIGN SECOND PAGE



# Acknowledgment of Code Compliance Responsibility- Fast Track Project

OFFICE USE ONLY



PERMIT # \_\_\_\_\_

CBL # \_\_\_\_\_

THIS PROJECT IS ELIGIBLE FOR FAST TRACK PERMITTING BECAUSE IT IS IN THE FOLLOWING CATEGORY / CATEGORIES (CHECK ALL THAT APPLY):

- One/Two Family Swimming Pools, Spas or Hot Tubs
- One/Two Family Decks, Stairs and Porches (attached or detached) First Floor Only
- One/Two Family Detached One Story Accessory Structures (garages, sheds, etc.) not to exceed 600sq ft with no habitable space
- Home Occupations (excluding day cares )
- One/Two Family Renovation/Rehabilitation (within the existing shell)
- Attached One /Two Family Garages /Additions/Dormers bearing the seal of a licensed design professional
- New *Sprinklered* One and Two Family Homes (bearing the seal of a licensed design professional stating code compliance) – **MUST STILL RECEIVE LEVEL 1 SITE PLAN APPROVAL FROM PLANNING**
- One/Two Family HVAC (including boilers, furnaces, heating appliances, pellet and wood stoves)
- Interior office renovations with no change of use (no expansions; no site work; no load bearing structural changes are eligible) bearing the seal of a licensed design professional stating code compliance
- Interior Demolition with no load bearing demolition
- Amendments to existing permits
- Commercial HVAC systems (with structural and mechanical plans bearing the seal of a licensed design professional stating code compliance)
- Commercial HVAC for Boilers/Furnaces/Heating Appliances
- Commercial Signs or Awnings
- Exterior Propane Tanks
- Residential or Commercial Subsurface Waste Water Systems (No Rule Variance Only)
- Renewal of Outdoor Dining Areas
- Temporary Outdoor Tents and stages under 750 sq ft per tent or stage

---

- Fire Suppression Systems (Both non-water and water based installations)
- Fences over 6'-0" in height
- Site work only
- Retaining walls over 4ft in height with stamped plans (or approval from inspection staff)

I understand that if the property is located in a historic district this application will also be reviewed by Historic Preservation. I further understand that the Building Inspections Division reserves the right to deny a fast track eligible project.

Sign Here: \_\_\_\_\_  
Owner or Owner's Authorized Agent

Date: \_\_\_\_\_