

Consultant:

Revision:

- 1 | ADDENDUM 1 | 2015.10.19
- 2 | REVISION | 2015.11.25

Architect of Record:



Drawn: ECI

Checked: PRR

Scale: AS NOTED

Key Plan:

Project Name:

LORING HOUSE

1125 Brighton Avenue
 Portland, ME 04102

Sheet Name:

Slate Roof Details

Project Number:

14165

Issue Date:

November 25, 2015

Sheet Number:

A5.52

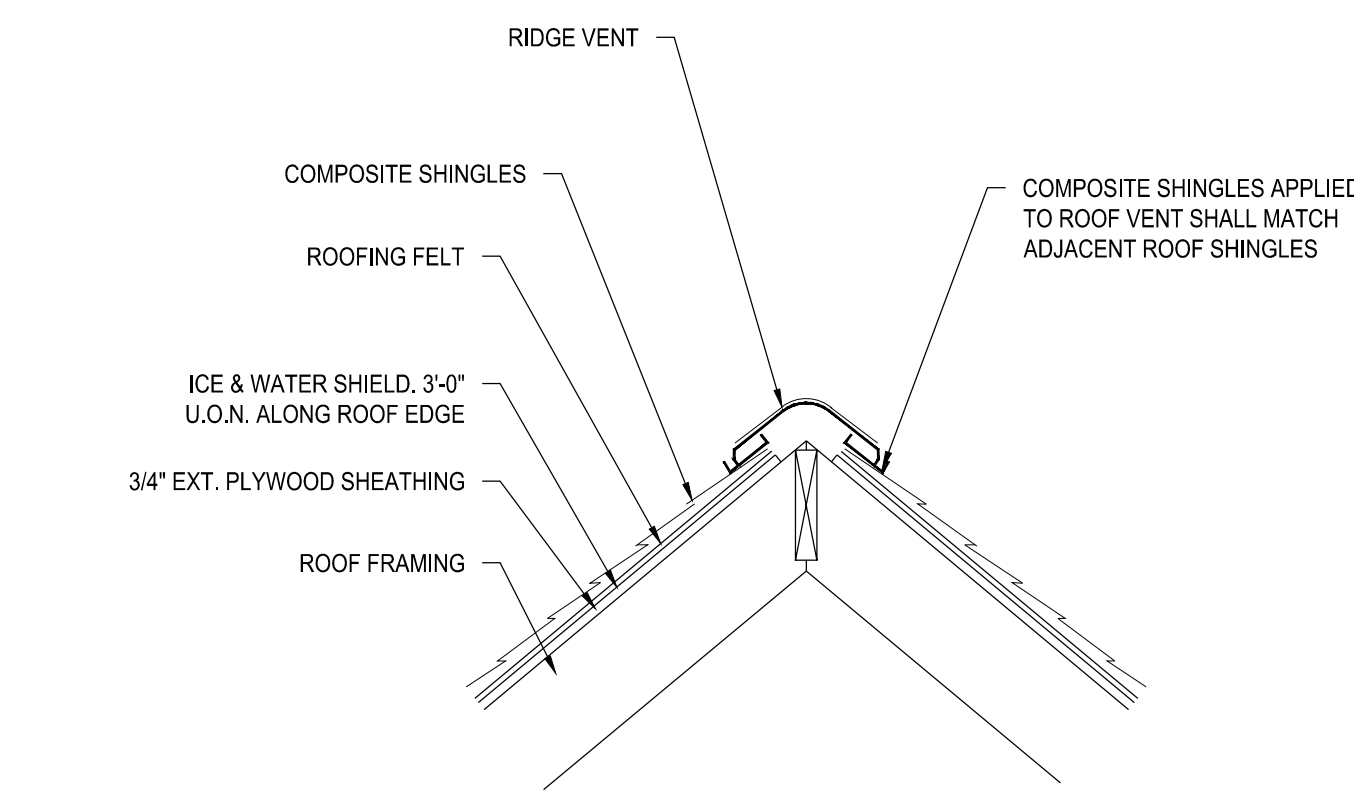

43 TYPICAL RIDGE VENT
 SCALE: NOT TO SCALE

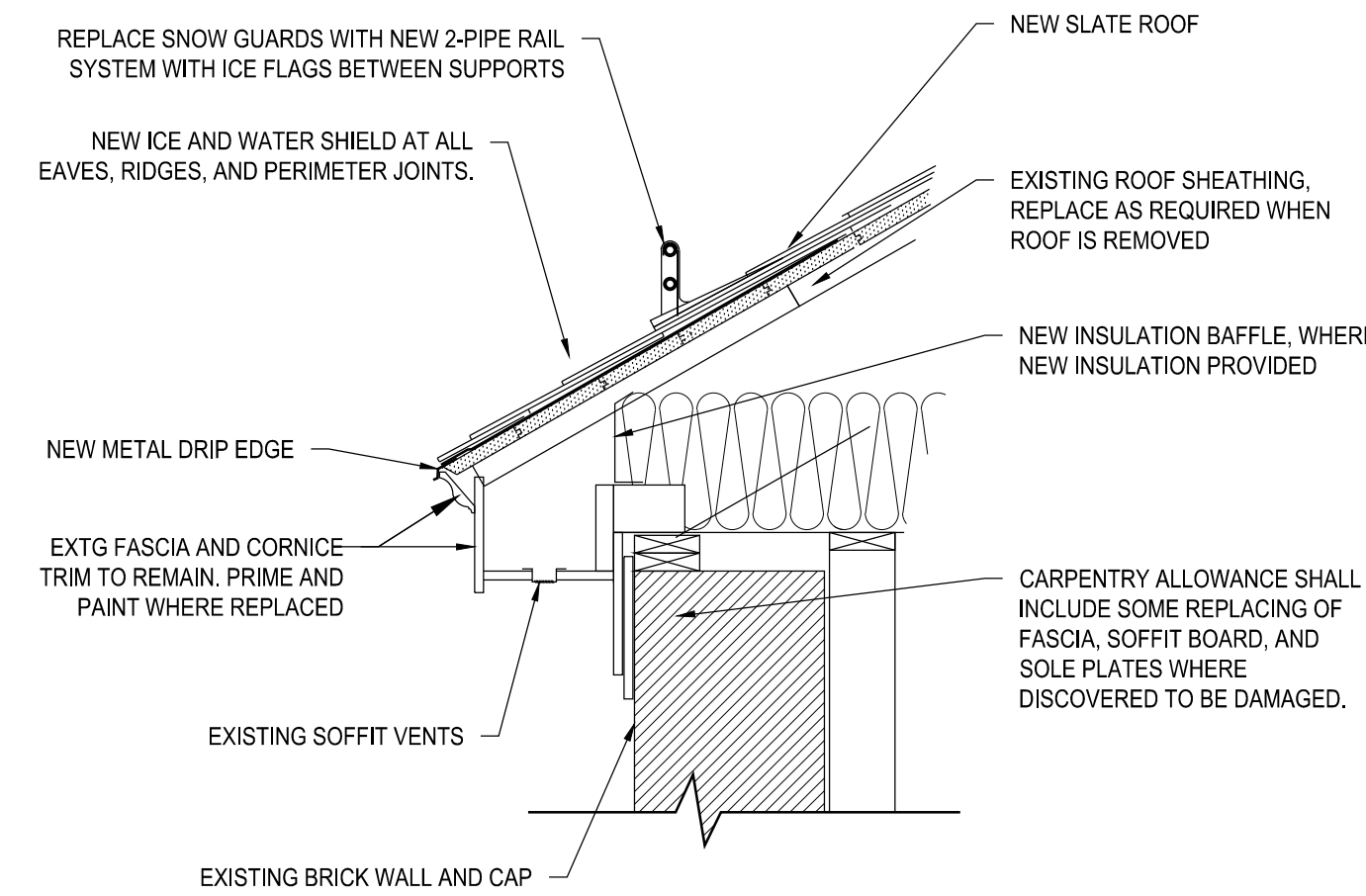

33 TYPICAL EAVE DETAIL
 SCALE: NOT TO SCALE

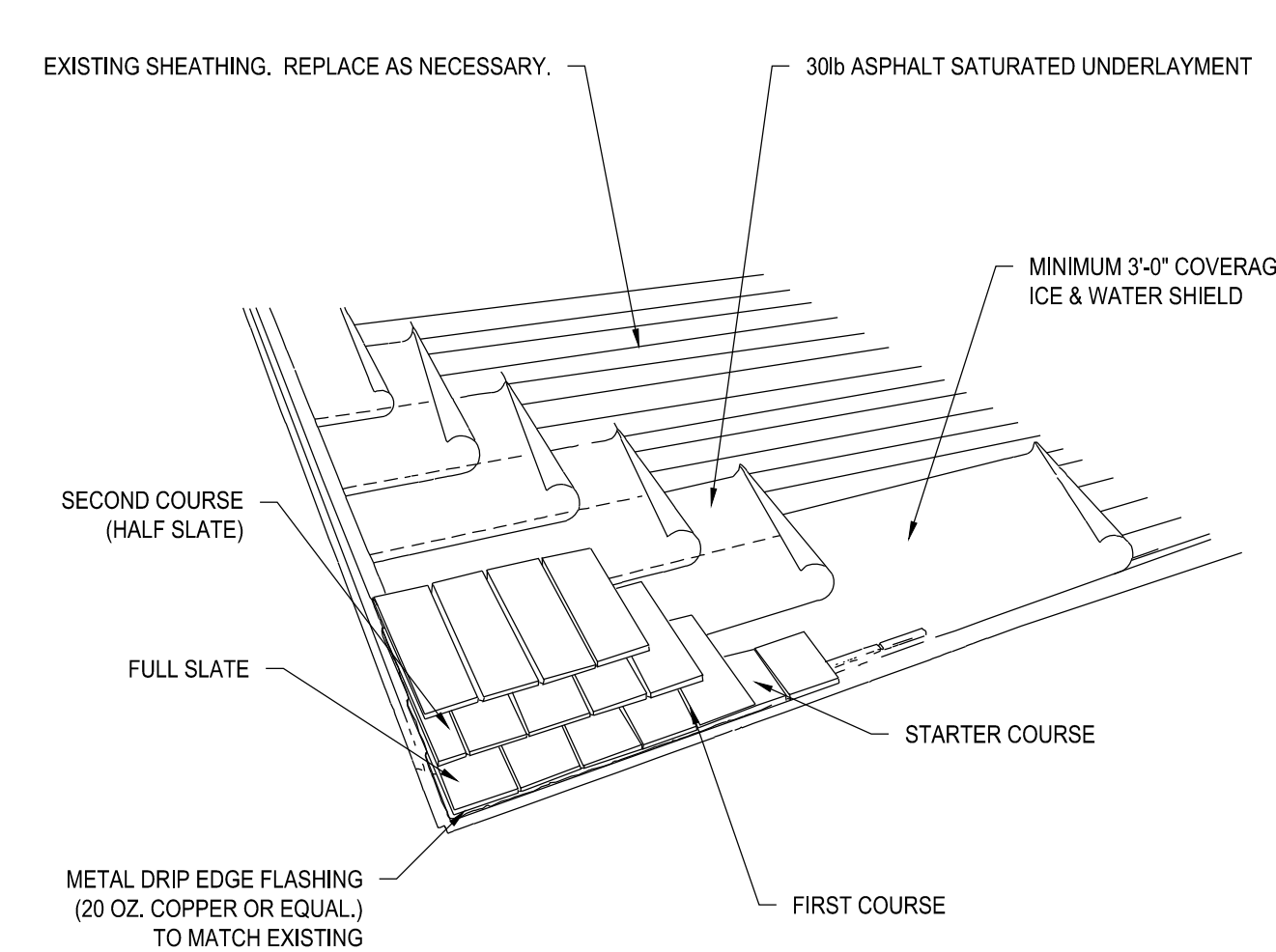

23 SLATE DETAIL AT EAVES
 SCALE: NOT TO SCALE

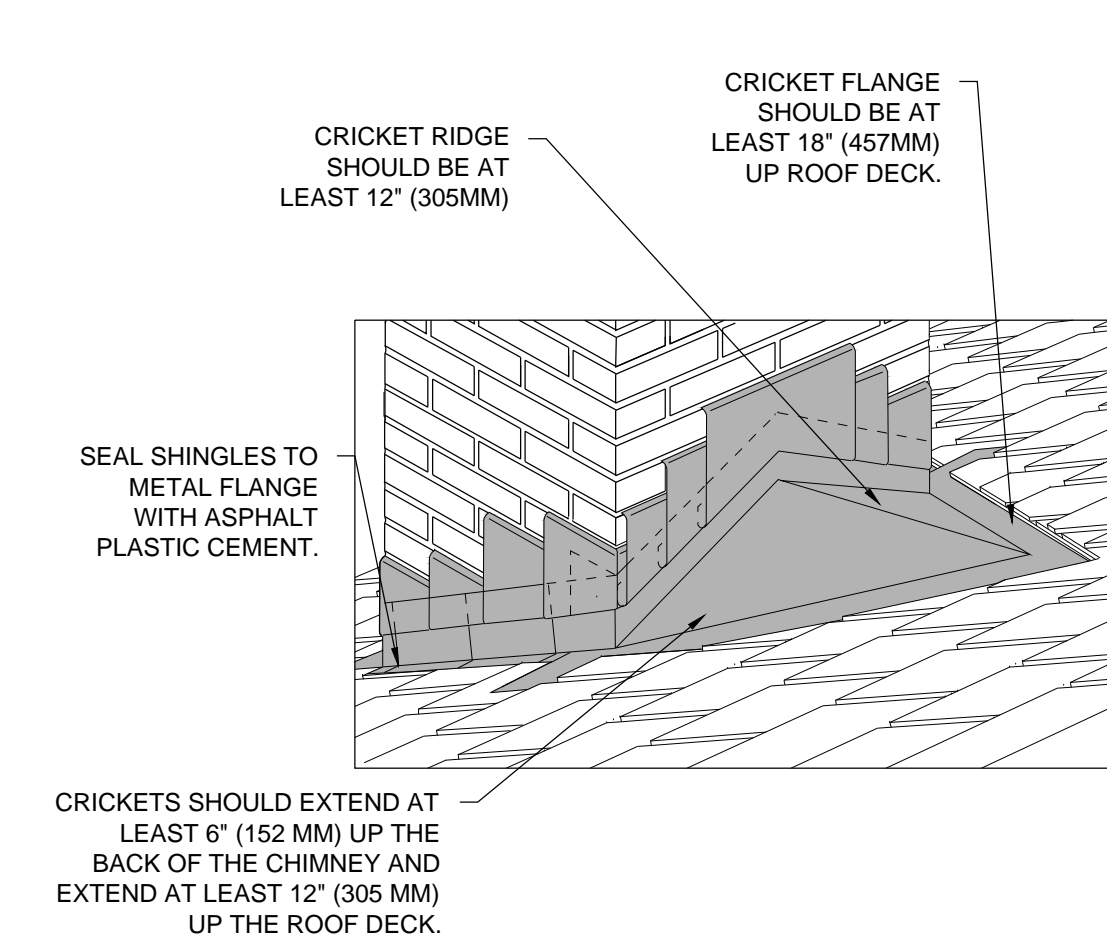

13 CHIMNEY CRICKET DETAIL
 SCALE: NOT TO SCALE

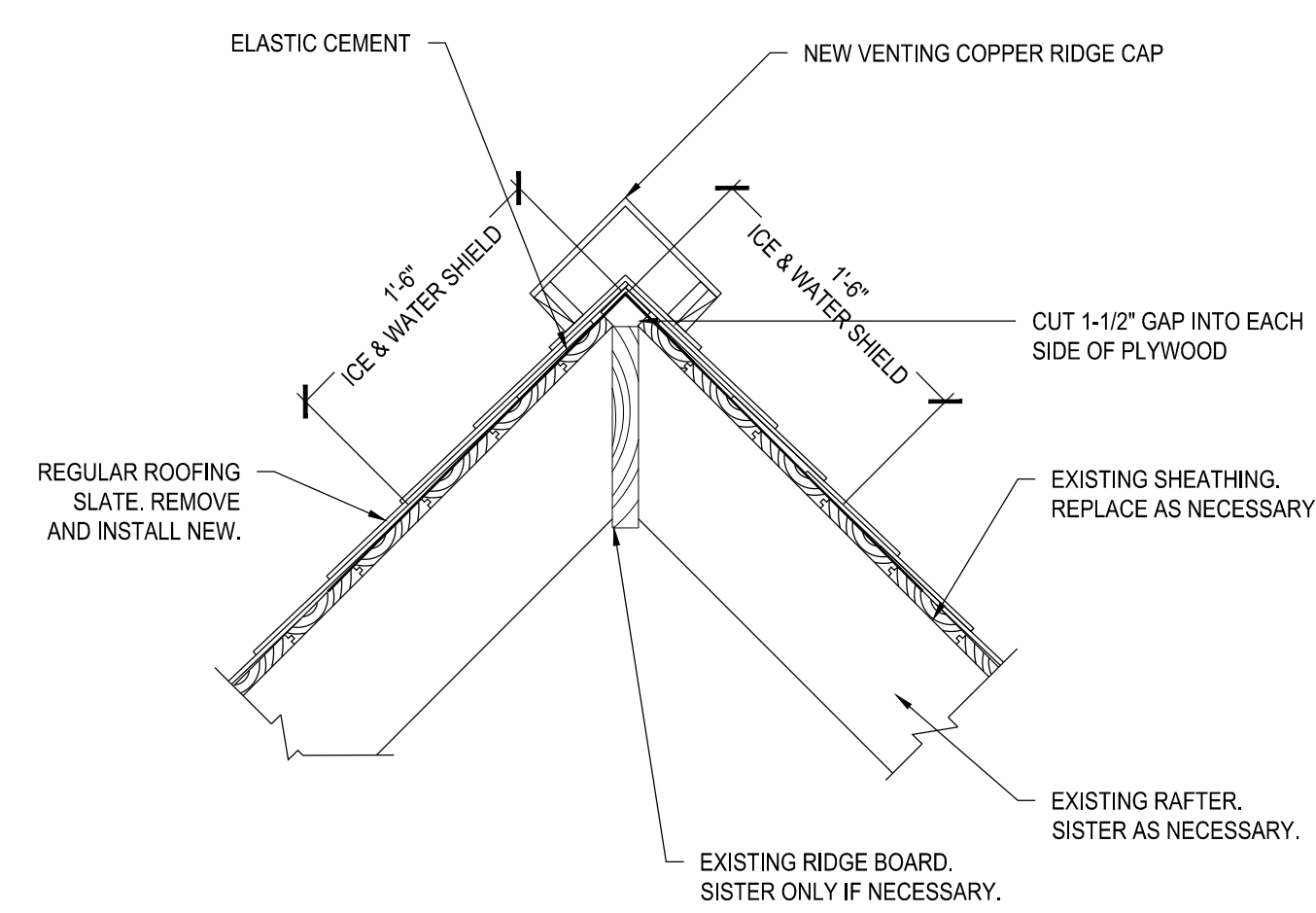

42 SLATE DETAIL AT RIDGE
 SCALE: NOT TO SCALE

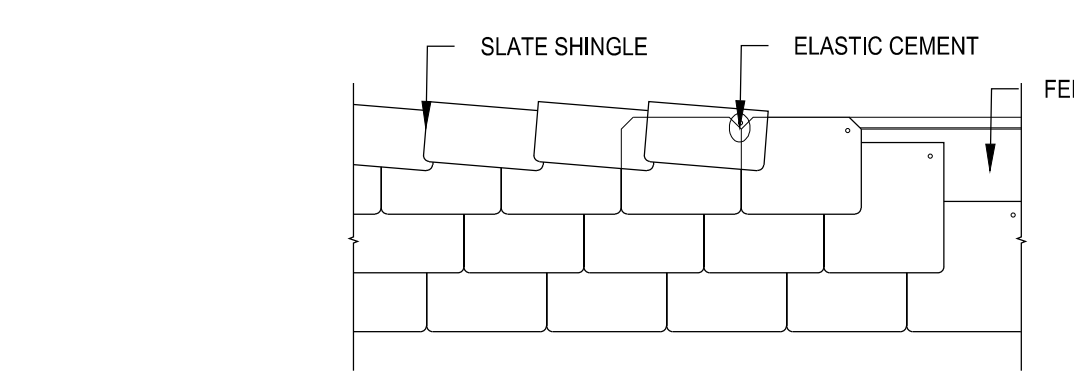

32 SLATE RIDGE
 SCALE: NOT TO SCALE

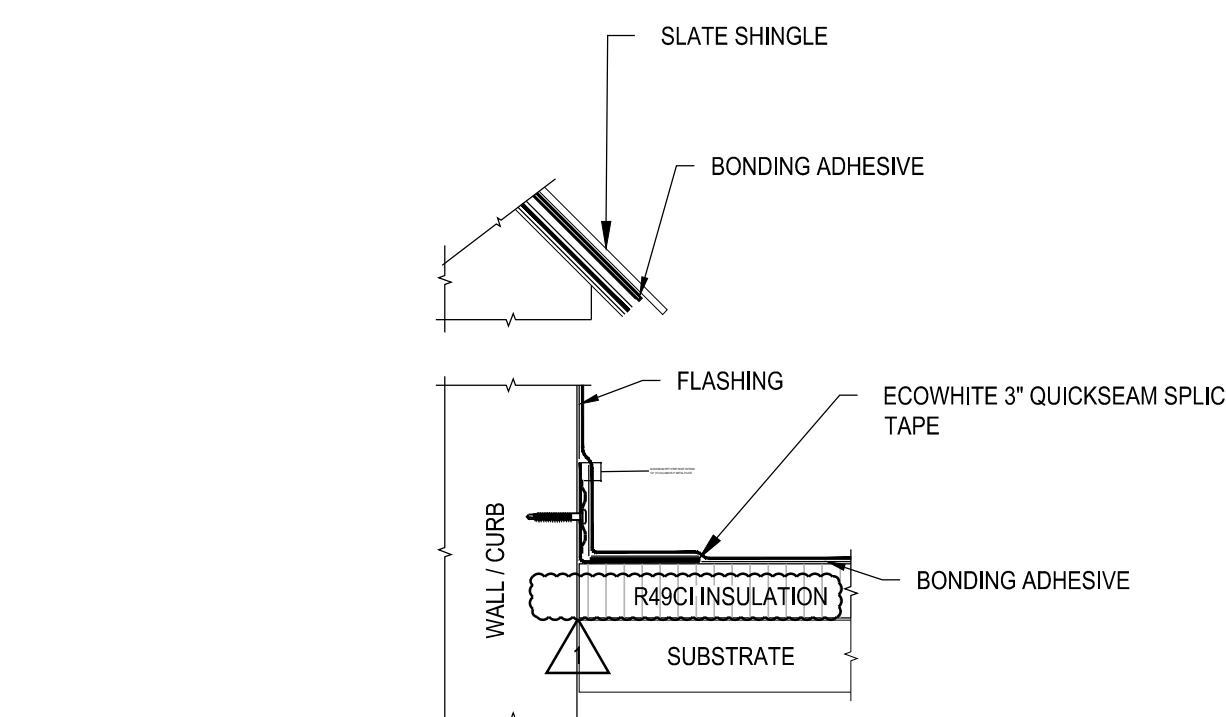

22 BASE TIE-IN AT SLATE ROOF
 SCALE: NOT TO SCALE

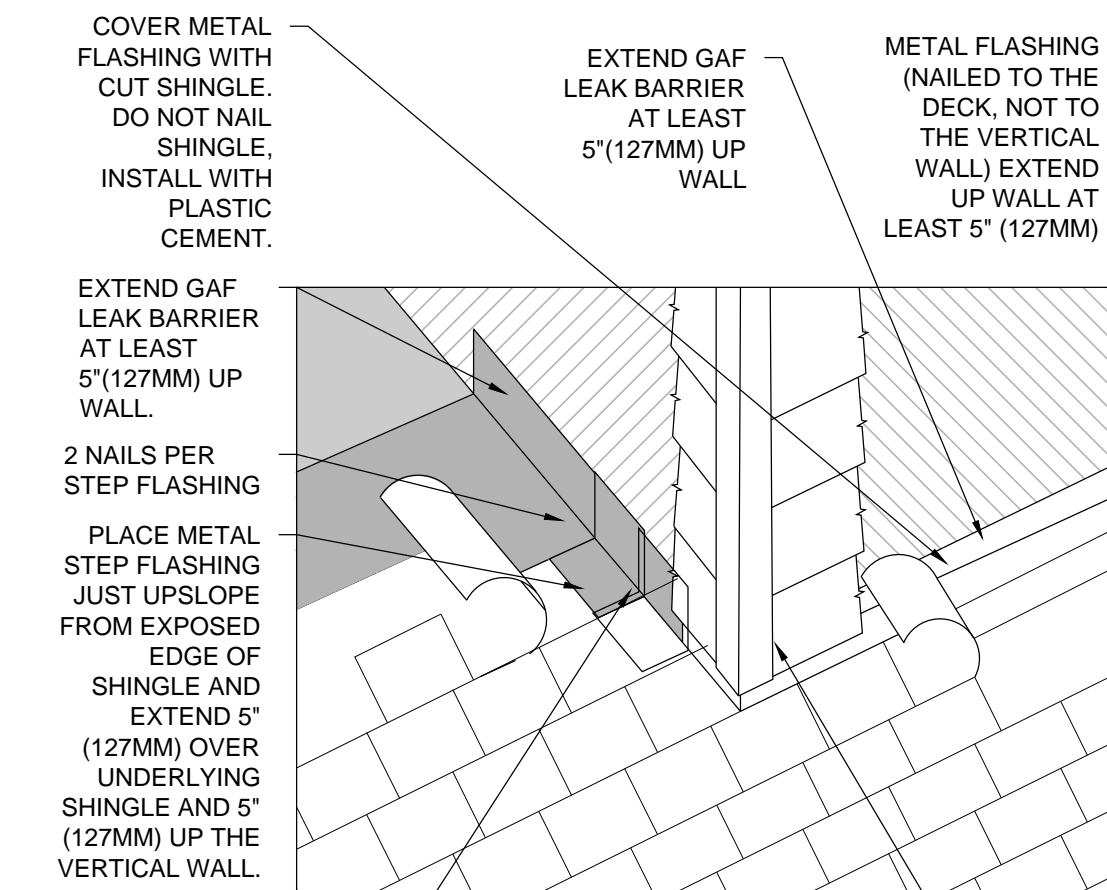

12 WALL FLASHING DETAIL
 SCALE: NOT TO SCALE

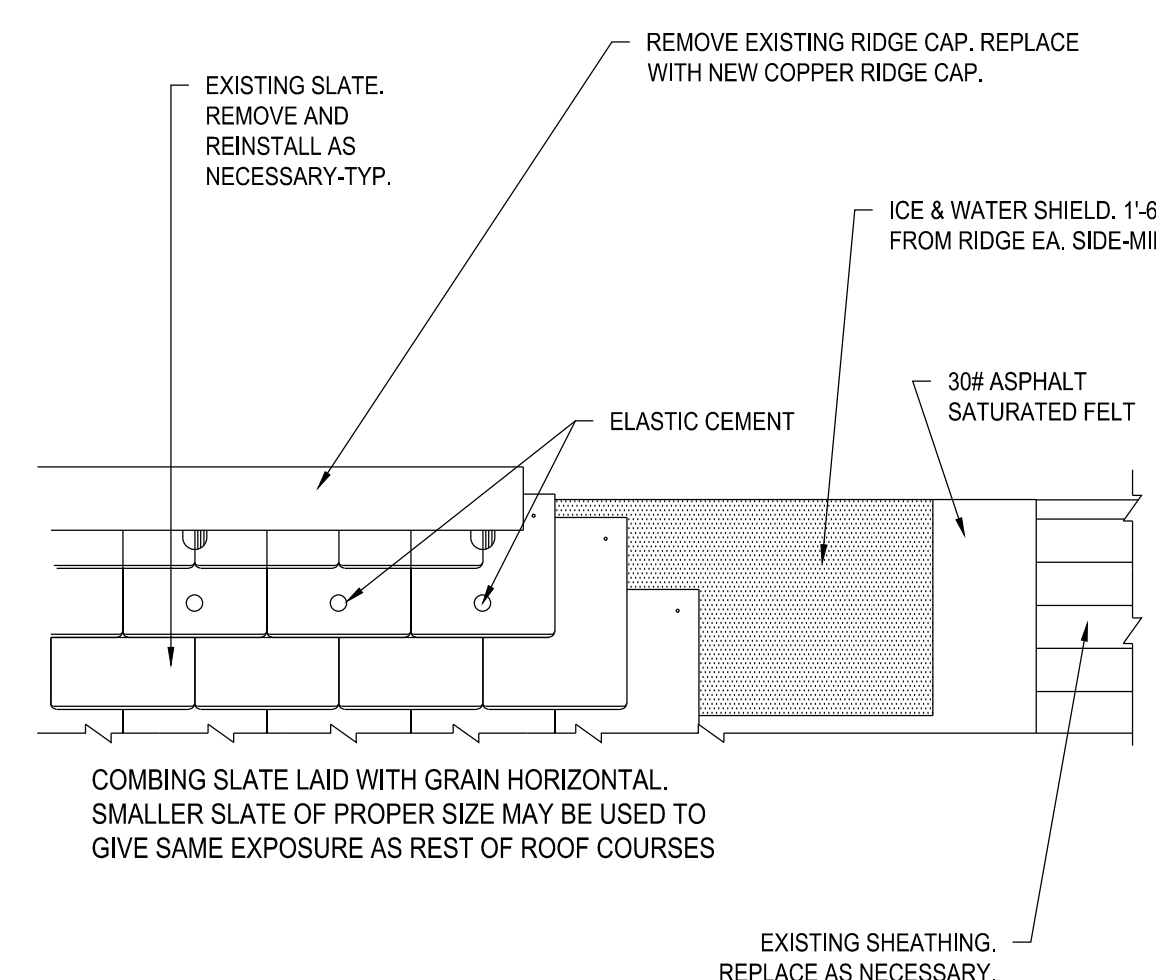

51 RIDGE DETAIL
 SCALE: NOT TO SCALE

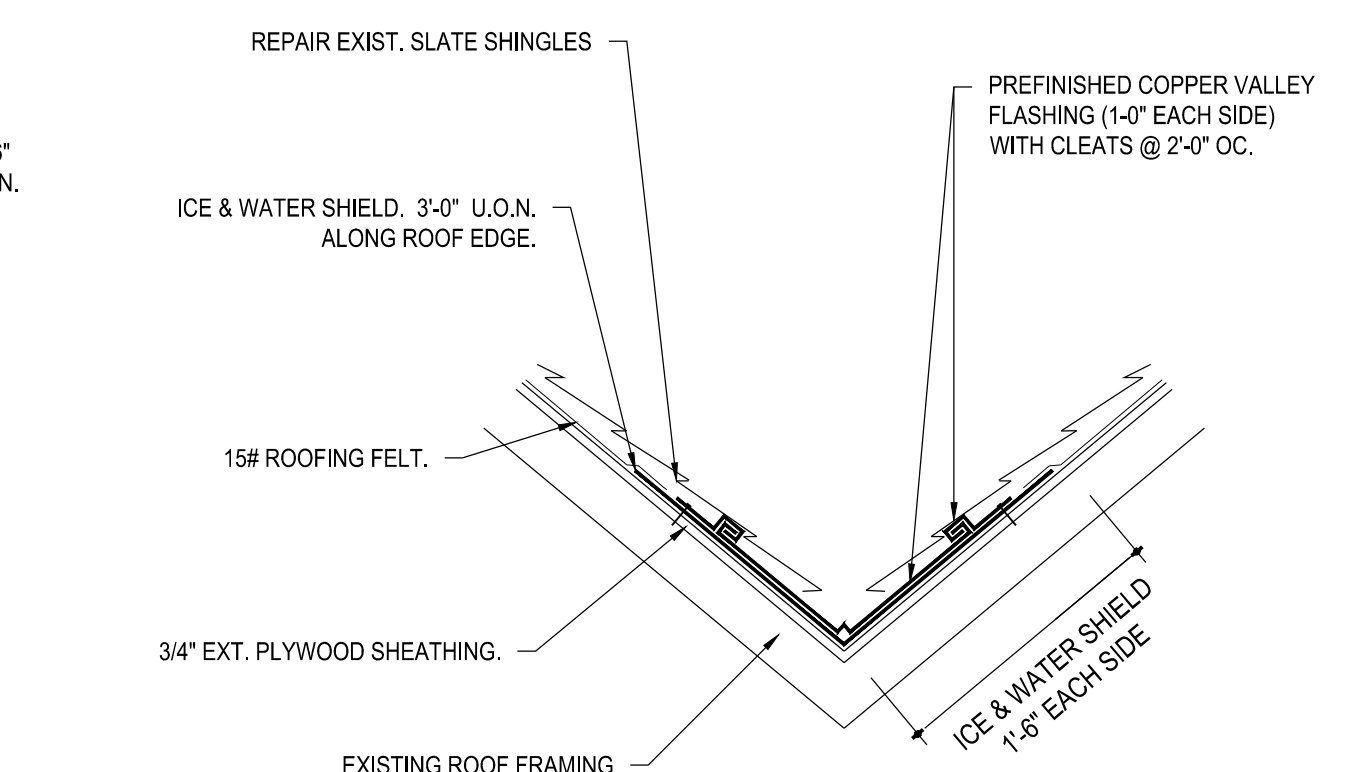

41 TYPICAL VALLEY FLASHING
 SCALE: NOT TO SCALE

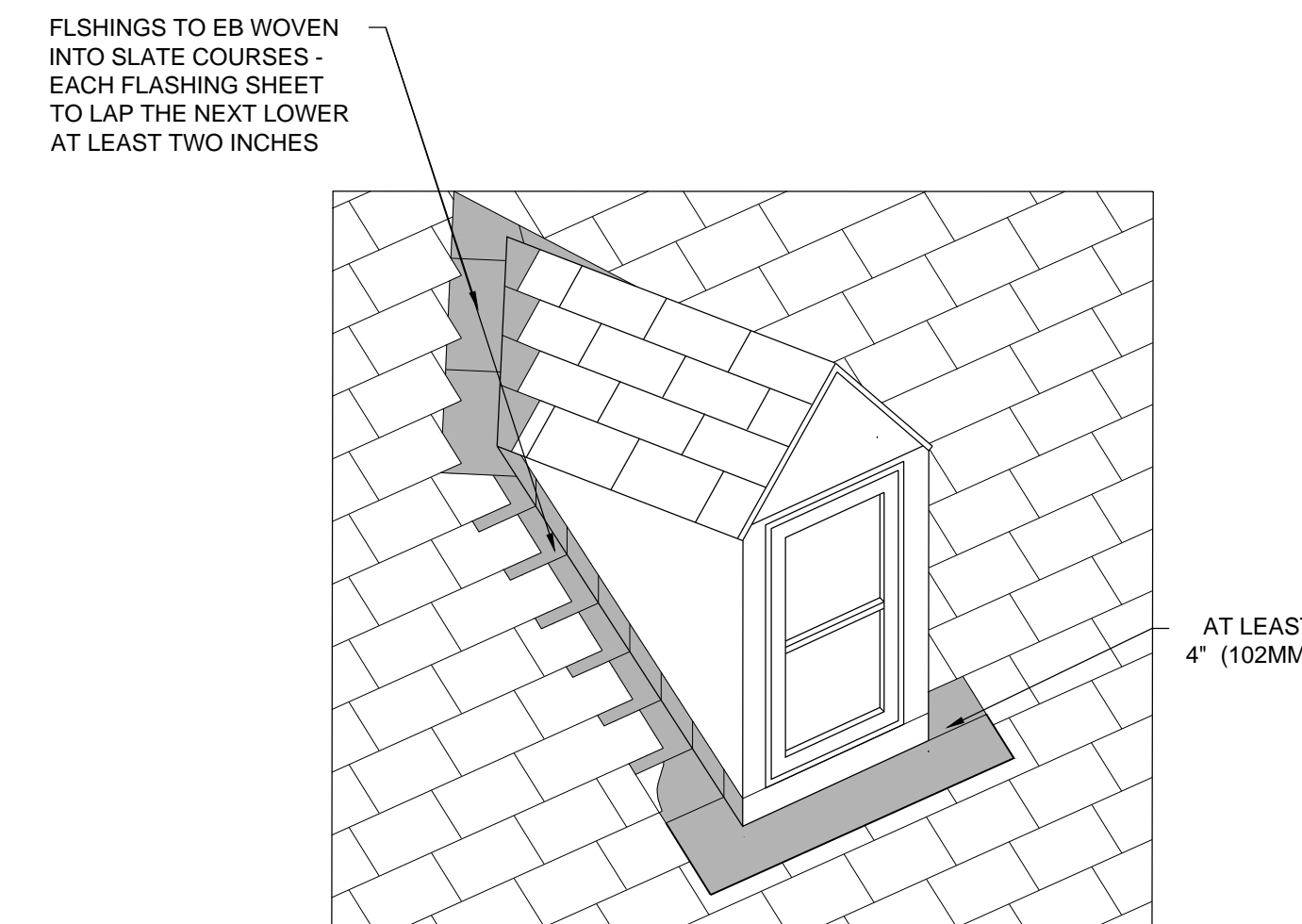

31 BUILT IN BASE FLASHING FOR DORMER WINDOW ON SLATE ROOF
 SCALE: NOT TO SCALE

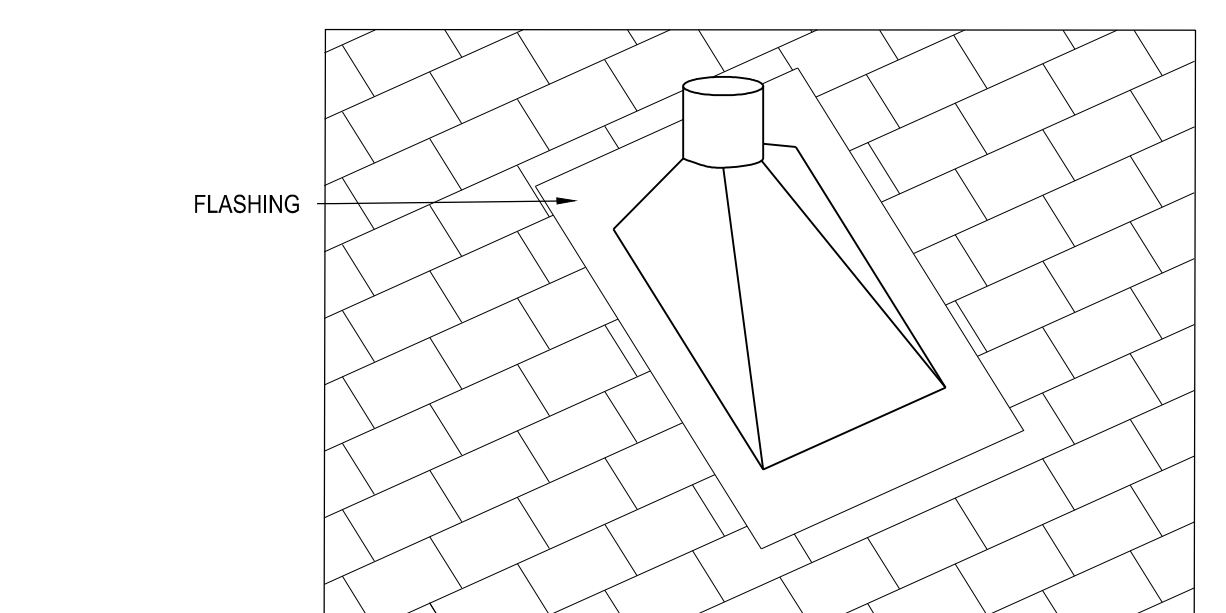

21 FLASHING FOR VENTILATION ON SLOPE OF SLATE ROOF
 SCALE: NOT TO SCALE

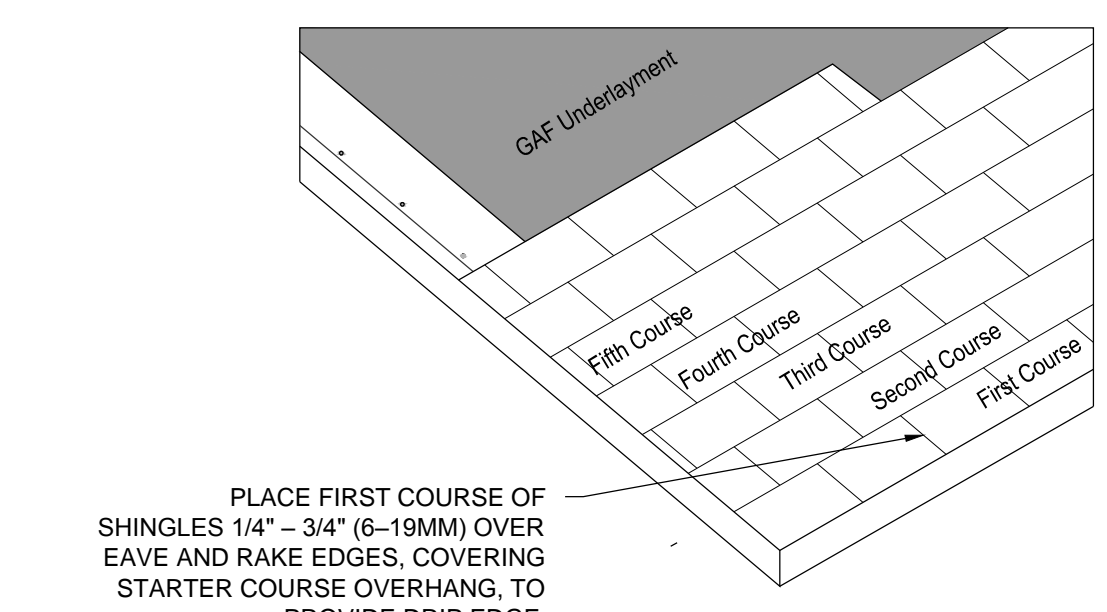

11 SHINGLE INSTALLATION DETAIL
 SCALE: NOT TO SCALE

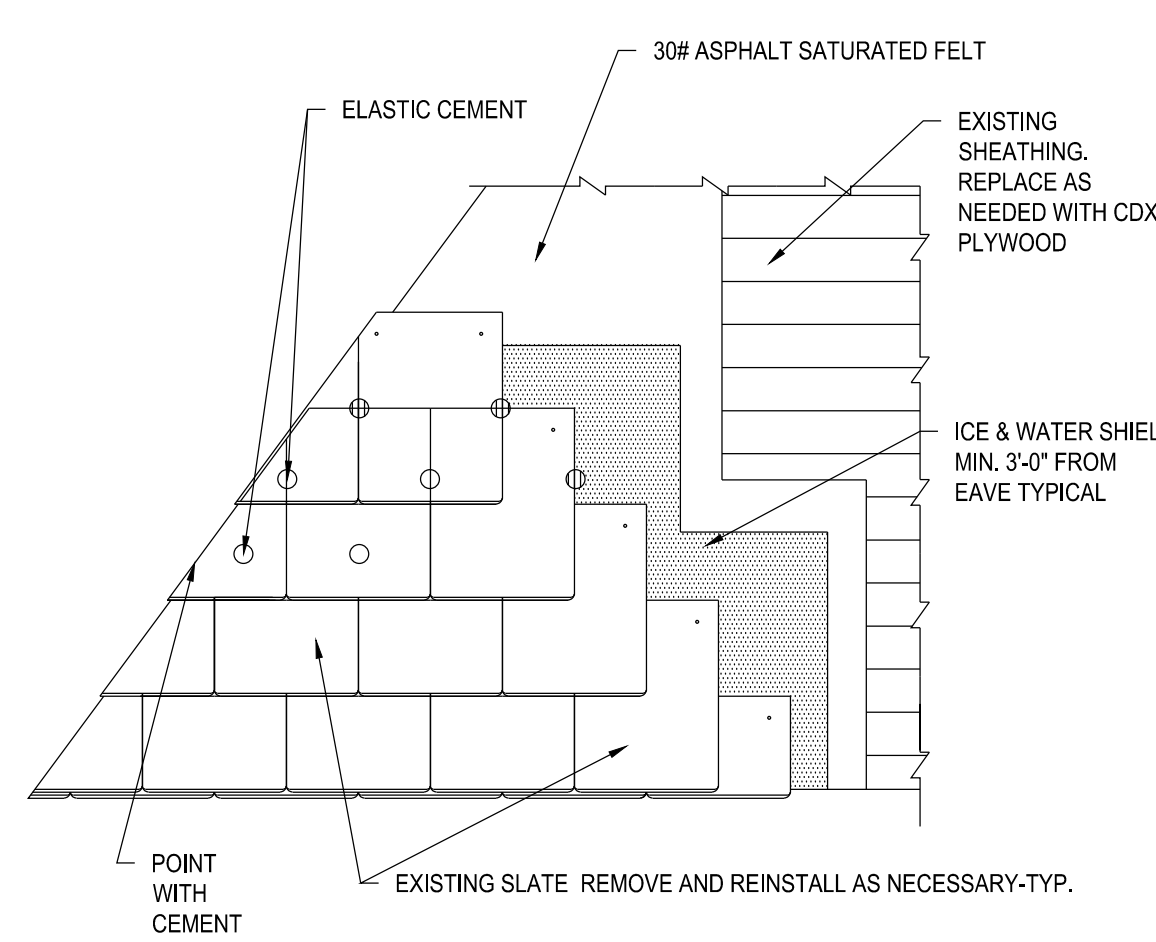

50 MITRED HIP
 SCALE: NOT TO SCALE

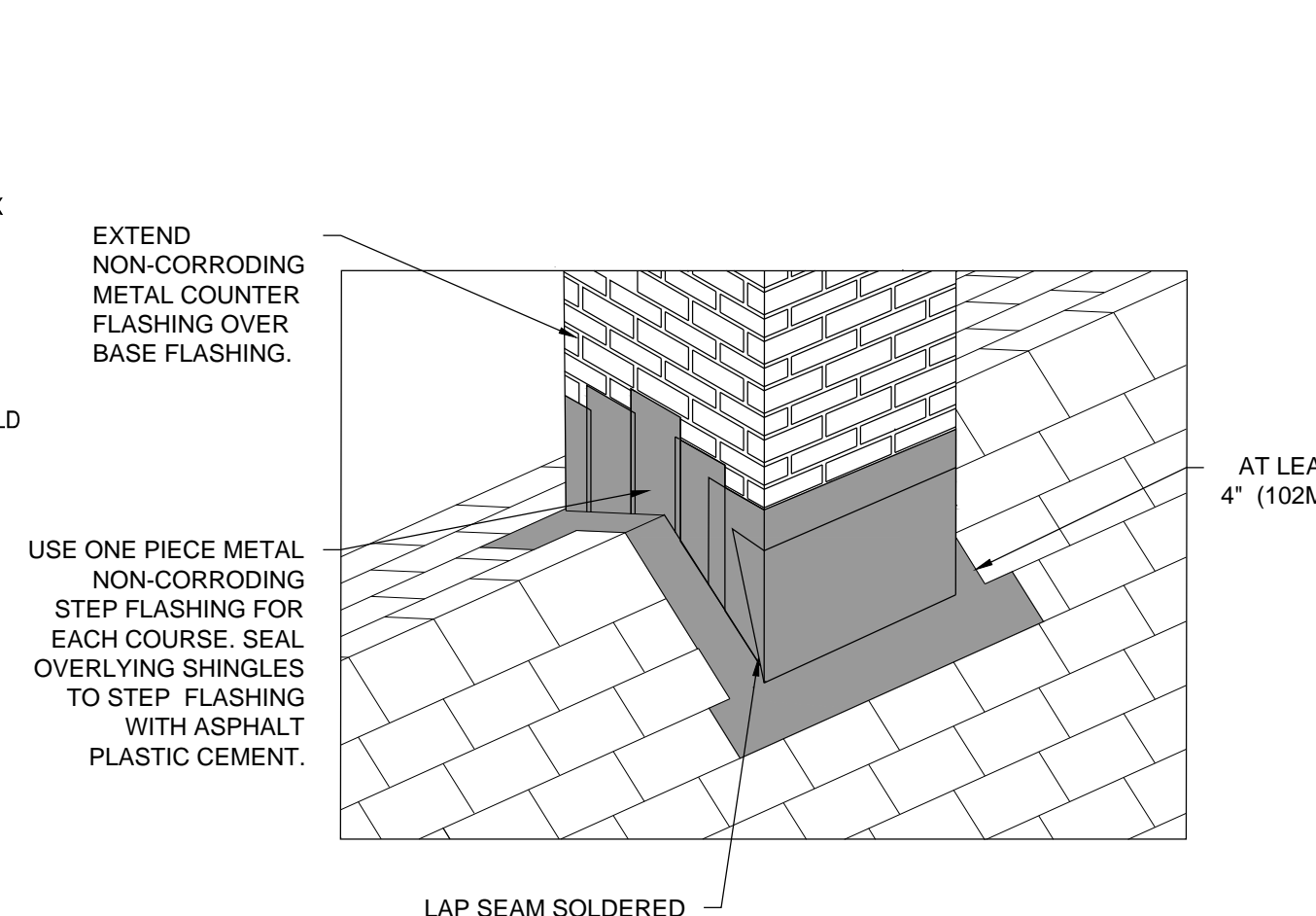

40 CHIMNEY FLASHING DETAIL ON RIDGE OF SLATE ROOF
 SCALE: NOT TO SCALE

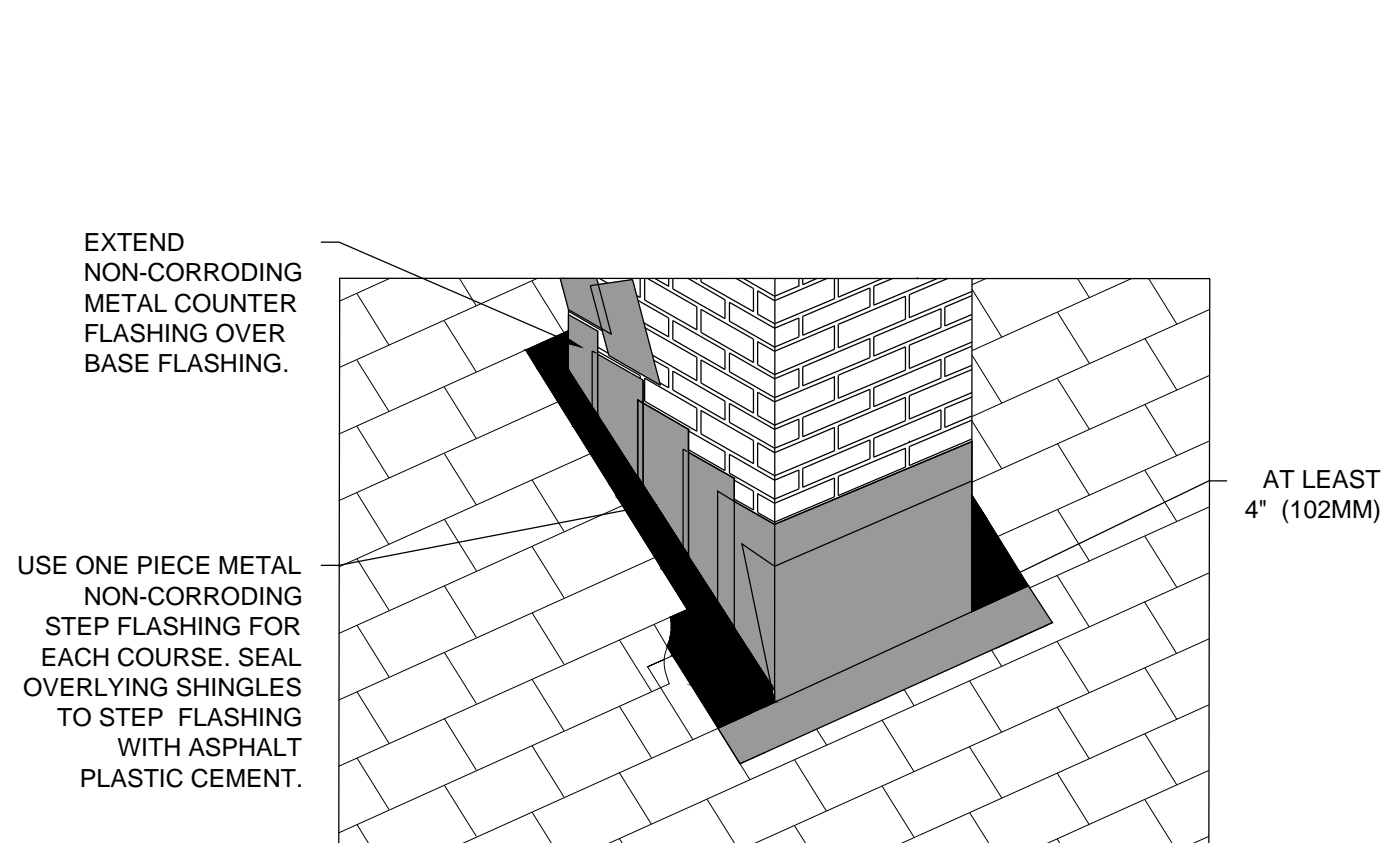

30 CHIMNEY FLASHING DETAIL ON SLOPE OF SLATE ROOF
 SCALE: NOT TO SCALE

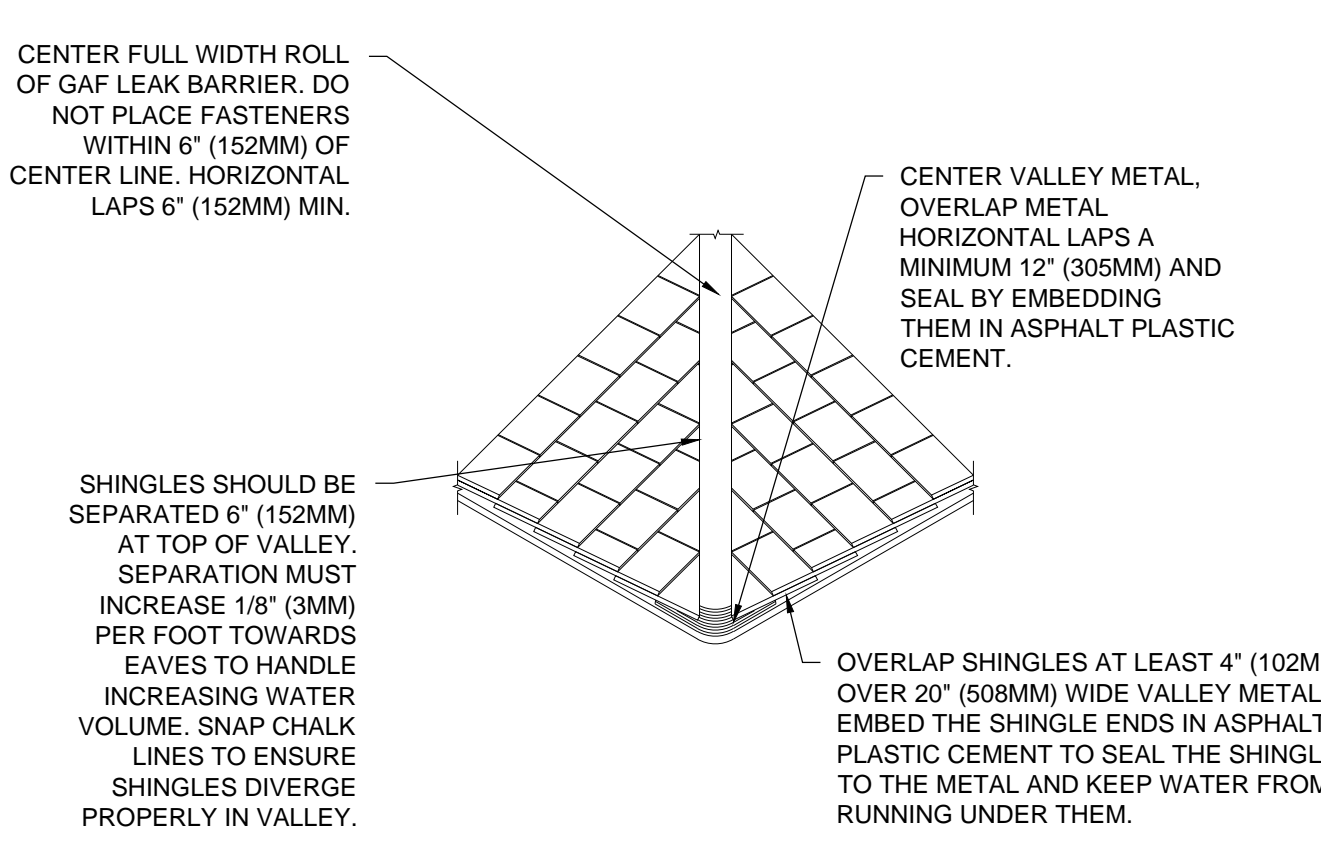

20 OPEN VALLEY DETAIL
 SCALE: NOT TO SCALE

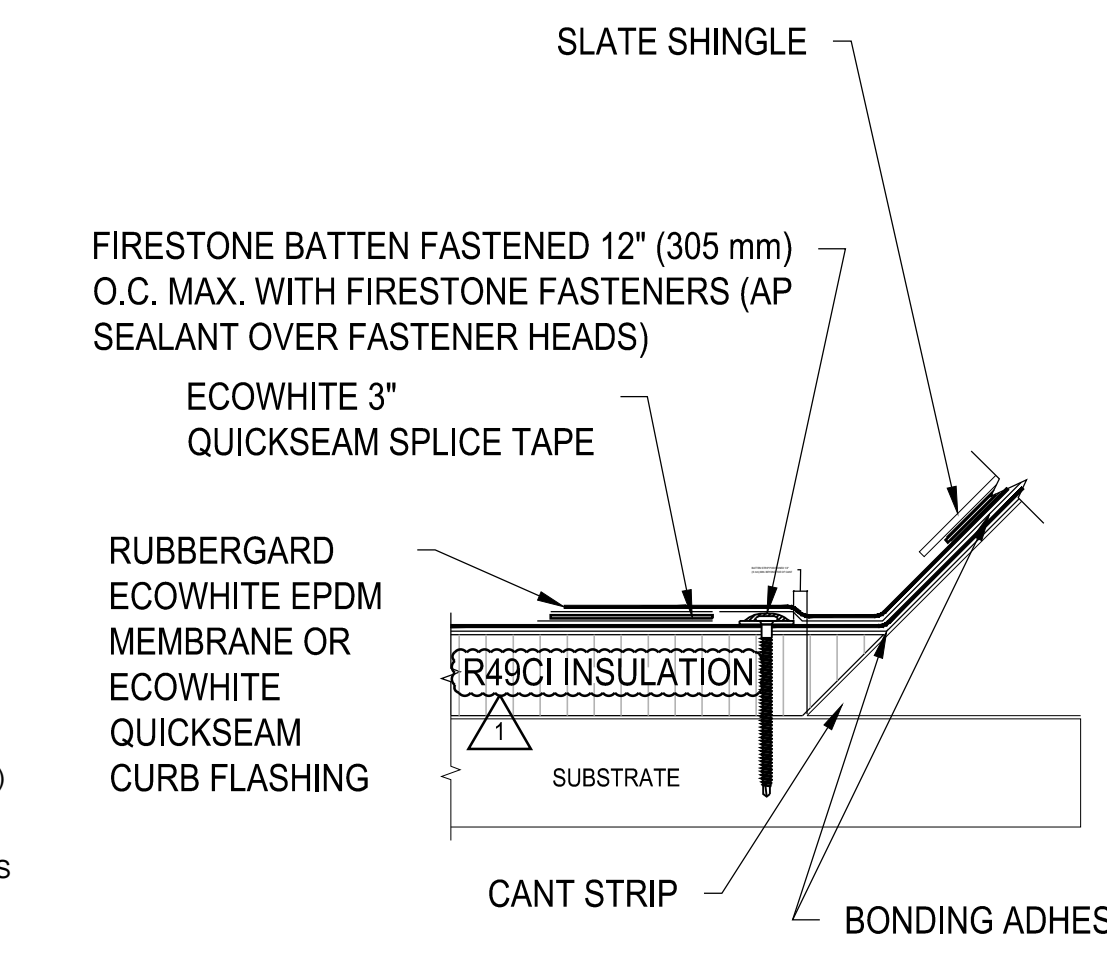

10 TIE-IN AT SLATE ROOF
 SCALE: NOT TO SCALE