

City of Portland, Maine - Building or Use Permit Application

389 Congress Street, 04101 Tel: (207) 874-8703, Fax: (207) 874-8716

Permit No: 2013-00046	Issue Date:	CBL: 268 A002001
--------------------------	-------------	---------------------

Location of Construction: 191 RIVERSIDE ST		Owner Name: CAR SUM ME RIVER LLC		Owner Address: 8270 GREENSBORO DR STE 950 MCLEAN, VA 22102		Phone:	
Business Name: Berlin City Motors		Contractor Name: Titan Mechanical Inc.		Contractor Address: 232 Riverside Industrial Pky Portland ME 04103		Phone: (207) 878-5223	
Lessee/Buyer's Name		Phone:		Permit Type: HVAC		Zone: B4	
Past Use: Automobile Dealership		Proposed Use: Same: Automobile Dealership		Permit Fee: \$120.00		Cost of Work: \$10,000.00	
Proposed Project Description: Install HVAC Trane gas heater		FIRE DEPT: 2/20/13		<input checked="" type="checkbox"/> Approved <input type="checkbox"/> Denied <input type="checkbox"/> N/A		INSPECTION: Use Group: B/S-1 Type: HVAC MUBEC 2009	
		Signature: <i>[Signature]</i>		Signature: <i>[Signature]</i> 2/11/13		PEDESTRIAN ACTIVITIES DISTRICT (P.A.D.)	
		Action: <input type="checkbox"/> Approved <input type="checkbox"/> Approved w/Conditions <input type="checkbox"/> Denied		Signature:		Date:	

Permit Taken By: bjs	Date Applied For: 01/08/2013	Zoning Approval	
-------------------------	---------------------------------	------------------------	--

1. This permit application does not preclude the Applicant(s) from meeting applicable State and Federal Rules. 2. Building permits do not include plumbing, septic or electrical work. 3. Building permits are void if work is not started within six (6) months of the date of issuance. False information may invalidate a building permit and stop all work..	Special Zone or Reviews <input type="checkbox"/> Shoreland <input type="checkbox"/> Wetland <input type="checkbox"/> Flood Zone <input type="checkbox"/> Subdivision <input type="checkbox"/> Site Plan Maj <input type="checkbox"/> Minor <input type="checkbox"/> MM <input type="checkbox"/>	Zoning Appeal <input type="checkbox"/> Variance <input type="checkbox"/> Miscellaneous <input type="checkbox"/> Conditional Use <input type="checkbox"/> Interpretation <input type="checkbox"/> Approved <input type="checkbox"/> Denied	Historic Preservation <input checked="" type="checkbox"/> Not in District or Landmark <input type="checkbox"/> Does Not Require Review <input type="checkbox"/> Requires Review <input type="checkbox"/> Approved <input type="checkbox"/> Approved w/Conditions <input type="checkbox"/> Denied
	Date: <i>1/8/13</i>	Date:	Date:

SCANNED

CERTIFICATION

I hereby certify that I am the owner of record of the named property, or that the proposed work is authorized by the owner of record and that I have been authorized by the owner to make this application as his authorized agent and I agree to conform to all applicable laws of this jurisdiction. In addition, if a permit for work described in the application is issued, I certify that the code official's authorized representative shall have the authority to enter all areas covered by such permit at any reasonable hour to enforce the provision of the code(s) applicable to such permit.

SIGNATURE OF APPLICANT	ADDRESS	DATE	PHONE
RESPONSIBLE PERSON IN CHARGE OF WORK, TITLE		DATE	PHONE

DISPLAY THIS CARD ON PRINCIPAL FRONTAGE OF WORK



CITY OF PORTLAND BUILDING PERMIT



This is to certify that

CAR SUM ME RIVER LLC /Titan Mechanical Inc.

Located at

191 RIVERSIDE ST

PERMIT ID: 2013-00046

CBL: 268 A002001

has permission to **Install HVAC Trane gas heater**

provided that the person or persons, firm or corporation accepting this permit shall comply with all of the provisions of the Statues of Maine and of the Ordinances of the City of Portland regulating the construction, maintenance and use of the buildings and structures, and of the application on file in the department.

Notification of inspection and written permission procured before this building or part thereof is lathed or otherwise cloed-in. 48 HOUR NOTICE IS REQUIRED.

A final inspection must be completed by owner before this building or part thereof is occupied. If a certificate of occupancy is required, it must be procured prior to occupancy.

A handwritten signature in cursive script, reading 'Jeanne Bouke'.

Fire Prevention Officer

Code Enforcement Officer / Plan Reviewer

**THIS CARD MUST BE POSTED ON THE STREET SIDE OF THE PROPERTY
THERE IS A PENALTY FOR REMOVING THIS CARD**

SCANNED

BUILDING PERMIT INSPECTION PROCEDURES
Please call 874-8703 (ONLY)
or email: buildinginspections@portlandmaine.gov

With the issuance of this permit, the owner, builder or their designee is required to provide adequate notice to the city of Portland Inspections Services for the following inspections. Appointments must be requested 48 to 72 hours in advance of the required inspection. The inspection date will need to be confirmed by this office.

- **Please read the conditions of approval that is attached to this permit!! Contact this office if you have any questions.**
- **Permits expire in 6 months. If the project is not started or ceases for 6 months.**
- **If the inspection requirements are not followed as stated below additional fees may be incurred due to the issuance of a "Stop Work Order" and subsequent release to continue.**

REQUIRED INSPECTIONS:

Final - Commercial

The project cannot move to the next phase prior to the required inspection and approval to continue, REGARDLESS OF THE NOTICE OF CIRCUMSTANCES.

IF THE PERMIT REQUIRES A CERTIFICATE OF OCCUPANCY, IT MUST BE PAID FOR AND ISSUED TO THE OWNER OR DESIGNEE BEFORE THE SPACE MAY BE OCCUPIED.

City of Portland, Maine - Building or Use Permit

389 Congress Street, 04101 Tel: (207) 874-8703, Fax: (207) 874-8716

Permit No: 2013-00046	Date Applied For: 01/08/2013	CBL: 268 A002001
---------------------------------	--	----------------------------

Location of Construction: 191 RIVERSIDE ST	Owner Name: CAR SUM ME RIVER LLC	Owner Address: 8270 GREENSBORO DR STE 950	Phone:
Business Name: Berlin City Motors	Contractor Name: Titan Mechanical Inc.	Contractor Address: 232 Riverside Industrial Pky Portland	Phone (207) 878-5223
Lessee/Buyer's Name	Phone:	Permit Type: HVAC	

Proposed Use: Same: Automobile Dealership	Proposed Project Description: Install HVAC Trane gas heater
---	---

Dept: Zoning	Status: Approved	Reviewer: Marge Schmuckal	Approval Date: 01/08/2013
Note:	Ok to Issue: <input checked="" type="checkbox"/>		
Dept: Building	Status: Approved w/Conditions	Reviewer: Jeanie Bourke	Approval Date: 02/11/2013
Note:	Ok to Issue: <input checked="" type="checkbox"/>		
<ol style="list-style-type: none"> 1) The appliance and venting shall be installed in accordance with the UL listing, manufacturer's specifications, IRC 2009 and NFPA 211 2) The installation of this system shall comply with standards for ventilation and indoor air quality per ASHRAE 62.1 or 62.2-2007 edition. 3) The installation must comply with the State of Maine Gas Regulations. 4) Separate permits are required for any electrical, plumbing, sprinkler, fire alarm, HVAC systems, heating appliances, including pellet/wood stoves, commercial hood exhaust systems and fuel tanks. Separate plans may need to be submitted for approval as a part of this process. 			
Dept: Fire	Status: Approved w/Conditions	Reviewer: Ben Wallace Jr	Approval Date: 02/20/2013
Note:	Ok to Issue: <input checked="" type="checkbox"/>		
<ol style="list-style-type: none"> 1) Installation shall comply with NFPA 211, Standard for Chimneys, Fireplaces, Vents, and Solid Fuel-Burning Appliances; NFPA 54, National Fuel Gas Code; NFPA 70, National Electrical Code; and the manufacturer's published instructions. 2) Installation shall comply with City Code Chapter 10. 3) Fuel-fired boilers shall be protected in accordance with NFPA 1, Fire Code. The heater shall be installed at least 8 ft above the floor. 			



FILL IN AND SIGN WITH INK

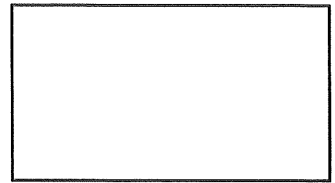

APPLICATION FOR PERMIT HEATING OR POWER EQUIPMENT

To the INSPECTOR OF BUILDINGS, PORTLAND, ME.

The undersigned hereby applies for a permit to install the following heating, cooking or power equipment in accordance with the Laws of Maine, the Building Code of the City of Portland, and the following specifications:

Location / CBL 191 Riverside Use of Building CAR DEALERSHIP Date 1-7-13
 Name and address of owner of appliance BERLIN CITY - TOYOTA SCION 191 RIVERSIDE
ST- PORTLAND MAINE
 Installer's name and address TITAN MECHANICAL INC
 Telephone _____

Location of appliance:

- Basement
- Attic
- Floor
- Roof (JUST BELOW)

Type of Fuel:

- Gas
- Oil
- Solid

Appliance Name:

TRANE

U.L. Approved Yes No

Will appliance be installed in accordance with the manufacture's installation instructions? Yes No

IF NO Explain: _____

The Type of License of Installer:

- Master Plumber # _____
- Solid Fuel # _____
- Oil # _____
- Gas # PNT 1047
- Other _____

Type of Chimney:

- Masonry Lined
Factory built _____

- Metal
Factory Built U.L. Listing # _____

- Direct Vent
Type _____ UL# _____

RECEIVED
JAN 08 2013

Type of Fuel Tank

- Oil
- Gas

Dept. of Building Inspections
City of Portland Maine

Size of Tank _____

Number of Tanks _____

Distance from Tank to Center of Flame _____ feet.

Cost of Work: \$ 10,000

Permit Fee: \$ 120

Approved

Fire: _____

Ele.: _____

Bldg.: _____

Approved with Conditions

- See attached letter or requirement

Signature of Installer

Bob Sullivan

Inspector's Signature

Date Approved



Installation, Operation, and Maintenance

Gas Unit Heater

*Separated Combustion Gas-Fired Propeller Unit
Heater*

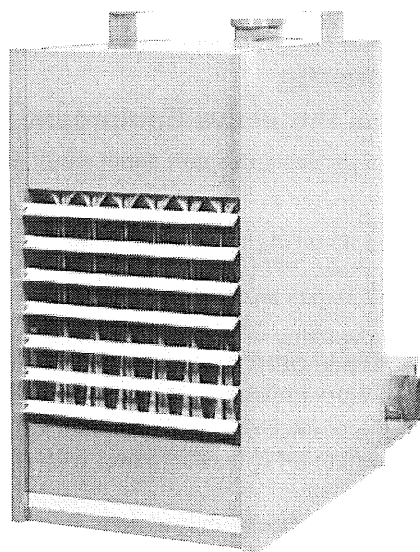

GAND
GAPD

March 2010

GAND-SVX01A-EN





Warnings, Cautions and Notices

Warnings, Cautions and Notices. Note that warnings, cautions and notices appear at appropriate intervals throughout this manual. Warnings are provided to alert installing contractors to potential hazards that could result in personal injury or death. Cautions are designed to alert personnel to hazardous situations that could result in personal injury, while notices indicate a situation that could result in equipment or property-damage-only accidents.

Your personal safety and the proper operation of this machine depend upon the strict observance of these precautions.

ATTENTION: Warnings, Cautions and Notices appear at appropriate sections throughout this literature. Read these carefully.

 **WARNING:** Indicates a potentially hazardous situation which, if not avoided, could result in death or serious injury.

 **CAUTION:** Indicates a potentially hazardous situation which, if not avoided, could result in minor or moderate injury. It could also be used to alert against unsafe practices.

NOTICE: Indicates a situation that could result in equipment or property-damage only accidents.

ATTENTION: READ THIS MANUAL AND ALL LABELS ATTACHED TO THE UNIT CAREFULLY BEFORE ATTEMPTING TO INSTALL, OPERATE OR SERVICE THESE UNITS! CHECK UNIT DATA PLATE FOR TYPE OF GAS AND ELECTRICAL SPECIFICATIONS AND MAKE CERTAIN THAT THESE AGREE WITH THOSE AT POINT OF INSTALLATION. RECORD THE UNIT MODEL AND SERIAL No.(s) IN THE SPACE PROVIDED. RETAIN FOR FUTURE REFERENCE.

WARNING

Personal Protective Equipment (PPE) Required!

Installing/servicing this unit could result in exposure to electrical, mechanical and chemical hazards.

- Before installing/servicing this unit, technicians **MUST** put on all Personal Protective Equipment (PPE) recommended for the work being undertaken. **ALWAYS** refer to appropriate MSDS sheets and OSHA guidelines for proper PPE.
- When working with or around hazardous chemicals, **ALWAYS** refer to the appropriate MSDS sheets and OSHA guidelines for information on allowable personal exposure levels, proper respiratory protection and handling recommendations.
- If there is a risk of arc or flash, technicians **MUST** put on all necessary Personal Protective Equipment (PPE) in accordance with NFPA70E for arc/flash protection **PRIOR** to servicing the unit.

Failure to follow recommendations could result in death or serious injury.

WARNING

Proper Field Wiring and Grounding Required!

All field wiring **MUST** be performed by qualified personnel. Improperly installed and grounded field wiring poses **FIRE & ELECTROCUTION** hazards. To avoid these hazards, you **MUST** follow requirements for field wiring installation and grounding as described in NEC and your local/state electrical codes. Failure to follow these requirements could result in death or serious injury.

 WARNING**Hazardous Service Procedures!**

The maintenance and troubleshooting procedures recommended in this manual could result in exposure to electrical, mechanical or other potential safety hazards. Always refer to the safety warnings provided throughout this manual concerning these procedures. When possible, disconnect all electrical power including remote disconnect and discharge all energy storing devices such as capacitors before servicing. Follow proper lockout/tagout procedures to ensure the power can not be inadvertently energized. When necessary to work with live electrical components, have a qualified licensed electrician or other individual who has been trained in handling live electrical components perform these tasks. Failure to follow all of the recommended safety warnings provided, could result in death or serious injury.

 WARNING**Overheating or Flooding Could Cause Fire or Explosion!**

Overheating or flooding (where any part of the unit heater has been under water) could result in fire or explosion. Should overheating occur, or the gas supply fails to shut off, shut off the manual gas valve to the unit heater before shutting off the electrical supply. Do not use the unit heater if any part has been under water. Immediately call a qualified service technician to inspect the unit heater and replace any gas control which has been underwater. Failure to follow these recommendations could result in death or serious injury.

 WARNING**Hazardous Gases and Flammable Vapors!**

Exposure to hazardous gases from fuel substances have been shown to cause cancer, birth defects or other reproductive harm. Improper installation, adjustment, alteration, service or use of this product could cause flammable mixtures. To avoid hazardous gases and flammable vapors follow proper installation and set up of this product and all warnings as provided in this manual. Failure to follow all instructions could result in death or serious injury.



Introduction

WARNING **Safety Alert!**

You **MUST** follow all recommendations below. Failure to do so could result in death or serious injury.

For Your Safety

The use and storage of gasoline or other flammable vapors and liquids in open containers in the vicinity of this appliance is hazardous.

If you smell gas:

- 1. Open windows.**
- 2. Do not touch electrical switches.**
- 3. Extinguish any open flame.**
- 4. Immediately call your gas supplier from a neighbor's phone. Follow the gas supplier's instructions.**

Approved For Use in California

WARNING **Toxic Hazard!**

Install, operate and maintain unit in accordance with manufacturer's instructions to avoid exposure to fuel substances or substances from incomplete combustion which could result in death or serious illness. The state of California has determined that these substances may cause cancer, birth defects, or other reproductive harm.

Installer's Responsibility

Installer Please Note: This equipment has been test fired and inspected. It has been shipped free from defects from our factory. However, during shipment and installation, problems such as loose wires, leaks, or loose fasteners may occur. It is the installer's responsibility to inspect and correct any problems that may be found.

Receiving Instructions

Inspect shipment immediately when received to determine if any damage has occurred to the unit during shipment. After the unit has been uncrated, check for any visible damage to the unit. If any damage is found, the consignee should sign the bill of lading indicating such damage and immediately file claim for damage with the transportation company.

Important: *It is the equipment owner's responsibility to provide any scaffolding or other apparatus required to perform emergency service or annual/periodic maintenance to this equipment.*

Trademarks

Trane and the Trane logo are trademarks of Trane in the United States and other countries.



Table of Contents

Model Number Descriptions	6
Indoor Gas Heating Units	6
General Information	7
Description	7
General Safety Information	7
Identification of Parts	9
Unit Dimensions and Weights	11
Installation - Mechanical	13
Air Distribution	14
Clearances	15
Nozzle Assembly	16
Installation - Piping	20
Gas Supply Piping	20
Pipe Sizing	20
Pipe Installation	21
Installation - Venting	23
Combustion Air Venting and Piping	23
Exhaust Venting	24
Installation - Concentric Vent Terminal	27
Horizontal Termination	27
Vertical Termination	29
Installation - Electrical	32
Electrical Connections	32
Thermostat Wiring and Location	32
Start-Up	34
Operation	34
Gas Equipment Start-Up	40
Maintenance	41
Periodic Service	41
Installation Instructions for Field Replacement of Power Venter Motor ..	44
How to Order Replacement Parts	45
Diagnostics	46
Troubleshooting	46
Wiring Diagrams	51



Model Numbers

Model Number Descriptions

Indoor Gas Heating Units

Note: All units are AGA approved. For CGA approved units, contact Air Handling Product Support.

Digit 1 – Gas Heating Equipment

G = Gas Heating Equipment

Digit 2 – Product Type

A = Separated Combustion Propeller Fan Unit Heater

Digit 3 – Fuel

N = Natural Gas
P = LP Gas (Propane)

Digit 4 – Development Sequence

D = Fourth Generation

Digits 5, 6, 7 – Input Capacity

Single Furnace

003 = 30 MBh	015 = 150 MBh
004 = 45 MBh	017 = 175 MBh
006 = 60 MBh	020 = 200 MBh
007 = 75 MBh	022 = 225 MBh
009 = 90 MBh	025 = 250 MBh
010 = 100 MBh	030 = 300 MBh
012 = 125 MBh	035 = 350 MBh
	040 = 400 MBh

Digit 8 – Main Power Supply

A = 115/60/1	D = 230/60/3
B = 230/60/1	E = 460/60/3
C = 208/60/3	F = 575/60/3

Digit 9 – Gas Control Option

D = Single-Stage, Intermittent Pilot Ignition
 E = Two-Stage, Intermittent Pilot Ignition
 H = Electronic Modulating with Room T-Stat, Intermittent Pilot Ignition
 J = Electronic Modulating with Duct-Stat, Intermittent Pilot Ignition
 L = Electronic Modulating with External 4–20 mA Input
 N = Electronic Modulating with External 0–10 Vdc Input
 T = Single Stage Direct Spark Ignition
 V = Two-Stage, Direct Spark Ignition

Digit 10 – Design Sequence

G = Seventh Design

Digit 11 – Heat Exchanger Material

1 = Aluminized Steel
3 = #321 Stainless Steel

Digit 12 – Rooftop Arrangements

0 = None (Indoor Unit)

Digit 13 – Rooftop Heating Unit Motor Selection

0 = None (Indoor Unit and Rooftop Duct Furnace)

Digit 14 – Rooftop Fan Section

0 = None (Indoor Unit and Rooftop Duct Furnace)

Digit 15 – Miscellaneous Options

All Units

0 = None
A = #409 Stainless Steel Burners
B = Orifices For Elevation Above 2000 Feet (Specify Elevation)

Propeller Fan Unit Heater (High Efficiency and Separated Combustion)

C = #409 Stainless Steel Draft Diverter
D = Summer-Winter Switch
E = Vertical Louvers
J = Totally Enclosed Motor
7 = OSHA Fan Guard

Centrifugal Fan Unit Heater (High Efficiency and Separated Combustion)

C = #409 Stainless Steel Draft Diverter
D = Summer-Winter Switch
E = Vertical Louvers
H = Duct Discharge Flange
J = Totally Enclosed Motor

Duct Furnace (Indoor) (High Efficiency)

C = #409 Stainless Steel Draft Diverter
D = Summer-Winter Switch
F = Horizontal Louvers
G = Horizontal and Vertical Louvers
K = Side Access Burner Drawer (Left Hand)¹
L = Fan Time Delay Control
M = Side Access Burner Drawer (Right Hand)¹

Separated Combustion, Indoor Duct Furnace

C = #409 Stainless Steel Draft Diverter
D = Summer-Winter Switch
F = Horizontal Louvers
G = Horizontal and Vertical Louvers

Tubular Heat Exchanger, Propeller Type

J = Totally Enclosed Motor
7 = OSHA Fan Guard

¹ The left or right hand side of the side access burner drawer, options K & M, is determined by facing the air outlet side of the duct furnace.

General Information

Description

The Power Vented Gas Unit Heater is a factory assembled, power vented, low static pressure type designed propeller fan heater designed to be suspended within the space to be heated. THESE HEATERS ARE NOT TO BE CONNECTED TO DUCTWORK. The designs are certified by CSA International as providing a minimum of 80 percent thermal efficiency, and approved for use in California. **Do not alter these units in any way.** If you have any questions after reading this manual, contact the manufacturer.

Figure 1. Power Vented Separated Combustion Propeller Unit Heaters

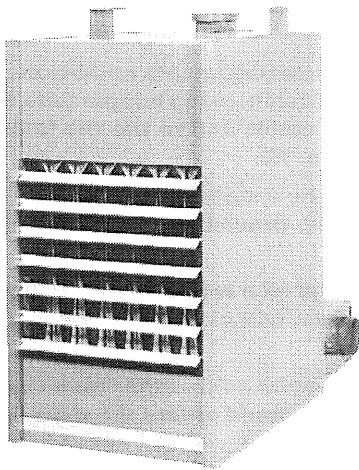

Front view

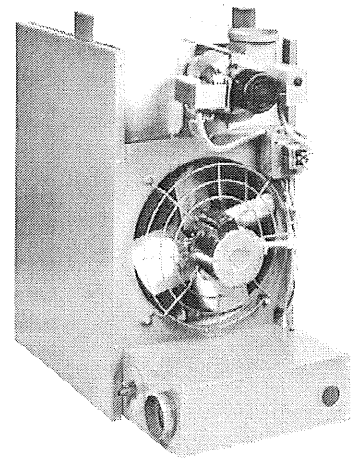

Rear view

See "Identification of Parts," p. 9 for unit components.

General Safety Information

Important: This product must be installed by a licensed plumber or gas fitter when installed within the Commonwealth of Massachusetts.

WARNING

Safety Alert!

You MUST follow all recommendations below. Failure to do so could result in death or serious injury.

- Installation must be made in accordance with local codes, or in absence of local codes with the latest edition of ANSI Standard Z223.1 (N.F.P.A. No. 54) National Fuel Gas Code.

All of the ANSI and NFPA Standards referred to in these installation instructions are those that were applicable at the time the design of this appliance was certified. The ANSI Standards are available from the American National Standards Institute, INC., 11 West 42nd Street, New York, NY, 10036 or www.ansi.org. The NFPA Standards are available from the National Fire Protection Association, Batterymarch Park, Quincy, MA 02269. These unit heaters are designed for use in airplane hangars when installed in accordance with current ANSI/NFPA No. 409 and in public garages when installed in accordance with current NFPA No. 88A and NFPA No. 88B.



General Information

If installed in Canada, the installation must conform with local building codes, or in absence of local building codes, with CGA-B149.1 "Installation Codes for Natural Gas Burning Appliances and Equipment" or CGA-B149.2 "Installation Codes for Propane Gas Burning Appliances and Equipment." These Unit Heaters have been designed and certified to comply with CGA 2.6. Also see sections on installation in "Aircraft Hangers," p. 13 and "Public Garages," p. 13.

- Do not alter the unit heater in any way or damage to the unit and/or severe personal injury or death could occur!
- Turn off the gas supply and disconnect all electric power, including remote disconnects before servicing unit. Follow proper lockout/tagout procedures to ensure the power can not be inadvertently energized and the gas can not be inadvertently turned on. Failure to turn off gas or disconnect power before servicing could result in death or serious injury.
- Follow installation instructions CAREFULLY to avoid creating unsafe conditions. All wiring should be done and checked by a qualified electrician, using copper wire only. All external wiring must conform to applicable local codes and to the the latest edition of the National Electrical Code ANSI/NFPA No. 70.
- All gas connections should be made and leak-tested by a suitably qualified individual, per instructions in this manual. Also follow procedures listed in "Gas Equipment Start-Up," p. 40.
- Use only the fuel for which the unit heater is designed (see rating plate). Using LP gas in a heater that requires natural gas, or vice versa, will create the risk of gas leaks, carbon monoxide poisoning and explosion.

Important: *Do not attempt to convert the heater for use with a fuel other than the one intended. Such conversion is dangerous, as it could create the risks listed previously.*

- Make certain that the power source conforms to the electrical requirements of the heater.
- All field-installed wiring must be completed by qualified personnel. All field-installed wiring must comply with NEC and applicable local codes. Failure to follow this instruction could result in death or serious injuries.
- Special attention must be given to any grounding information pertaining to this heater. To prevent the risk of electrocution, the heater must be securely and adequately grounded. This should be accomplished by connecting a grounded conductor between the service panel and the heater. To ensure a proper ground, the grounding means must be tested by a qualified electrician.
- Do not insert fingers or foreign objects into the heater or its air moving device. Do not block or tamper with the heater in any manner while in operation or just after it has been turned off, as some parts may be hot enough to cause injury.
- This heater is intended for general heating applications ONLY. It must NOT be used in potentially dangerous locations such as flammable, explosive, chemical-laden or wet atmospheres.
- Do not attach ductwork to this product or use it as a makeup air heater. Such usage voids the warranty and will create unsafe operation.
- In cases in which property damage may result from malfunction of the heater, a backup system or a temperature sensitive alarm should be used.
- When connecting to existing gas lines be sure to valve off the gas supply ahead of connection point. To avoid explosion or possible fire, always purge all residual gas from piping before cutting into existing line or removing threaded fittings. Failure

to remove all gas vapors could result in death or serious injury or equipment or property-only-damage.

Unless otherwise specified, the following conversions may be used for calculating SI unit measurements:

1 foot = 0.305 m	1 inch water column = 0.249 kPa
1 inch = 25.4 mm	1 meter/second = FPM ÷ 196.8
1 psig = 6.894 kPa	1 liter/second = CFM × 0.472
1 pound = 0.453 kg	1000 Btu per hour = 0.293 kW
1 gallon = 3.785 L	1000 Btu/Cu. Ft. = 37.5 MJ/m ³
	1 cubic foot = 0.028 m ³

Identification of Parts

Figure 2. Combustion chamber

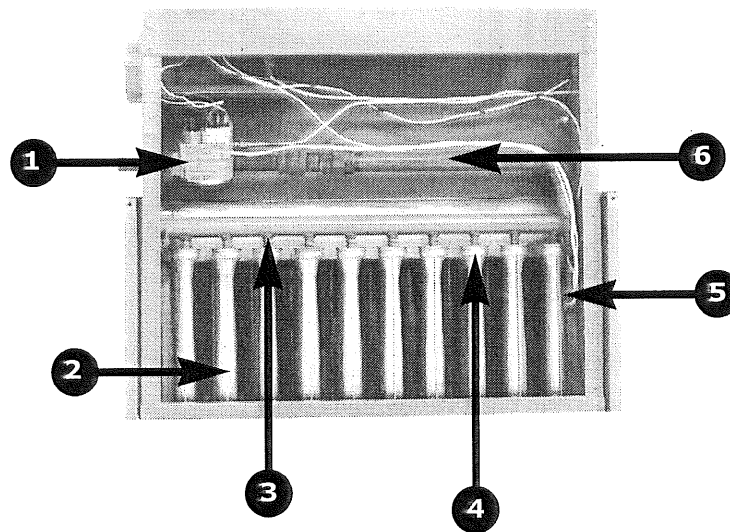

1. Gas valve
2. Main burners
3. Retainer spring
4. Air shutters
5. Pilot assy.
6. Manifold

Figure 3. Internal furnace assembly

MANIFOLD & MAIN BURNERS
INCLUDED IN BURNER
COMPARTMENT ASS'Y.

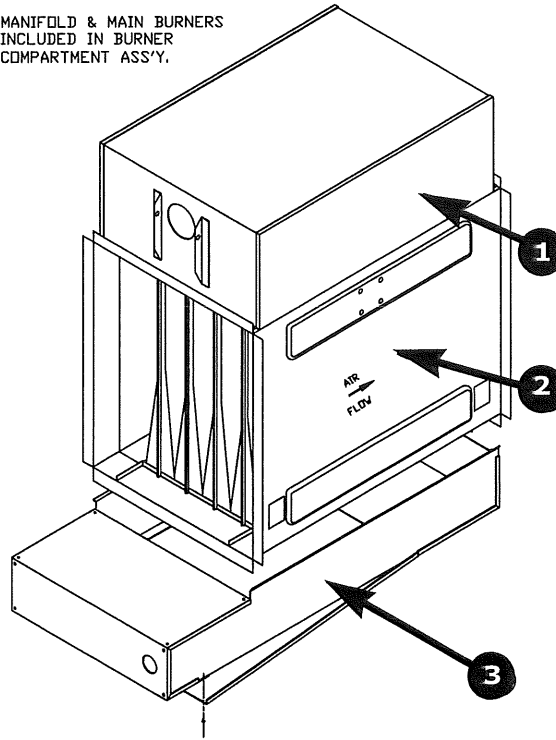

1. Flue Collector
2. Heat Exchanger
3. Burner Drawer

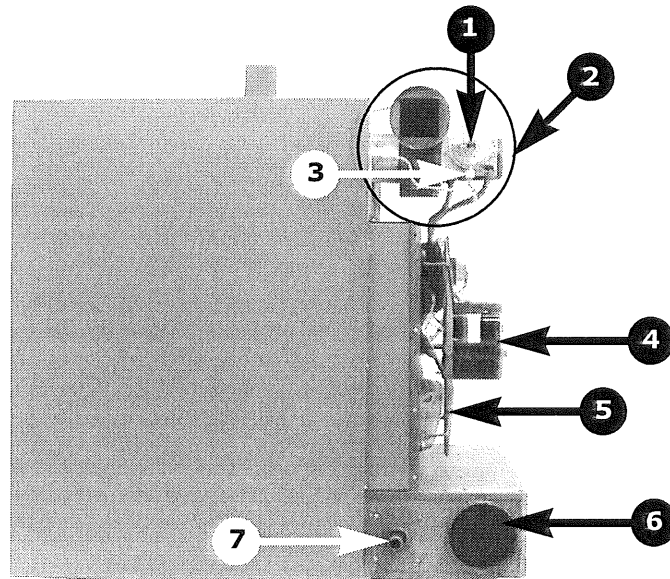
Figure 4. Separated Combustion Unit Heater

1. Pressure switch
2. Power vent assy.
3. Power vent motor
4. Fan motor
5. Fan guard
6. Air inlet
7. Gas supply inlet



Unit Dimensions and Weights

Table 1. Performance and specification data: Separated Combustion Blower Unit Heater

Unit Size		100	125	150	175	200	225	250	300	350	400
PERFORMANCE DATA^(a)											
Input	BTU/Hr (kW)	100,000 (29.3)	125,000 (36.6)	150,000 (43.9)	175,000 (51.2)	200,000 (58.6)	225,000 (65.9)	250,000 (73.2)	300,000 (87.8)	350,000 (102.5)	400,000 (117.1)
Output	BTU/Hr (kW)	80,000 (23.4)	100,000 (29.3)	120,000 (35.1)	140,000 (41.0)	160,000 (46.9)	180,000 (52.7)	200,000 (58.6)	240,000 (70.3)	280,000 (82.0)	320,000 (93.7)
Thermal Efficiency	%	80	80	80	80	80	80	80	80	80	80
Free Air Delivery CFM	cfm (m ³ /s)	1,480 (0.699)	1,650 (0.779)	2200 (1.038)	2,530 (1.194)	2,640 (1.246)	2,700 (1.274)	3,100 (1.463)	4,400 (2.077)	5,000 (2.360)	5,300 (2.502)
Air Temperature Rise	°F (°C)	50 (10)	56 (13)	50 (10)	51 (11)	56 (13)	61 (16)	60 (16)	50 (10)	52 (11)	56 (13)
Outlet Velocity	fpm (m/s)	775 (3.9)	910 (4.6)	1045 (5.3)	1070 (5.4)	1000 (5.1)	950 (4.8)	980 (5.0)	1100 (5.6)	1150 (5.8)	1050 (5.3)
Full Load Amps at 115V		5.8	6.0	7.2	7.8	7.8	7.8	8.8	11.2	12.2	12.2
MOTOR DATA:											
Motor	hp (kW)	1/20 (0.037)	1/10 (0.075)	1/4 (0.186)	1/3 (0.249)	1/3 (0.249)	1/3 (0.249)	1/2 (0.373)	(2)1/4 (0.186)	(2)1/3 (0.249)	(2)1/3 (0.249)
Type		SP	SP	PSC	PSC	PSC	PSC	PSC	PSC	PSC	PSC
RPM		1,050	1,050	1,140	1,140	1,140	1,140	1,140	1,140	1,140	1,140
Amps @ 115V		2.6	2.8	4.0	4.5	4.5	4.5	5.5	8.0	9.0	9.0
DIMENSIONAL DATA											
"A" Height to Top of Unit	in. (mm)	31-1/4 (794)	31-1/4 (794)	36-1/4 (921)	36-1/4 (921)	36-1/4 (921)	36-1/4 (921)	36-1/4 (921)	36-1/4 (921)	36-1/4 (921)	36-1/4 (921)
"B" Height to Top of Hanger	in. (mm)	34-1/16 (865)	34-1/16 (865)	39-1/16 (992)	39-1/16 (992)	39-1/16 (992)	39-1/16 (992)	39-1/16 (992)	39-1/16 (992)	39-1/16 (992)	39-1/16 (992)
"C" Hanging Distance Width	in. (mm)	14-3/4 (375)	17-1/2 (445)	17-1/2 (445)	20-1/4 (514)	23 (584)	25-3/4 (654)	28-1/2 (724)	34 (864)	39-1/2 (1003)	45 (1143)
"D" Discharge Opening Width	in. (mm)	15-3/8 (391)	18-1/8 (460)	18-1/8 (460)	20-7/8 (530)	23-5/8 (600)	26-3/8 (670)	29-1/8 (740)	34-5/8 (879)	40-1/8 (1019)	45-5/8 (1159)
"E" Width of Unit	in. (mm)	17-7/8 (454)	20-5/8 (524)	20-5/8 (524)	23-3/8 (594)	26-1/8 (664)	28-7/8 (733)	31-5/8 (803)	37-1/8 (943)	42-5/8 (1083)	48-1/8 (1222)
"F" to Centerline of Flue	in. (mm)	5-7/8 (149)	7-1/4 (184)	7-1/4 (184)	8-5/8 (219)	10 (254)	11-1/4 (286)	12-3/4 (324)	15-1/2 (394)	18-1/4 (464)	21 (533)
Flue Size Dia.	in.** (mm)	4 (102)	4 (102)	4 (102)	4 (102)	5 (127)	5 (127)	5 (127)	6 (152)	6 (152)	6 (152)
Air Inlet Size	in. (mm)	4 (102)	4 (102)	4 (102)	4 (102)	5 (127)	5 (127)	5 (127)	6 (152)	6 (152)	6 (152)
Fan Diameter	in.	14	16	16	18	18	18	18	16	18	18
Gas Inlet-Natural Gas	in.	1/2	1/2	1/2	1/2	1/2	3/4	3/4	3/4	3/4	3/4
Gas Inlet-LP Gas	in.	1/2	1/2	1/2	1/2	1/2			1/2 or 3/4		
Approx. Shipping Wt.	lb (kg)	200 (91)	228 (103)	256 (116)	284 (129)	312 (142)	340 (154)	368 (167)	432 (196)	488 (221)	545 (247)

Notes:

- For installations in Canada, any references to deration at altitudes in excess of 2000 ft. (610m) are to be ignored. At altitudes of 2000 to 4500 ft. (610m to 1372m), the unit must be derated to 90% of the normal altitude rating, and be so marked in accordance with the C.G.A. certification.
- Legend: SPH = SPLIT PHASE, CAP. START = CAPACITOR START

(a) Ratings shown are for unit installations at elevations between 0 and 2000 ft. (610 m). For unit installations in USA above 2000 ft. (610 m), the unit input must be derated 4% for each 1000 ft. (305 m) above sea level; refer to local codes, or in absence of local codes, refer to the latest edition of the National Gas Code, ANSI Standard Z223.1 (N.F.P.A. No. 54).

** Refer to corresponding ** in Figure 5, p. 12.

Unit Dimensions and Weights

Figure 5. Dimensions, standard units

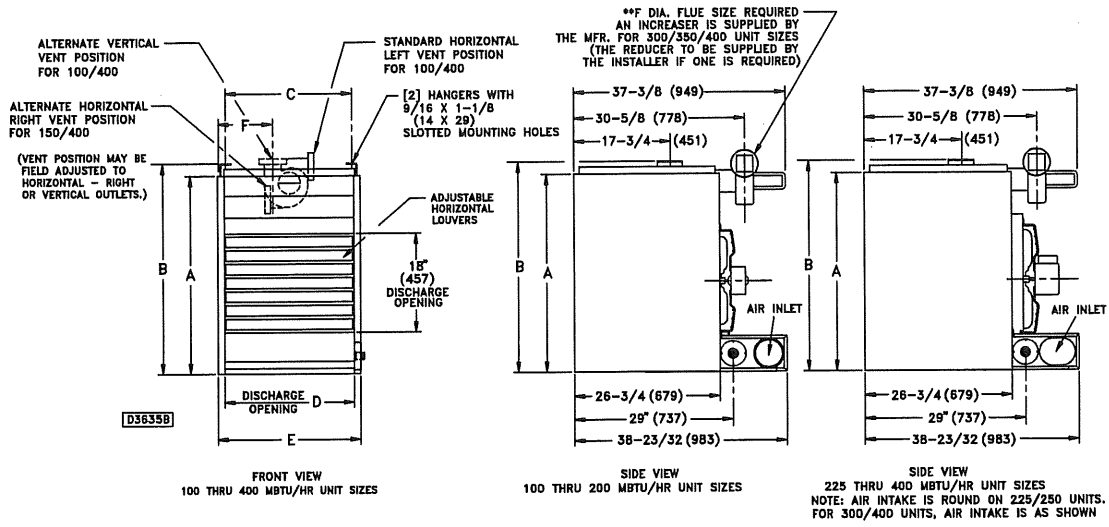

Installation - Mechanical

NOTICE:

Equipment Damage!

Do not install unit heaters in corrosive or flammable atmospheres! Premature failure of, or severe damage to the unit could result! Avoid locations where extreme drafts can affect burner operation. Unit heaters must not be installed in locations where air for combustion would contain chlorinated, halogenated or acidic vapors. If located in such an environment, premature failure of the unit could occur!

Since the unit is equipped with an automatic gas ignition system, the unit heaters must be installed such that the gas ignition control system is not directly exposed to water spray, rain, or dripping water.

Note: Location of unit heaters is related directly to the selection of sizes (refer to Figure 6). Basic rules are as follows:

Figure 6. Heater location

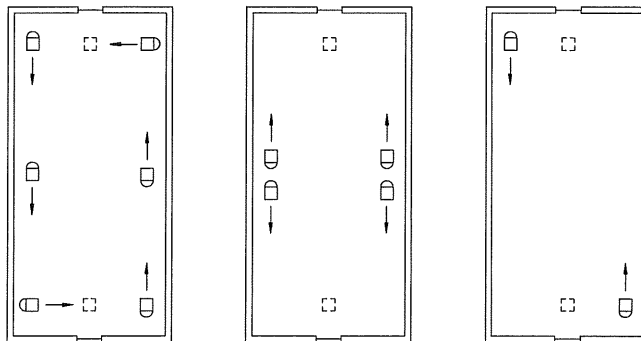

Mounting Height. Unit Heaters must be installed at a minimum of 8 feet (2.4 m) above the floor, measured to the bottom of the unit. At heights above 8 feet (2.4 m), less efficient air distribution will result. Occasionally unit heaters must be mounted at heights of 12 to 16 feet (3.7 to 4.9 m) in order to clear obstacles. When this is the case, it is advisable to use centrifugal blower unit heaters. If the unit heater to be mounted below 8 feet (2.4 m) above the floor, the unit heater must be equipped with an OSHA-approved fan guard.

Aircraft Hangars. Unit Heaters must be installed in aircraft hangars and public garages as follows: in aircraft hangars, unit heaters must be at least 10 feet (3.0 m) above the upper surface of wings or engine enclosures of the highest aircraft to be stored in the hangar, and 8 feet (2.4 m) above the floor in shops, offices and other sections of the hangar where aircraft are not stored or housed. Refer to current ANSI/NFPA No. 409, Aircraft Hangars. In Canada, installation is suitable in aircraft hangars when acceptable to the enforcing authorities.

Public Garages. In repair garages, unit heaters must be located at least 8 feet (2.4 m) above the floor. Refer to the latest edition of NFPA 88B, Repair Garages.

In parking structures, unit heaters must be installed so that the burner flames are located a minimum of 18 inches (457 mm) above the floor or protected by a partition not less than 18 inches (457 mm) high. However, any unit heater mounted in a parking structure less than 8 feet (2.4 m) above the floor must be equipped with an OSHA approved fan guard. Refer to the latest edition of NFPA 88A, Parking Structures.

In Canada, installation must be in accordance with the latest edition of CGA B149 "Installation Codes for Gas Burning Appliances and Equipment."

Air Distribution

Direct air towards areas of maximum heat loss. When multiple heaters are involved, circulation of air around the perimeter is recommended where heated air flows along exposed walls. Satisfactory results can also be obtained where multiple heaters are located toward the center of the area with heated air directed toward the outside walls. Be careful to avoid all obstacles and obstructions which could impede the warm air distribution patterns. Heat throw distances are presented in Table 2, p. 14 and Figure 7.

Table 2. Standard applications approximate heat throw distances (see Figure 7)

"H" ^(a) ft. (m)	Unit Size Btu/h (kW)									
	100,000 (29.3)	125,000 (36.6)	150,000 (43.9)	175,000 (51.2)	200,000 (58.6)	225,000 (65.9)	250,000 (73.2)	300,000 (87.8)	350,000 (102.5)	400,000 (117.1)
8 (2.4)	60 (18.3)	65 (19.8)	70 (21.3)	75 (22.9)	80 (24.4)	85 (25.9)	90 (27.4)	105 (32.0)	110 (33.5)	120 (36.6)
10 (3.0)	54 (16.5)	56 (17.1)	60 (18.3)	64 (19.5)	68 (20.7)	72 (21.9)	78 (23.8)	90 (27.4)	95 (29.0)	100 (30.5)
12 (3.7)	44 (13.4)	46 (14.0)	49 (20.7)	57 (17.4)	61 (18.6)	65 (19.8)	68 (20.7)	80 (24.4)	84 (25.6)	90 (27.4)
15 (4.6)	NR	NR	45 (22.6)	49 (14.9)	52 (15.8)	56 (17.1)	60 (18.3)	70 (21.3)	74 (22.6)	80 (24.4)
20 (6.1)	NR	NR	NR	NR	46 (14.0)	50 (15.2)	54 (16.5)	63 (19.2)	66 (20.1)	70 (21.3)

Note: NR = Not recommended.

(a) H = Distance from floor to bottom of the unit.

Figure 7. Heat throw distances

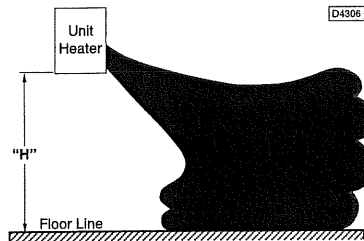

NOTICE:

Maintain Minimum Thermostat Setting!

Unit heaters should not be installed to maintain low temperatures and/or freeze protection of buildings. A minimum of 50°F (10°C) thermostat setting must be maintained. If unit heaters are operated to maintain lower than 50°F (10°C), hot flue gases are cooled inside the heat exchanger to a point where water vapor (a flue gas by-product) condenses onto the heat exchanger walls. The result is a mildly corrosive acid that prematurely corrodes the aluminized heat exchanger and can actually drip water down from the unit heater onto the floor surface. Additional unit heaters should be installed if a minimum 50°F (10°C) thermostat setting cannot be maintained. Failure to follow these recommendations could result in equipment or property damage.

⚠ WARNING

Overheating or Flooding Could Cause Fire or Explosion!

Overheating or flooding (where any part of the unit heater has been under water) could result in fire or explosion. Should overheating occur, or the gas supply fails to shut off, shut off the manual gas valve to the unit heater before shutting off the electrical supply. Do not use the unit heater if any part has been under water. Immediately call a qualified service technician to inspect the unit heater and replace any gas control which has been underwater. Failure to follow these recommendations could result in death or serious injury.

⚠️ WARNING**Hazardous Gases and Flammable Vapors!**

Exposure to hazardous gases from fuel substances have been shown to cause cancer, birth defects or other reproductive harm. Improper installation, adjustment, alteration, service or use of this product could cause flammable mixtures. To avoid hazardous gases and flammable vapors follow proper installation and set up of this product and all warnings as provided in this manual. Failure to follow all instructions could result in death or serious injury.

Note: Unit heater sizing should be based on heat loss calculations where the unit heater output equals or exceeds heat loss. Heater output is approximately 80 percent of input Btu/hr rating.

Clearances

Each Gas Unit Heater shall be located with respect to building construction and other equipment so as to permit access to the Unit Heater. Clearance between walls and the vertical sides of the Unit Heater shall be no less than 18 inches (457 mm). A minimum clearance of 6 inches (152 mm) must be maintained between the top of the Unit Heater and the ceiling. The bottom of the Unit Heater must be no less than 12 inches (305 mm) from any combustible. However, in order to ensure access to the burner compartment, a minimum distance of 25 inches (635 mm) is required. The distance between the flue collector and any combustible must be no less than 6 inches (152 mm). Also see "Combustion Air Venting and Piping," p. 23 and "Exhaust Venting," p. 24.

Note: Increasing the clearance distances may be necessary if there is a possibility of distortion or discoloration of adjacent materials.

⚠️ WARNING**Heavy Objects!**

Make certain that the lifting methods used to lift the heater and the method of suspension used in the field installation of the heater are capable of uniformly supporting the weight of the heater at all times. Make certain that the structure to which the heater is mounted is capable of supporting its weight. Under no circumstances must the gas lines, the venting system or the electrical conduit be used to support the heater; or should any other objects (i.e. ladder, person) lean against the heater, gas lines, venting system or the electrical conduit for support. Failure to follow recommendations could result in death or serious injury.

NOTICE:**Equipment Damage!**

Unit heaters must be hung level from side to side and from front to back, see Figure 5, p. 12 through Figure 9, p. 16. Failure to do so could result in poor performance and/or premature failure of the unit.

⚠️ WARNING**Heavy Objects!**

Ensure that all hardware used in the suspension of each unit heater is capable of supporting the unit weight. Failure to do so could result in unit falling off its mounting location, which could result in death or serious injury.

Note: Refer to Figure 1, p. 7 through Figure 9, p. 16, and dimensional data per Table 1, p. 11 for suspension of units.

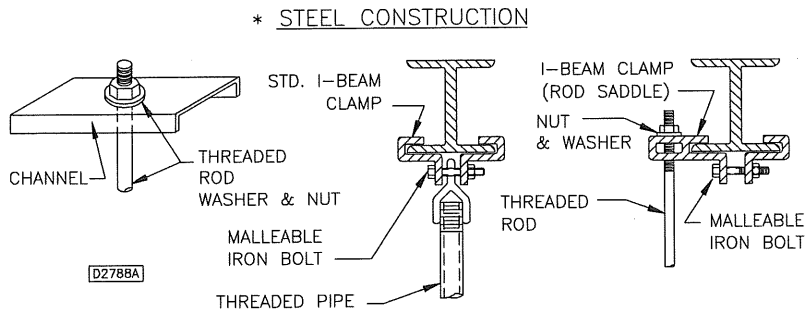
Figure 8. Heater mounting^(a)

(a) All hanging hardware and wood is not included with the unit (to be field supplied).

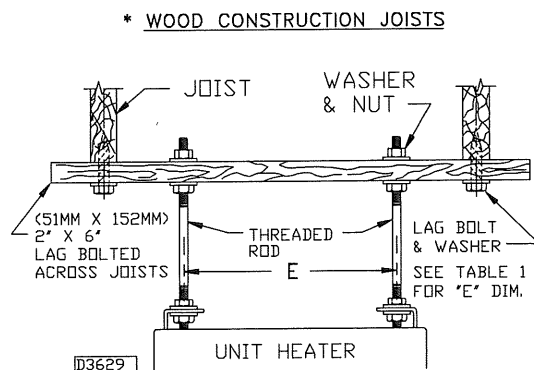
Figure 9. Heater mounting 100/400 MBtu unit sizes

Nozzle Assembly

Use the following procedure for assembling the 30-, 60-, or 90-degree nozzle assembly to your unit heater.

1. Remove the louvers and the cone springs from the unit heater.
2. Remove the four (4) screws from the upper section of the front of the unit heater and use these same screws to temporarily attach the top bracket (P/N 252-07948-00X).
 - a. Using the holes in the top bracket as a guide, pre-drill a 1/8" (0.125") hole at each location across the front panel of the unit heater.
 - b. Using the enclosed screws, permanently attach the top bracket.
3. Remove the upper two (2) screws from the lower section on the front of the unit heater. Repeat the procedure described in Step 2 using the bottom bracket (P/N 252-07949-00X).
4. Using the sixteen (16) 5/16-12 x 1/2 screws, attach the left and right side panel (P/N 251-07944 and 251-07946) to the unit heater using the holes to which the louvers were attached.
5. Using the enclosed #8-18 x 1/2 screws and with the top panel oriented such that the side with the larger holes is facing the unit heater, attach the top panel (P/N 251-07942-00X) to the top bracket and the two (2) side panels.

Note: The top panel must be attached so that the side with the larger holes is facing the unit heater; this is a requirement for later steps in this installation procedure.

6. Using the enclosed #8-18 x 1/2 screws and with the bottom panel oriented such that the side with the larger holes is facing the unit heater, attach the bottom panel (P/N 251-07943-00X) to the bottom bracket and the two (2) side panels.

Note: The bottom panel must be attached so that the side with the larger holes is facing the unit heater; this is a requirement for later steps in this installation procedure.

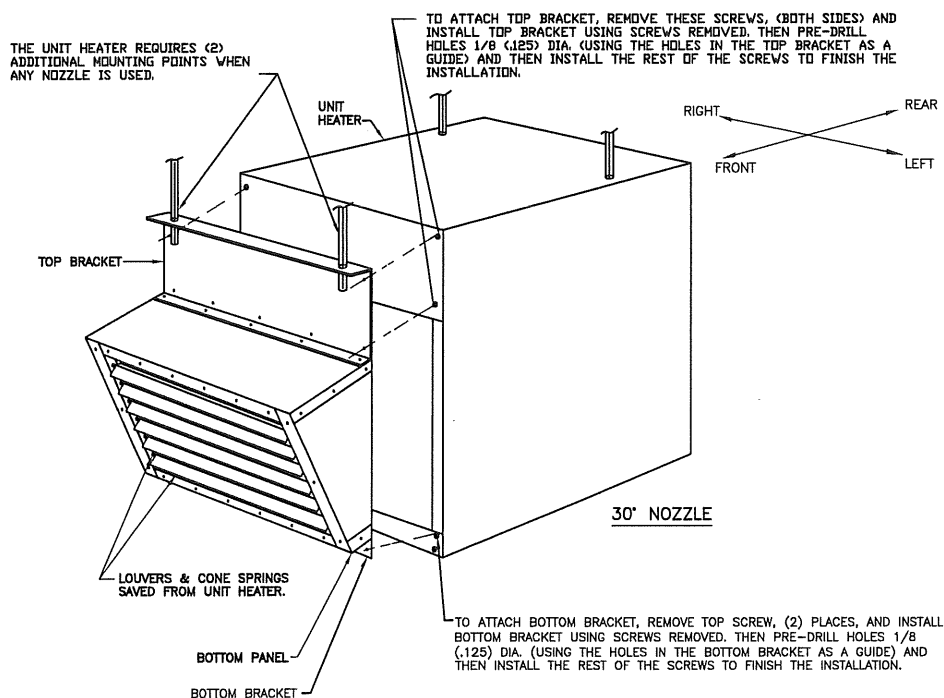

7. For 30-degree nozzle assemblies: Go to Step 10.
8. For 60- and 90-degree nozzle assemblies: Using the enclosed #8-18 x 1/2 screws and with the top and bottom panels oriented such that the sides with the larger holes are facing the unit heater, create a sub-assembly by attaching the top panel (P/N 251-07942-00X) and the bottom panel (P/N 251-07943-00X) to the left side panel (P/N 251-07945) and to the right side panel (P/N 251-07947).

Note: The top and bottom panels must be attached so that the sides with the larger holes are facing the unit heater; this makes the assembly easier.

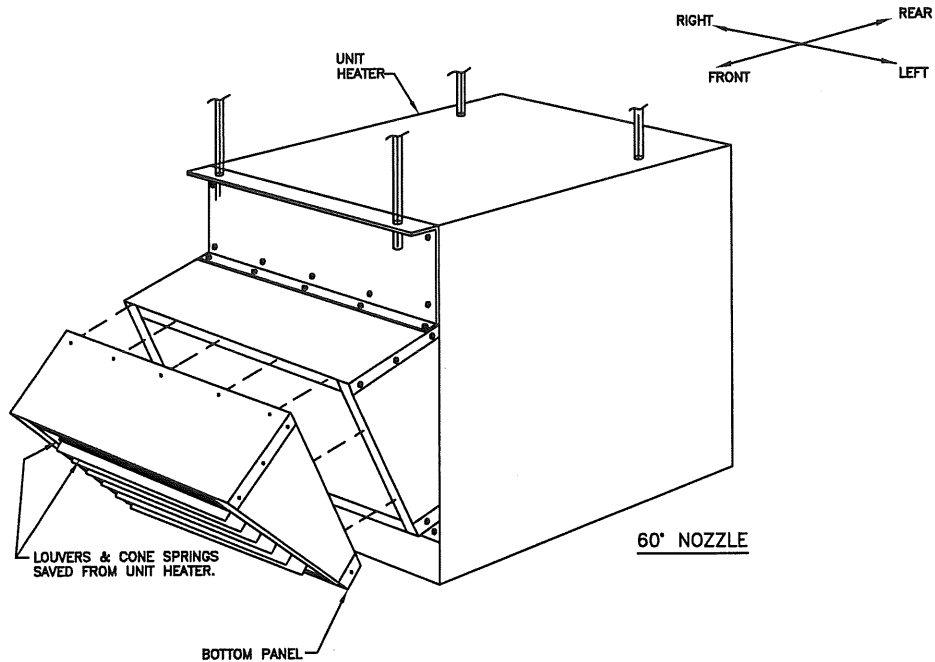

Note: For 90-degree nozzle assemblies, repeat Step 8 to create a second sub-assembly.

9. For 60- and 90-degree nozzle assemblies: Using the enclosed #8-18 x 1/2 screws, attach the sub-assembly created in Step 8 to the 30-degree assembly installed to the unit (in Step 1 through Step 6 of this procedure). Attach the corresponding panels (i.e., top panel to top panel, right side panel to right side panel, etc).

Note: For 90-degree nozzle assemblies, install the second sub-assembly by attaching it to the first sub-assembly. Attach the corresponding panels (i.e., top panel to top panel, right side panel to right side panel, etc).

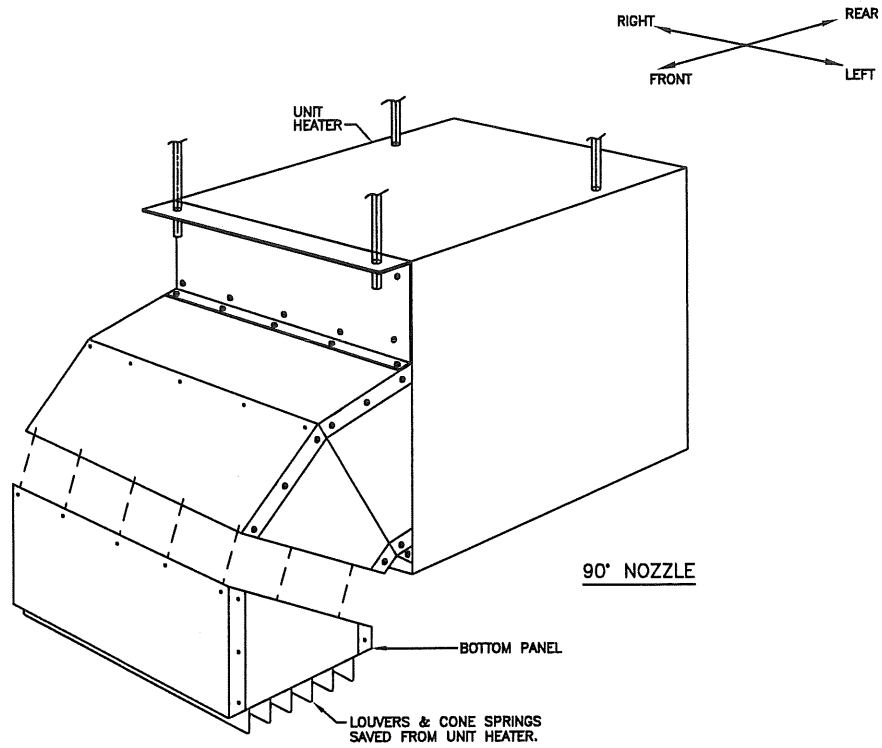

10. Install the louvers and cone springs.



Installation - Piping

Gas Supply Piping

WARNING

Flammable Vapors!

When connecting to existing gas lines be sure to valve off the gas supply ahead of connection point. To avoid explosion or possible fire, always purge all residual gas from piping before cutting into existing line or removing threaded fittings. Failure to remove all gas vapors could result in death or serious injury or equipment or property-only damage.

Pipe Sizing

To provide adequate gas pressure at the gas unit heater, size the gas piping as follows:

1. Find the ft³/hr by using the following formula:

$$\text{ft}^3/\text{hr} = \frac{\text{Input}}{\text{Btu per ft}^3}$$

2. Refer to Table 3, p. 21. Match "Length of Pipe" with appropriate "Gas Input - Ft³/Hr" value. This value can then be matched to the pipe size at the left of the table.

Example: It is determined that a 67 foot (20.4 m) run of gas pipe is required to connect a 200 MBtu gas unit heater to a 1,000 Btu/ft³ (0.29 kW) natural gas supply.

$$\frac{200,000 \text{ Btu/hr}}{1,000 \text{ Btu/ft}^3} = 200 \text{ ft}^3/\text{hr}$$

Using Table 3, p. 21, a 1-inch pipe is needed.

Notes:

- See "General Safety Information," p. 7 for English/SI (metric) unit conversion factors.
- If more than one gas unit heater is to be served by the same piping arrangement, the total cubic feet per hour input and length of pipe must be considered.
- If the gas unit heater is to be fired with LP gas, refer to Table 3 and consult the local LP gas dealer for pipe size information.

WARNING

Hazard of Explosion and Fire!

Heater installation for use with propane (LP gas) must be made by a qualified LP Gas Dealer or LP Gas Installer to ensure that all appropriate codes, installation procedures, and precautions have been followed. Failure to follow these instructions could result in death or serious injury.

Before any connection is made to an existing line supplying other gas appliances, contact the local gas company to make certain that the existing line is of adequate size to handle the combined load.

Table 3. Gas pipe size^(a)

Nominal Iron Pipe Size, in.	Internal Diameter, in. (mm)	Length of Pipe, ft (m)													
		10 (3.0)	20 (6.1)	30 (9.1)	40 (12.2)	50 (15.2)	60 (18.3)	70 (21.3)	80 (24.4)	90 (27.4)	100 (30.5)	125 (38.1)	150 (45.7)	175 (53.3)	200 (61.0)
1/2	0.622 (16)	175 (4.96)	120 (3.40)	97 (2.75)	82 (2.32)	73 (2.07)	66 (1.87)	61 (1.73)	57 (1.61)	53 (1.50)	50 (1.42)	44 (1.25)	40 (1.13)	37 (1.05)	35 (0.99)
3/4	0.824 (21)	360 (10.2)	250 (7.08)	200 (5.66)	170 (4.81)	151 (4.28)	138 (3.91)	125 (3.54)	118 (3.34)	110 (3.11)	103 (2.92)	93 (2.63)	84 (2.38)	77 (2.18)	72 (2.04)
1	1.049 (27)	680 (19.3)	465 (13.2)	375 (10.6)	320 (9.06)	285 (8.07)	260 (7.36)	240 (6.80)	220 (6.23)	205 (5.80)	195 (5.52)	175 (4.96)	160 (4.53)	145 (4.11)	135 (3.82)
1-1/4	1.380 (35)	1400 (39.6)	950 (26.9)	770 (21.8)	660 (18.7)	580 (16.4)	530 (15.0)	490 (13.9)	460 (13.0)	430 (12.2)	400 (11.3)	360 (10.2)	325 (9.20)	300 (8.50)	280 (7.93)
1-1/2	1.610 (41)	2100 (59.5)	1460 (41.3)	1180 (33.4)	990 (28.0)	900 (25.5)	810 (22.9)	750 (21.2)	690 (19.5)	650 (18.4)	620 (17.6)	550 (15.6)	500 (14.2)	460 (13.0)	430 (12.2)
2	2.067 (53)	3950 (112)	2750 (77.9)	2200 (62.3)	1900 (53.8)	1680 (47.6)	1520 (43.0)	1400 (39.6)	1300 (36.8)	1220 (34.5)	1150 (32.6)	1020 (28.9)	950 (26.9)	850 (24.1)	800 (22.7)
2-1/2	2.469 (63)	6300 (178)	4350 (123)	3520 (99.7)	3000 (85.0)	2650 (75.0)	2400 (68.0)	2250 (63.7)	2050 (58.0)	1950 (55.2)	1850 (52.4)	1650 (46.7)	1500 (42.5)	1370 (38.8)	1280 (36.2)
3	3.068 (78)	11000 (311)	7700 (218)	6250 (177)	5300 (150)	4750 (135)	4300 (122)	3900 (110)	3700 (105)	3450 (97.7)	3250 (92.0)	2950 (83.5)	2650 (75.0)	2450 (69.4)	2280 (64.6)
4	4.026 (102)	23000 (651)	15800 (447)	12800 (362)	10900 (309)	9700 (275)	8800 (249)	8100 (229)	7500 (212)	7200 (204)	6700 (190)	6000 (170)	5500 (156)	5000 (142)	4600 (130)

Notes:

1. Determine the required ft³/h by dividing the rated heater input by 1000. For SI / Metric measurements: Convert unit Btu/h to kilowatts. Multiply the unit input (kW) by 0.0965 to determine m³/h.
2. FOR NATURAL GAS: Select the pipe size directly from the table.
3. FOR PROPANE GAS: Multiply the ft³/h (m³/h) value by 0.633; then use the table.
4. Refer to the metric conversion factors listed in "General Safety Information," p. 7 for more SI unit measurements/conversions.

(a) Maximum capacity of pipe in cubic feet of gas per hour (cubic meters per hour) for gas pressures of 0.5 psig (3.5 kPa) or less, and a pressure drop of 0.5 inch water column (124.4 Pa) (based on a 0.60 specific gravity gas).

Pipe Installation

1. Install the gas piping in accordance with applicable local codes.
2. Check gas supply pressure. Each unit heater must be connected to a manifold pressure and a gas supply capable of supplying its full rated capacity as specified in Table 4, p. 23. A field LP tank regulator must be used to limit the supply pressure to maximum of 14 in. wc (3.5 kPa). All piping should be sized in accordance with the latest edition of ANSI Standard Z223.1 National Fuel Gas Code; in Canada, according to CGA B149. See Table 3, p. 21 for correct gas supply piping size. If gas pressure is excessive on natural gas applications, install a pressure regulating valve in the line upstream from the main shutoff valve.

WARNING!

Hazard of Explosion!

Adequately support the piping to prevent strain on the gas manifold and controls. To prevent explosion, fire, or gas leaks, support piping so that piping does not sag or put pressure on the burners internal to the unit. Failure to follow these recommendations could result in death or serious injury or equipment or property-only-damage.

3. To prevent the mixing of moisture with gas, run the take-off piping from the top, or side, of the main.

Installation - Piping

4. Separated combustion unit heaters, optional two-stage units, and hydraulic modulating units are supplied with a combination valve which includes:
 - a. Manual "A" valve
 - b. Manual "B" valve
 - c. Solenoid valve
 - d. Pilot safety
 - e. Pressure regulator
 Pipe directly in to combination valve (see Figure 10, p. 22).
5. A 1/8 in. N.P.T. plugged tapping, accessible for test gauge connection, must be installed immediately upstream of the gas supply connection to the appliance.
6. Provide a drip leg in the gas piping near the gas unit heater. A ground joint union and a manual gas shutoff valve should be installed ahead of the unit heater controls to permit servicing. The manual main shutoff valve must be located external to the jacket (see Figure 10, p. 22).
7. Make certain that all connections have been adequately doped and tightened.

NOTICE: **Overtightening!**

Do not overtighten the inlet gas piping into the valve. This may cause stresses that could crack the valve!

Note: Use pipe joint sealant resistant to the action of liquefied petroleum gases regardless of gas conducted.

⚠ WARNING **Hazard of Explosion!**

Never use an open flame to detect gas leaks. Explosive conditions may occur. Use a leak test solution or other approved methods for leak testing. Failure to follow recommended safe leak test procedures could result in death or serious injury or equipment or property-only-damage.

Figure 10. Pipe installation, standard controls

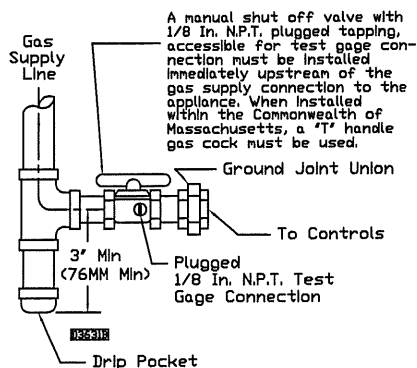

The appliance and its individual shutoff valve must be disconnected from the gas supply piping system during any pressure testing of that system at test pressures in excess of 1/2 psig (3.5 kPa).

The appliance must be isolated from the gas supply piping system by closing its individual manual shutoff valve during any pressure testing of the gas supply piping system at test pressures equal to or less than 1/2 psig (3.5 kPa).

Table 4. Gas piping requirements

Gas Type	Natural Gas	Propane (LP) Gas
Single Stage Gas Piping Requirements^(a)		
Manifold Pressure	3.5 in. wc (0.9 kPa)	10.0 in. wc (2.5 kPa)
Supply Inlet Pressure	14.0 in. wc Max. (3.5 kPa)	14.0 in. wc Max. (3.5 kPa)
	5.0 in wc Min. (1.2 kPa)	11.0 in wc Min. (2.7 kPa)
Two Stage Gas Piping Requirements^(b)		
Supply Inlet Pressure	6.5 in. wc Min. (1.6 kPa)	11.5 in. wc Min. (2.9 kPa)

(a) For single stage applications only, at normal altitudes.

(b) For two stage applications only, at normal altitudes.

Installation - Venting

Combustion Air Venting and Piping

WARNING!

Exhaust Fumes!

Each unit heater **MUST** have its own combustion air system and **MUST NOT** be connected to other air intake systems. To prevent exhaust fumes from being pulled into the air intake system or improper heating, ensure that the unit heater has its own combustion air system and is not connected to other air intake systems. Failure to follow these recommendations could result in death or serious injury or equipment damage.

WARNING

Carbon Monoxide!

Your venting system must not be blocked by any snow, snow drifts, or any foreign matter. Inspect your venting system to ensure adequate ventilation exists at all times! A blocked venting system could result in carbon monoxide poisoning. Symptoms of such condition include grogginess, lethargy, inappropriate tiredness, or flu-like symptoms. Failure to follow these recommendations could result in death or serious injury.

WARNING

Risk of Fire and Carbon Monoxide Poisoning with Improper Piping!

Never use pipe of a diameter other than that specified in Table 1, p. 11! To prevent pipe from melting and introducing exhaust fumes into the air supply, never use PVC, ABS or any other non-metallic pipe for venting! Failure to follow these recommendations could result in death or serious injury or equipment damage.

1. The combustion air system installation must be in accordance with the latest edition of (N.F.P.A. 54) ANSI Z223.1 National Fuel Gas Code. In Canada, installation must be in accordance with CGA-B149.1 "Installation Code for Natural Gas Burning Appliances and Equipment" and CGA-B149.2 "Installation Code for Propane Burning Appliances and Equipment".

Installation - Piping

2. A Breidert Type L or Fields inlet cap, furnished by the customer, must be installed at the termination point of the combustion air system (see Figure 11, p. 26 through Figure 14, p. 27).
Note: *The top of the inlet cap is to be no less than 12 inches (305 mm) from the top of the vent cap (see Figure 11, p. 26 through Figure 14, p. 27).*
3. Use single wall pipe constructed of 26 gauge galvanized steel or a material of equivalent durability and corrosion resistance for the combustion air system.
4. Long runs of single wall combustion air piping passing through an unheated space may require insulating if condensation becomes noticeable.
5. The combustion air system must be installed to prevent collection of condensate. Pitch horizontal pipes downward 1/4 inch per foot (21 mm/m) toward the inlet cap to facilitate drainage. Vertical combustion air pipes should be piped as depicted in Figure 11, p. 26.
6. The equivalent length of the vent air system must not be less than five feet (1.5 m) and must not exceed 50 feet (15.2 m). Equivalent length equals the total length of straight pipe, plus 10 feet (3.1 m) for each 90-degree elbow and five feet (1.5 m) for each 45-degree elbow.
Note: *For optimum performance, keep the combustion air system as straight as possible.*
7. Each slip joint must be secured with at least three corrosion resistant screws. Two full turns of 3M™ #425 Aluminum Foil Tape or its equivalent must then be used to seal each joint. General Electric RTV-108, Dow Corning® RTV-732 or an equivalent may be used instead of the tape.
8. For horizontal combustion air systems longer than five feet (1.5 m), the system must be supported from overhead building structures at three-foot (1-m) intervals.

Exhaust Venting

WARNING

Carbon Monoxide!

Never operate unit heaters without combustion air and flue gas piping in place. Each unit heater MUST have its own combustion air system and MUST NOT be connected to other vent systems or to a chimney. Your venting system must not be blocked by any snow, snow drifts, or any foreign matter. Inspect your venting system to ensure adequate ventilation exists at all times! Failure to follow these recommendations could result in death or serious injury.

WARNING

Risk of Fire and Carbon Monoxide Poisoning with Improper Piping!

Never use pipe of a diameter other than that specified in Table 1, p. 11! To prevent pipe from melting and introducing exhaust fumes into the air supply, never use PVC, ABS or any other non-metallic pipe for venting! Failure to follow recommendations could result in death or serious injury or equipment damage.

1. Vent system installation must be in accordance with the latest edition of (N.F.P.A. 54) ANSI Z223.1 National Fuel Gas Code. In Canada installation must be in accordance with CGA-B149.1 "Installation Code for Natural Gas Burning Appliances and Equipment" and CGA-B149.2 "Installation Code for Propane Burning Appliances and Equipment".
2. A Breidert Type L or Fields vent cap, furnished by the customer, must be installed at the termination point of the vent system (see Figure 11, p. 26 through Figure 14, p. 27).
3. Use single wall pipe constructed of 26 gauge galvanized steel or a material of equivalent durability and corrosion resistance for the vent system. For installations in Canada, use pipe constructed from 0.025-inch thick aluminum or 0.018-inch thick stainless steel".
4. Any run of single wall vent pipe passing through an unheated space must be insulated with an insulation suitable to 550°F (288°C).

5. The vent system must be installed to prevent collection of condensate. Pitch horizontal pipes downward 1/4 inch per foot (21 mm/m) toward the vent cap to facilitate drainage. Vertical vent pipes should be piped as depicted in Figure 11, p. 26.
6. The equivalent length of the vent system must not be less than five feet (1.5 m) and must not exceed 50 feet (15.2 m). Equivalent length equals the total length of straight pipe plus 10 feet (3.1 m) for each 90-degree elbow and five feet (1.5 m) for each 45-degree elbow.
7. Each slip joint must be secured with at least three corrosion resistant screws. Two full turns of 3M™ #425 Aluminum Foil tape or its equivalent must be used to seal each joint. General Electric RTV-108, Dow Corning® RTV-732, or an equivalent may be used instead of the tape.
8. For horizontal vent systems longer than five feet (1.5 m), the system must be supported from overhead building structures at three-foot (1-m) intervals.
9. The exhaust vent system must remain at a minimum distance of six inches (152 mm) from all combustible materials. Any part of the vent system that passes through a combustible material must be properly insulated.

For a VERTICAL vent pipe section that passes through a floor or roof, an opening four inches (102 mm) greater in diameter is required. The opening must be insulated and flashed in accordance with applicable installation codes.

A HORIZONTAL section of an exhaust vent system that passes through a combustible wall must be constructed and insulated as shown in Figure 14, p. 27.

10. The top of a VERTICALLY VENTED exhaust system must extend at least three feet (1 m) above the roof surface that it passes through. The point of termination for a HORIZONTALLY VENTED exhaust system must be at least 12 inches (305 mm) from the exterior of the wall that it passes through. In addition, the termination point must be at least three feet (1 m) above grade or above the snow line, more than six feet (2 m) from the combustion air inlet of another appliance, more than three feet (1 m) from any building opening, and more than three feet (1 m) from, and not directly above, any gas meter or service regulator (refer to Figure 13, p. 27 and Figure 14, p. 27).

Figure 11. Vertical intake/vent installation

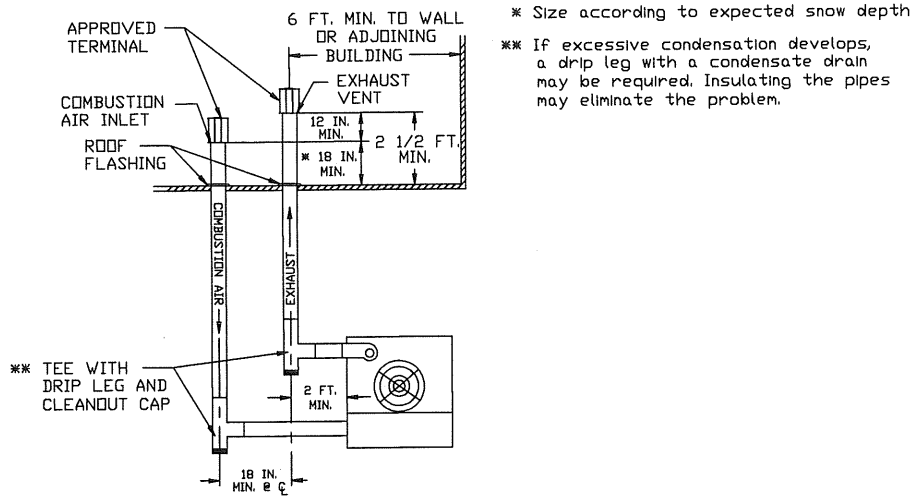

Figure 12. Vertical vent installation

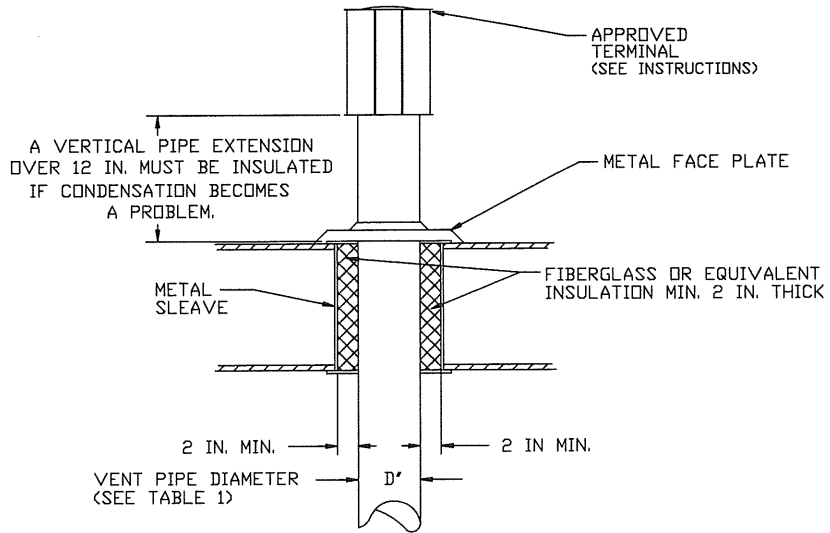

Figure 13. Horizontal intake/vent locations

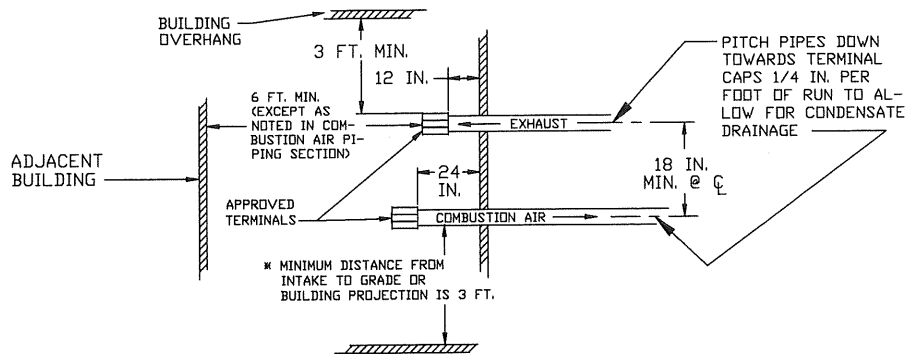
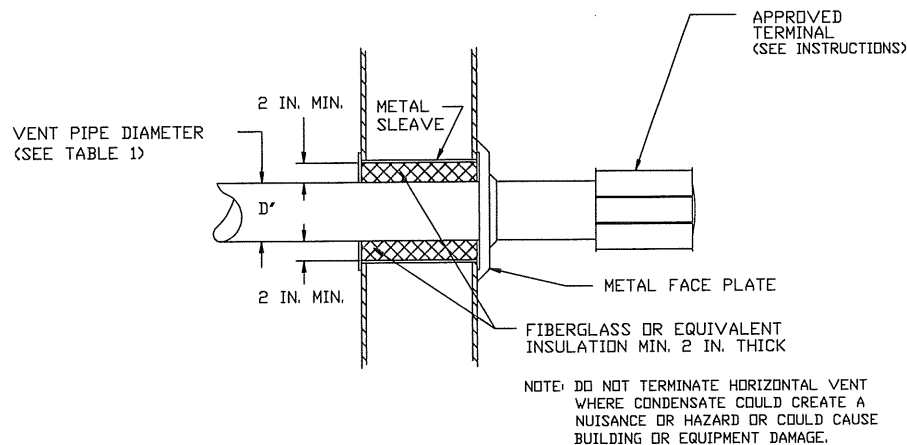

Figure 14. Horizontal vent installation



Installation - Concentric Vent Terminal

⚠ WARNING

Hazardous Service Procedures!

The maintenance and troubleshooting procedures recommended in this manual could result in exposure to electrical, mechanical or other potential safety hazards. Always refer to the safety warnings provided throughout this manual concerning these procedures. When possible, disconnect all electrical power including remote disconnect and discharge all energy storing devices such as capacitors before servicing. Follow proper lockout/tagout procedures to ensure the power can not be inadvertently energized. When necessary to work with live electrical components, have a qualified licensed electrician or other individual who has been trained in handling live electrical components perform these tasks. Failure to follow all of the recommended safety warnings provided, could result in death or serious injury.

Horizontal Termination

Select a location on an outside wall for the vent terminal. In most applications, the terminal should be on level with the flue outlet of the unit, less 1/4 inch per foot pitch for condensate drainage toward the outside of the building (see Figure 15, p. 28).

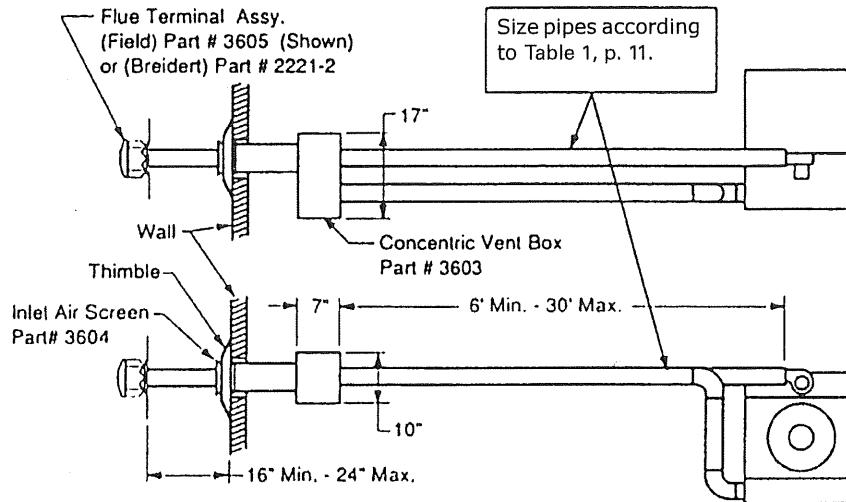
Figure 15. Horizontal concentric venting

The location of the vent terminal must be in accordance with the National Fuel Gas Code ANSI Z223.1 in the U.S. or the National Gas Installation Code CAN/CGA-B149.1 or the Propane Gas Installation Code CAN/CGA-149.2 in Canada. Minimum clearance are as follows:

Table 5. Horizontal concentric venting - minimum clearance

Object	Minimum Clearance	
	U.S.	Canada
Forced air inlet within 10 feet	3 feet above	6 feet
Door, window or gravity air inlet or combustion air inlet for other appliance	4 feet below 4 feet horizontally 1 foot above	12 inches for 100,000 Btu/h input or less, 3 feet for input exceeding 100,000 Btu/h.
Adjacent public walkways	7 feet above grade	7 feet above grade
Above grade level	1 foot	1 foot

In Canada, a vent shall not terminate above a meter/regulator assembly within 3 feet horizontally of the vertical center line of the regulator nor within 6 feet of any gas service regulator vent outlet.

Cut a hole through the wall for an 8-inch combustion air pipe. Install thimble if required by local codes or type of wall construction (see Figure 16, p. 29, Step 1).

Fasten a length of 5-inch pipe to the exhaust connection of the concentric adapter with sheet metal screws. Use at least three corrosion-resistant screws per joint. Seal all joints with high temperature silicone sealant. The concentric adapter box may be fastened directly to the wall or spaced away from the wall using suitable brackets (field-supplied). Before mounting the box, cut a length of 8-inch pipe so that it will protrude 2 inches through the wall when the box is mounted in position. Fasten the 8-inch pipe to the combustion air inlet connection of the concentric adapter and seal the joint. Add an additional 5-inch pipe, if necessary, so that the base of the exhaust cap will be 16 to 24 inches from the combustion air inlet (see Figure 16, p. 29, Step 2).

Insert the pipes through the wall and fasten the adapter box in place. Flash and/or caulk 8-inch pipe on outside wall (see Figure 16, p. 29, Step 3).

Install the inlet air screen on the 8-inch pipe and fasten with sheet metal screws. Install the flue terminal on the 5-inch pipe and fasten in place (see Figure 16, p. 29, Step 4).

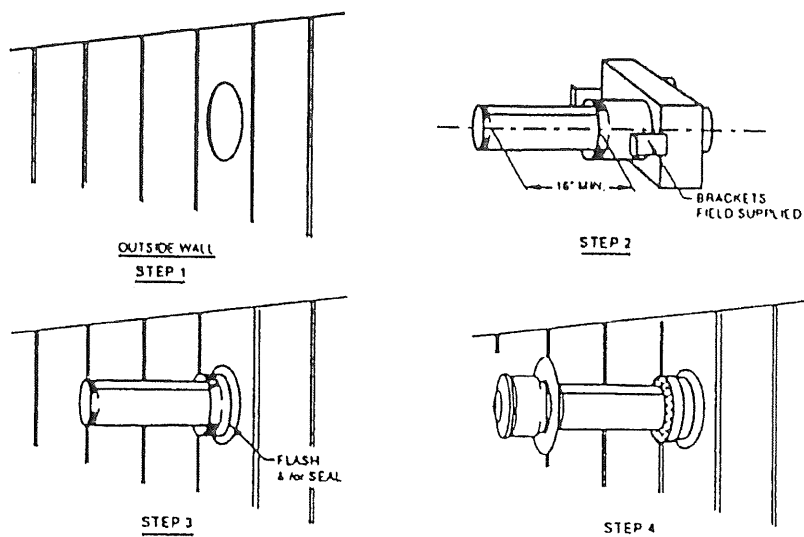
Figure 16. Horizontal concentric venting - installation

Connect the flue pipe and the combustion air pipe from the concentric adapter to the unit. The pipe must be single wall 26-gauge or heavier galvanized steel or a material of equivalent durability and corrosion resistance. The pipe diameter must be listed under inlet and flue size in Table 1, p. 11. The equivalent length of the exhaust vent pipe must be a minimum of 5 feet and a maximum of 50 feet. The equivalent length equals the total length of straight pipe plus 10 feet for each 90-degree elbow and 5 feet for each 45-degree elbow. Secure each joint with a minimum of three corrosion resistant screws. Seal all joints of the exhaust vent pipe with two full turns of 3M #425 Aluminum Foil Tape or its equivalent suitable for 550°F or high temperature silicone sealant. Seal all joints of the combustion air inlet pipe with two full turns of duct tape or aluminum foil tape or silicone sealant.

Vertical Termination

Select a location on the roof for the vent terminal, ensuring adequate space inside for the concentric vent box. The terminal must be at least 6 feet from any wall or adjoining building (see Figure 17, p. 30).

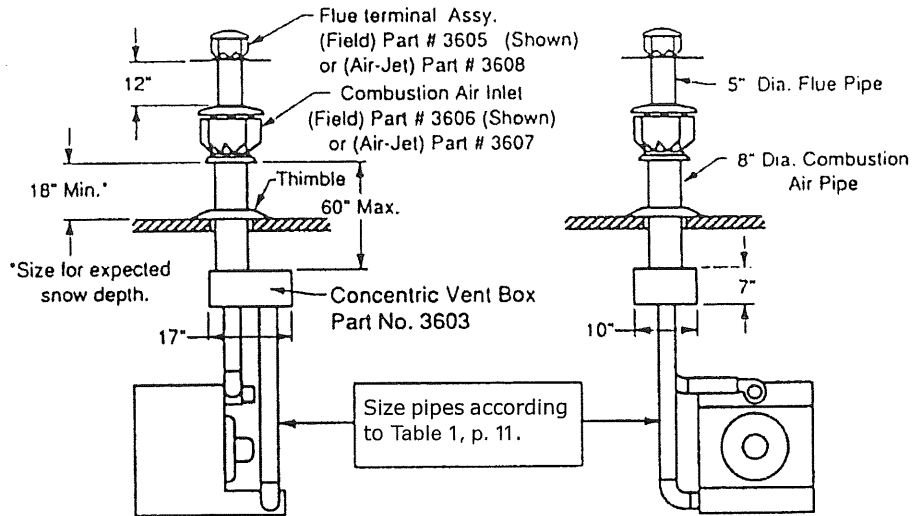
Figure 17. Vertical concentric venting

Cut a hole through the roof for an 8-inch combustion air pipe. Fasten a length of 5-inch pipe to the exhaust connection of the concentric adapter with sheet metal screws. Use at least three screws per joint. Seal all joints with high temperature silicone sealant. The concentric adapter box is to be suspended from the underside of the roof using suitable brackets (field-supplied). Before mounting the box, cut a length of 8-inch pipe so that dimension A (see Figure 18, p. 31, Step 1), is equal to the roof thickness plus 18 inches or the roof thickness plus the expected snow depth, whichever is greater. Fasten the 8-inch pipe to the combustion air inlet connection of the concentric adapter and seal the joint. Add an additional 5-inch pipe to extend at least 20 inches above the top of the 8-inch pipe.

Insert the pipe through the roof and fasten the adapter box in place (see Figure 18, p. 31, Step 2). Flash and/or caulk the 8-inch pipe to the roof (see Figure 18, p. 31, Step 3).

Install the inlet air cap on the 8-inch pipe and fasten with sheet metal screws. Install the flue terminal on the 5-inch pipe and fasten in place. Seal the joint between the 5-inch pipe and the inlet air cap with silicone sealant to prevent the entry of water (see Figure 18, p. 31, Step 4).

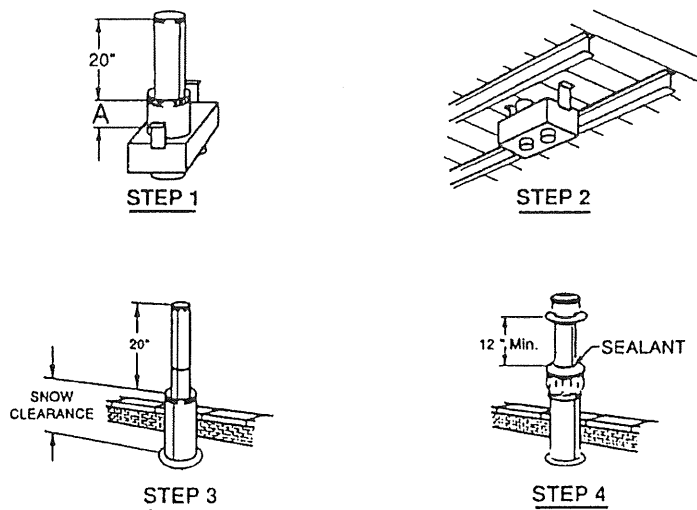
Figure 18. Vertical concentric venting - installation

Connect the flue pipe and the combustion air pipe from the concentric adapter to the unit. Pipe must be single wall 26-gauge or heavier galvanized steel or a material of equivalent durability and corrosion resistance. Pipe diameter must be as listed under inlet and flue size in Table 1, p. 11. The equivalent length of the exhaust vent pipe must be a minimum of 5 feet and a maximum of 50 feet. The equivalent length equals the total length of straight pipe plus 10 feet for each 90-degree elbow and 5 feet for each 45-degree elbow. Secure each joint with a minimum of three corrosion-resistant screws. Seal all joints of the exhaust vent pipe with two full turns of 3M #425 Aluminum Foil Tape or its equivalent suitable for 550°F or high temperature silicone sealant. Seal all joints of the combustion air inlet pipe with two full turns of duct tape or aluminum foil tape or silicone sealant. Do not enclose the exhaust vent pipe or run the pipe within 6 inches of combustible material.



Installation - Electrical

Electrical Connections

WARNING

Hazardous Service Procedures!

The maintenance and troubleshooting procedures recommended in this section of the manual could result in exposure to electrical, mechanical or other potential safety hazards. Always refer to the safety warnings provided throughout this manual concerning these procedures. When possible, disconnect all electrical power including remote disconnect and discharge all energy storing devices such as capacitors before servicing. Follow proper lockout/tagout procedures to ensure the power can not be inadvertently energized. When necessary to work with live electrical components, have a qualified licensed electrician or other individual who has been trained in handling live electrical components perform these tasks. Failure to follow all of the recommended safety warnings provided, could result in death or serious injury.

WARNING

Hazardous Voltage and Gas!

Turn off the gas supply and disconnect all electric power, including remote disconnects before servicing unit. Follow proper lockout/tagout procedures to ensure the power can not be inadvertently energized and the gas can not be inadvertently turned on. Failure to turn off gas or disconnect power before servicing could result in death or serious injury.

WARNING

Proper Field Wiring and Grounding Required!

All field wiring **MUST** be performed by qualified personnel. Improperly installed and grounded field wiring poses **FIRE & ELECTROCUTION** hazards. To avoid these hazards, you **MUST** follow requirements for field wiring installation and grounding as described in NEC and your local/state electrical codes. Failure to follow these requirements could result in death or serious injury.

Standard units are shipped for use on 115 volt, 60 hertz single phase electric power. The motor nameplate and electrical rating of the transformer should be checked before energizing the unit heater electrical system. All external wiring must conform to the latest edition of ANSI/NFPA No. 70 National Electrical Code and applicable local codes; in Canada, to the Canadian Electrical Code, Part 1 CSA Standard C22.1.

It is recommended that the electrical power supply to each unit heater be provided by a separate, fused, and permanently live electrical circuit. A disconnect switch of suitable electrical rating for each unit heater should be located as close to the gas valve and controls as possible. Each unit heater must be electrically grounded in accordance with the latest edition of the National Electric Code, ANSI/NFPA No. 70 or CSA Standard C22.1. Sample wiring connections are depicted in Figure 19, p. 33, Figure 24, p. 51, Figure 25, p. 52, Figure 26, p. 53, and Figure 27, p. 54.

The transformer supplied with this unit heater is internally fused. Any overload or short circuit will ruin the transformer.

Thermostat Wiring and Location

Note: *The thermostat must be mounted on a vertical, vibration-free surface, free from air currents, and in accordance with the furnished instructions.*

Mount the thermostat approximately 5 feet (1.5 m) above the floor in an area where it will be exposed to a free circulation of average temperature air. Always refer to the thermostat instructions as well as our unit wiring diagram, and wire accordingly. Avoid mounting the thermostat in the following locations:

1. Cold areas - Outside walls or areas where drafts may affect the operation of the control.

2. Hot areas - Areas where the sun's rays, radiation, or warm air currents may affect control operation.
3. Dead areas - Areas where air cannot circulate freely, such as behind doors or in corners.

Note: Thermostat wires tagged "W" and "G" must be connected together except when using a general purpose "SPDT" 24 Vac relay and a standard thermostat with subbase.

Figure 19. C1267G, thermostat wiring diagram

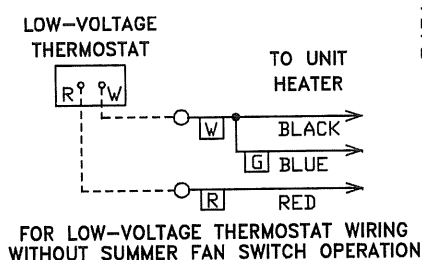

Thermostat Heat Anticipator Adjustments. The initial heat anticipator setpoint should equal the thermostat's current amperage draw when the unit is firing. This setpoint should be measured for the best results. Use the recommended ranges as a guide. If further information is needed, consult your thermostat manufacturer's instructions.

Recommended Heat Anticipator Setting Ranges:

25 ft. (7.6 m) T'stat Wiring	50 ft. (15.2 m) T'stat Wiring
0.85 to 0.90 A	0.90 to 1.1 A Max. Setting on T'stat

Fan Time Delay Control

Leads from the time delay controls are factory wired to the junction box. The fan control is a time delay relay (approximately 45 seconds ON, 65 seconds OFF). The fan control is rated at 17 amps.

Notes:

- The start-up fan delay must not exceed 90 seconds from a cold start.
- For all wiring connections, refer to the wiring diagram shipped with your unit (either affixed to the side jacket or enclosed in your unit's installation instruction envelope). Should any original wire supplied with the heater have to be replaced, it must be replaced with wiring material having a temperature rating of at least 105°C.

Should any high limit switch wires have to be replaced, they must be replaced with wiring material having a temperature rating of 200°C minimum.



Start-Up

NOTICE:

Equipment Damage!

Never operate the unit beyond the specified limits or severe damage to, and/or premature failure of, the unit could result!

Operation

Explanation of Controls (see Figure 20, p. 36)

⚠ WARNING

Carbon Monoxide!

Never operate unit heaters if the power venter is not operable. Your venting system must not be blocked by any snow, snow drifts, or any foreign matter. Inspect your venting system to ensure adequate ventilation exists at all times! Failure to follow these recommendations could result in death or serious injury due to Carbon Monoxide Poisoning (symptoms include grogginess, lethargy, inappropriate tiredness, or flu-like symptoms).

1. Each Separated Combustion Unit Heater comes equipped with a power vent system that consists of a power venter motor and blower, pressure switch, and sealed flue collector.

NOTICE:

Additional Devices!

The addition of external draft hoods or power venters is not permitted. Addition of such devices could cause severe unit malfunction or failure!

2. The power venter motor is energized by the room thermostat when a demand for heat is sensed. The pressure switch measures the pressure differential between the air inlet and exhaust vent systems. If the differential is correct, the indirect spark ignition system is energized.
3. The indirect spark ignition system consists of an ignition module, a dual combination valve, and a spark-ignited pilot burner. When the pressure switch is closed, the pilot valve opens as a spark is generated to light the pilot. When the flame is sensed by the flame sensing circuit, the spark ceases, and the main gas valve is opened to supply gas to the main burners. Once the thermostat has been satisfied, the vent system and gas valve are simultaneously de-energized, stopping all gas flow to the unit.
4. The limit switch interrupts the flow of electric current to the main gas valve if the unit heater becomes overheated.
5. The fan switch delays the operation of the fan is delayed for approximately 60–90 seconds once the thermostat is closed, and continues fan operation for approximately 60–90 seconds after the thermostat opens.

Note: The start-up fan delay must not exceed 90 seconds from a cold start.

6. The wall thermostat, supplied optionally, is a temperature sensitive switch that operates the vent and ignition systems to control the temperature of the space being heated.

Note: The thermostat must be mounted on a vertical, vibration-free surface, free from air currents, and in accordance with the furnished instructions.

Initial Lighting

1. Open the manual gas valve, in the gas supply line to the unit heater. Loosen the union in the gas supply line to purge it of air. Tighten the union and check for leaks.

⚠ WARNING**Hazard of Explosion!**

Never use an open flame to detect gas leaks. Explosive conditions may occur. Use a leak test solution or other approved methods for leak testing. Before attempting to light or relight the pilot, wait 5 minutes to allow gas which may have accumulated in the burner compartment to escape. Failure to follow recommended safe leak test procedures or pilot lighting/relighting instructions could result in death or serious injury or equipment or property-only-damage.

2. Turn on the electrical power. The unit heater should now be under the control of the thermostat. Set the thermostat to its highest setting; the power venter motor should start and burner ignition occur. Allow the unit heater to operate until the fan starts, then set the thermostat to its lowest setting. The burners and power venter motor should stop operating immediately while the fan continues to operate until the fan time delay times out, shutting it off. Reset the thermostat to the desired operational setting.

Start-Up

Figure 20. Burner components/unit controls (intermittent pilot ignition)

Burner Drawer Common Parts:

1. Main Burners
2. Burner Manifold
3. Air Shutters
4. Burner Springs
5. Main Burner Orifice
6. Transformer
7. Pilot Tubing

Controls (refer to "Wiring Diagrams," p. 51):

- 8A. Main Gas Valve (Honeywell)
- 8B. Main Gas Valve (White-Rodgers)
9. Honeywell Ignitor
10. Honeywell Pilot Burner
11. Honeywell Pilot Orifice
13. Hi Limit Switch (Located on Rear Header Plate of Heat Exchanger)

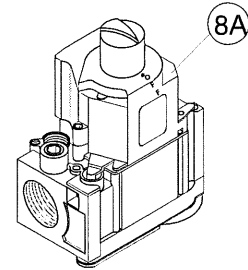
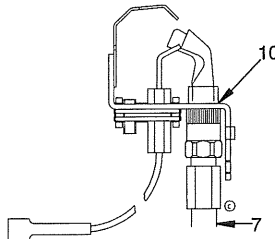
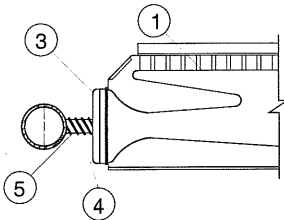
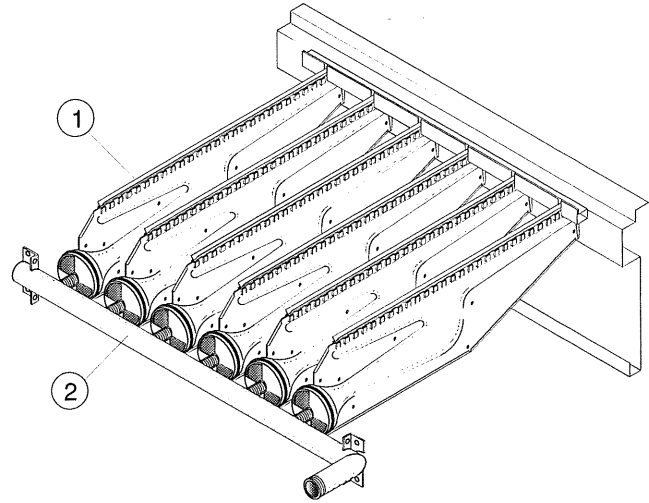

6

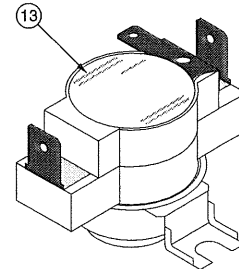
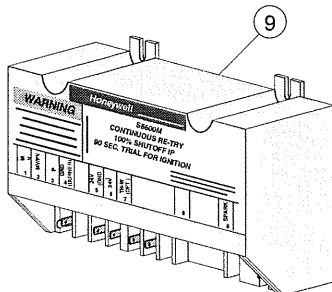
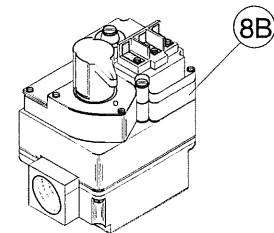
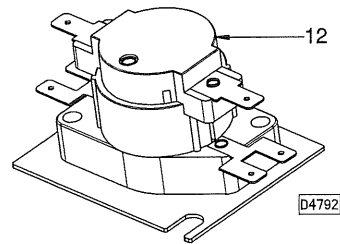
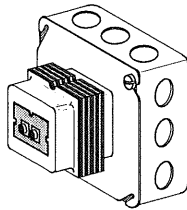

Checking Unit Heater Rate

NOTICE: **Overfiring!**

Never overfire the unit heater, as this could cause unsatisfactory operation, or shorten the life of the heater.

Gas appliances are rated based on sea level operation, with no adjustment required at elevations up to 2000 feet (610 m). At elevations above 2000 feet (610 m), input ratings should be reduced by 4 percent for each 1000 feet (305 m) above sea level. Check the input rate as follows:

1. Turn off all other gas appliances that utilize the same gas meter as the unit heater.
2. Let the unit heater run for 15 minutes.
3. Using the gas meter, clock the time that it takes to burn one cubic foot of gas (Heating Value).
4. Insert the time, in seconds, into the formula below:

$$\text{Input Rate} = \frac{\text{Heating Value (Btu/ft}^3\text{)} (3600 \text{ s/hr})}{\text{Time (s/ft}^3\text{)}}$$

Example: If the heating value = 1000 BTU/ft³ and the time/ft³ = 18 s/ft³ then

$$\text{Input Rate} = \frac{(1000 \text{ BTU/ft}^3) (3600 \text{ s/hr})}{18 \text{ s/ft}^3}$$

Input Rate = 200,000 BTU/hr

(Refer to "General Safety Information," p. 7 for metric conversions.)

Table 6. Main burner orifice schedule^(a)

Input in 1000 BTU ^(a)	Type of Gas	Natural		Propane		No. of Burner Orifices
		Heating Value	1075 BTU/ft ³ (40.1 MJ/m ³)	2500 BTU/ft ³ (93.1 MJ/m ³)		
		Manifold Pressure	3.5" wc (0.9 kPA)	10.5" wc (2.6 kPA)		
100	ft ³ /hr		96		40	4
	Orifice Drill		42		54	
125	ft ³ /hr		120		50	5
	Orifice Drill		42		54	
150	ft ³ /hr		140		60	6
	Orifice Drill		42		54	
175	ft ³ /hr		163		70	7
	Orifice Drill		42		54	
200	ft ³ /hr		186		80	8
	Orifice Drill		42		54	
225	ft ³ /hr		210		90	9
	Orifice Drill		42		54	
250	ft ³ /hr		233		100	10
	Orifice Drill		42		54	
300	ft ³ /hr		280		120	12
	Orifice Drill		42		54	
350	ft ³ /hr		326		140	14
	Orifice Drill		42		54	
400	ft ³ /hr		372		160	16
	Orifice Drill		42		54	

Note: When installed in Canada, any references to deration at altitudes in excess of 2000 feet (610 m) are to be ignored. At altitudes of 2000 to 4500 feet (610 to 1372 m), the unit heaters must be orificed to 90 percent of the normal altitude rating, and be so marked in accordance with the CGA certification.

(a) This schedule is for units operating at normal altitudes of 2000 feet (610 m) or less. SPECIAL ORIFICES ARE REQUIRED FOR INSTALLATIONS ABOVE 2,000 FEET (610 m).

Primary Air Shutter Adjustment

After the unit has been operating for at least 15 minutes, adjust the primary air flow to the burners. Turn the friction-locked, manually-rotated air shutters clockwise to close, or counterclockwise to open (see Figure 20, p. 36 and Figure 2, p. 9).

For correct air adjustment, close the air shutter until yellow tips in the flame appear. Then open the air shutter to the point just beyond the position where yellow tipping disappears. Refer to Figure 21.

Note: There may be momentary and spasmodic orange flashes in the flame. This is caused by the burning of airborne dust particles, and should not be confused with the yellow tipping, which is a stable or permanent situation when there is insufficient primary air.

Figure 21. Main burner flames

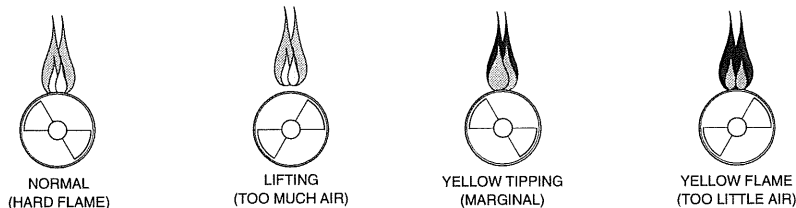

Pilot Adjustment

1. Remove the pilot adjustment cap.
2. Adjust the pilot screw to provide a properly sized flame.
3. A proper pilot flame is a soft steady flame that envelops 3/8- to 1/2-inch (9.5 to 12.7 mm) of the thermocouple .
4. Replace the pilot adjustment cap.

Manifold Pressure Adjustment

If the manifold pressure requires minor adjustment, remove the cap from the pressure regulator and turn the adjustment screw clockwise to increase the pressure, or counterclockwise to decrease the pressure. The adjusted manifold pressure should not vary more than 10 percent from the pressures specified in Table 6, p. 38.



Start-Up

Gas Equipment Start-Up

Customer _____ Job Name & Number _____

Pre-Inspection Information with Power and Gas Off

Type of Equip: Indoor Unit Heater

Serial Number: _____ Model Number: _____

Name Plate Voltage: _____ Name Plate Amperage: _____

Type of Gas: Natural LP Tank Capacity: _____ lb Rating: _____ Btu @ _____ °F
_____ kg _____ kW @ _____ °C

- Are all panels, doors, vent caps in place?
- Has the unit suffered any external damage? Damage _____
- Does the gas piping and electric wiring appear to be installed in a professional manner?
- Has the gas and electric been inspected by the local authority having jurisdiction?
- Is the gas supply properly sized for the equipment?
- Were the installation instructions followed when the equipment was installed?
- Have all field installed controls been installed?
- Do you understand all the controls on this equipment? **If not, contact your wholesaler or rep. (DO NOT START this equipment unless you fully understand the controls.)**

GENERAL

With power and gas off.

- Make certain all packing has been removed.
- Tighten all electrical terminals and connections.
- Check damper linkages for tightness.
- Check all fans & blowers for free movement.
- Check all controls for proper settings.
- Check all set screws on blowers and bearings.
- Check belt tightness.

BLOWER

With power on and gas off.

- Check voltage L1 _____ L2 _____ L3 _____
- Check rotation of main blower.
- Check motor amps L1 _____ L2 _____ L3 _____
- Blower RPM _____
- Check air filters. (Record quantity & size.)

GAS HEATING

With power and gas on.

- Inlet gas pressure. _____ in. wc or _____ kPa
- Pilot & main burner ignition.
- Manifold gas pressure. _____ in. wc or _____ kPa
- Cycle on HIGH LIMIT
- Cycle firestat and/or freezestat.
- Check electronic modulation. Set at: _____
- Cycle and check all other controls not listed.
- Check operation of remote panel.
- Entering air temp. _____ °F or _____ °C
- Discharge air temp. (high fire) _____ °F. or _____ °C
- External static pressure _____ in. wc
- Cycle by thermostat or operating control.

Remarks: _____

Maintenance

WARNING

Hazardous Service Procedures!

The maintenance and troubleshooting procedures recommended in this section of the manual could result in exposure to electrical, mechanical or other potential safety hazards. Always refer to the safety warnings provided throughout this manual concerning these procedures. When possible, disconnect all electrical power including remote disconnect and discharge all energy storing devices such as capacitors before servicing. Follow proper lockout/tagout procedures to ensure the power can not be inadvertently energized. When necessary to work with live electrical components, have a qualified licensed electrician or other individual who has been trained in handling live electrical components perform these tasks. Failure to follow all of the recommended safety warnings provided, could result in death or serious injury.

Periodic Service

All Maintenance/Service information should be recorded accordingly on the inspection sheet provided in this manual (see "Gas Equipment Start-Up," p. 40).

Note: *The heater and vent system should be checked once a year by a qualified technician.*

WARNING

Hazardous Voltage and Gas!

Turn off the gas supply and disconnect all electric power, including remote disconnects before servicing unit. Follow proper lockout/tagout procedures to ensure the power can not be inadvertently energized and the gas can not be inadvertently turned on. Failure to turn off gas or disconnect power before servicing could result in death or serious injury.

Important: *Gas tightness of the safety shut-off valves must be checked on at least an annual basis.*

WARNING

Hazard of Explosion!

Never use an open flame to detect gas leaks. Explosive conditions may occur. Use a leak test solution or other approved methods for leak testing. Failure to follow recommended safe leak test procedures could result in death or serious injury or equipment or property-only-damage.

To check gas tightness of the safety shut-off valves, turn off the manual valve upstream of the appliance combination control. Remove the 1/8-inch pipe plug on the inlet side of the combination control and connect a manometer to that tapping. Turn the manual valve on to apply pressure to the combination control. Note the pressure reading on the manometer, then turn the valve off. A loss of pressure indicates a leak. If a leak is detected, use a soap solution to check all threaded connections. If no leak is found, combination control is faulty and must be replaced before putting appliance back in service.

Should maintenance be required, perform the following inspection and service routine:

1. Inspect the area near the unit to be sure that there is no combustible material located within the minimum clearance requirements listed in this manual.

WARNING

Combustible Materials!

Maintain proper clearance between the unit heat exchanger, vent surfaces and combustible materials. Refer to unit nameplate and installation instructions for proper clearances. Improper clearances could result in a fire hazard. Failure to maintain proper clearances could result in death or serious injury or property damage.

2. Turn off the manual gas valve and electrical power to the gas unit heater.
3. To clean or replace the main burners, remove the bottom panel and compress the spring by moving the burner toward the manifold. Slide the opposite end of the burner downward from the locating slot while retaining spring is still compressed. Pull the burners away from the heat.
4. With the burners removed, wire brush the inside surfaces of the heat exchanger.
5. Remove any dirt, dust, or other foreign matter from the burners using a wire brush and/or compressed air. Ensure that all parts are unobstructed. Inspect and clean pilot burner if necessary.
6. Reassemble the gas unit heater by replacing all parts in reverse order.
7. Relight the pilot (see lighting instruction plate on the unit). Complete the appropriate unit start-up procedure as given in "Operation," p. 34.
8. Check the burner adjustment (see "Primary Air Shutter Adjustment," p. 38).
9. Check all gas control valves and pipe connections for leaks.
10. Check the operation of the automatic gas valve by lowering the setting of the thermostat, stopping the operation of the gas unit heater. The gas valve should close tightly, completely extinguishing the flame on the main burners.
11. Inspect and service the motor/fan assemblies. To maintain efficient air flow, inspect and clean the fan blades and guard to prevent buildup of foreign matter.
12. Check lubrication instructions on the motor. If oiling is required, add 3 to 4 drops of electric motor oil as follows:
 - a. Light Duty - After 3 years or 25,000 hours of operation.
 - b. Average Duty - Annually after 3 years or 8,000 hours of operation.
 - c. Heavy Duty - Annually after 1 year or at least every 1,500 hours of operation.

NOTICE:**Equipment Damage!**

Never over oil the motor or premature failure could occur!

13. Check and test the operational functions of all safety devices supplied with your unit.

Figure 22. Power venter assembly

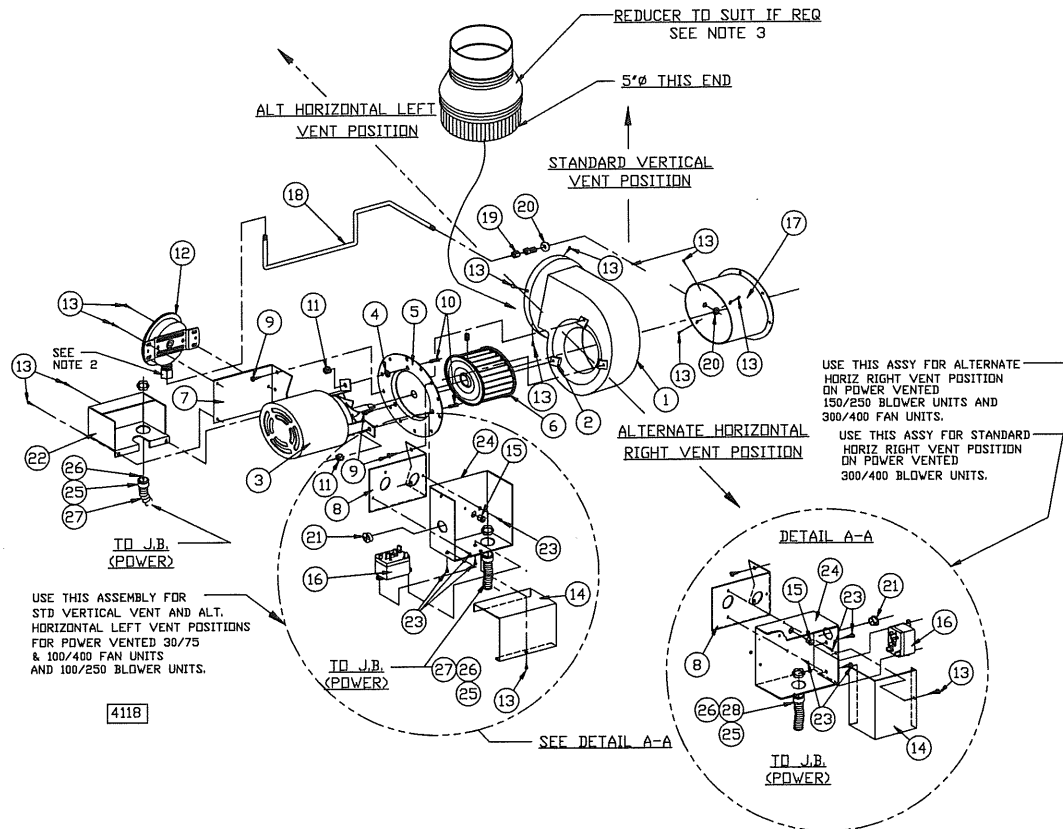

Ref. No.	Description	Ref. No.	Description
1	Blower Housing Assembly	15	Snap Bushing
2	Speed Nut	16	Relay (Motor)
3	Motor	17	Draftor Stack Assembly
4	Washer, Plain	18	Tubing (Aluminum) Formation
5	Plate Adapter	19	Male Connector
6	Blower Wheel (see Note 1)	20	Locknut
7	Mounting Bracket (Pressure Switch)	21	Hole Plug
8	Mounting Bracket (Junction Box)	22	Pressure Switch Cover
9	Screw, S.T.	23	Drill Screw
10	Screw, Machine (L = 3/4")	24	Junction Box Base
11	Nut, Keps (Ext. Lock Washer)	25	Purge Relay (not shown) - located in Junction Box
12	Air Pressure Switch		
13	Drill Screw		
14	Junction Box Cover		

Notes:

- For item No. 6, use counter-clockwise rotation.
- DO NOT OVERTIGHTEN CELCON NUT! HAND TIGHTEN ONLY! DO NOT USE TOOLS! Approximate 1/3 turn maximum or 8 inch pounds is sufficient from the point where the tube does not slip in or out.
- Flue Sizes:
 100/175 units: 4" dia. flue outlet Reducer required - To be supplied by installer.
 200/250 units: 5" dia. flue outlet (no adapter required).
 300/400 units: 6" dia. flue outlet Increaser required - To be supplied by manufacturer.

Installation Instructions for Field Replacement of Power Venter Motor

Important: This replacement must be performed only by a qualified technician.

Note: All hardware (screws, nuts, washers) that will be removed from the unit will be reused for this motor replacement. **DO NOT LOSE ANY OF THESE PARTS.**

Figure 23. Identification of parts

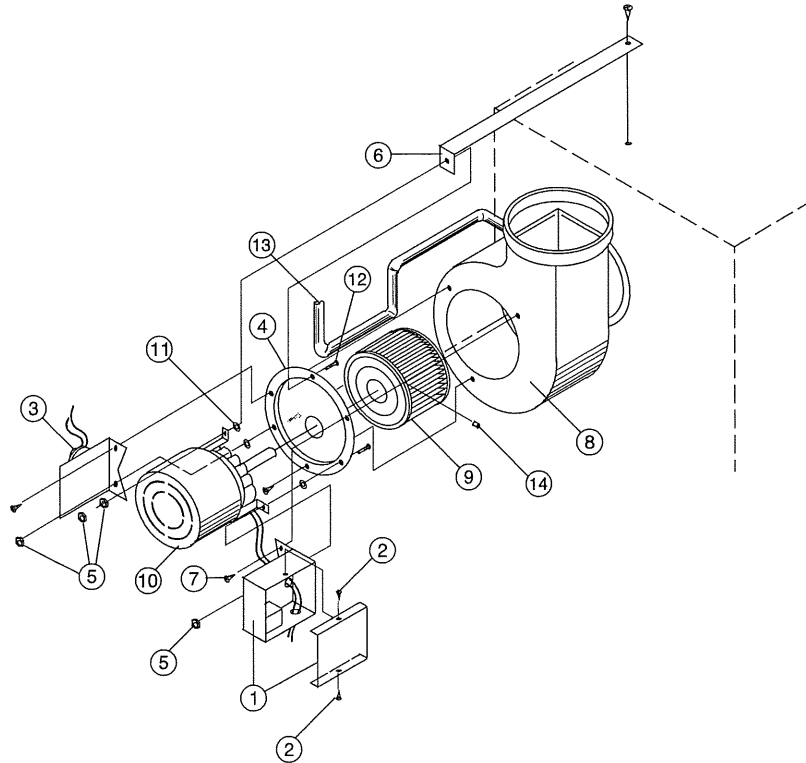

Ref. No.	Description
1	Relay Junction Box/Mounting Bracket Assembly
2	#8 Drill Screws (2 required)
3	Pressure/Mounting Bracket Assembly
4	Mounting Plate Adapter
5	Keps Nut w/External Tooth Lockwasher (4 required)
6	Motor Support Shipping Bracket
7	Phillips Head Screws (3 required)
8	Power Venter Blower Housing
9	Blower Wheel
10	Motor
11	Space Washers (3 required)
12	Machine Screw (3 required)
13	Sensing Tube
14	Set Screw

Tools and Parts Needed

Wire Stripper and Crimper; Slotted Head and #2 Phillips Head Screwdriver; 3/8" Wrench; 1/8" Allen Wrench (long handle); marker; (1) 1/4" push on terminal for Wire.

Notes:

- *Remove the cover from the Relay Junction Box (Item 1) by removing two screws (Item 2) top and bottom. Disconnect both wires from the motor lead ends. One is connected to terminal #4 on the venter relay, and the other is connected with a wire nut to a black wire.*
- *Remove the sensing tube (Item 3) from the Pressure Switch/Mounting Bracket (Item 3) at motor end only. Separated Combustion Units: Remove both tubes at motor end only - note location.*
- *Mark locations of the Relay Junction Box and Pressure Switch Mounting Brackets along with the Motor (Item 10) mounts on the Mounting Adapter Plate (Item 4) - using a marker.*
- *Remove nut (Item 5) that secures the Motor Support Shipping Bracket (Item 6) to the Mounting Adapter Plate. Pull this bracket away from the Motor Mounting Adapter Plate.*
- *Remove three phillips head screws (Item 7) on the Motor mounting Adapter Plate. Remove the Motor/Blower Wheel/Adapter Plate assembly from the Power Venter Blower Housing (Item 8).*
- *Remove the Blower Wheel (Item 9) from the motor shaft - by removing the set screw (Item 14) using a 1/8" Allen Wrench.*
- *Remove the three Motor Mounting Nuts (Item 5), Space Washers (Item 11), and Screws (Item 12). Do not lose these parts! Using caution - the motor will disengage from the Mounting Adapter Plate, along with the Relay Junction Box and Pressure Switch Mounting Brackets will also disengage.*
- *Reverse order to install the new Power Venter Motor.*
- **TEST FIRE THE UNIT FOR A FEW CYCLES, MAKING SURE THAT THE UNIT IS OPERATING SATISFACTORILY.**

How to Order Replacement Parts

Please send the following information to your local Parts center; If further assistance is needed, contact the manufacturer's customer service department.

- Model number
- Serial Number
- Part description and Number as shown in the Replacement Parts Catalog.



Diagnostics

Troubleshooting

⚠️ WARNING

Hazardous Service Procedures!

The maintenance and troubleshooting procedures recommended in this section of the manual could result in exposure to electrical, mechanical or other potential safety hazards. Always refer to the safety warnings provided throughout this manual concerning these procedures. When possible, disconnect all electrical power including remote disconnect and discharge all energy storing devices such as capacitors before servicing. Follow proper lockout/tagout procedures to ensure the power can not be inadvertently energized. When necessary to work with live electrical components, have a qualified licensed electrician or other individual who has been trained in handling live electrical components perform these tasks. Failure to follow all of the recommended safety warnings provided, could result in death or serious injury.

Table 7. Troubleshooting guide

Symptoms	Possible Cause(s)	Corrective Action
A. Flame lifting from burner ports.	<ol style="list-style-type: none"> 1. Pressure regulator set too high. 2. Defective regulator. 3. Burner orifice too large. 	<ol style="list-style-type: none"> 1. Reset manifold pressure. Refer to "Operation," p. 34. 2. Replace regulator section of combination gas valve or complete valve. 3. Check with local gas supplier for proper orifice size and replace. Refer to "Operation," p. 34.
B. Flame pops back.	<ol style="list-style-type: none"> 1. Excessive primary air. 2. Burner orifice too small. 	<ol style="list-style-type: none"> 1. Close air shutter. Refer to "Operation," p. 34. 2. Check with local gas supplier for proper orifice size and replace. Refer to "Operation," p. 34.
C. Noisy flame.	<ol style="list-style-type: none"> 1. Too much primary air. 2. Noisy pilot. 3. Irregular orifice causing whistle or resonance. 4. Excessive gas input. 	<ol style="list-style-type: none"> 1. Close air shutter. 2. Reduce pilot gas. Refer to "Operation," p. 34. 3. Replace orifice. 4. Reset manifold pressure. Refer to "Operation," p. 34; Replace regulator section of combination gas valve or complete valve; or check with local gas supplier for proper orifice size and replace. Refer to "Operation," p. 34.
D. Yellow tip flame (some yellow tipping on propane gas is permissible).	<ol style="list-style-type: none"> 1. Insufficient primary air. 2. Clogged main burner ports. 3. Misaligned orifices. 4. Clogged flue collector. 5. Air shutter linted. 6. Insufficient combustion air. 	<ol style="list-style-type: none"> 1. Open air shutters. Refer to "Operation," p. 34. 2. Clean main burner ports. 3. Replace manifold assembly. 4. Clean flue collector. 5. Check for dust or lint at air mixer opening and around the air shutter. 6. Clean combustion air inlet openings in bottom panel; see "Installation - Piping," p. 20.
E. Floating flame.	<ol style="list-style-type: none"> 1. Blocked venting. 2. Insufficient combustion air. 3. Blocked heat exchanger. 4. Air leak into combustion chamber or flue collector. 	<ol style="list-style-type: none"> 1. Clean flue. Refer to "Installation - Piping," p. 20. 2. Clean combustion air inlet openings in bottom panel; see "Installation - Piping," p. 20. 3. Clean heat exchanger. 4. Determine cause and repair accordingly.

Table 7. Troubleshooting guide (continued)

Symptoms	Possible Cause(s)	Corrective Action
F. Gas Odor.	1. Shut off gas supply immediately!	1. Inspect all gas piping and repair.
	2. Blocked heat exchanger/venting.	2. Clean heat exchanger/flue.
	3. Drafts around heater.	3. Eliminate drafts. Refer to "Installation - Mechanical," p. 13.
	4. Negative pressure in building.	4. See "Installation - Piping," p. 20.
	5. Blocked flue collector.	5. Clean flue collector.
G. Delayed ignition.	1. Excessive primary air.	1. Close air shutter. Refer to "Operation," p. 34.
	2. Main burner ports clogged near pilot.	2. Clean main burner ports.
	3. Pressure regulator set too low.	3. Reset manifold pressure. Refer to "Operation," p. 34.
	4. Pilot decreases in size when main burners come on.	4. Supply piping is inadequately sized. Refer to "Installation - Piping," p. 20.
	5. Pilot flame too small.	5. Clean pilot orifice. Refer to "Operation," p. 34.
	6. Drafts around heater.	6. Eliminate drafts. Refer to "Installation - Mechanical," p. 13.
	7. Improper venting.	7. Refer to "Installation - Piping," p. 20.
H. Failure to ignite.	1. Main gas off.	1. Open all manual gas valves.
	2. Lack of power at unit.	2. Replace fuse or turn on power supply.
	3. Thermostat not calling for heat.	3. Turn up thermostat.
	4. Defective limit switch.	4. Check limit switch with continuity tester. If open, replace limit switch.
	5. Improper thermostat or transformer wiring.	5. Check wiring per diagrams.
	6. Defective gas valve.	6. Replace gas valve.
	7. Defective thermostat.	7. Check thermostat and replace if defective.
	8. Defective transformer.	8. Be sure 115 volts is supplied to the transformer primary, then check for 24 volts at secondary terminal before replacing.
	9. Loose wiring.	9. Check and tighten all wiring connections per diagrams.
	10. Defective ignition control.	10. Replace, if necessary. Also see U, V, and W symptoms.
I. Condensation of water vapor.	1. Improper venting	1. Refer to "Installation - Venting," p. 23.
J. Burner won't turn off.	1. Poor thermostat location.	1. Relocate thermostat away from drafts.
	2. Defective thermostat.	2. Replace thermostat.
	3. Improper thermostat or transformer wiring at gas valve.	3. Check wiring per diagrams.
	4. Short circuit.	4. Check operation at valve. Check for short (such as staples piercing thermostat wiring), and correct.
	5. Defective or sticking gas valve.	5. Replace gas valve.
	6. Excessive gas supply pressure.	6. Refer to "Installation - Piping," p. 20.



Diagnostics

Table 7. Troubleshooting guide (continued)

Symptoms	Possible Cause(s)	Corrective Action
K. Rapid burner cycling.	1. Loose electrical connections at gas valve or thermostat.	1. Tighten all electrical connections.
	2. Excessive thermostat heat anticipator.	2. Adjust thermostat heat anticipator for longer cycles. Refer to "Installation - Electrical," p. 32.
	3. Unit cycling on high limit.	3. Check for proper air supply across heat exchanger.
	4. Poor thermostat location.	4. Relocate thermostat. (Do not mount thermostat on unit).
	5. Draft on pilot.	5. Eliminate drafts. Refer to "Installation - Mechanical," p. 13.
	6. Defective ignitor control.	6. Replace ignitor.
	7. Defective high limit switch.	7. Jumper high limit switch terminals 1 and 2. If burner operates normally, replace switch.
L. Noisy.	1. Fan blades loose.	1. Replace or tighten.
	2. Fan blades dirty.	2. Clean fan wheel.
	3. Vibration isolators deteriorated.	3. Replace vibration isolators.
	4. Bearings are dry.	4. Oil bearings on fan motor. (Refer to label on motor.)
M. Pilot will not light or will not stay lit.	1. Main gas off.	1. Open all manual gas valves.
	2. Pilot adjustment screw turned too low on combination/automatic main gas valve.	2. Refer to "Operation," p. 34.
	3. Air in gas line.	3. Purge air from gas supply.
	4. Incorrect lighting procedure.	4. Follow lighting instruction label adjacent to gas valve.
	5. Dirt in pilot orifice.	5. Remove pilot orifice. Clean with compressed air or solvent. (Do not ream.)
	6. Extremely high or low gas pressure.	6. Refer to "Operation," p. 34.
	7. Defective thermocouple.	7. Check thermocouple connection, and replace if defective.
	8. Drafts around unit.	8. Eliminate drafts. Refer to "Installation - Mechanical," p. 13.
	9. Pilot valve not opening (faulty wiring).	9. Inspect and correct all wiring.
	10. No spark (faulty wiring).	10. Inspect and correct ignition system wiring. See symptoms U, V, and W.
	11. Defective gas valve.	11. Replace.
N. Fan will not run.	1. Loose wiring.	1. Check and tighten all wiring connections per diagrams. Thermostat wires tagged "W" and "G" must be connected together (unless special thermostats are used; if so, see thermostat wiring diagram, "Electrical Connections," p. 32).
	2. Defective motor overload protector or defective motor.	2. Replace motor.
	3. Defective fan switch.	3. Check for 24V across "H" terminals on fan time delay switch. If 24V is present, jumper terminals numbered 2 and 4. If motor runs, the fan switch is defective and must be replaced. If 24V is not present, check wiring per diagrams.
O. Fan motor turns on and off while burner is operating.	1. Fan switch heater element improperly wired.	1. Be sure fan switch heater terminals are connected per diagrams.
	2. Defective fan switch.	2. Replace fan switch.
	3. Motor overload protector cycling on and off.	3. Check motor amps against motor name plate rating, check voltage, replace fan motor if defective.
	4. Motor not properly oiled.	4. Refer to label on motor.

Table 7. Troubleshooting guide (continued)

Symptoms	Possible Cause(s)	Corrective Action
P. Fan motor will not stop.	<ol style="list-style-type: none"> 1. Improperly wired fan control. 2. Main burners not lighting while thermostat calls for heat. 3. Defective fan switch. 	<ol style="list-style-type: none"> 1. Check all wiring. 2. Refer to H and N symptoms. 3. Replace fan switch.
Q. Not enough heat.	<ol style="list-style-type: none"> 1. Incorrect gas input. 2. Heater undersized. 3. Thermostat malfunction. 4. Heater cycling on limit control. 	<ol style="list-style-type: none"> 1. Refer to "Operation," p. 34. 2. This is especially true when the heated space is enlarged. Have the heat loss calculated and compare to the heater output (80 percent of input). Your gas supplier or installer can furnish this information. If heater is undersized, add additional heaters. 3. Replace thermostat. 4. There should be NO ducts attached to the front of this heater. Check air movement through heat exchanger. Check voltage to fan motor. Clean fan blade and heat exchanger and oil fan motor.
R. Too much heat.	<ol style="list-style-type: none"> 1. Thermostat malfunction. 2. Heater runs continuously. 	<ol style="list-style-type: none"> 1. Replace thermostat. 2. Check wiring per diagrams; check operation at valve. Look for short (such as staples piercing thermostat wiring), and correct; replace gas valve. Refer to "Operation," p. 34.
S. Cold air is delivered on start up.	<ol style="list-style-type: none"> 1. Fan switch heater element improperly wired. 	<ol style="list-style-type: none"> 1. Be sure fan switch heater terminals are connected per diagrams.
T. Cold air is delivered during heater operation.	<ol style="list-style-type: none"> 1. Incorrect manifold pressure or input. 2. Voltage to unit too high. 3. Air throughput too high. 	<ol style="list-style-type: none"> 1. Refer to "Operation," p. 34. 2. Check motor voltage with fan running. Should be 115 volts AC. 3. Refer to "Operation," p. 34.
U. No Spark.	<ol style="list-style-type: none"> 1. Thermostat not calling for heat. 2. No low voltage. 3. Spark gap closed or too wide. 4. Broken or cracked ceramic on spark electrode. 	<ol style="list-style-type: none"> 1. Close thermostat contacts. 2. Check for 24V across 24V terminals of S8600. 3. Set gap to 0.1. 4. Replace pilot assembly.
V. Spark present but pilot does not light.	<ol style="list-style-type: none"> 1. Loose S8600 connections. 2. Improper gas pressure. 3. Is spark in pilot gas stream? 4. No pilot gas — do not use match to test - presence of gas is easily detected by the odor. 	<ol style="list-style-type: none"> 1. Check all connections, term. PV feeds 24V to pilot valve. 2. Check pressure—pressure that is either too high or too low may cause a problem. 3. Spark should arc from electrode. 4. Check pilot line for kinks. Ensure there are no drafts.
W. Pilot lights — Main valve does not energize.	<ol style="list-style-type: none"> 1. Loose S8600 connections. 2. Cracked or broken sensor ceramic. 3. Check sensor/spark lead for continuity. 4. Measure 24 volts from term. MV to term. MV/PV. 	<ol style="list-style-type: none"> 1. Check connections-term. MV feeds main valve. 2. Replace pilot assembly. 3. Replace if needed. 4. If present, replace main valve; if not, replace S8600 Igniter.
X. Hi-Limit switch tripping	<ol style="list-style-type: none"> 1. Vertical run of flue is too short. 2. Unit is overfiring. 3. Air flow too low. 4. Defective switch. 	<ol style="list-style-type: none"> 1. Lengthen vertical run of flue pipe (see "Installation - Venting," p. 23). 2. Burner orifice may be too large: verify/replace if required. 3. Increase air flow; check fan size. Check for proper voltage. 4. Replace.



Diagnostics

Table 7. Troubleshooting guide (continued)

Symptoms	Possible Cause(s)	Corrective Action
Y. Noisy power venter.	<ol style="list-style-type: none">1. Power venter wheel loose.2. Power venter wheel dirty.3. Power venter wheel rubbing housing.4. Bearings are dry.	<ol style="list-style-type: none">1. Replace or tighten.2. Clean power venter wheel.3. Realign power venter wheel.4. Oil bearings on power venter motor. (Refer to label on motor).
Z. Power venter will not run.	<ol style="list-style-type: none">1. Loose wiring.2. Defective motor overload protector or defective motor.3. Defective power venter relay.	<ol style="list-style-type: none">1. Check and tighten all wiring connections per diagrams. Thermostat wires tagged "W" and "G" must be connected together (unless special thermostats are used; if so see thermostat wiring diagram, "Electrical Connections," p. 32).2. Replace motor.3. Check for 24V across 1 and 3 terminals on fan relay. If 24V is present, jumper terminals numbered 2 and 4. If motor runs, the relay is defective and must be replaced. If 24V is not present, check wiring per diagrams.
AA. Power venter motor turns on and off while burner is operating.	<ol style="list-style-type: none">1. Fan relay heater element improperly wired.2. Defective venter relay switch.3. Motor overload protector cycling on and off.4. Motor not properly oiled.	<ol style="list-style-type: none">1. Be sure relay heater terminals are connected per diagrams.2. Replace venter relay.3. Check motor amps against motor name plate rating, check voltage; replace power venter motor if defective.4. Refer to label on motor.
AB. Power venter motor will not stop.	<ol style="list-style-type: none">1. Improperly wired venter relay.2. Main burner not lighting while thermostat calls for heat.3. Defective venter relay.	<ol style="list-style-type: none">1. Check all wiring.2. Refer to H and N symptoms.3. Replace venter relay.

Wiring Diagrams

Figure 24. Separated combustion unit, 100-400 blower, 100-250 prop. fan

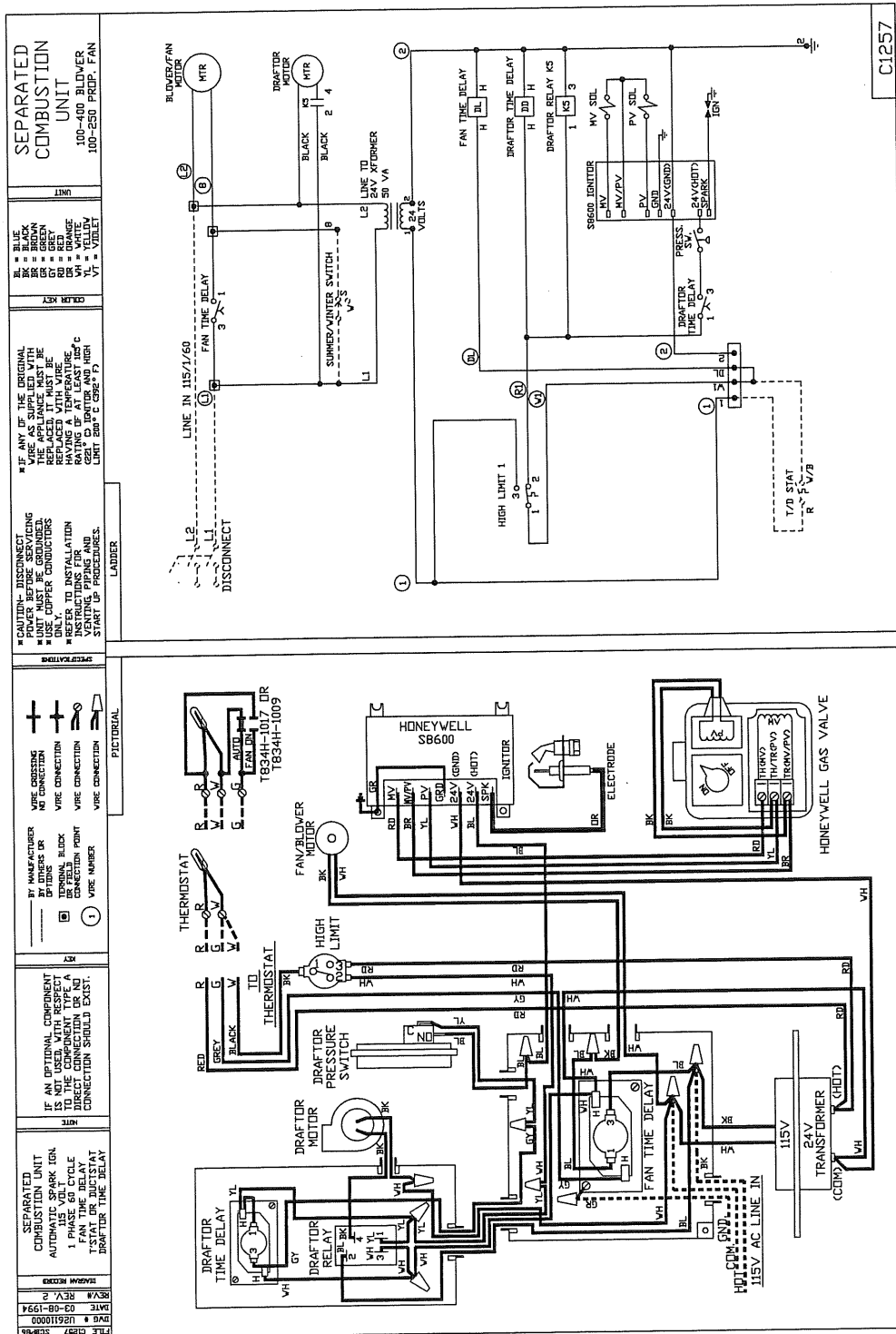

Wiring Diagrams

Figure 25. Separated combustion unit, 300-400 blower, dual prop.

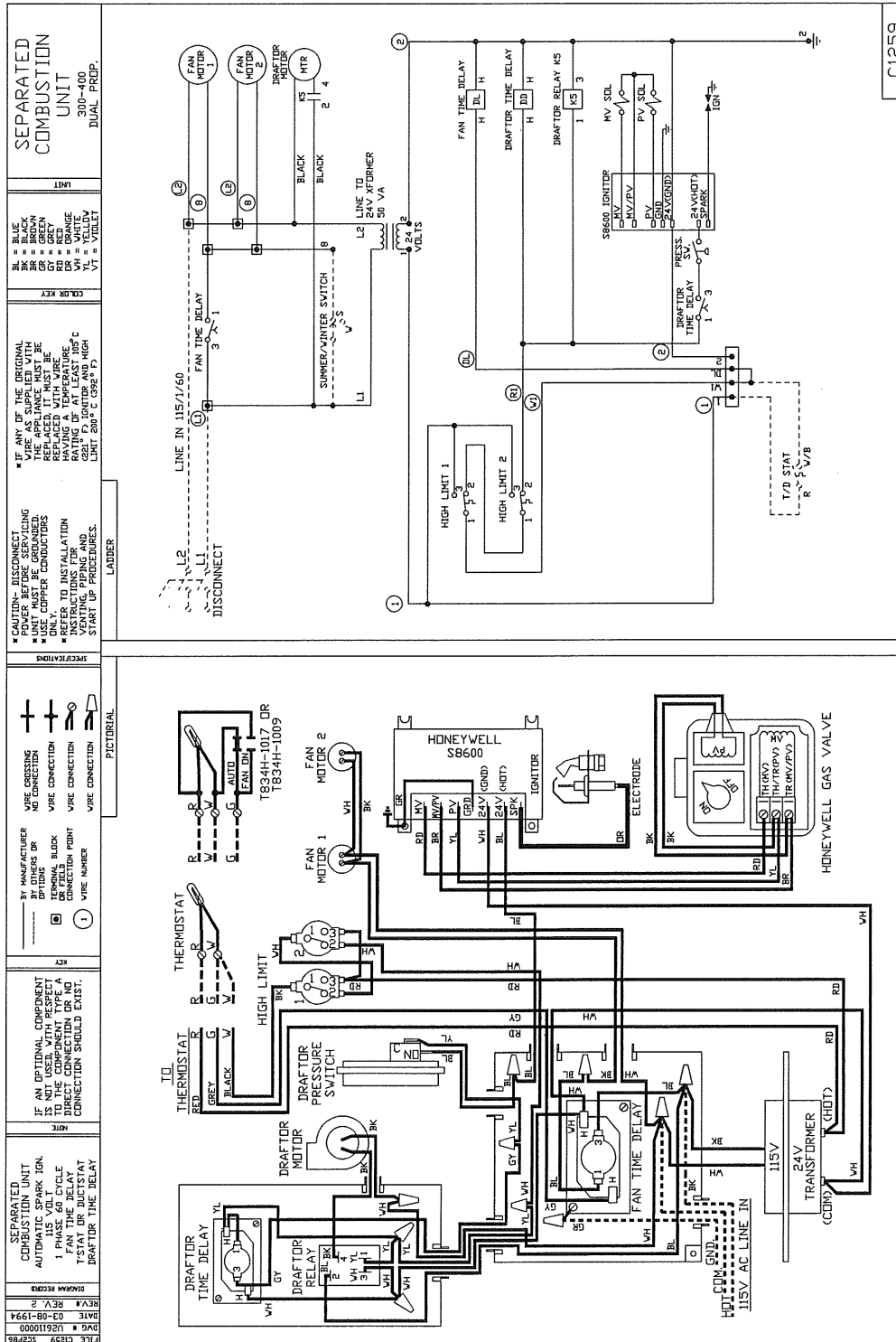
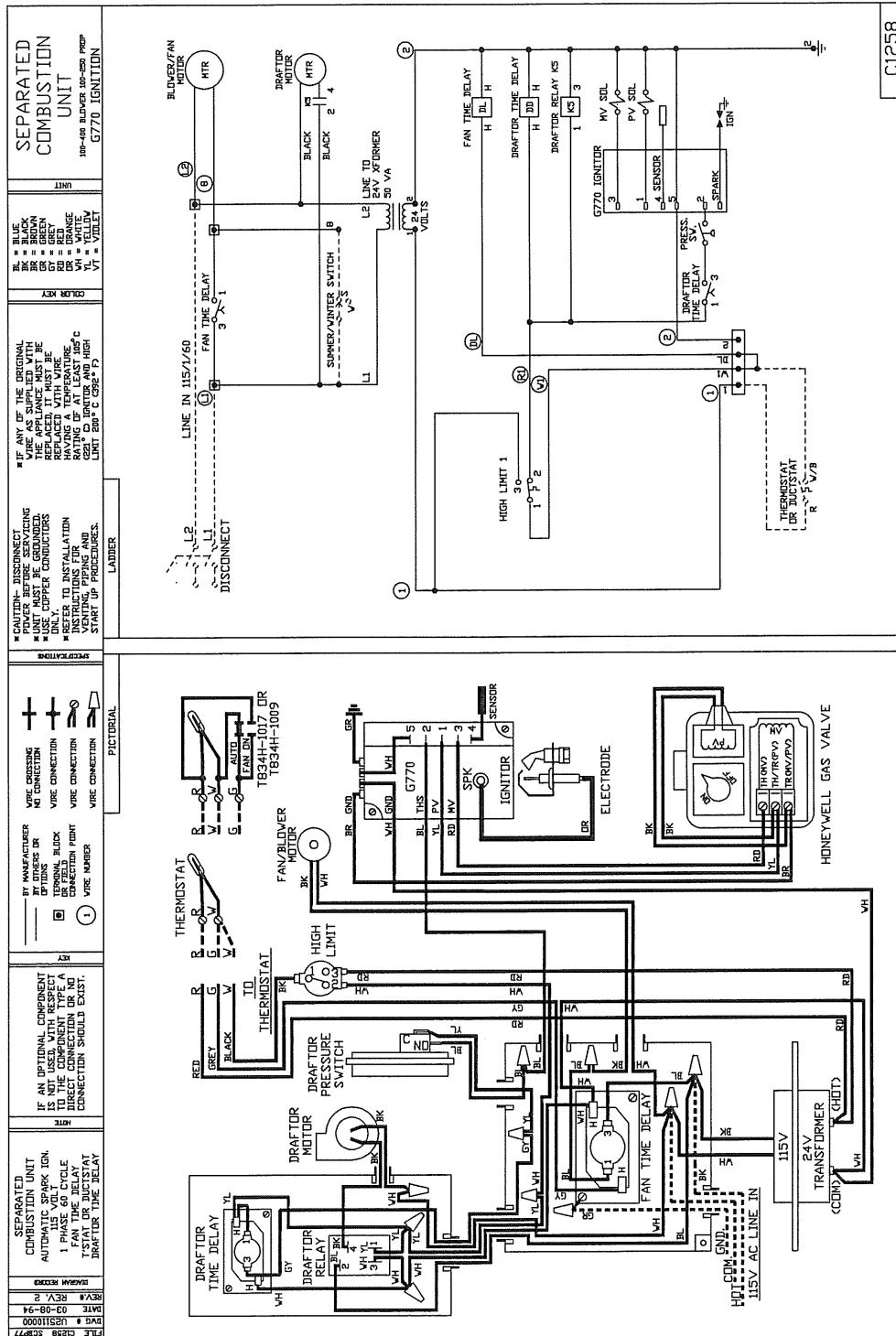
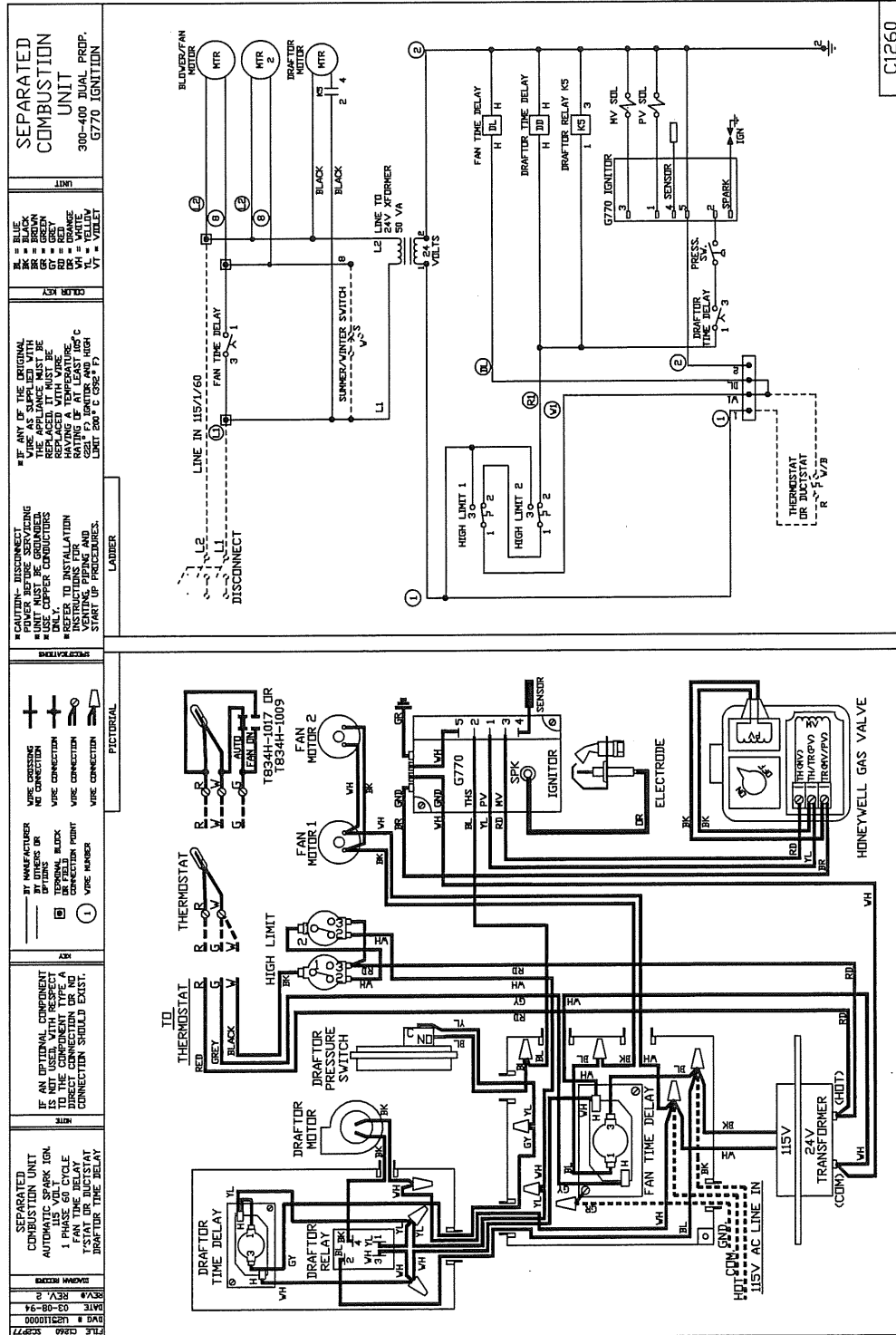

Figure 26. Separated combustion unit, 100-400 blower, 100-250 prop, G770 ignition



Wiring Diagrams

Figure 27. Separated combustion unit, 300-400 dual prop., G770 ignition





TRANE®

www.trane.com

For more information, contact your local Trane office or e-mail us at comfort@trane.com

Literature Order Number	GAND-SVX01A-EN
Date	March 2010
Supersedes	GAND-IOM-1 January 2006

Trane has a policy of continuous product and product data improvement and reserves the right to change design and specifications without notice.

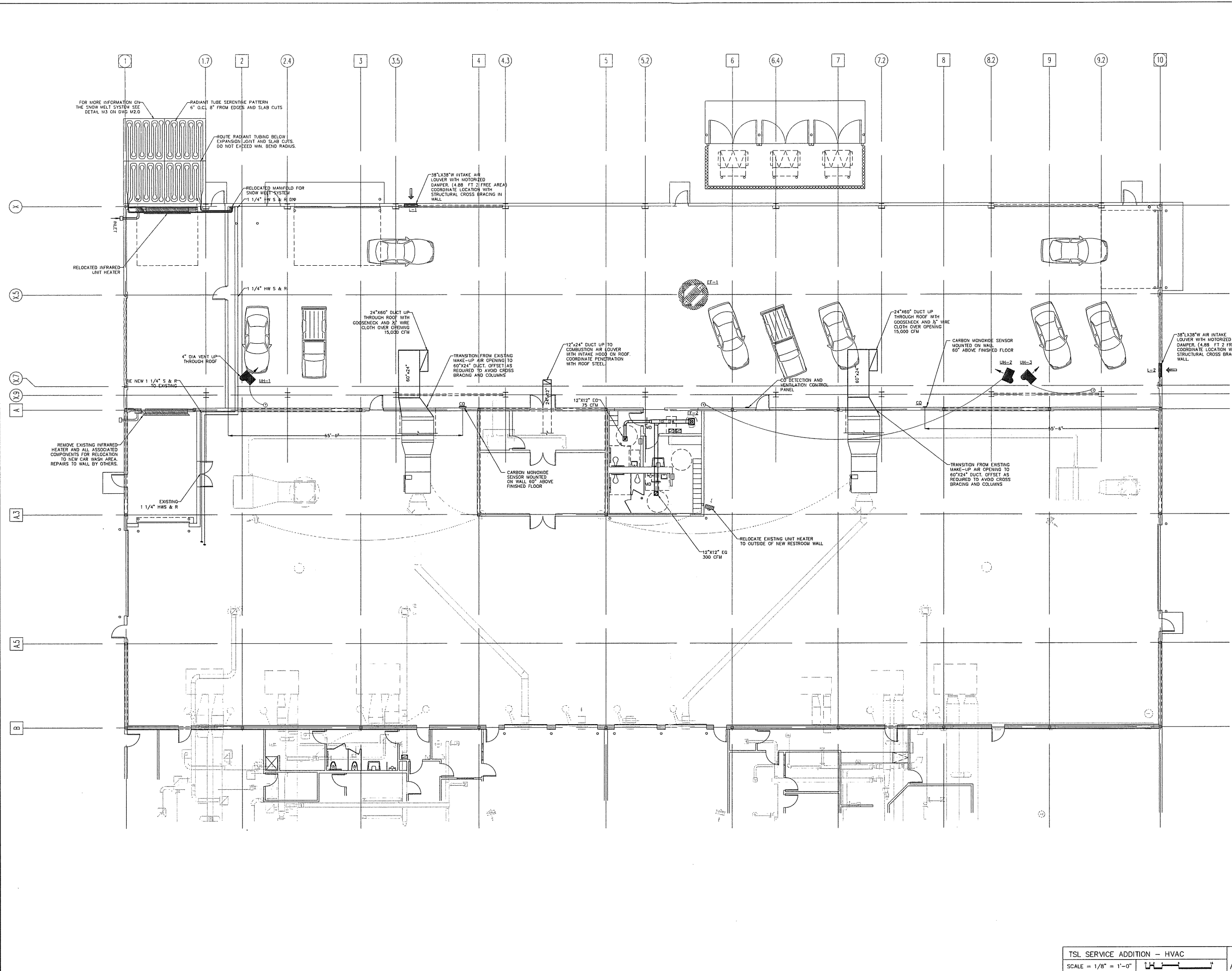

This document is issued by, and the liability for its accuracy rests with, Titan Mechanical, Inc. It is not to be used for any other project without the written consent of Titan Mechanical, Inc. and agrees to return the drawings to Titan Mechanical, Inc. upon completion of the project.

DATE	REVISIONS

Titan Mechanical, Inc.
 Design/Build Engineering - Mechanical Contracting
 P.O. Box 3927 / 232 Riverside Ind. Pkwy.
 Portland, Maine 04104
 Ph. (207) 878-5223 Fax. (207) 878-5235

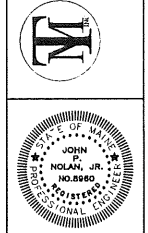

REMOVE EXISTING INFRARED HEATER AND ALL ASSOCIATED COMPONENTS FOR RELOCATION TO NEW CAR WASH AREA. REPAIRS TO WALL BY OTHERS.

CLIENT	MAINE MALL MOTORS
PROJECT	TSL SERVICE ADDITION
DRAWING TITLE	FIRST FLOOR PLAN - HVAC
DATE:	03/28/12
SCALE:	1/8" = 1'-0"
DRAWN BY:	SGH
CHECKED BY:	JPN
JOB NUMBER:	XXXX
CAD FILE:	XXXX
SHEET NUMBER	
M1.0	
SHEET 1 OF 5	

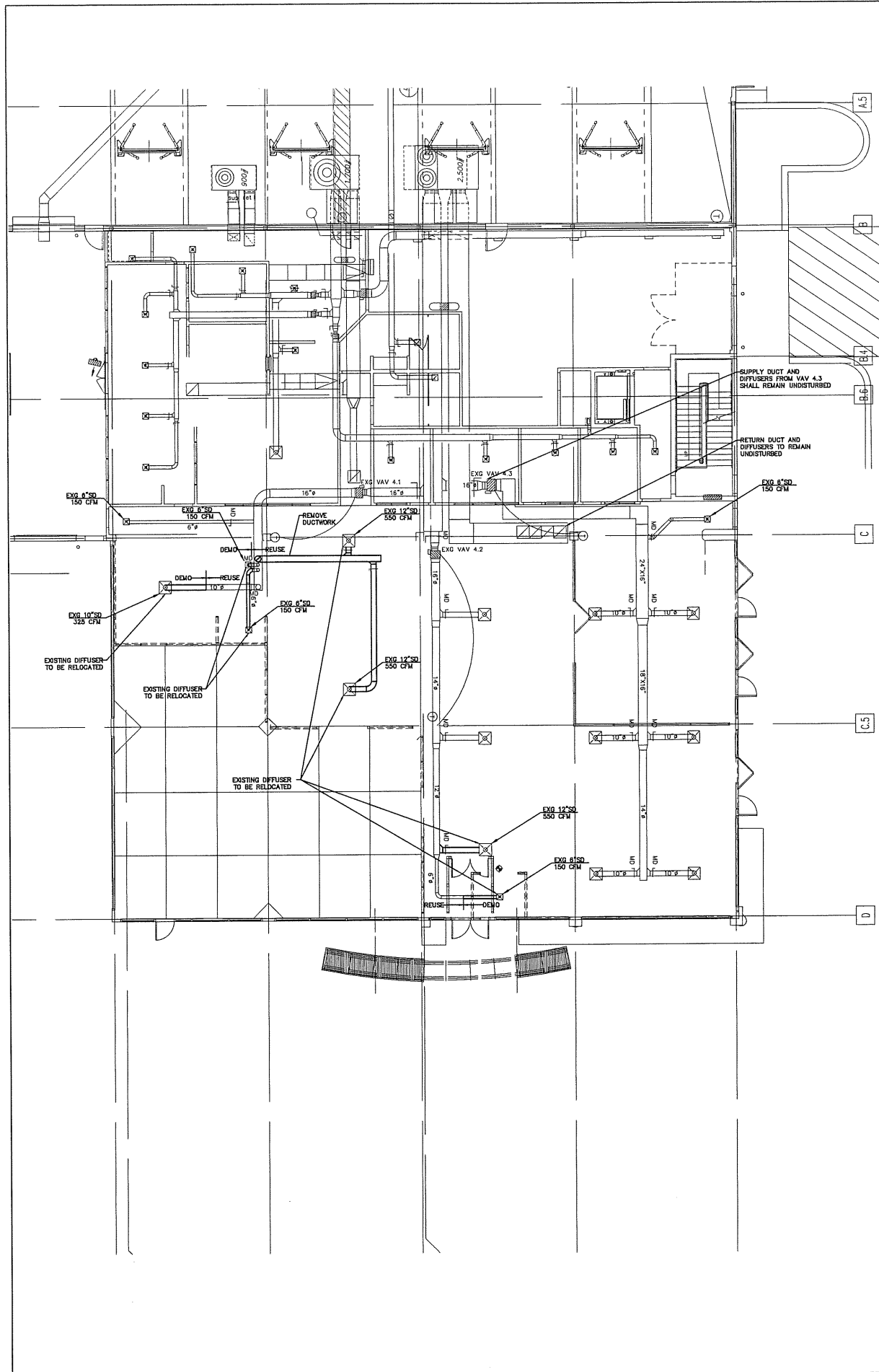

TSL SHOWROOM ADDITION - HVAC DEMO
 SCALE = 1/8" = 1'-0" A2

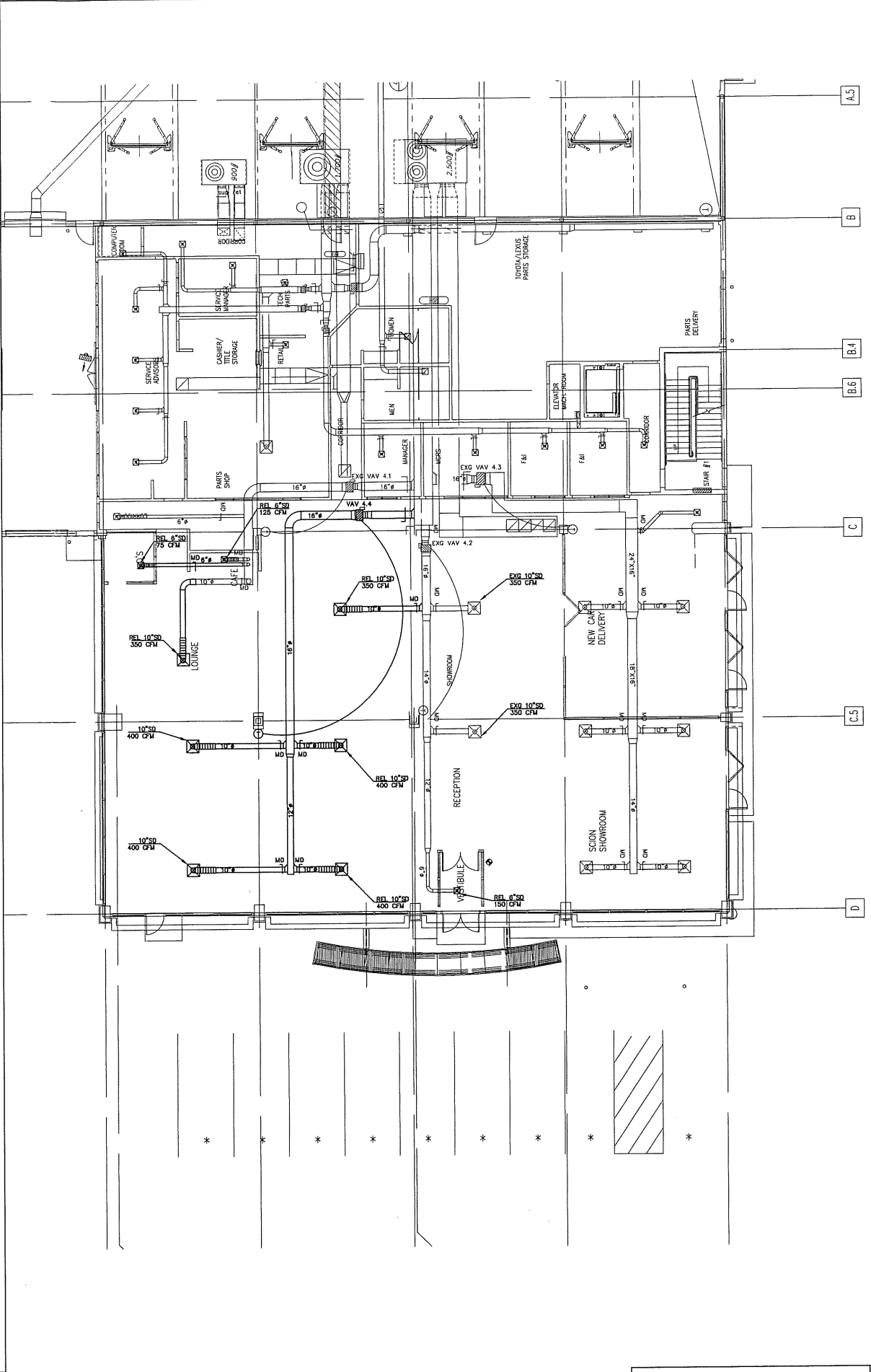

TSL SHOWROOM ADDITION - HVAC NEW
 SCALE = 1/8" = 1'-0" A1

<p>NO PART OF THIS DOCUMENT IS TO BE REPRODUCED OR TRANSMITTED IN ANY FORM OR BY ANY MEANS, ELECTRONIC OR MECHANICAL, INCLUDING PHOTOCOPYING, RECORDING, OR BY ANY INFORMATION STORAGE AND RETRIEVAL SYSTEM, WITHOUT THE WRITTEN PERMISSION OF THE ENGINEER.</p>	
DATE	
REVISIONS	
<p>Titan Mechanical, Inc. Design Build Engineering - Mechanical Contracting P.O. Box 3927 / 232 Riverside Ind. Pkwy. Portland, Maine 04104 Ph. (207) 878-5223 Fax. (207) 878-5235</p>	
<p>MAINE MALL MOTORS CLIENT TSL SHOWROOM ADDITION PROJECT FIRST FLOOR PLAN - HVAC DRAWING TITLE</p>	
<p>DATE: 03/28/12 SCALE: 1/8" = 1'-0" DRAWN BY: SGH CHECKED BY: JPN JOB NUMBER: XXXX CAD FILE: XXXX SHEET NUMBER</p>	
<p>M1.1 SHEET 1 OF 5</p>	

FAN SCHEDULE											
TAG	SERVES	CFM	SP W.G.	V/PH	HP	TS	RPM	WGT POUNDS	MOD. NO.	REMARKS	
EF-1	SERVICE GARAGE AREA	8,850	0.3	480/3	2		738	500	GREENHECK GP-260-2	ROOF	
EF-2	RESTROOMS	375	0.25	120/1	1/4		1300	50	GREENHECK GB-101-HP-5	ROOF	

LOUVER SCHEDULE											
TAG	SERVES	CFM	SIZE	MOD. NO.	REMARKS						
L-1	SERVICE GARAGE AREA	4,000	38"x38"		WITH MOTORIZED DAMPER						
L-2	SERVICE GARAGE AREA	4,000	38"x38"		WITH MOTORIZED DAMPER						

RADIANT HEATING TUBING SCHEDULE											
ZONE	MANFOLD	LOCATION	AREA FT ²	LOOPS	LENGTH FT	GPM	HEAD FT	TUBE TYPE	TUBE SPACING	CONTROL	REMARKS
1	RELOC.	CARWASH RAMP & ENTRANCE	400	4	250, 220 210, 180	8	18'	3/4" PEX	8" O.C.	IN-SLAB THERMOSTAT	HDR P. GLYCOL IN WATER

RELOCATED GAS FIRED INFRARED HEATER SCHEDULE											
TAG	SERVES	INPUT MBH	OUTPUT MBH	EFF. %	BURNER % FUEL	SIZE LXWXH	VENT SIZE IN	WGT POUNDS	MOD. NO.	REMARKS	
IRH-1	CARWASH	40	32	80	NAT. GAS		4"			EXISTING RELOCATED	

UNIT HEATER SCHEDULE											
TAG	AREA SERVED	TYPE	CFM	HP	AMPS	ELECTRIC	MODEL	REMARKS			
UH-1,2&3	SVC GARAGE	PROPELLER	200	180	2,640	1/3	4.5	120/80/1 TRANE MOD No. GAND020 WITH VENT FAN			

CO SENSORS											
TAG	AREA SERVED	TYPE	CO RANGE	COVERAGE	ELECTRIC	REMARKS					
CO	SVC GARAGE	WALL HUNG	0-250	5000 SQ FT	12-24V	MACURCO JCM-4 WITH CONTROLLER DVP-120					

GRILLES, REGISTERS, & DIFFUSER SCHEDULE											
TAG	NECK INCHES	FACE SIZE INCHES	MAX CFM	SP W.G.	THROW FEET	REMARKS					
SD-1	8"	12x12	0-150	0.05	-	ANEMOSTAT EPL, LAY-IN STYLE					
SD-2	10"	24x24	251-400	0.05	-	ANEMOSTAT EPL, LAY-IN STYLE					
ED-1	8"	12X12	0-300	0.05	-	ANEMOSTAT X3HD					

VAV BOX SCHEDULE											
TAG	SERVES	MAX CFM	MIN CFM	MIN CFM	MODEL	REMARKS					
VAV-4.1	KID'S ROOM, CAFE AND LOUNGE	700	350	350	TRANE VCCF-14	HVAC-6, EXISTING, MAX COOLING - 1725					
VAV-4.2	TSL SHOWROOM EXISTING	1250	625	625	TRANE VCCF-14	HVAC-6, EXISTING, MAX COOLING - 1800					
VAV-4.3	TSL SHOWROOM AND NEW CAR DELIV	3450	1725	1725	TRANE VCCF-16	HVAC-6, EXISTING, NO CHANGE					
VAV-4.4	TSL SHOWROOM ADDITION	1600	800	800	TRANE VCCF-14	HVAC-6, NEW					

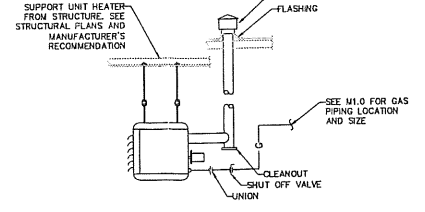

1 M1.0 NO SCALE
GAS FIRED UNIT HEATER DETAIL

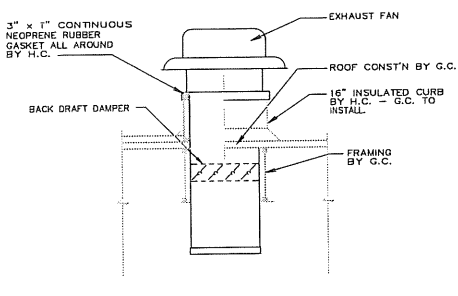

2 M1.0 NO SCALE
ROOF EXHAUST FAN

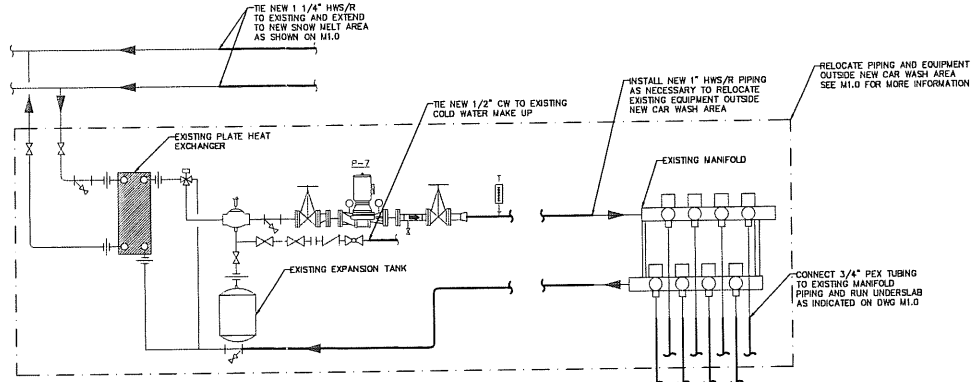

3 M1.0 NO SCALE
RELOCATED SNOW MELT SYSTEM DETAIL

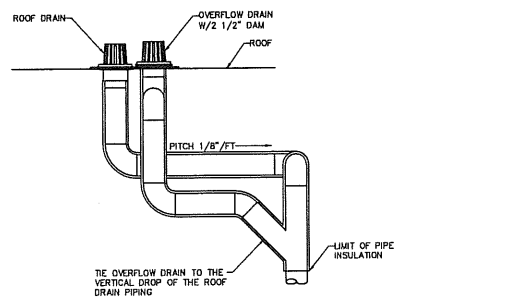

4 M1.0 NO SCALE
COMBINATION ROOF AND OVERFLOW DRAIN DETAIL

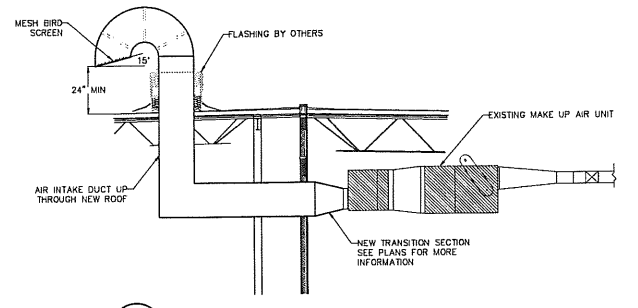

4 M1.0 NO SCALE
AIR INTAKE GOOSENECK DETAIL

PLUMBING FIXTURE SCHEDULE											
TAG	FIXTURE	CW	HW	WASTE	VENT	MODEL	REMARKS				
P-1	WATER CLOSET, FLOOR MOUNTED	1"		4"	2"	AMERICAN STANDARD "MADORA" 1.28 GPF W/ SLOAN 111-1.28 HE FLUSH VALVE, 15" TO RIM					
P-1A	ADA WATER CLOSET, FLOOR MOUNTED	1"		4"	2"	AMERICAN STANDARD "MADORA" 1.28 GPF W/ SLOAN 111-1.28 HE FLUSH VALVE, 17" TO RIM					
P-2	ADA URINAL, WALL HUNG	1"		2"	1 1/2"	AMERICAN STANDARD "WASHBROOK" 0.5 GPF W/ SLOAN 188-0.5 HEU FLUSH VALVE, 17" TO RIM					
P-3	ADA LAVATORY, WALL HUNG	1/2"	1/2"	1-1/2"	1-1/2"	AMERICAN STANDARD "LUCERNE" W/ SYMONS S-2200 FAUCET, 0.5 GPM, 34" TO RIM					
P-4	WASH SINK	1/2"	1/2"	2"	1 1/2"	ZURN MS2623 DOUBLE COMPARTMENT SINK WITH (2) CHICAGO FAUCET 885-LBVB2-2CP					
P-5	ELECTRIC WATER COOLER	1/2"		2"	1 1/2"	HALSEY TAYOR BI-LEVEL ADA WATER COOLER MODEL # HAC80BL-C-ADA 120V, 4.0 FLA, 370W					
P-6	FROST PROOF WALL HYDRANT	1/2"				EXPOSED, NON FREEZE, ANTI SIPHON, AUTO DRAIN SS FACE WITH OPERATING KEY					
P-7	EYEWASH	1/2"	1/2"	2"	1 1/2"	GUARDIAN G1814P WALL MOUNTED EYEWASH WITH TEMPERING VALVE, SET TO 65 DEGREES					
FD-1	FLOOR DRAIN - RESTROOMS	1/4"		2"	1 1/2"	WATTS 6" DIA FD-100-A W/ TRAP PRIMER CONNECTION					
FD-2	FLOOR DRAIN - ALIGNMENT BAY	1/4"		4"	2"	WATTS 8" SQ FD-100-L HINGED GRATE SEDIMENT BUCKET AND TRAP PRIMER CONNECTION					
TD-1	TRENCH DRAIN SERVICE AREA	1/4"		4"	2"	WATTS 90 FEET DEAD LEVEL DX-RGS-FG WITH CS624 CATCH BASIN W/TRASH BASKET					
TD-2	TRENCH DRAIN CAR WASH	1/4"		4"	2"	WATTS 90 FEET DEAD LEVEL DX-RGS-FG WITH CS-824 CATCH BASIN W/TRASH BASKET					
RD-1	ROOF/OVERFLOW DRAIN					WATTS RD-280 COMBINATION RO/OVERFLOW W/DECK FLANGE, SIZE NOTED ON PLAN					

- GENERAL NOTES
1. PROVIDE DUCTWORK IN ACCORDANCE WITH NFPA 90A AND LOCAL CODES AND STANDARDS.
 2. PROVIDE DUCTWORK IN ACCORDANCE WITH SMACNA STANDARDS (SECOND EDITION - 1985) "STD" PRESSURE CLASSIFICATION, SEAL CLASS "C", USING GALVANIZED SHEET METAL.
 3. INSTALL FLEX DUCT IN MAXIMUM 5 FOOT LENGTHS, FULLY EXTENDED, PROPERLY SUPPORTED, WITHOUT CRUMPS.
 4. DUCT ELBOWS SHALL BE STANDARD RADIUS TYPE OR SQUARE WITH SINGLE TURNING VANES.

SYMBOLS AND ABBREVIATIONS											
AFF	ABOVE FINISH FLOOR	HWS	HOT WATER SUPPLY PIPING								
AFO	ABOVE FINISH GRADE	HWR	HOT WATER RETURN PIPING								
AP	ACCESS PANEL	FCV	FLOW CONTROL VALVE								
CFM	CUBIC FEET PER MINUTE	ZC	ZONE CIRCULATOR								
D	DRAIN	MV	MANUAL VENT								
DW	DOWN IN WALL	FV	FLOAT VENT								
DSD	DUCT SMOKE DETECTOR	RV	RELIEF VENT								
EF	EXHAUST FAN	PA	PIPE ANCHOR								
EW	ENTERING WATER TEMPERATURE	D	DRAIN PIPING								
FP	FINISHED PIPE	U	UNION								
G	GAS PIPING	F	FLANGE								
GC	GENERAL CONTRACTOR	GV	GATE VALVE								
GPM	GALLONS PER MINUTE	HC	HEATING CONTRACTOR								
GV	GATE VALVE	HWR	HOT WATER RETURN								
H	HEATING CONTRACTOR	HWS	HOT WATER SUPPLY								
HCR	HOT WATER RETURN	HZ	HERTZ								
HWS	HOT WATER SUPPLY	MV	MANUAL VENT								
HZ	HERTZ	MBH	1000 BTU PER HOUR								
MV	MANUAL VENT	MC	NOT IN CONTRACT								
MBH	1000 BTU PER HOUR	NTS	NOT TO SCALE								
MC	NOT IN CONTRACT	P	PUMP								
NTS	NOT TO SCALE	PQ	PRESSURE GAUGE								
P	PUMP	PH	PHASE								
PQ	PRESSURE GAUGE	PRV	PRESSURE REDUCING VALVE								
PH	PHASE	T	THERMOSTAT								
PRV	PRESSURE REDUCING VALVE	VT	VENT								
T	THERMOSTAT	V	VOLTS								
VT	VENT	WPD	WATER PRESSURE DROP								
V	VOLTS	WTD	WATER TEMPERATURE DROP								
WPD	WATER PRESSURE DROP	WTR	WATER TEMPERATURE RISE								
WTD	WATER TEMPERATURE DROP										
WTR	WATER TEMPERATURE RISE										

This drawing is issued by and the information contained in it is proprietary to Titan Mechanical, Inc. By request to Titan Mechanical, Inc. in writing, information, advice or to any third party, not release this information without the written consent of Titan Mechanical, Inc. and agree to return this information to Titan Mechanical, Inc. upon request.

REVISIONS

DATE	DESCRIPTION

Titan Mechanical, Inc.
Design Build Engineering - Mechanical Contracting
P.O. Box 3927 / 232 Riverside Ind. Pkwy.
Portland, Maine 04104
Ph: (207) 878-5223 Fax: (207) 878-5235

JOHN P. HOLLAN, JR.
LICENSED PROFESSIONAL ENGINEER
MAINE

DATE: 03/28/12
SCALE: 1/8" = 1'-0"
DRAWN BY: SGH
CHECKED BY: JPN
JOB NUMBER: XXXX
CAD FILE: XXXX
SHEET NUMBER

MAIN MALL MOTORS
CLIENT
TSL SERVICE ADDITION
PROJECT
HVAC AND PLUMBING - SCHEDULES & DETAILS
DRAWING TITLE

M2.0
SHEET 3 OF 5

This document is owned by, and the information contained herein is the property of Titan Mechanical, Inc. It is to be used for the project and location specified herein only. No part of this document may be reproduced without the written consent of Titan Mechanical, Inc. and copies to other projects are prohibited.

DATE	REVISIONS

Titan Mechanical, Inc.
 Design Build Engineering - Mechanical Contracting
 P.O. Box 3927 / 232 Riverside Ind. Pkwy.
 Portland, Maine 04104
 Ph. (207) 878-5223 Fax. (207) 878-5235

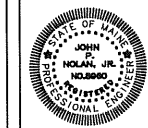

CLIENT: MAINE MALL MOTORS
 PROJECT: TSL SERVICE ADDITION
 DRAWING TITLE: FIRST FLOOR PLUMBING PLAN - DRAINAGE

DATE: 03/28/12
 SCALE: 1/8" = 1'-0"
 DRAWN BY: SGH
 CHECKED BY: JPN
 JOB NUMBER: XXXX
 CAD FILE: XXXX
 SHEET NUMBER

P1.0
 SHEET 4 OF 5

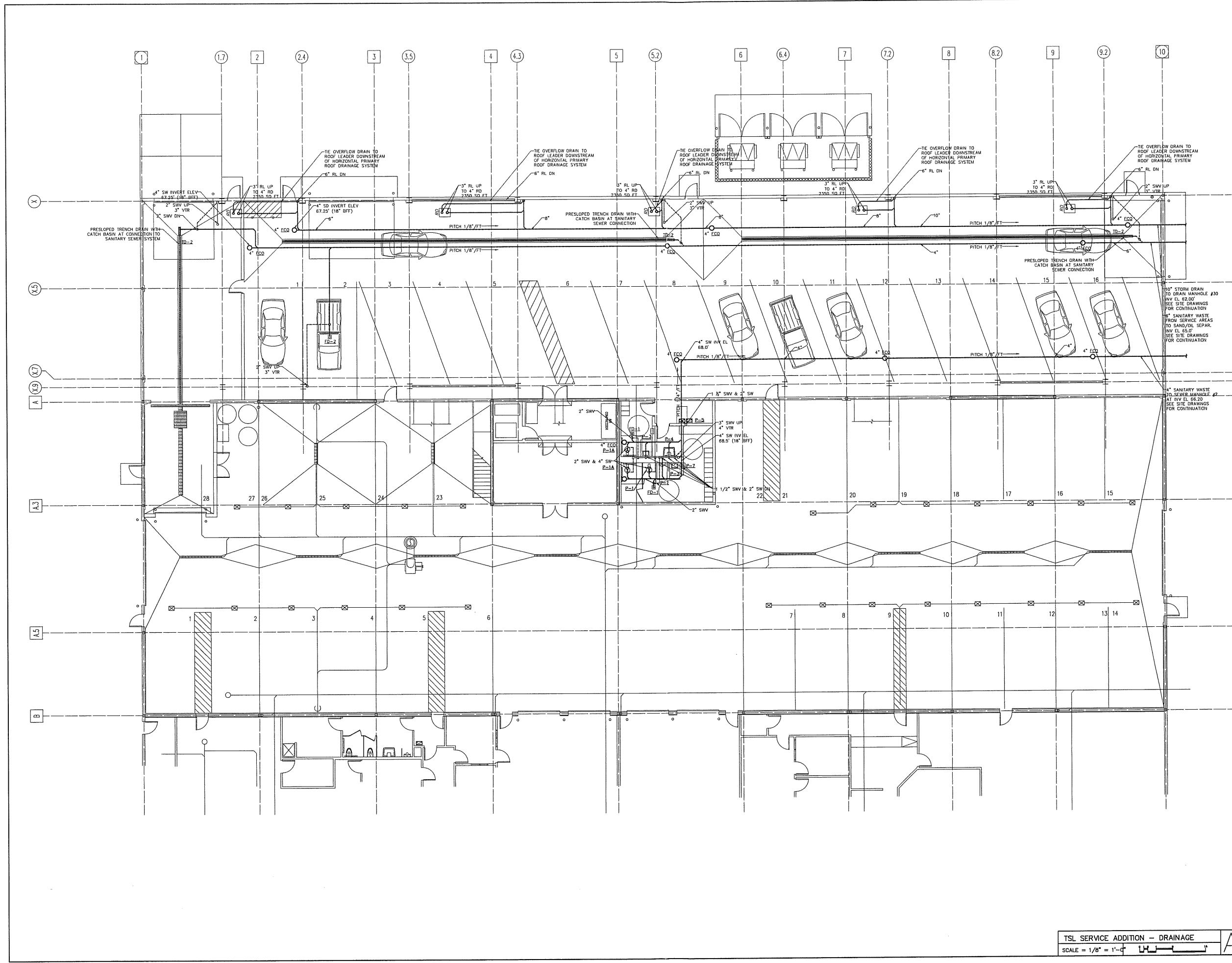

TSL SERVICE ADDITION - DRAINAGE
 SCALE = 1/8" = 1'-0" A1

The Engineer is not responsible for the information contained in this preliminary drawing. The Engineer is not responsible for the information contained in this preliminary drawing. The Engineer is not responsible for the information contained in this preliminary drawing.

REVISIONS	DATE

Titan Mechanical, Inc.
 Design Build Engineering - Mechanical Contracting
 P.O. Box 3927 / 232 Riverside Ind. Pkwy.
 Portland, Maine 04104
 Ph. (207) 878-5223 Fax. (207) 878-5235

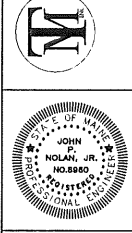

MAINE MALL MOTORS
 CLIENT
 TSL SERVICE ADDITION
 PROJECT
 FIRST FLOOR PLUMBING PLAN - SUPPLY
 DRAWING TITLE

DATE: 03/28/12
 SCALE: 1/8" = 1'-0"
 DRAWN BY: SGH
 CHECKED BY: JPN
 JOB NUMBER:
 CAD FILE:
 SHEET NUMBER

P2.0
 SHEET 5 OF 5

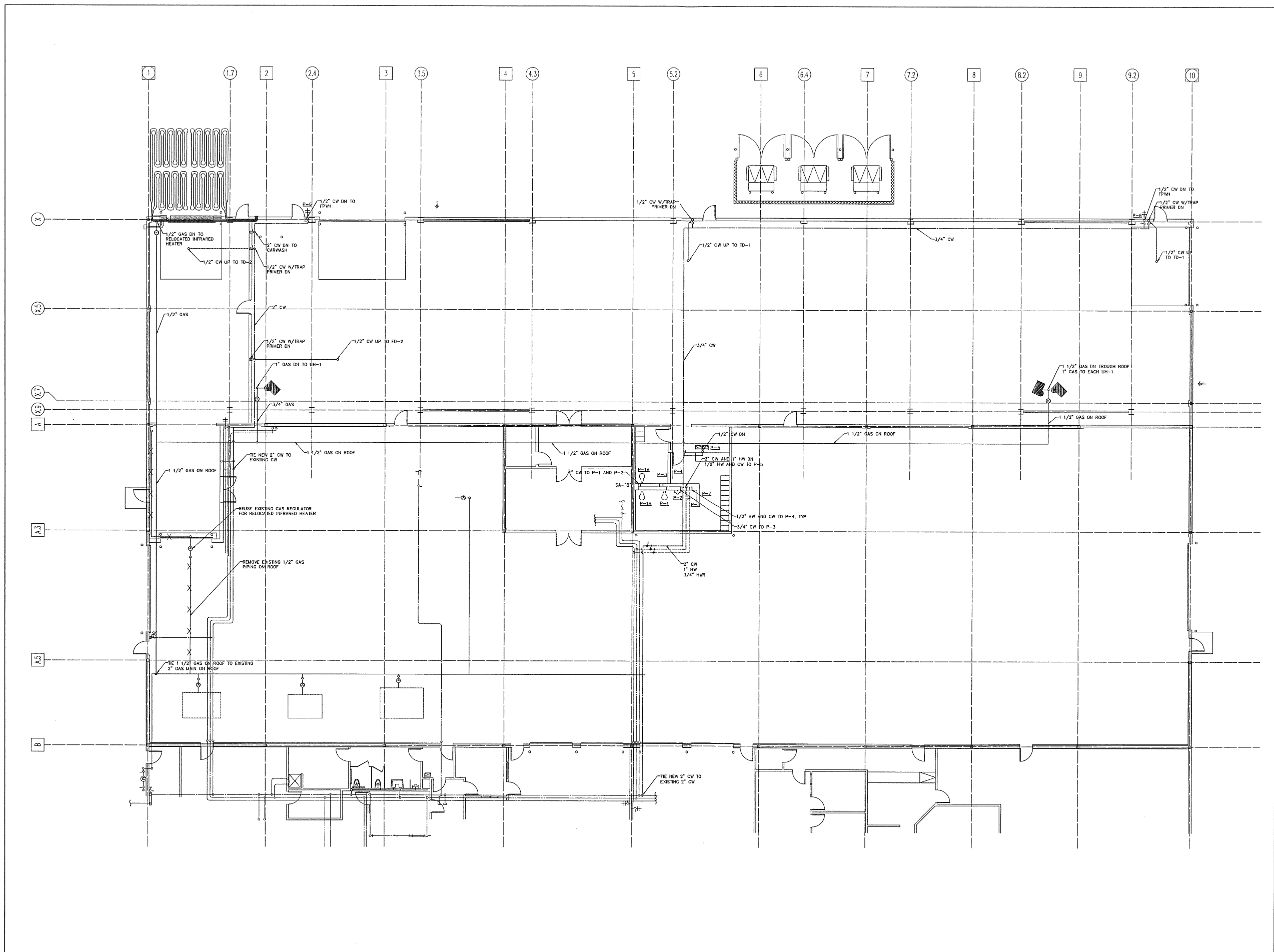

TSL SERVICE ADDITION - SUPPLY
 SCALE = 1/8" = 1'-0" A1