

DISPLAY THIS CARD ON PRINCIPAL FRONTAGE OF WORK CITY OF PORTLAND

Please Read Application And Notes, If Any, Attached

BUILDING DEPARTMENT

PERMIT

Permit Number: 030034

This is to certify that GCA/Motel 6/Glen Duvall
has permission to Renovations to 58 Bathroom Motel
AT 1 Riverside St 266 A001001

provided that the person or persons, firm or corporation accepting this permit shall comply with all of the provisions of the Statutes of Maine and of the ordinances of the City of Portland regulating the construction, maintenance and use of buildings and structures, and of the application on file in this department.

Apply to Public Works for street line and grade if nature of work requires such information.

Notification of inspection must be given and work on permit must be completed before this building or part thereof is opened or closed-in. **48 HOUR NOTICE IS REQUIRED.**

A certificate of occupancy must be procured by owner before this building or part thereof is occupied.

OTHER REQUIRED APPROVALS

Fire Dept. CRMS
Health Dept. _____
Appeal Board _____
Other _____
Department Name

[Signature]
August 11/23/03
Director - Building & Inspection Services

PENALTY FOR REMOVING THIS CARD

City of Portland, Maine - Building or Use Permit

389 Congress Street, 04101 Tel: (207) 874-8703, Fax: (207) 874-8716

Permit No: 03-0034	Date Applied For: 01/15/2003	CBL: 266 A001001
------------------------------	--	----------------------------

Location of Construction: 1 Riverside St	Owner Name: GCA/Motel 6	Owner Address: 10516 C F Hawn Freeway	Phone: 770-857-1842
Business Name:	Contractor Name: Glen Duvall	Contractor Address: 10516 CF Hawn Freeway Dallas	Phone (214) 801-1086
Lessee/Buyer's Name	Phone:	Permit Type: Alterations - Commercial	

Proposed Use: Motel	Proposed Project Description: Renovations to 58 Bathrooms in Motel
-------------------------------	--

Dept: Zoning **Status:** Approved **Reviewer:** Marge Schmuckal **Approval Date:** 01/21/2003
Note: **Ok to Issue:**

Dept: Building **Status:** Approved with Conditions **Reviewer:** Mike Nugent **Approval Date:** 01/23/2003
Note: **Ok to Issue:**

1) Bathroom Doors must be 32" in width, Confirmed with BOCA this date Mr. Duvall from Motel 6 agreed to conform.

Dept: Fire **Status:** Approved with Conditions **Reviewer:** Lt. McDougall **Approval Date:** 01/21/2003
Note: **Ok to Issue:**

1) the fire alarm system shall be maintained to NFPA 72 standards

03-0034

All Purpose Building Permit Application

If you or the property owner owes real estate or personal property taxes or user charges on any property within the City, payment arrangements must be made before permits of any kind are accepted.

Location/Address of Construction: <u>1 RIVERSIDE DR PORTLAND ME 04103</u>		
Total Square Footage of Proposed Structure	Square Footage of Lot	
Tax Assessor's Chart, Block & Lot Chart# <u>2ccc</u> Block# <u>A</u> Lot# <u>001</u>	Owner: <u>James J. White - Motel 6</u>	Telephone: <u>770-857-1842</u>
Lessee/Buyer's Name (if Applicable)	Applicant name, address & telephone: <u>G.C.A 10516 C. F. HAWN</u> <u>DALLAS TX 75217</u>	Cost Of Work: <u>\$12,100</u> Fee: <u>\$ 107.00</u>
Current use: <u>MOTEL 6</u>		
If the location is currently vacant, what was prior use: _____		
Approximately how long has it been vacant: _____		
Proposed use: <u>Motel 6</u>		
Project description: <u>Renovations to 58 Bathrooms in Motel</u>		
Contractor's name, address & telephone: <u>G.C.A 10516 C. F. HAWN FRWY DALLAS TX</u> <u>75217</u>		
Who should we contact when the permit is ready: <u>GLEN DUVAL</u>		
Mailing address: <u>214-801-1086 (cell) *</u>		
We will contact you by phone when the permit is ready. You must come in and pick up the permit and review the requirements before starting any work, with a Plan Reviewer. A stop work order will be issued and a \$100.00 fee if any work starts before the permit is picked up. PHONE:		

IF THE REQUIRED INFORMATION IS NOT INCLUDED IN THE SUBMISSIONS THE PERMIT WILL BE AUTOMATICALLY DENIED AT THE DISCRETION OF THE BUILDING/PLANNING DEPARTMENT, WE MAY REQUIRE ADDITIONAL INFORMATION IN ORDER TO APPROVE THIS PERMIT.

I hereby certify that I am the Owner of record of the named property, or that the owner of record authorizes the proposed work and that I have been authorized by the owner to make this application as his/her authorized agent. I agree to conform to all applicable laws of this jurisdiction. In addition, if a permit for work described in this application is issued, I certify that the Code Official's authorized representative shall have the authority to enter all areas covered by this permit at any reasonable hour to enforce the provisions of the codes applicable to this permit.

Signature of applicant: <u>[Signature]</u>	Date: <u>1-15-03</u>
--	----------------------

This is NOT a permit, you may not commence ANY work until the Department of Building Inspection City of Portland, ME. If you are in a Historic District you may be subject to additional permitting and fees with the Planning Department on the 4th floor of City Hall.

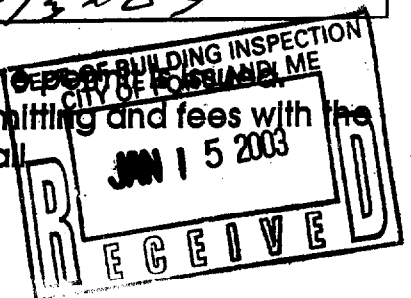

NEW BATHROOM # 1273 PORTLAND, ME.

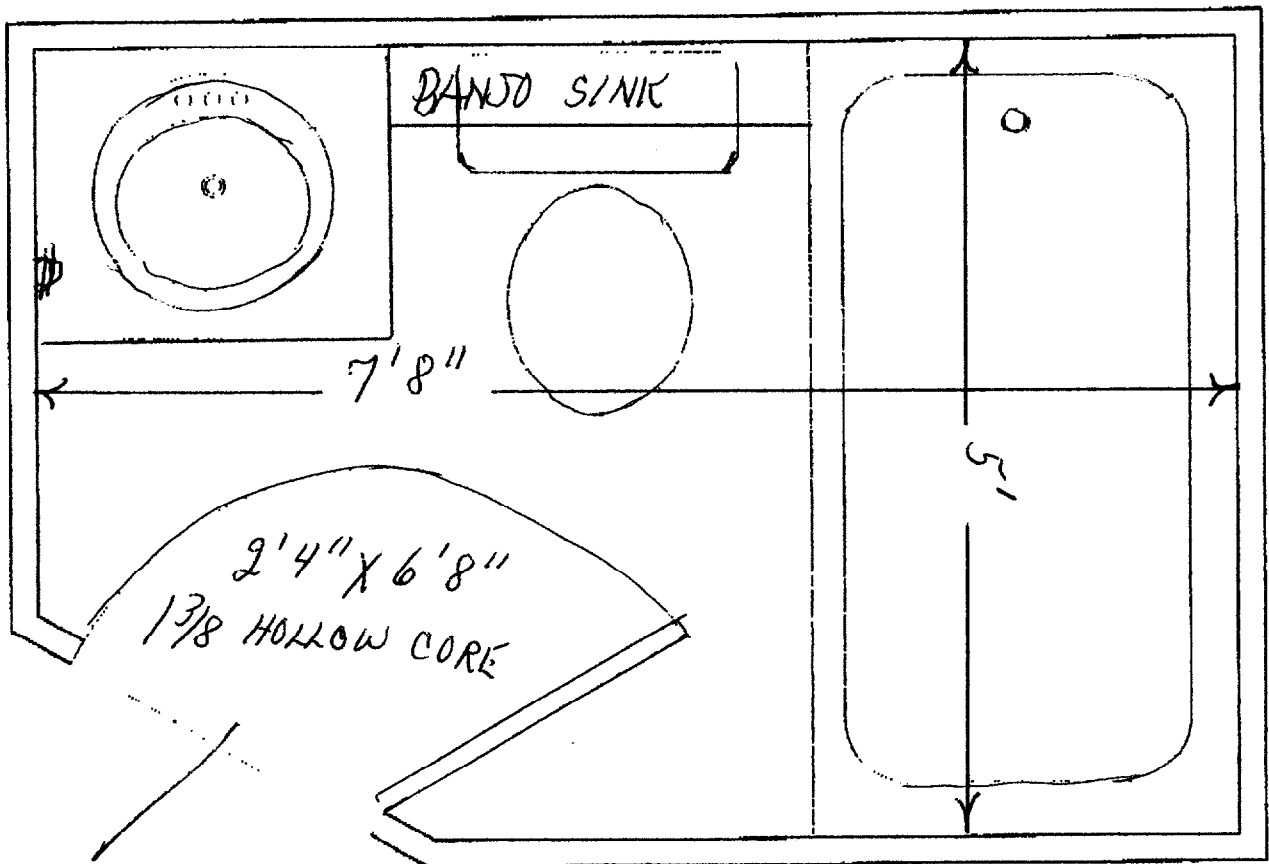

MUST BE 32" WIDE
[Signature]

58 R.H ROOMS

NEW BATHROOM # 1273 PORTLAND, ME.

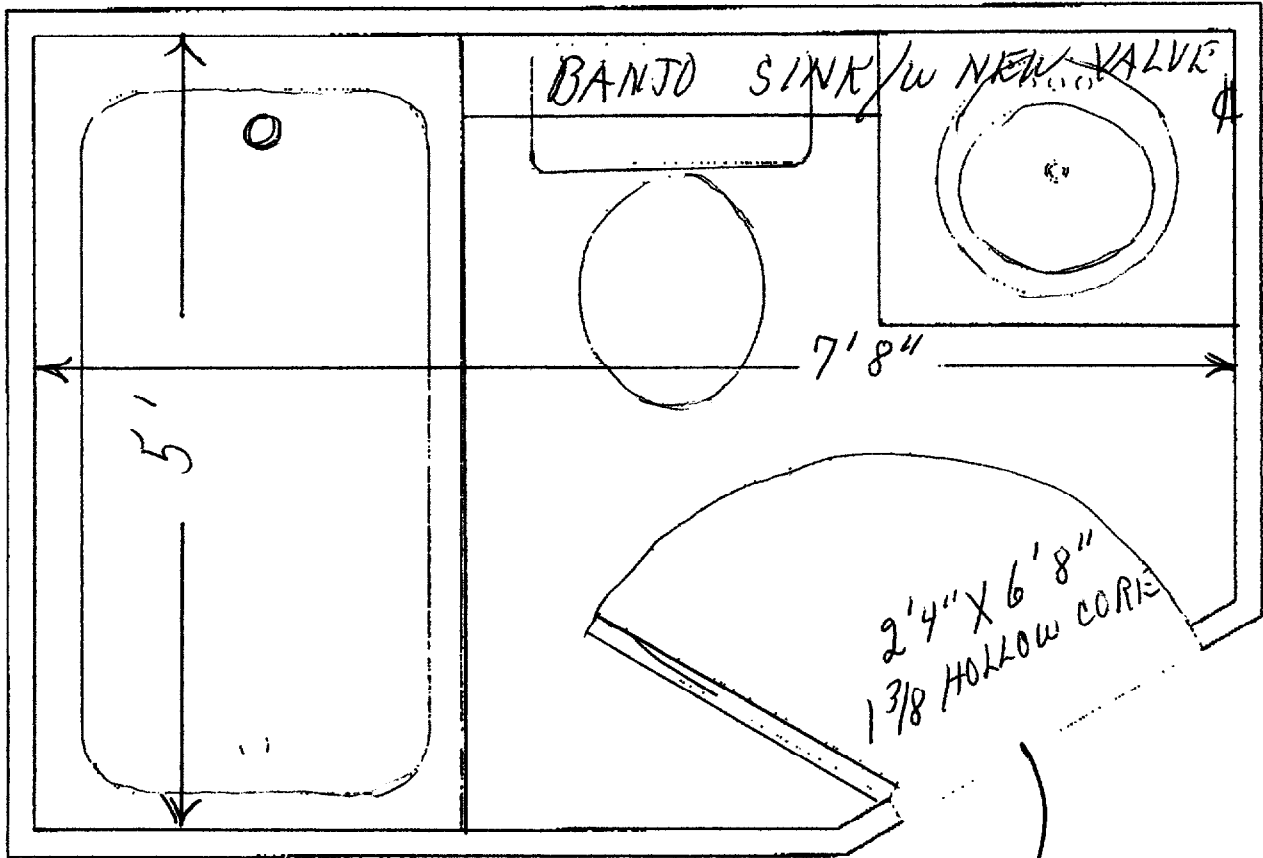

324
WIDE
OH

63 L.H ROOMS

1273 Portland, Me. - Bath wall

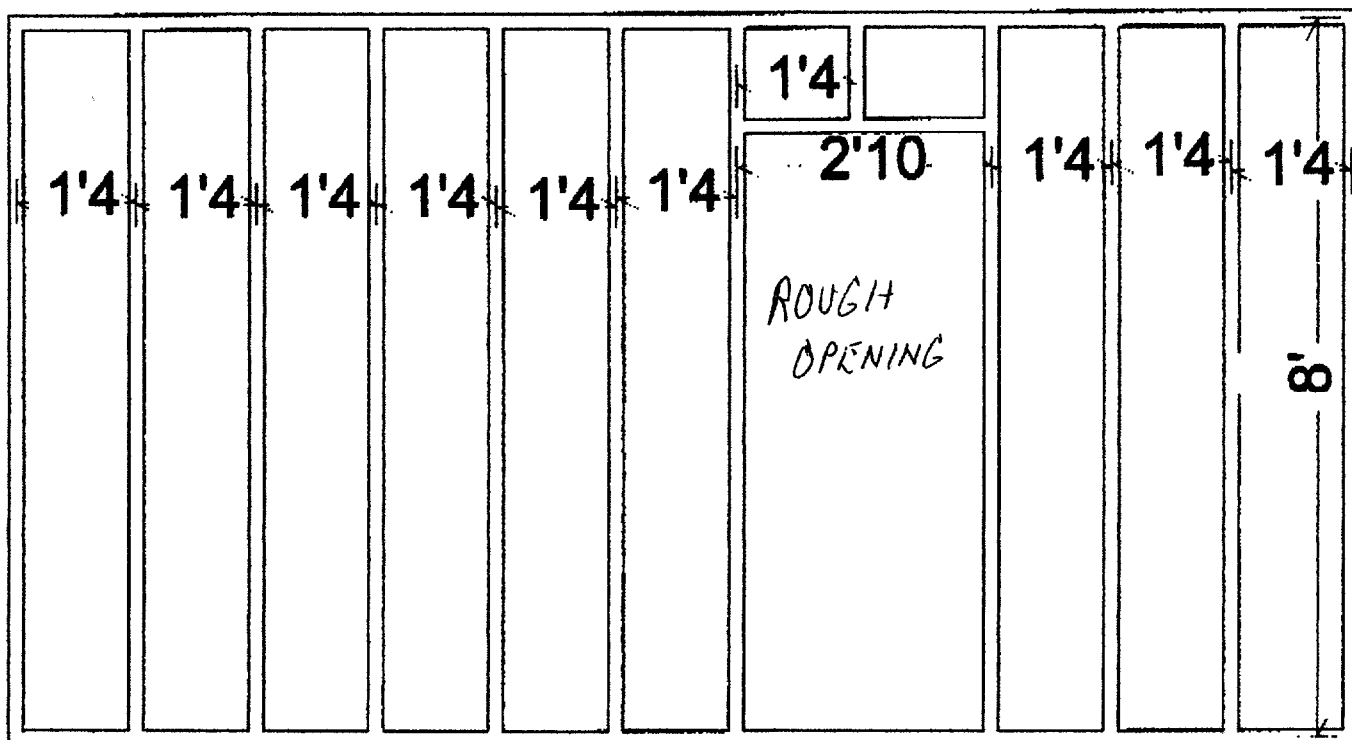

1273 Portland, Me.

This will be a 60" banjo sink

All new owner furnished ff&e

