

THRUST BLOCK PLACEMENT AT TEE(S)

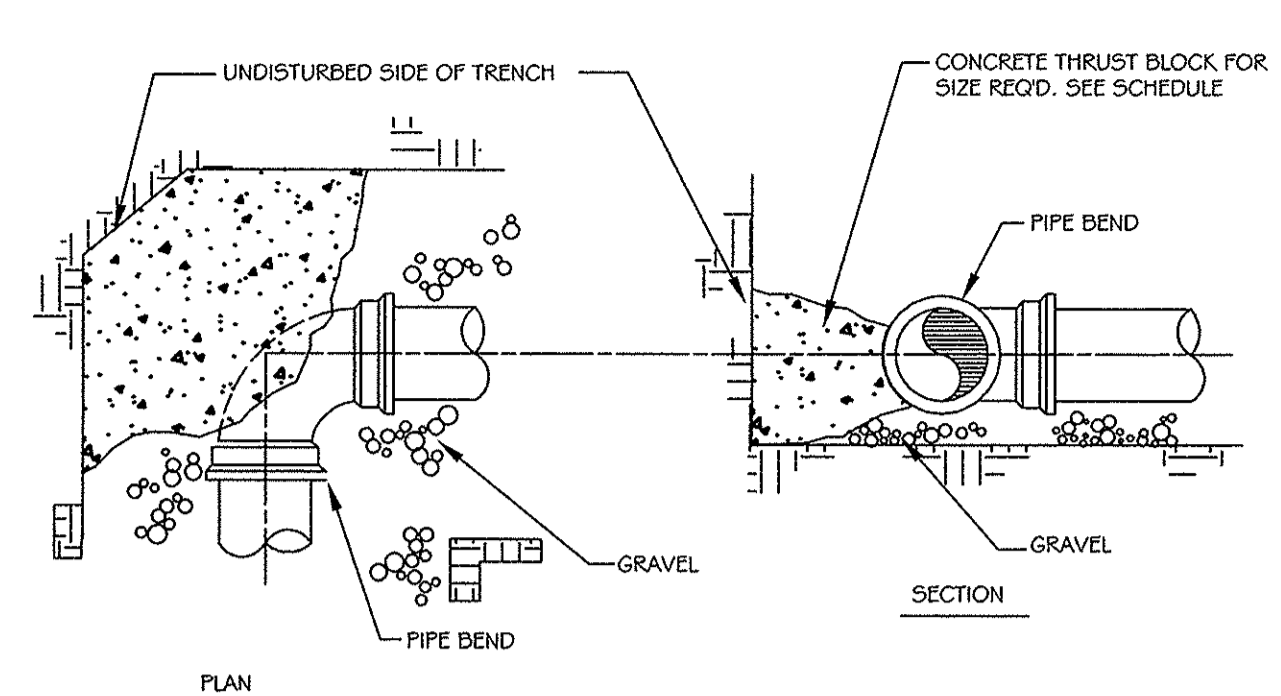

THRUST BLOCK PLACEMENT AT BEND(S)

SIZE REQUIREMENTS FOR CONCRETE THRUST BLOCKS					
BEARING ON UNDISTURBED SOIL (SQUARE FT.)					
FITTINGS	90° BENDS	45° BENDS	TEES & PLUGS	HYDRANTS	
4"	2.0	1.0	1.0	N/A	
6"	3.0	2.0	2.0	6.0	
8"	5.0	3.0	4.0	N/A	

THRUST BLOCK SCHEDULE

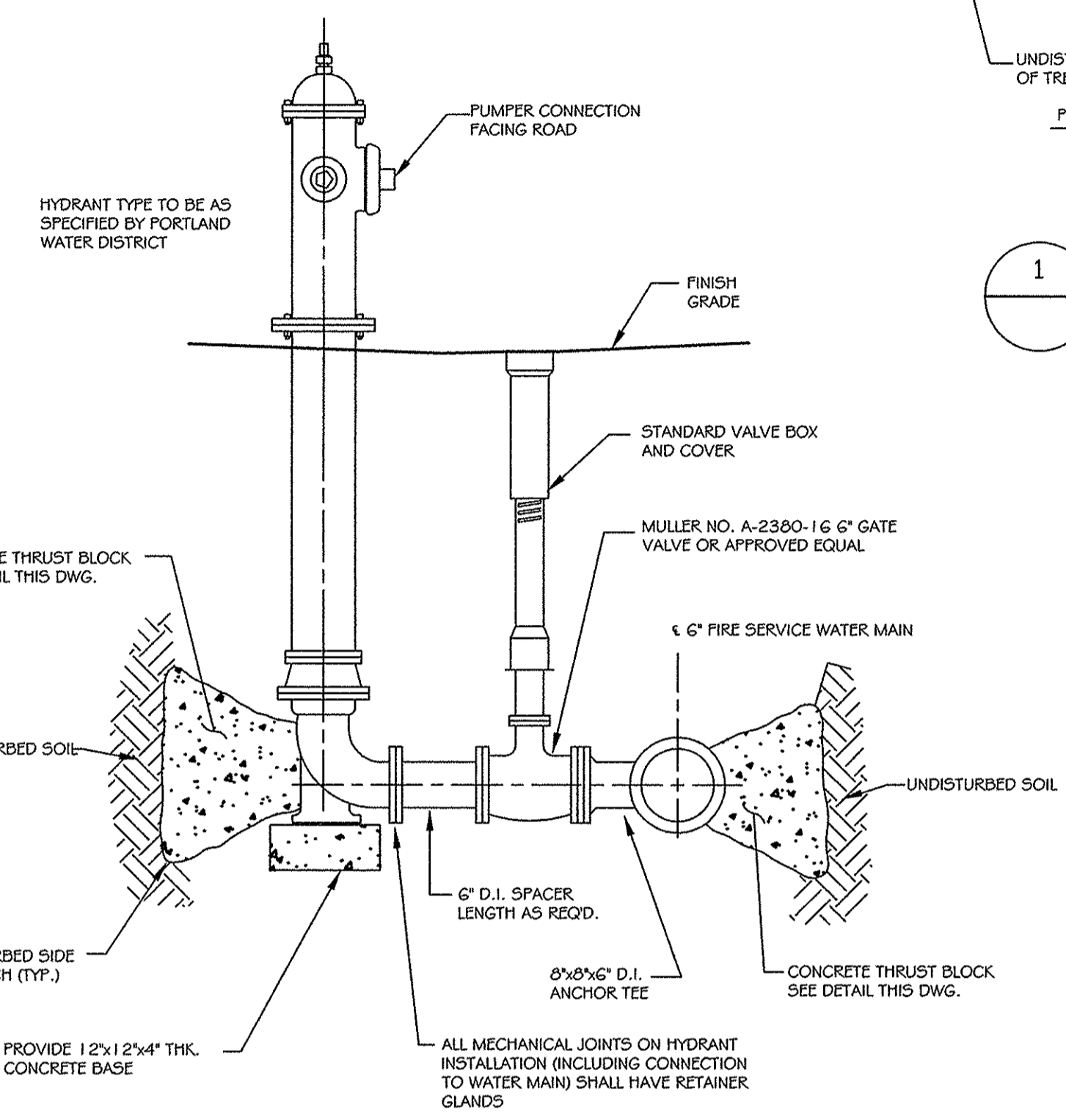

2 HYDRANT DETAIL
NOT TO SCALE

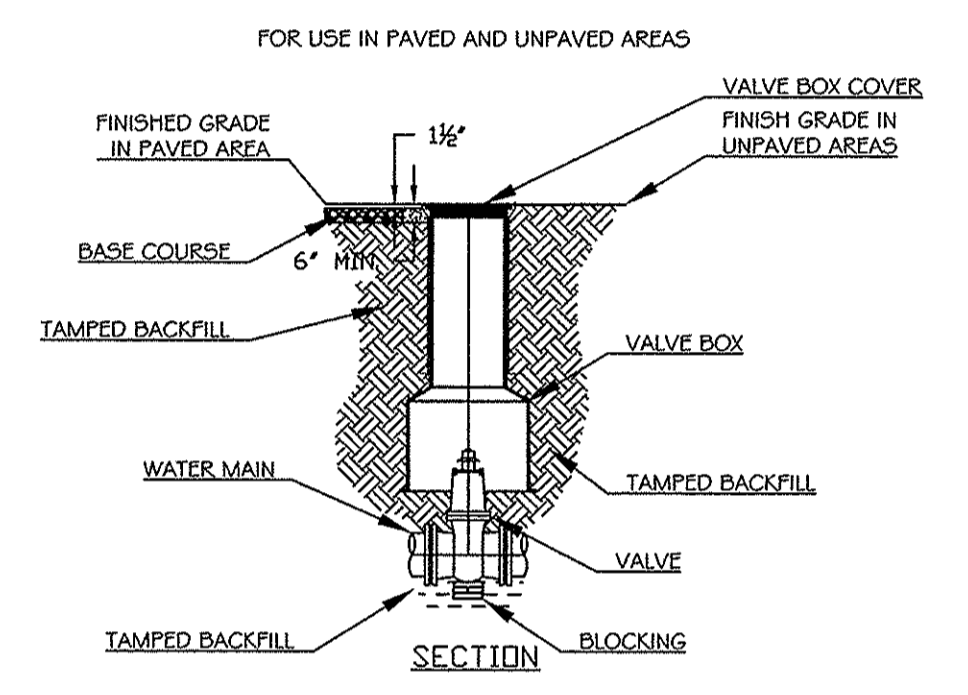

3 VALVE AND VALVE BOX INSTALLATION DETAIL
NOT TO SCALE

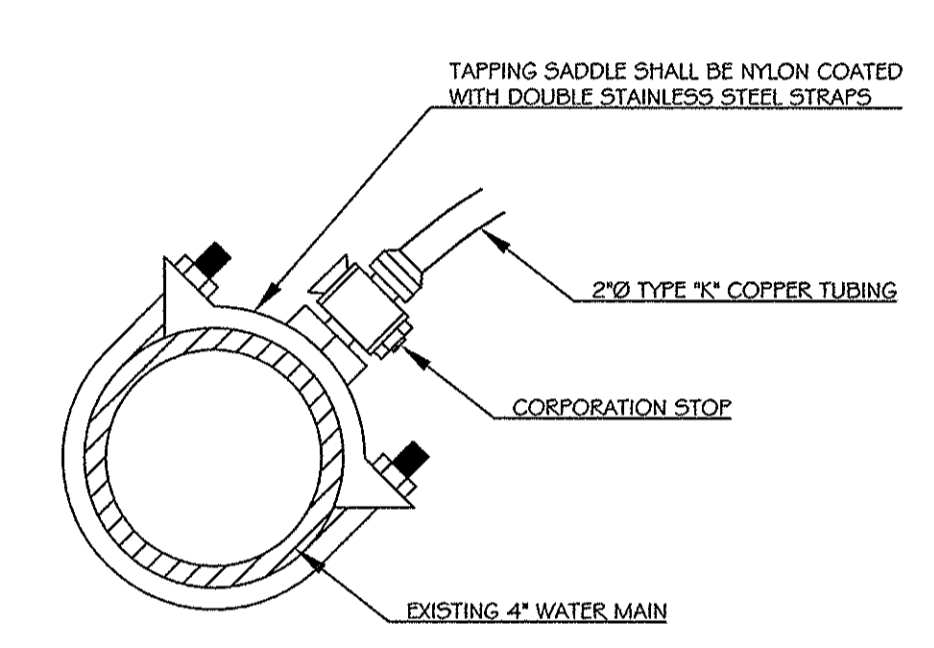

4 STANDARD CORPORATION STOP DETAIL
NOT TO SCALE

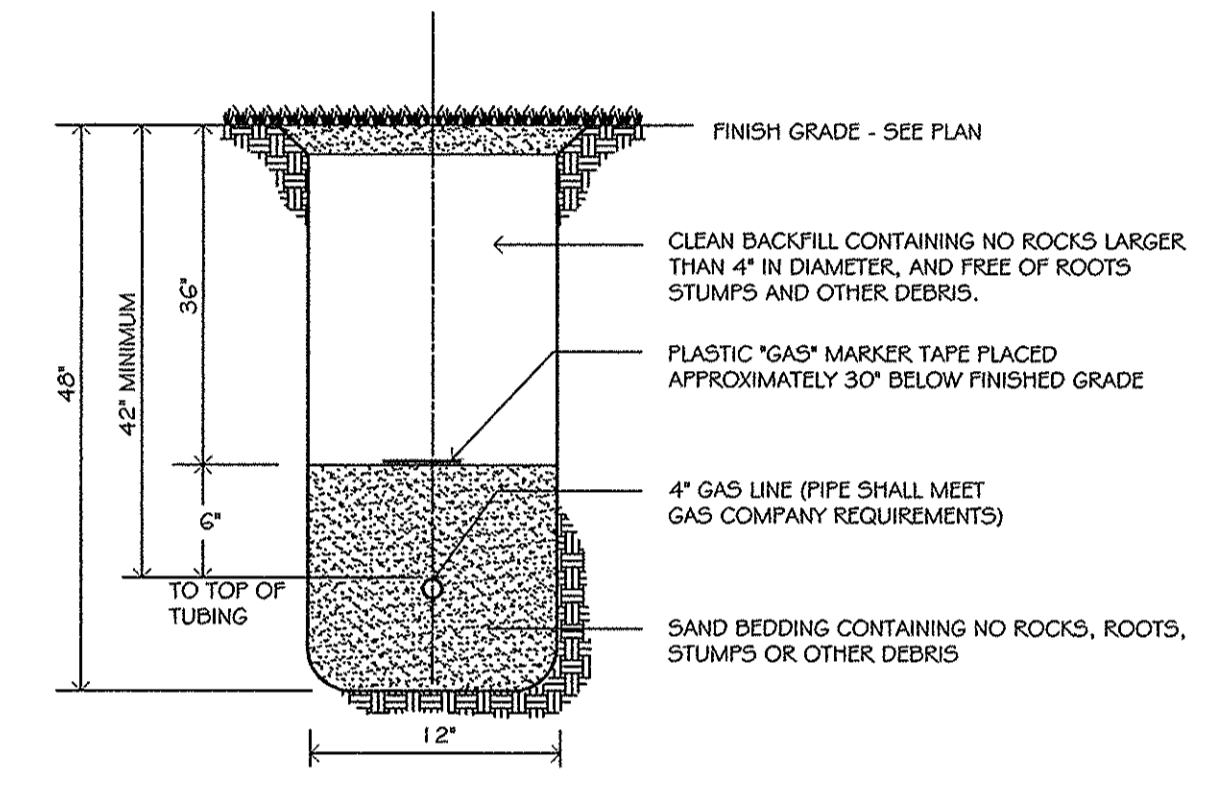

5 NATURAL GAS SERVICE TRENCH SECTION
NOT TO SCALE

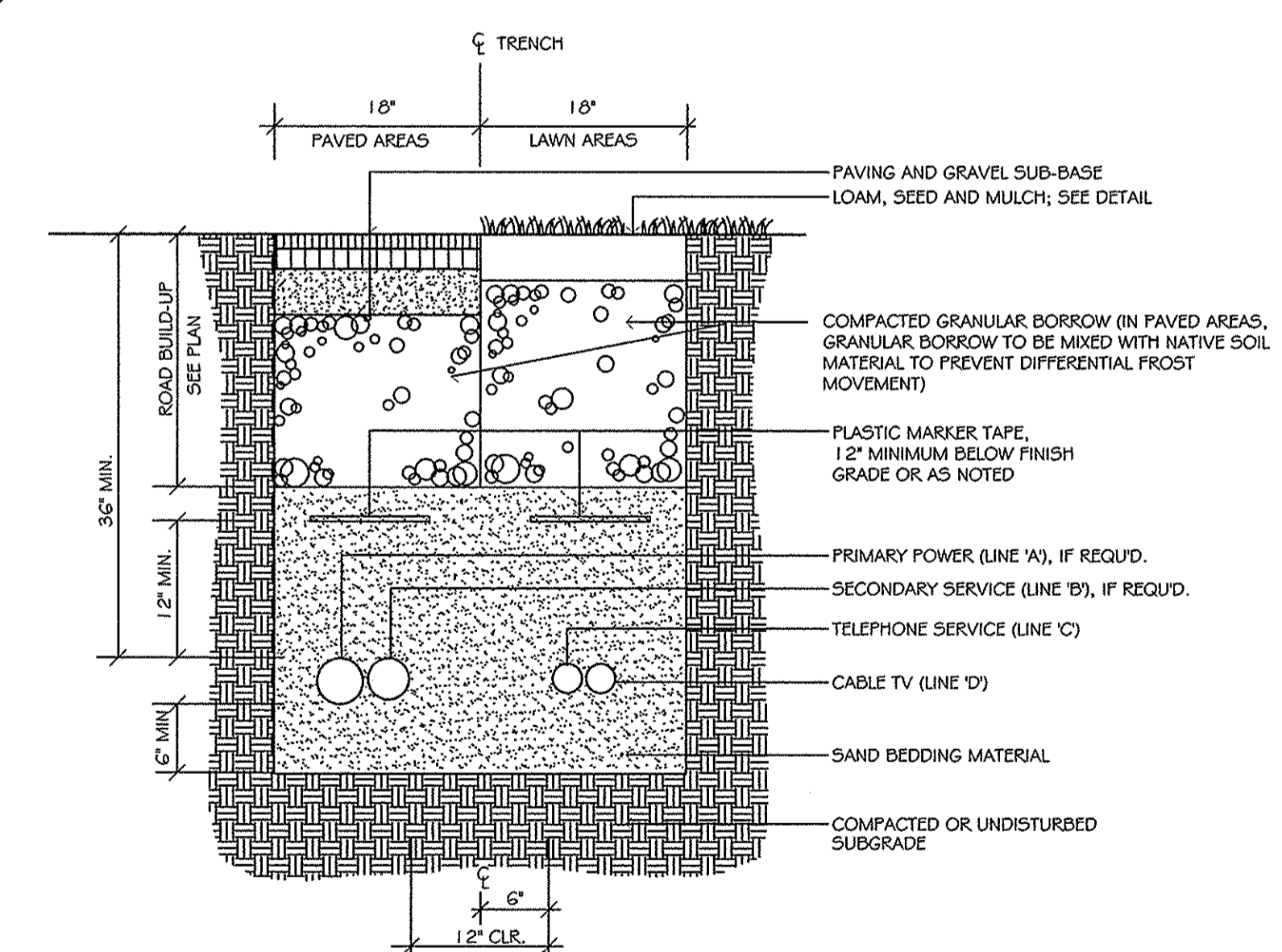

SERVICE	CONDUIT SIZE	CONDUIT TYPE	UTILITY
'A'	5"	SCHEDULE 40 F.V.C. ELECTRICAL GRADE	PRIMARY POWER
'B'	4"	SCHEDULE 40 F.V.C. ELECTRICAL GRADE	SECONDARY POWER
'C'	3"	SCHEDULE 40 F.V.C. ELECTRICAL GRADE	TELEPHONE
'D'	3"	SCHEDULE 40 F.V.C. ELECTRICAL GRADE	CATV

6 UNDERGROUND UTILITY TRENCH SECTION (MULTIPLE CONDUITS)
NOT TO SCALE

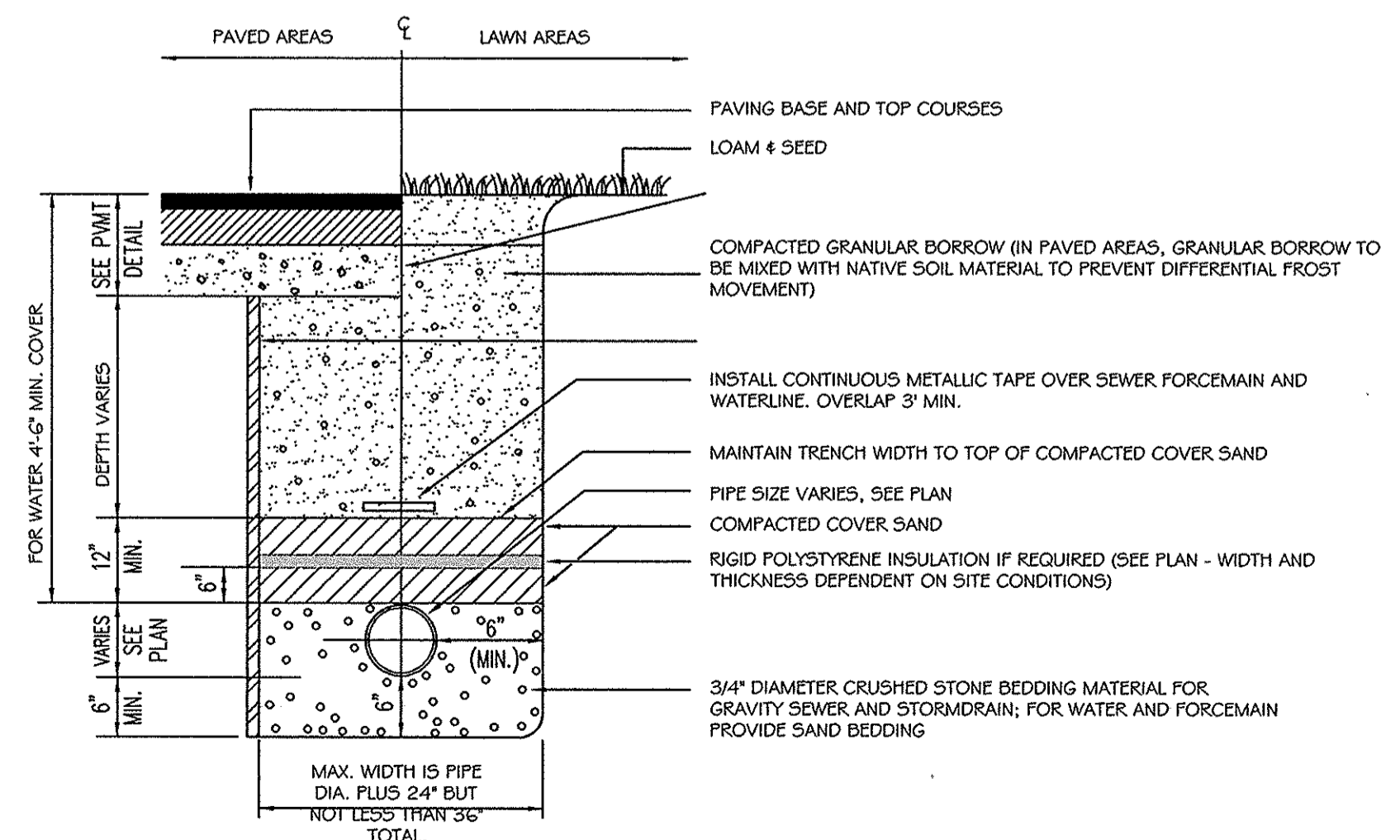

7 TYPICAL PIPE TRENCHING DETAIL
NOT TO SCALE

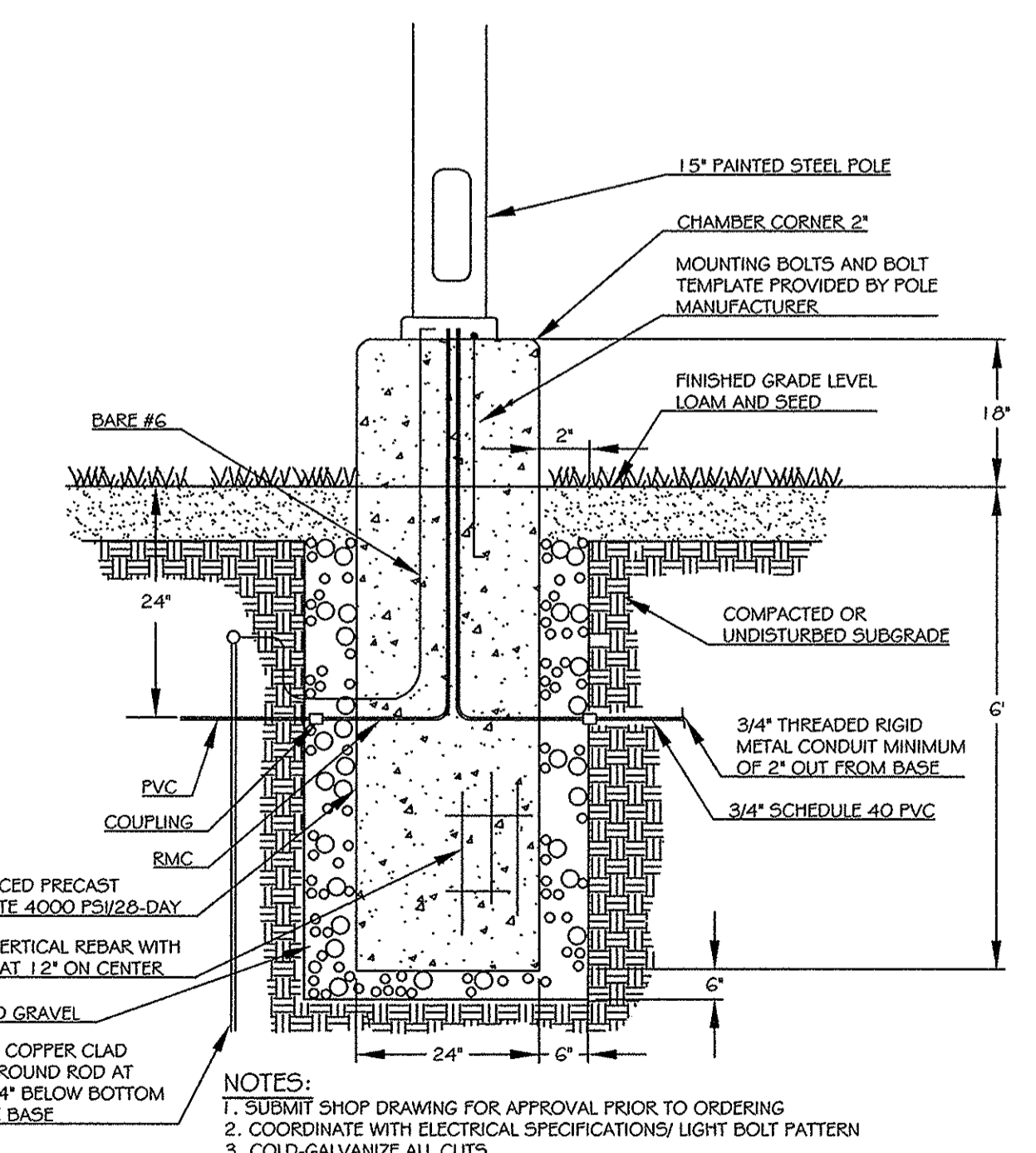

8 CONCRETE POLE BASE DETAIL
NOT TO SCALE

PORTLAND HOTELS, INC.
1200 BRIGHTON AVENUE
PORTLAND, MAINE

DRN BY: JDC
DESG BY: TSG
CHK BY: [Signature]

SCALE: AS SHOWN
DATE: APRIL 4, 2017
PROJECT: 16186

HOTEL REDEVELOPMENT
1210 BRIGHTON AVENUE
PORTLAND, MAINE

SITE DETAILS