

MPC-6000 Intelligent Fire Alarm Panel

Features

- One intelligent Signaling Line Circuit
- SLC loop supports up to 252 addressable Inputs AND signal/relay outputs (504 inputs/outputs total)
- Addressable devices are polarity insensitive
- Devices operate on standard wire-no twist or shield required
- FireSmart Application Specific fire detection
- 4 Class B/2 Class A notification appliance circuits
- Up to 6A NAC Power
- Built in strobe synchronization protocol
- 80 Character backlit LCD display
- Optional Peer-to-Peer networking using MPC-Net
- One man walk test (Silent or Audible)
- Auto Program Feature
- UP to 16 remote LCD Displays with control capabilities
- Programmable from front keypad, or Windows based PC programming software
- Maintenance and technician level passwords
- Optional internal DACT
- 2000 event history log
- Made in the USA, ISO 9001 quality crafted
-  UL 864 , MEA & CSFM Listed

Description

The MPC-6000 is an advanced modular fire alarm panel. It features analog/addressable detection, programming, and memory capability. It's base configuration includes one analog/addressable loop, with four notification appliance output circuits.

Operating controls and indicators are mounted behind a locked cabinet door and an 80-character LCD display provides specific indications for addressable devices, while LEDs indicate general panel status.



MPC-6000

Hardware Configuration

The main termination board mounts in the rear of the panel. The main power supply is physically contiguous with the main termination board. The MPC-6000 main termination board provides the interface for external system connections, the SLC loop interface PCB, four NAC circuits, remote signaling circuits and indicating interfaces.

The front Display Board mounts on a hinged front plate, which is located behind a locked cabinet door. Displays for any number of zones are handled through this board.

All normal operation is controlled from the front of the panel via membrane switches. Displays are provided by an 80-character, alphanumeric, backlit LCD display and by discrete LED indicators for major panel functions.

The 80-character LCD display is used to display event data, including alarms and troubles, supervisory identification of zone or device, and presentation of history. The menus are controlled by a set of four membrane switches commanding the control processor. A back light is included to assure visibility in low light, but to conserve power, it is only activated during a reported event.

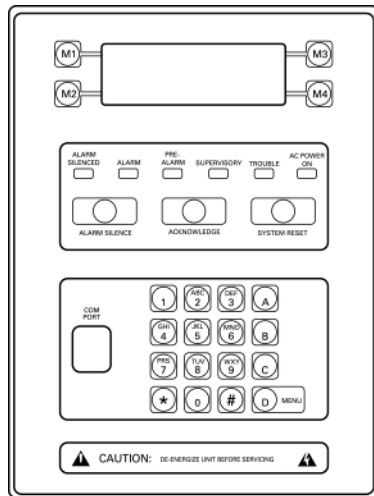

Minimum Control Unit Configuration

- A. Intelligent Signaling Line Circuit – The main termination board has addressable loop interface circuitry supporting one SLC loop. Devices are polarity insensitive and can operate on untwisted, unshielded wire.
- B. Notification Appliance Circuits –The base panel has four independent NACs. Each circuit can be selected to give continuous output, one of eight sounding patterns. NACs are style Z or Y capable, without additional modules.
- C. Dry Contacts – Four programmable form “C” dry relay contacts are provided.
- D. Remote Annunciation –The MPC-6000 panel will drive up to 16 annunciators and 8 remote processors on an RS-485 communication line.
- E. Power Supply – A 7A, 24V nominal power supply provides all operating power to the panel for both standby and alarm conditions.

Auxiliary Devices

- A. Remote LCD Annunciator (RDC-2) –The remote LCD annunciator consists of a backlit 80 character, alphanumeric display, 4 menu buttons, 4 dedicated buttons for operator interaction, 6 LED indicators, and a security key switch.
- B. Serial Annunciator (SLU-2) – Consists of one remote processor and one annunciator driver board capable of providing 16 supervised outputs for LEDs or incandescent lamps. Expansion to drive 512 LEDs or lamps is via additional processor boards and annunciator drive boards (SLE-16).
- C. Serial Relay Unit (SRU-2) – Consists of remote processor and relay board which provides 8 relays with form “C” dry contacts rated at 1 amp. Expansion to 192 relays is via additional remote processor boards and relay boards (SLE-8).

Optional Control Unit Configuration

- A. MPC-DACT – The MPC-DACT provides a dual line digital alarm communications transmitter. It’s parameters are set via the control unit programming sequence.

The MPC-DACT is compatible with the following formats: SIA DCS 8, SIA DCS 20, Ademco Contact ID, 3/1 1400 Hz., 3/1 2300 Hz.,

Wiring, Main Termination Board

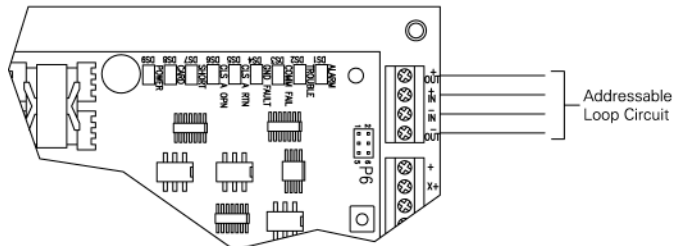

Addressable Device Circuit
 Style 4 or 6 Operation
 24VDC nominal
 Wire Resistance-50 ohms max
 (see Line Resistance Graph)
 Supervised, Power Limited
 See Owner's Manual for Compatible Devices

NAC Rating:
 Alarm Voltage: 24V FW nominal
 Max. Alarm Current: 1.5A/NAC circuit
 Max. Ripple: 16VAC
 Max. Wire Voltage Drop: 1.0VDC
 Max. Standby Current: 1.0mA

NOTE:
 The maximum total current for the MPC-6000 NACs is 3.0A and 6.0A with the optional additional Transformer P/N NPE-1

Typical Notification Appliance Circuit Style Z, Class A
 Supervised, Power Limited
 See Owners Manual for Compatible Devices

Typical Notification Appliance Circuit Style Y, Class B
 Supervised, Power Limited
 See Owners Manual for Compatible Devices

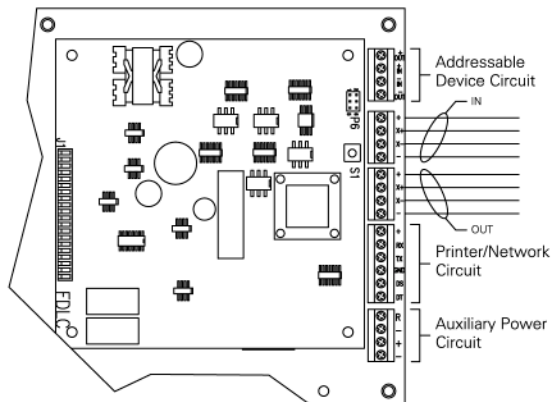
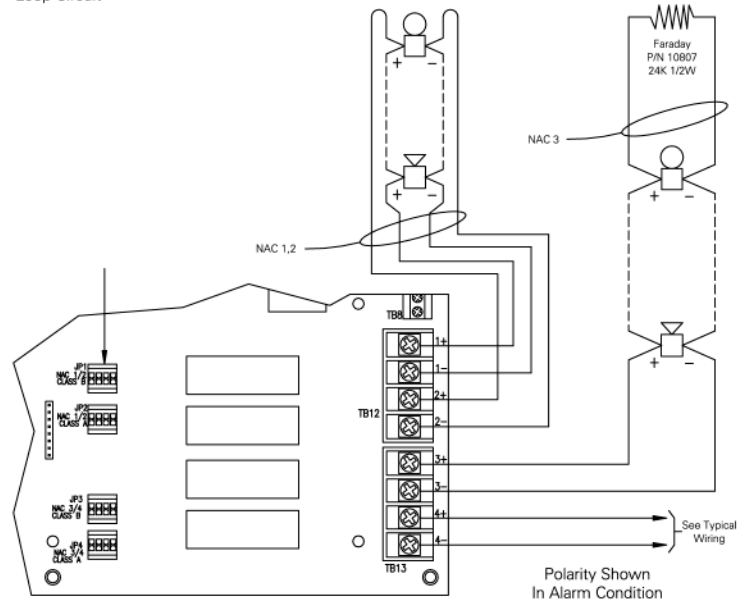

Serial Interface Circuit,
 (=, -) 24VDC nominal, 0.4 max
 (X+, X-) RS-485 levels
 Wire Type-Twisted Pair For Data
 Wire Resistance-11 ohms/line (4000' max)
 Supervised, Power Limited,
 See Owner's Manual for
 Compatible Devices.

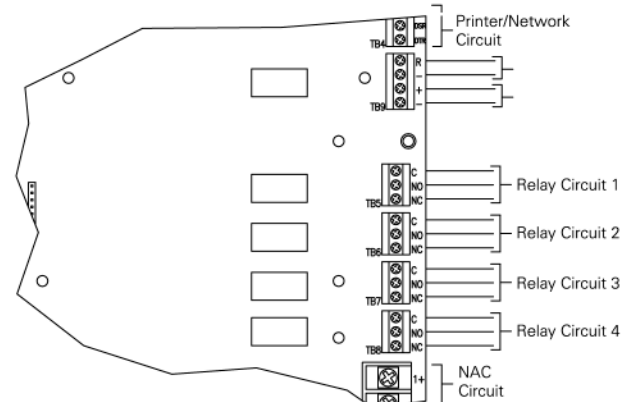

Auxiliary Power Outputs
 0.4A max. @24VDC nominal
 Unsupervised, Power Limited
 Maximum current of all auxiliary outputs
 circuits, Serial Interface Circuit and
 option boards is: 0.5A for the 6000
 1.0 A for the 7000

Status Relay Contacts
 (Shown in normal standby condition)
 1A 28VDC max Resistive For Power
 Limited Source, Unsupervised

General Specifications

Environmental

Operating temperature: 32-120°F (0-49°C)
 Relative Humidity - 85% @ 86°F

Primary Supply

Primary input voltage -
 120 Vac (50/60 Hz.), 240 Vac (50/60 Hz.)
 Maximum primary input current -
 1.3 amp @ 120 Vac

Secondary and Trouble Power Supply

24 volt lead-acid battery with 7 AH-38 AH capacity

Auxiliary Power Outputs

Current - 0.5 amp resettable/non-resettable
 power outputs

Status System Relays

4 relays rated @ 1 amp, 28 Vdc resistive

NAC Circuits

Rating per NAC circuit, 1.5A ea., 6 max.

Battery

Base cabinet will accommodate a 10 A battery
 set. Larger batteries will require separate enclosure

Dimensions

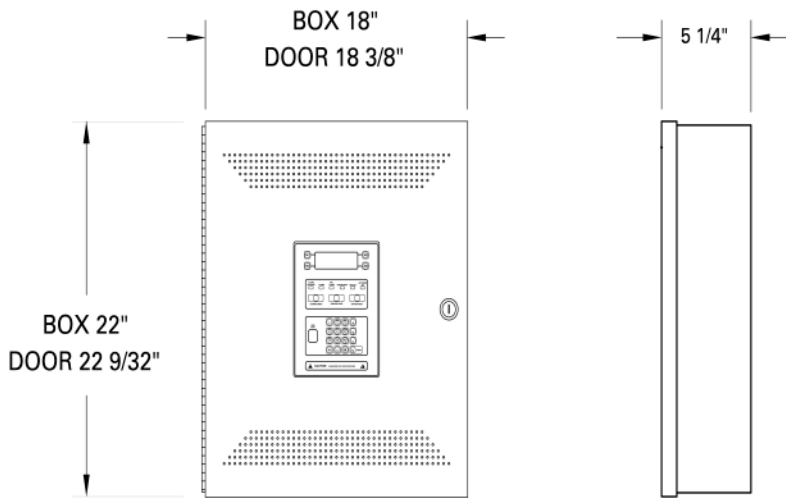

Ordering Information

Model	Description	Part No.
MPC-6000	MPC-6000 Single Loop Addressable Fire Alarm Panel, Red	599-049304FA
MPC-6000B	MPC-6000 Single Loop Addressable Fire Alarm Panel, Black	599-049303FA
Options		
RDC-2	Remote Annunciator	500-648980FA
NPE-1	Transformer to expand NAC power	500-649120FA
SRU-2	RS-485 Relay Card	500-649308FA
SRE-8	8 Relay Extender	500-649337FA
SLU-2	RS-485 LED Driver Card (16 Outputs)	500-649307FA
SLE-16	16 LED Driver Extender	500-649339FA
FAE-21	ACC. Enclosure for RS-485 Devices	500-401403014FA
MPC-DACT	Dialer for MPC-6000 and MPC-7000	500-649330FA
CT-1K	CityTie Module for MPC-6000 and MPC-7000	500-649336FA
SFTK-6R	Semi-Flush Trim for MPC-6000, Red	500-648955FA
SFTK-6B	Semi-Flush Trim for MPC-6000, Black	500-648954FA



Siemens Building Technologies, Inc.
 8 Fernwood Road • Florham Park, NJ 07932
 Tel: (973) 593-2600 • Fax: (973) 593-6670
 Web: www.faradayfirealarms.com

WARNING - The information contained in this document is intended only as a summary and is subject to change without notice. The devices described in this document have specific instruction sheets which cover various technical, limitation and liability information. Copies of these instruction sheets and the General Product Warning and Limitations Document, which also contains important information, are provided with the product and are available from the Manufacturer. Information contained in these documents should be consulted before specifying or using the product. For further information or assistance concerning particular problems contact the Manufacturer.