

1 INTERIOR ELEVATION  
1/4" = 1'-0"  
STORAGE

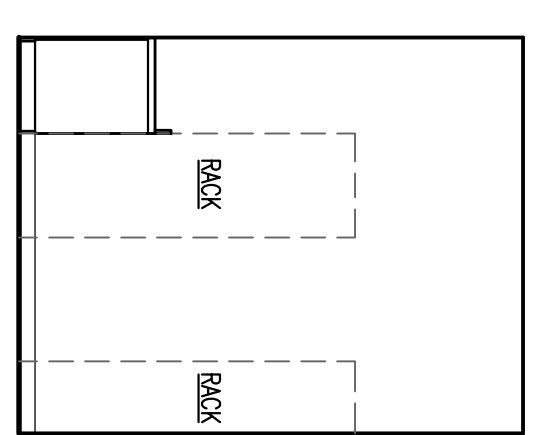

2 INTERIOR ELEVATION  
1/4" = 1'-0"  
STORAGE

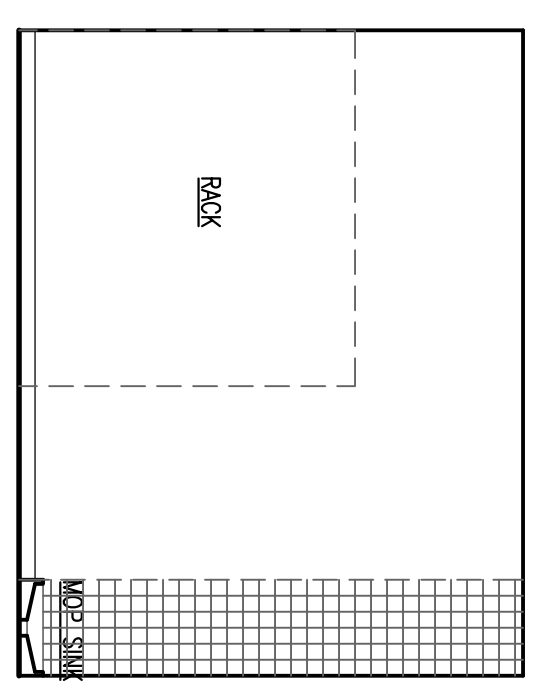

3 INTERIOR ELEVATION  
1/4" = 1'-0"  
STORAGE

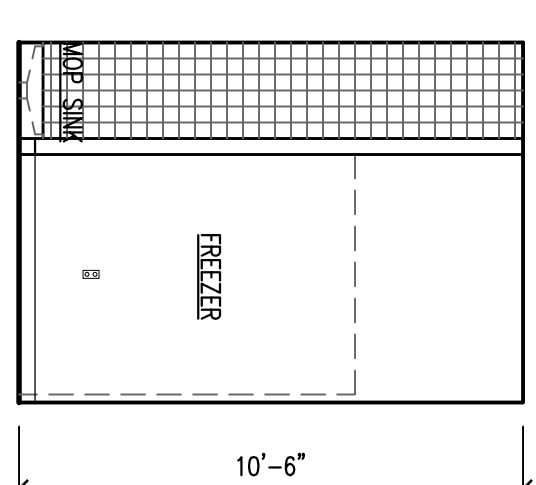

4 INTERIOR ELEVATION  
1/4" = 1'-0"  
STORAGE



5 INTERIOR ELEVATION  
1/4" = 1'-0"  
STORAGE

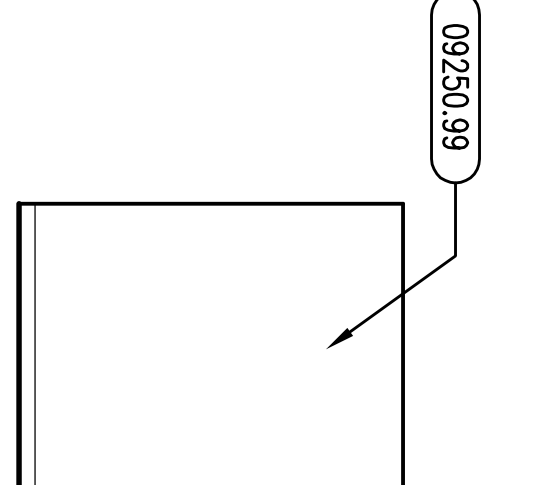

6 INTERIOR ELEVATION  
1/4" = 1'-0"  
OFFICE

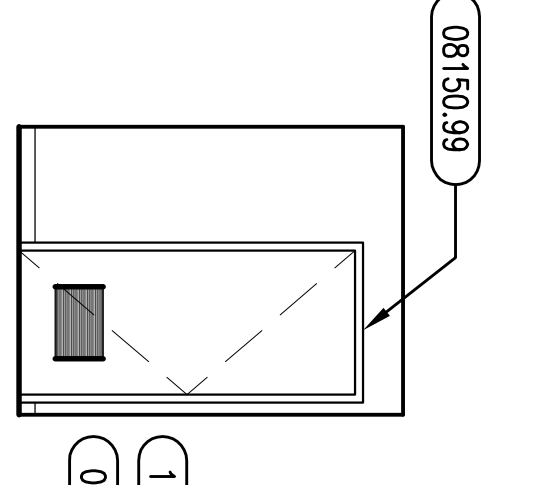

7 INTERIOR ELEVATION  
1/4" = 1'-0"  
OFFICE

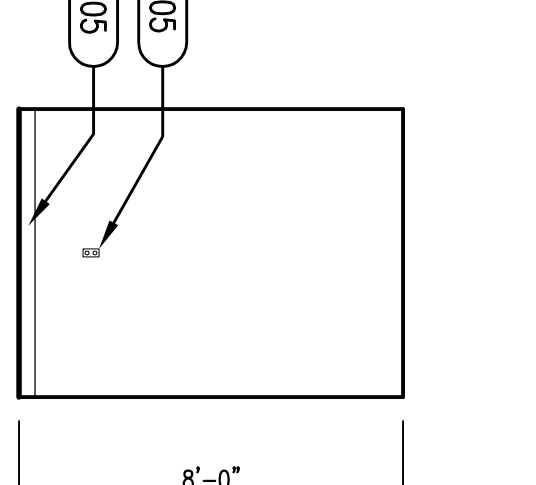

8 INTERIOR ELEVATION  
1/4" = 1'-0"  
OFFICE

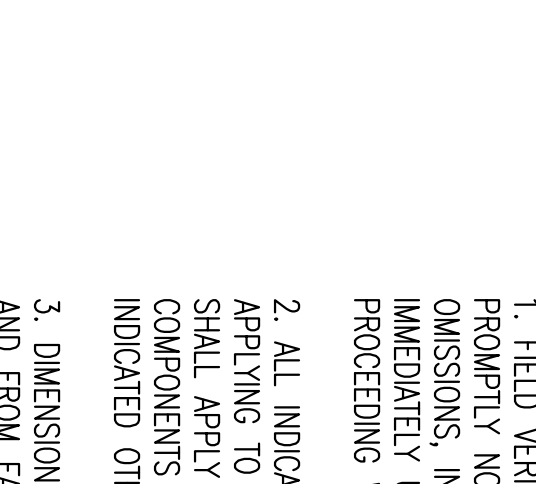

9 INTERIOR ELEVATION  
1/4" = 1'-0"  
OFFICE

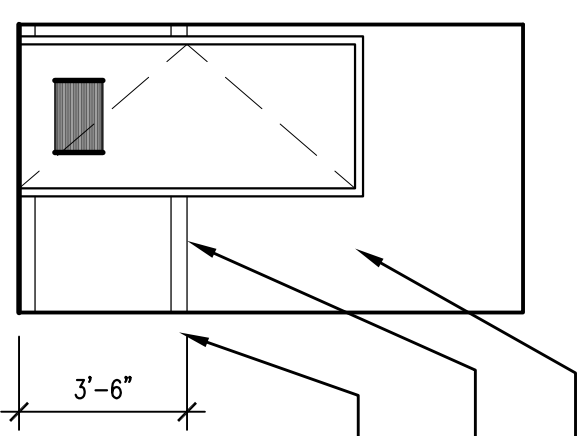

10 INTERIOR ELEVATION  
1/4" = 1'-0"

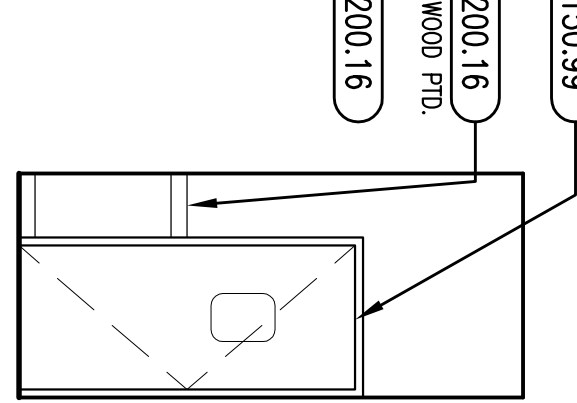

11 INTERIOR ELEVATION  
1/4" = 1'-0"

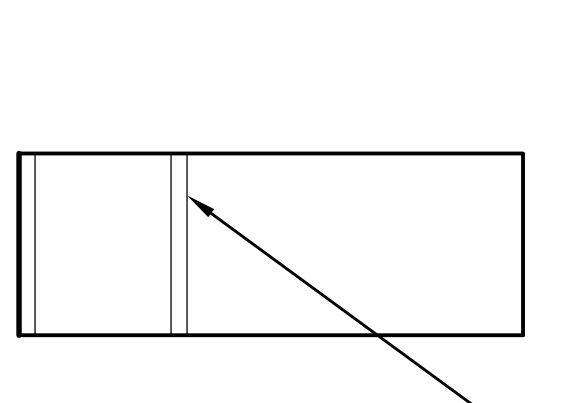

12 INTERIOR ELEVATION  
1/4" = 1'-0"

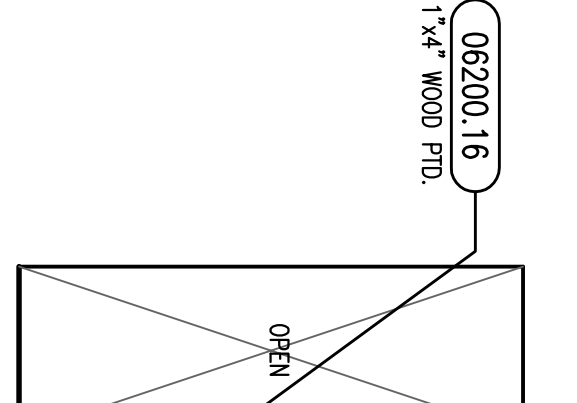

13 INTERIOR ELEVATION  
1/4" = 1'-0"

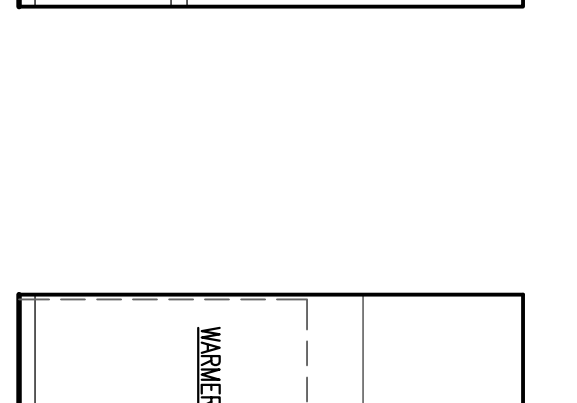

14 INTERIOR ELEVATION  
1/4" = 1'-0"  
KITCHEN

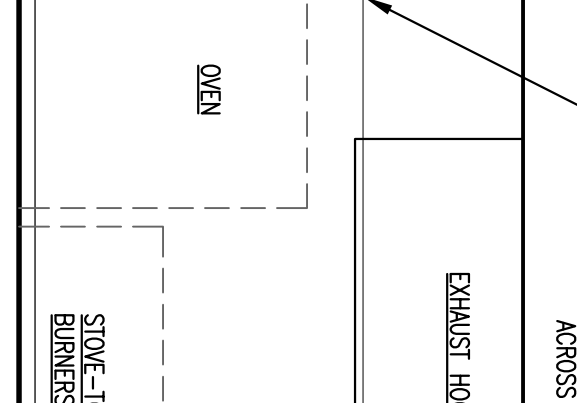

15 INTERIOR ELEVATION  
1/4" = 1'-0"  
KITCHEN

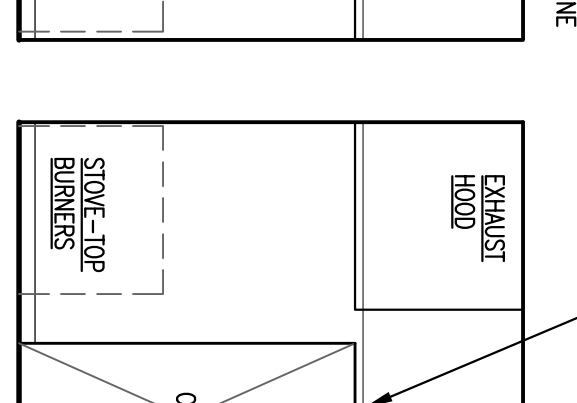

16 INTERIOR ELEVATION  
1/4" = 1'-0"  
KITCHEN

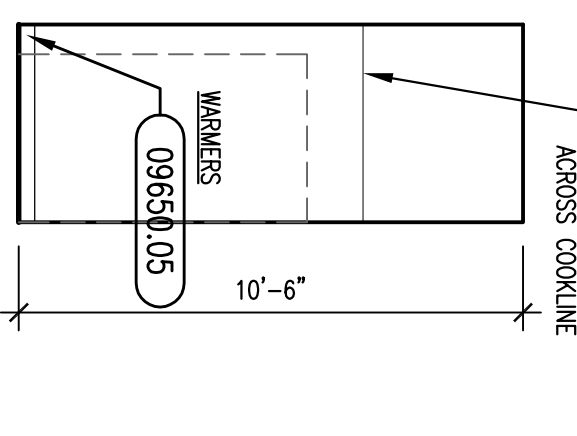

17 INTERIOR ELEVATION  
1/4" = 1'-0"  
KITCHEN

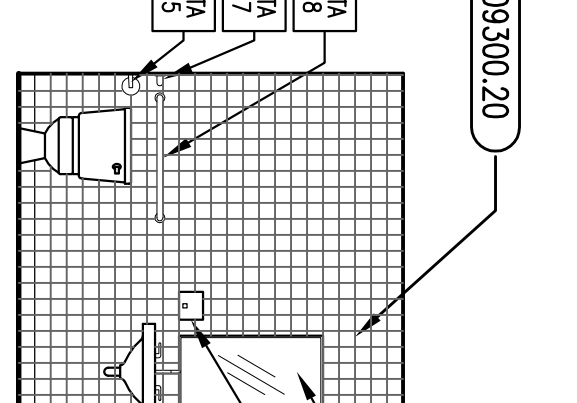

18 INTERIOR ELEVATION  
1/4" = 1'-0"  
MEN - WOMEN O.H.

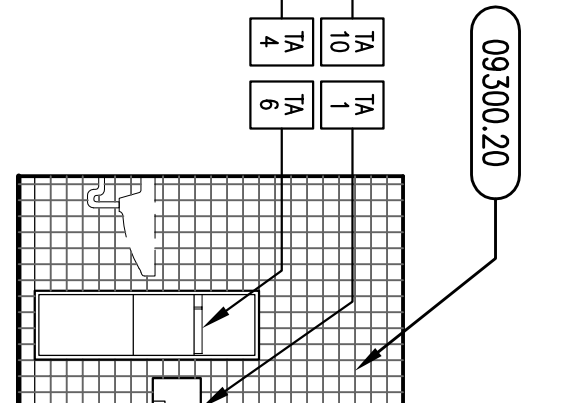

19 INTERIOR ELEVATION  
1/4" = 1'-0"  
MEN - WOMEN O.H.

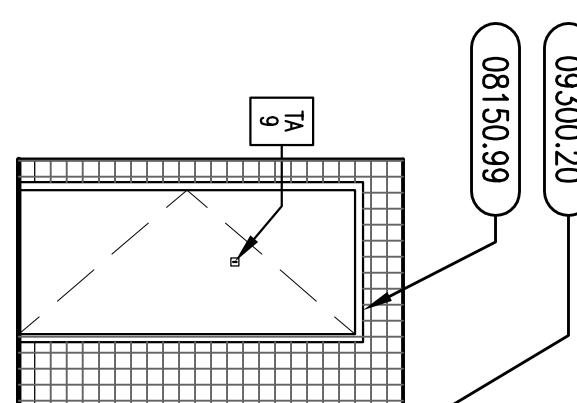

20 INTERIOR ELEVATION  
1/4" = 1'-0"  
MEN - WOMEN O.H.

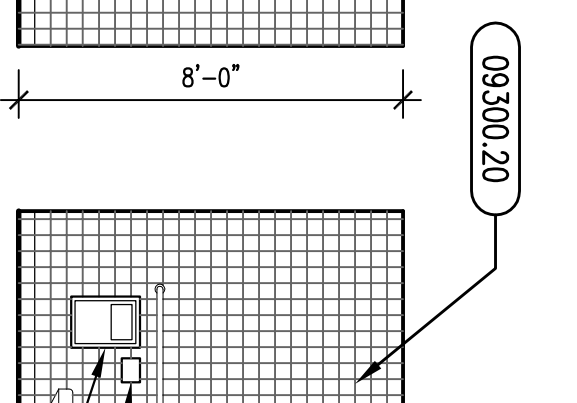

21 INTERIOR ELEVATION  
1/4" = 1'-0"  
MEN - WOMEN O.H.

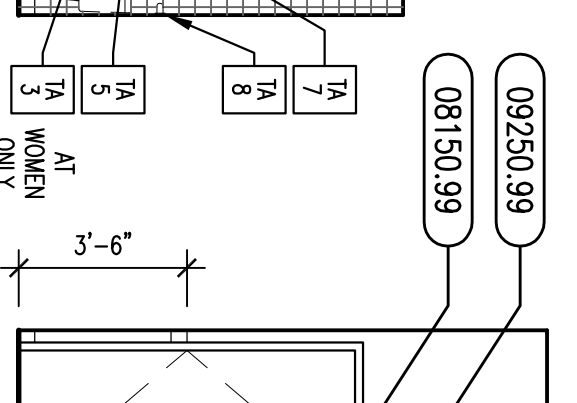

22 INTERIOR ELEVATION  
1/4" = 1'-0"  
COMBODR

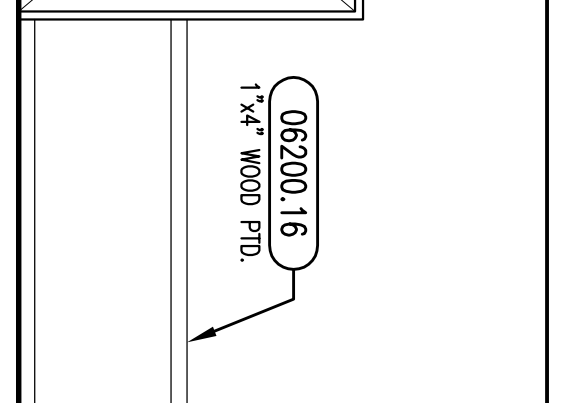

23 INTERIOR ELEVATION  
1/4" = 1'-0"  
COMBODR

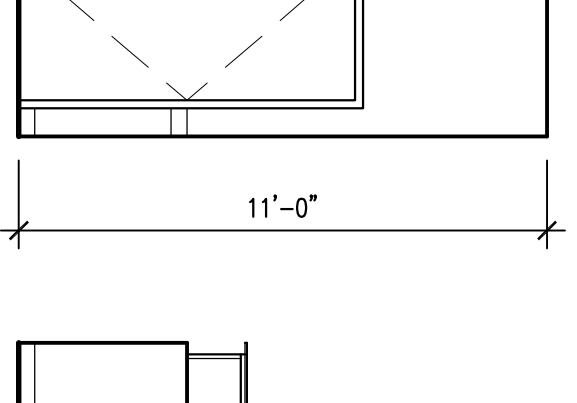

24 INTERIOR ELEVATION  
1/4" = 1'-0"  
COMBODR

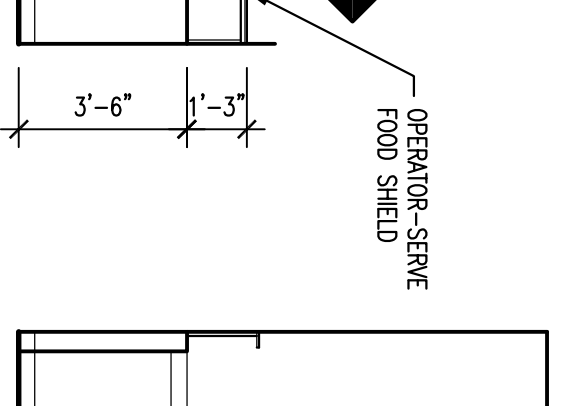

25 INTERIOR ELEVATION  
1/4" = 1'-0"  
COMBODR

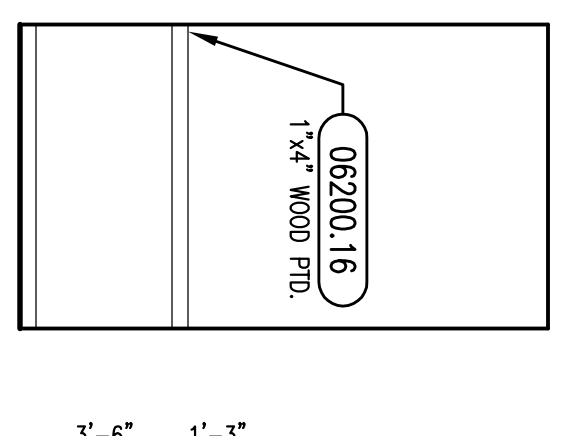

26 INTERIOR ELEVATION  
1/4" = 1'-0"

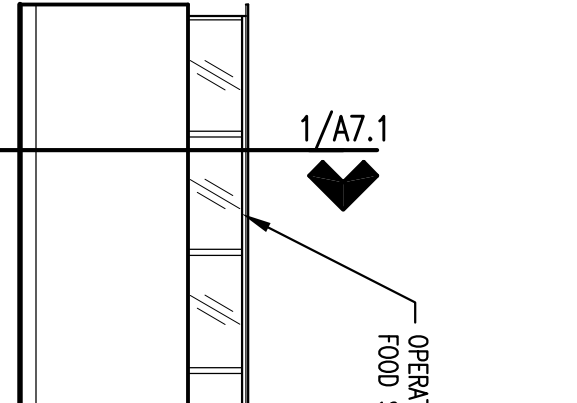

27 INTERIOR ELEVATION  
1/4" = 1'-0"

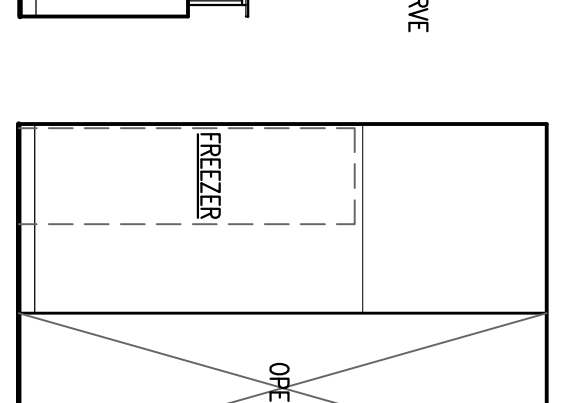

28 INTERIOR ELEVATION  
1/4" = 1'-0"  
STAIRW

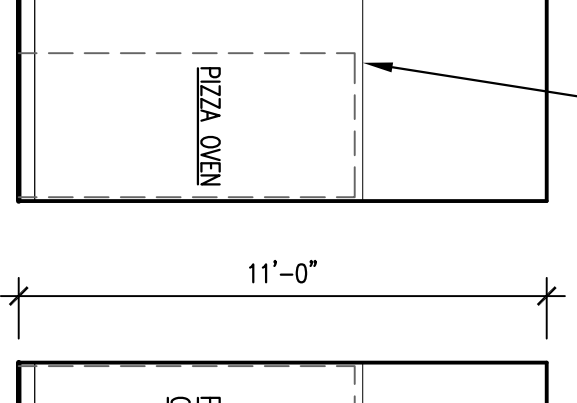

29 INTERIOR ELEVATION  
1/4" = 1'-0"  
STAIRW

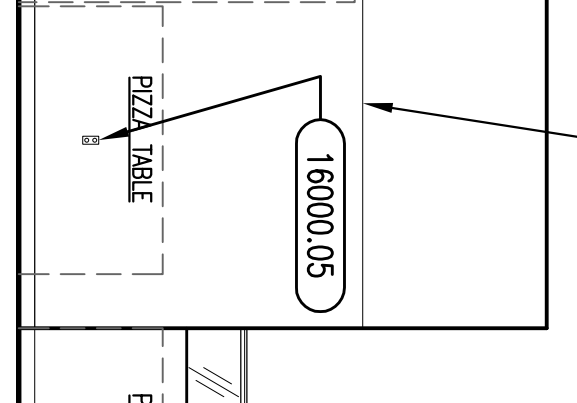

30 INTERIOR ELEVATION  
1/4" = 1'-0"

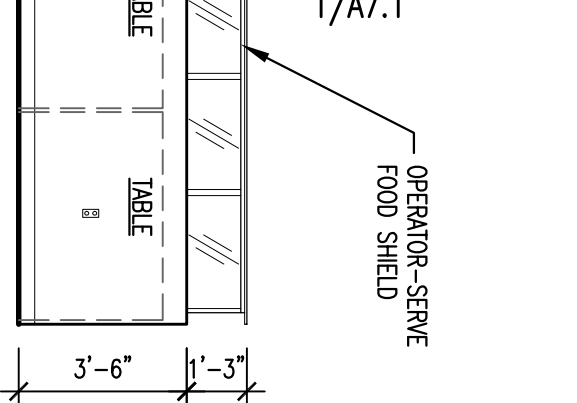

31 INTERIOR ELEVATION  
1/4" = 1'-0"

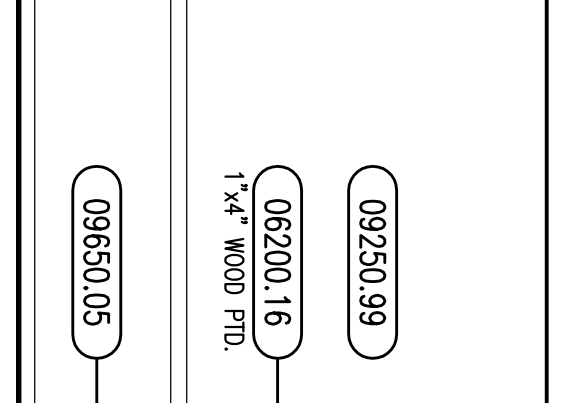

32 INTERIOR ELEVATION  
1/4" = 1'-0"

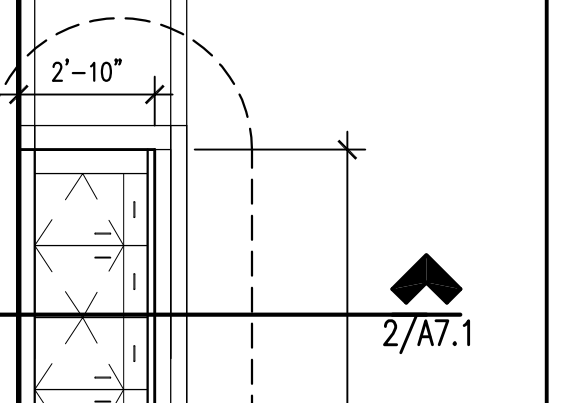

33 INTERIOR ELEVATION  
1/4" = 1'-0"

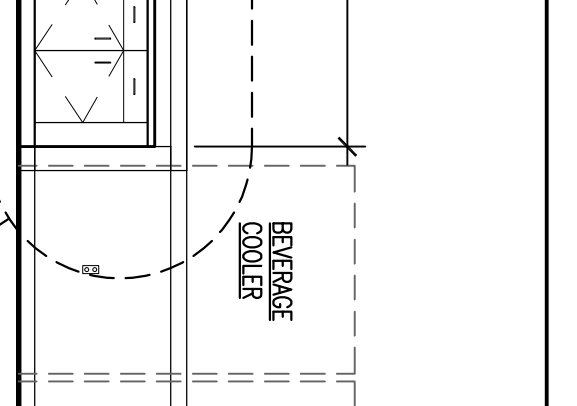

34 INTERIOR ELEVATION  
1/4" = 1'-0"

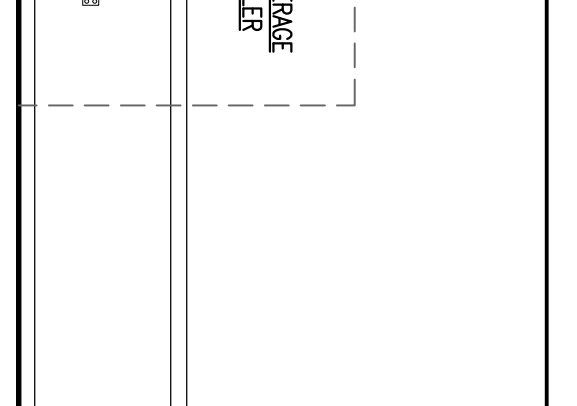

35 INTERIOR ELEVATION  
1/4" = 1'-0"

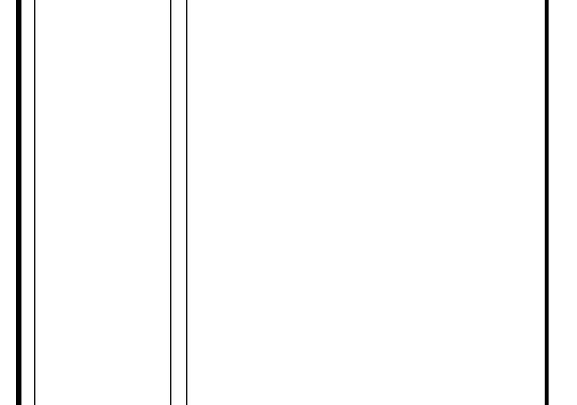

36 INTERIOR ELEVATION  
1/4" = 1'-0"



37 INTERIOR ELEVATION  
1/4" = 1'-0"  
STAIRW

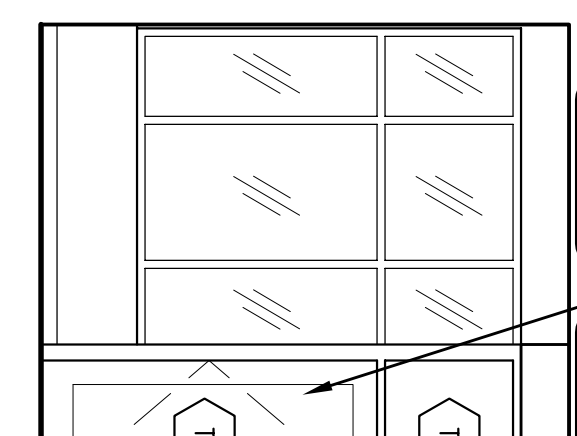

38 INTERIOR ELEVATION  
1/4" = 1'-0"  
STAIR W/VESTIB

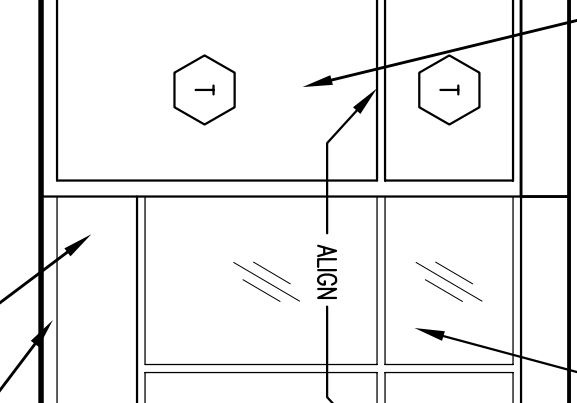

39 INTERIOR ELEVATION  
1/4" = 1'-0"  
STAIRW AREA

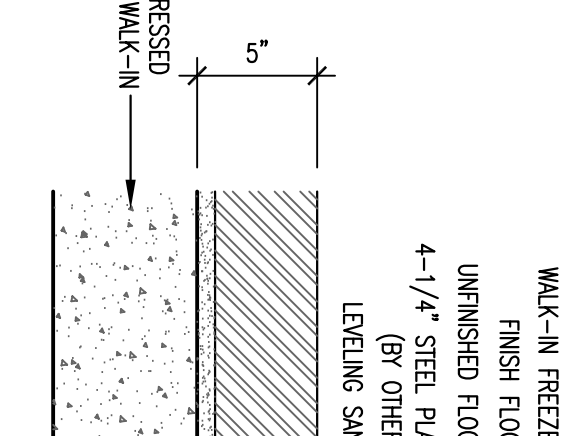

40 EXCAVATION DETAIL  
1"-1/2" = 1'-0"  
AT WALK-IN FREEZER ONLY

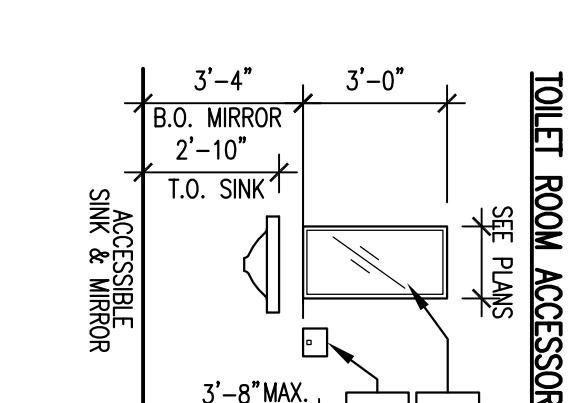

TOILET ROOM ACCESSORY MOUNTING HEIGHTS

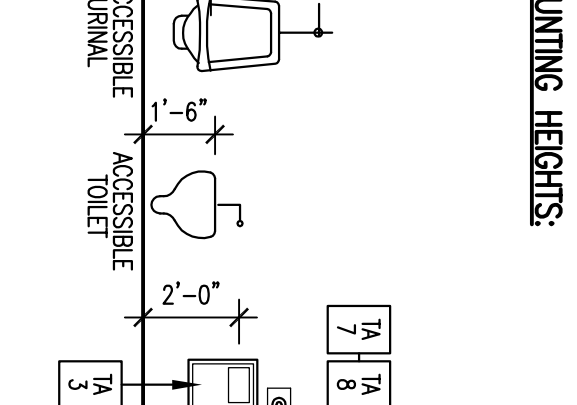

TOILET ACCESSORIES

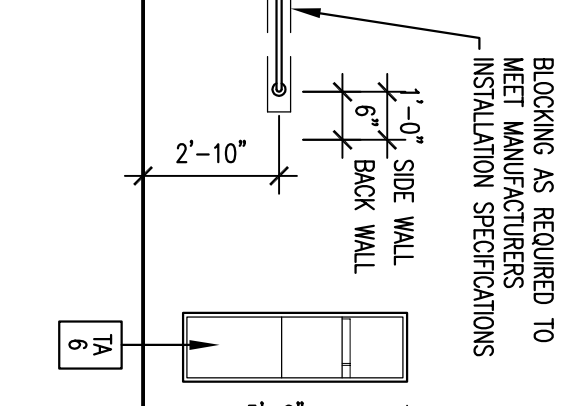

TOILET ACCESSORIES

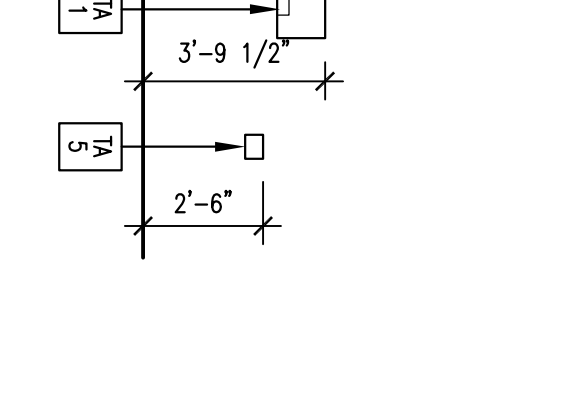

TOILET ACCESSORIES



TOILET ACCESSORIES



TOILET ACCESSORIES



TOILET ACCESSORIES



TOILET ACCESSORIES



TOILET ACCESSORIES



TOILET ACCESSORIES



TOILET ACCESSORIES



TOILET ACCESSORIES

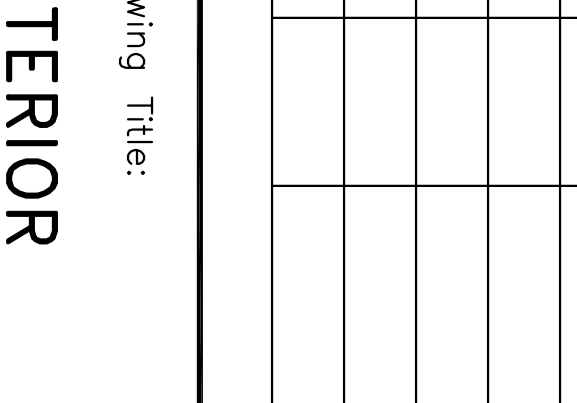

TOILET ACCESSORIES

GENERAL NOTES:

- FIELD VERIFY ALL DIMENSIONS AND CONDITIONS. REPORTED NOTIFY THE ARCHITECT OF ANY ERRORS, OMISSIONS, INCONSISTENCIES OR OTHER PROBLEMS IMMEDIATELY UPON DISCOVERY, AND BEFORE PROCEEDING WITH THE WORK.
- ALL INDICATIONS AND NOTATIONS ON THE DRAWINGS APPLY TO ONE AREA, COMPONENT, OR CONDITION UNLESS OTHERWISE NOTED. ALL OTHER SIMILAR AREAS, COMPONENTS OR CONDITIONS, UNLESS CLEARLY INDICATED OTHERWISE.
- DIMENSIONS ARE TAKEN FROM COLUMN CENTER LINES AND FROM FACE OF STUDY CLEAR DIMENSIONS ARE TO FACE UNLESS NOTED OTHERWISE.
- MECHANICAL, ELECTRICAL, FIRE PROTECTION, PLUMBING ARE DESIGN/ BUILD AND ARE TO BE PROVIDED AND COORDINATED BY THE GENERAL CONTRACTOR AND OWNER.
- NOTE: GENERAL CONTRACTOR TO COORDINATE ALL UTILITY REQUIREMENTS AND LOCATIONS TO BACK OF BUILDING FOR EACH TRADE AND BUILDING DRAINAGE.
- NOTE: GENERAL CONTRACTOR TO COORDINATE ELECTRICAL TRANSDUCER LOCATION WITH UTILITY COMPANY.
- NOTE: GC TO COORDINATE LOCATION OF HOUSE ELECTRICAL PANEL.

GENERAL FINISH NOTES:

- FIELD VERIFY ALL DIMENSIONS AND CONDITIONS. REPORTED NOTIFY THE ARCHITECT OF ANY ERRORS, OMISSIONS, INCONSISTENCIES OR OTHER PROBLEMS IMMEDIATELY UPON DISCOVERY, AND BEFORE PROCEEDING WITH THE WORK.
- ALL INDICATIONS AND NOTATIONS ON THE DRAWINGS APPLY TO ONE AREA, COMPONENT, OR CONDITION UNLESS OTHERWISE NOTED. ALL OTHER SIMILAR AREAS, COMPONENTS OR CONDITIONS, UNLESS CLEARLY INDICATED OTHERWISE.
- DIMENSIONS ARE TAKEN FROM FACE OF FINISHED CONSTRUCTION UNLESS OTHERWISE NOTED. DIMENSIONS ARE TO FACE UNLESS OTHERWISE NOTED. DIMENSIONS ARE TO FACE UNLESS OTHERWISE NOTED.
- GRAB BAR AND ADJACENT SURFACE SHALL BE FREE OF ANY SHARP OR OTHERWISE ABRASIVE ELEMENTS.
- ALL GYPSUM WALL BOARD TO BE 5/8" TYPE "X", EXCEPT AS FOLLOWS: IN TOILET ROOMS, KITCHEN AREAS AND ALL WALLS TO RECEIVE THE SAME SHALL BE 5/8" TYPE "X" MOISTURE RESISTANT GYPSUM WALL BOARD AND FIBER REINFORCED CEMENT WALL BOARD TO BE USED AS THE BACKER AT WET AREAS INCLUDING SHOWERS AND WET JANITOR ROOMS.
- GYPSUM WALL BOARD TO EXTEND TO UNDERSIDE OF BEAM AT ALL BEAM WALLS AND AT NON BEAM WALL EXCEPT AS FOLLOWS: WHERE CEILINGS OCCUR AT NON-BEAM WALLS GYPSUM WALL BOARD TO EXTEND 6" ABOVE CEILING.
- PROVIDE 20 GA. CONTINUOUS SHEET METAL BACKING FOR MIRRORS, AND TOILET ACCESSORIES AS REQUIRED TO MEET MANUFACTURERS INSTALLATION SPECIFICATIONS AND APPLICABLE CODE. SHEET METAL MUST EXTEND OVER 3 STUDS MIN.

KEYNOTES:

- 08200.16 WOOD CHAIR RAIL
- 08150.99 DOOR AND FRAME AS SCHEDULED
- 08410.42 CLEAR TEMPERED GLASS - 1/4"
- 08410.99 ALUMINUM STOREFRONT SYSTEM
- 09250.99 FINISH AS SCHEDULED
- 09300.20 QUARTZ CEMENT WALL TILE
- 09300.05 4" VINYL CODE BASE
- 16000.05 ELECTRICAL OUTLET



**FULL BELLY DELI**  
**PINE TREE SHOPPING CENTER**  
**PORTLAND, ME**

**PERMIT SET**

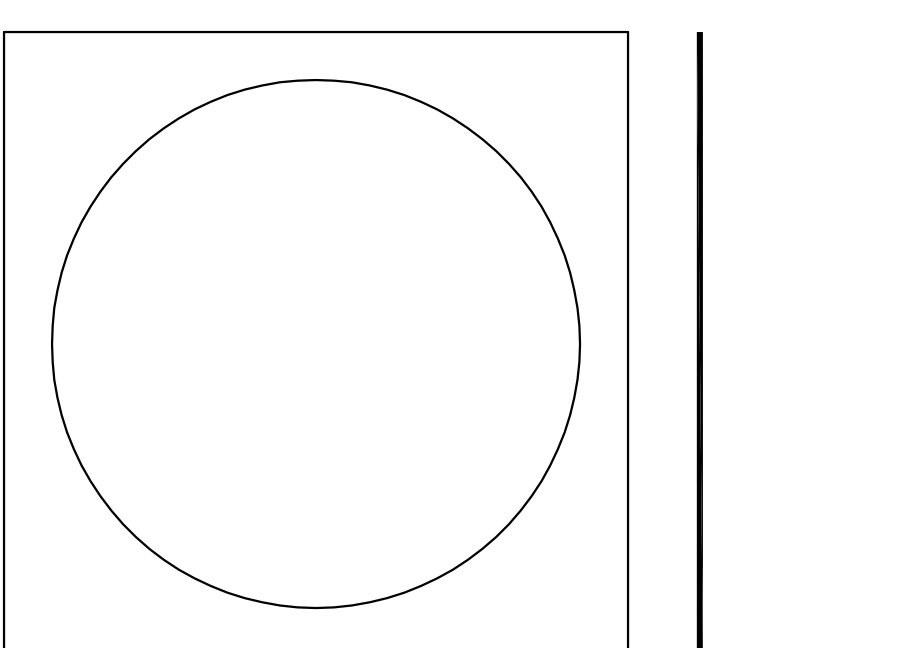

arrowstreet inc

Architects  
Interior Designers  
Planners  
Urban Designers  
212 Elm Street  
Somerville, MA 02144  
617.623.5555

Project No: 03085-02  
Drawn By: MJH  
Checked By: SS  
Issue Date: 18 FEBRUARY 2005

Revisions	No	Date	Description	By

Drawing Title:  
**INTERIOR ELEVATIONS**

Drawing Number  
**A6.01**