

INSTALLATION:

1. EXCAVATE A 6"x 6" TRENCH ALONG THE LINE OF PLACEMENT FOR THE FILTER BARRIER.
2. UNROLL A SECTION AT A TIME AND POSITION THE POSTS AGAINST THE BACK (DOWNSTREAM) WALL OF THE TRENCH.
3. DRIVE POSTS INTO THE GROUND UNTIL APPROXIMATELY 2" OF FABRIC IS LYING ON THE TRENCH BOTTOM. JOIN SECTION AS SHOWN ABOVE.
4. LAY THE TOE-IN FLAP OF FABRIC ONTO THE UNDISTURBED BOTTOM OF THE TRENCH. BACKFILL THE TRENCH AND TAMP THE SOIL. TOE-IN CAN ALSO BE ACCOMPLISHED BY LAYING THE FABRIC FLAP ON UNDISTURBED GROUND AND PILING AND TAMPING FILL AT THE BASE, BUT MUST BE ACCOMPANIED BY AN INTERCEPTION DITCH.
5. BARRIER SHALL BE MIRAFI SILT FENCE OR APPROVED EQUAL.

FILTER BARRIER
NOT TO SCALE

NOTE

LOCATION / WARNING TAPE SHALL BE INSTALLED OVER CENTERLINE OF PIPE AT A MAXIMUM OF 24 INCHES BELOW FINISH GRADE.

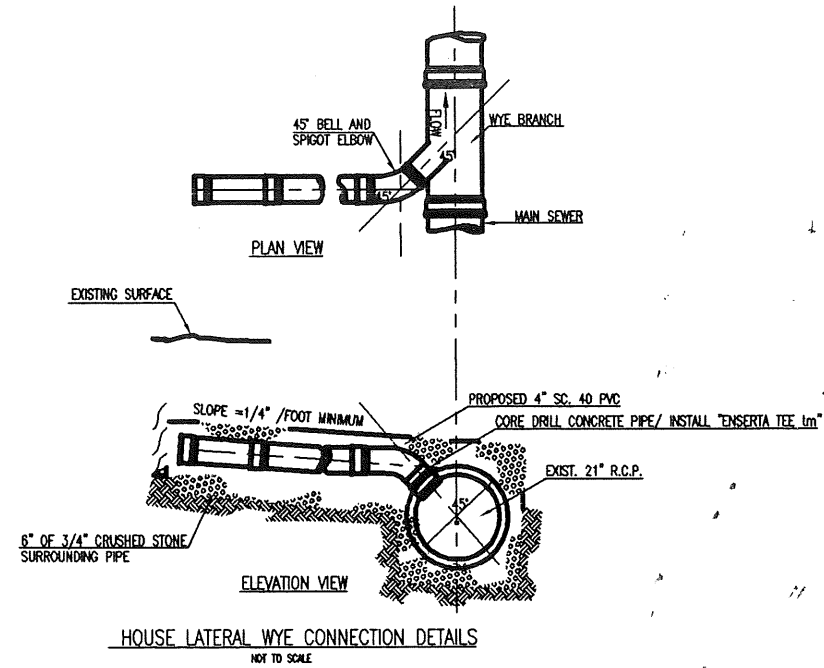

HOUSE LATERAL WYE CONNECTION DETAILS
NOT TO SCALE

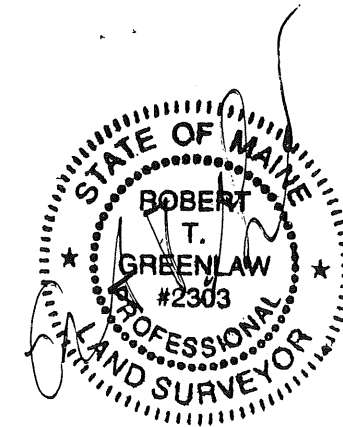

DETAIL SHEET
456 CAPISIC STREET PORTLAND, MAINE

FOR:
RYAN HINES

DRAWN BY: RTG
CHECKED BY: KCC
SCALE: 1" = 50'
DATE OF SURVEY: 06/07/2005
JOB NUMBER: 2005076
SHEET: 5 OF 6

PREPARED BY:
BACK BAY BOUNDARY, INC.
PROFESSIONAL LAND SURVEYING
643 FOREST AVENUE
PORTLAND, MAINE 04101
207-774-2855 FAX 207-347-4346