

16 DEVICE MOUNTING LOCATIONS
1/2" = 1'-0"

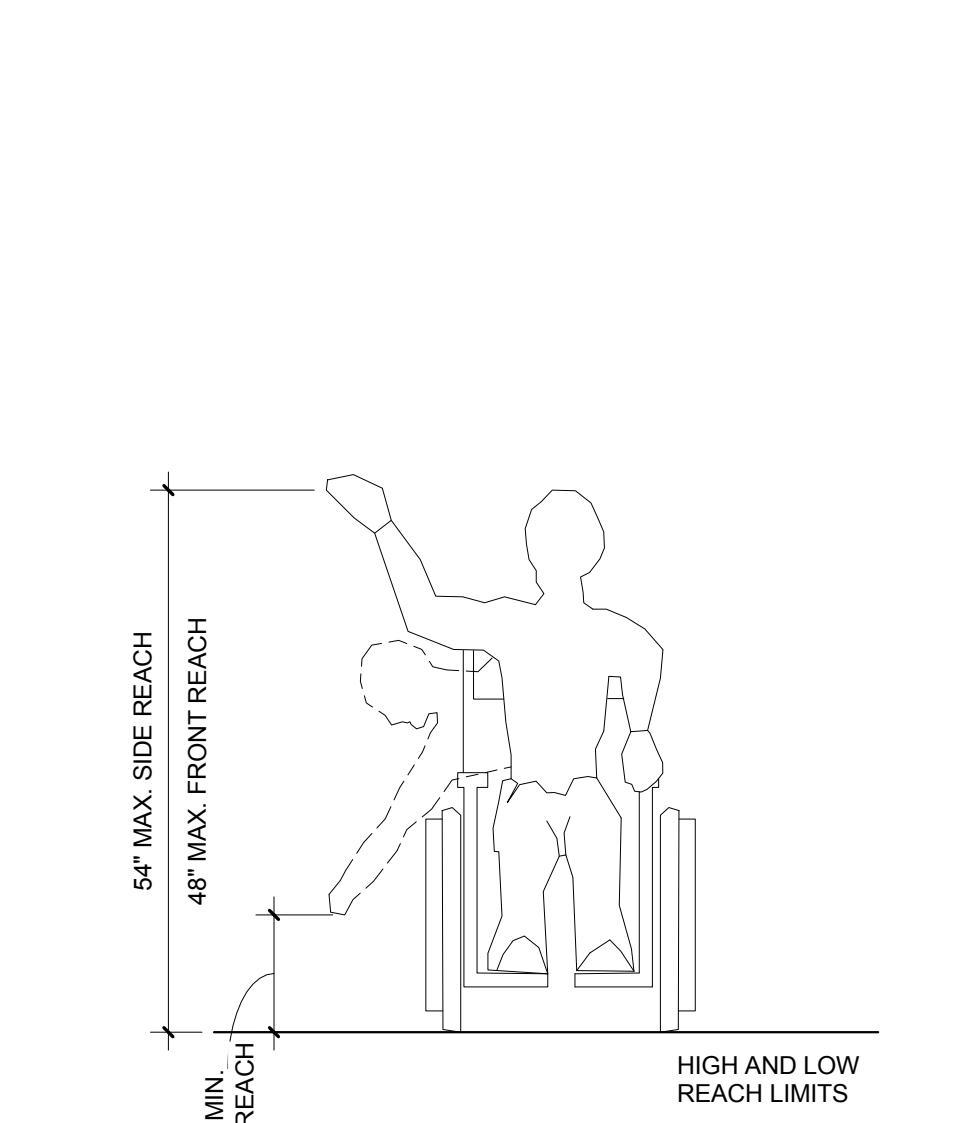

12 REACH LIMITATIONS
1/2" = 1'-0"

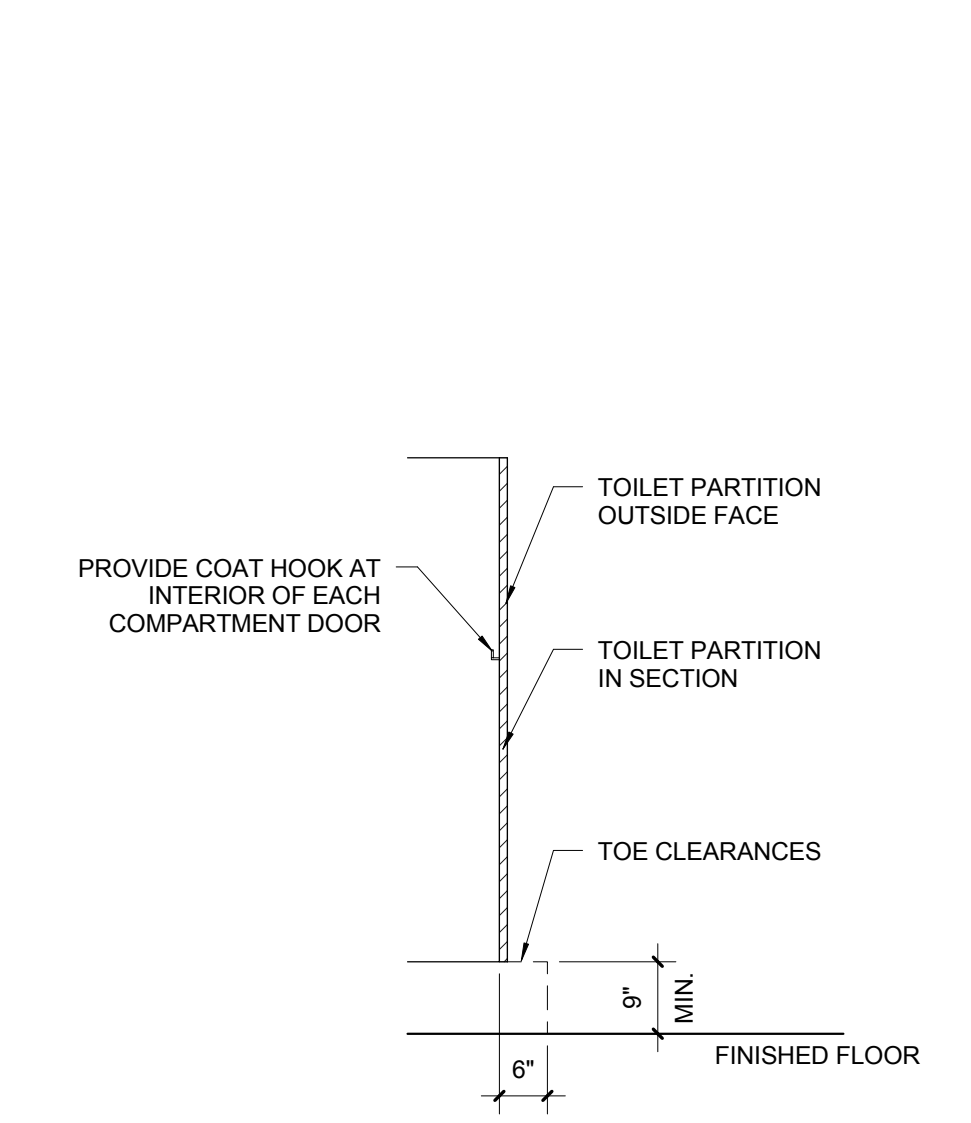

8 ACCESSIBLE PARTITION
1/2" = 1'-0"

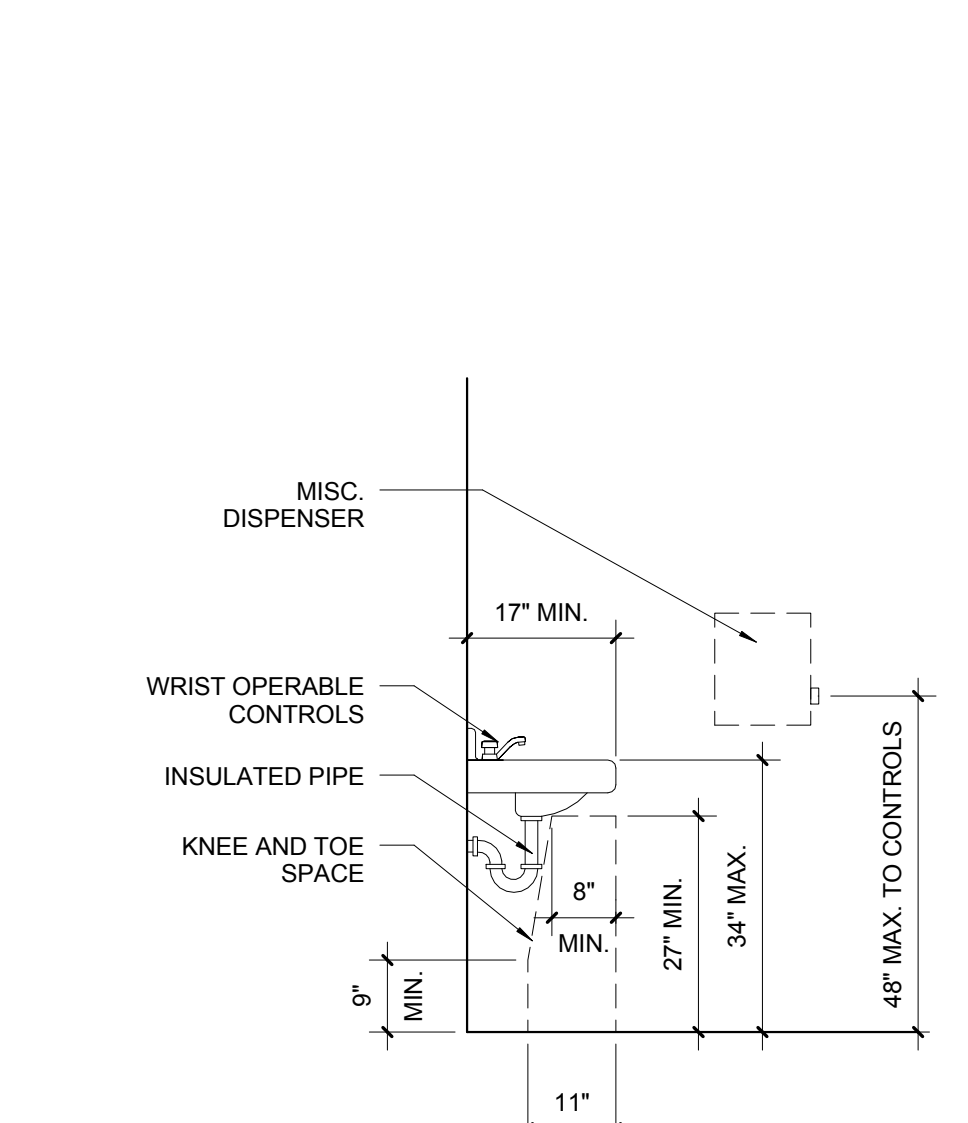

4 ACCESSIBLE LAVATORY
1/2" = 1'-0"

GENERAL NOTES

1. ALL CONSTRUCTION ACTIVITIES SHALL BE COMPLETED IN FULL COMPLIANCE WITH THE AMERICANS WITH DISABILITIES ACT (ADA) AND ARCHITECTURAL AND TRANSPORTATION BARRIERS COMPLIANCE BOARD, FEDERAL REGISTER 36CFR PARTS 1190 AND 1191, ACCESSIBILITY GUIDELINES FOR BUILDINGS AND FACILITIES; ARCHITECTURAL BARRIERS ACT (ABA) ACCESSIBILITY GUIDELINES; PROPOSED RULE, PUBLISHED IN THE FEDERAL REGISTER ON JULY 23, 2004, AS HAS BEEN ADOPTED BY METRO.
2. TOILET ACCESSORIES (RECESSED HAND DRYERS, TOILET PAPER DISPENSERS, SOAP DISPENSERS) ARE OWNER FURNISHED/ CONTRACTOR INSTALLED. CONTRACTOR INSTALL ITEMS IN COMPLIANCE WITH THE ADA ACCESSIBILITY REQUIREMENTS SHOWN IN THE DETAILS ON THIS SHEET.
3. PUBLIC WALKWAYS SHALL BE A MINIMUM OF 36" WIDE AND NOT HAVE ABRUPT CHANGES IN ELEVATION GREATER THAN 1/2 INCH. CHANGES IN LEVEL UP TO 1/4 INCH REQUIRE NO EDGE TREATMENT. CHANGES IN LEVEL FROM 1/4 INCH TO 1/2 INCH REQUIRE A BEVELED EDGE WITH SLOPE NO GREATER THAN 1:2.
4. SLOPES ON WALKWAYS SHALL NOT EXCEED 1:20. ANY WALKWAY WITH A SLOPE GREATER THAN 1:20 SHALL BE CONSIDERED A RAMP. IN NEW CONSTRUCTION, THE MAXIMUM SLOPE FOR A RAMP IS 1:12. IN EXISTING BUILDINGS, RAMP MAY HAVE A SLOPE NO GREATER THAN 1:8.
5. ALL LANDINGS SHALL BE AT LEAST AS WIDE AS THE RAMP THEY SERVE, AND 60 INCHES CLEAR IN LENGTH. WHERE LANDINGS CHANGE DIRECTION, A MINIMUM LEVEL AREA OF 60 INCHES IS REQUIRED.
6. WHERE RAMP HAVE A SLOPE GREATER THAN 1:20, PROVIDE HANDRAILS ON BOTH SIDES. WHERE THERE IS A DROP OFF OF MORE THAN 2 INCHES, PROVIDE A RAILING ON BOTH SIDES.
7. CROSS SLOPES ON RAMP SHALL NOT EXCEED 1:50.
8. UNLESS OTHERWISE NOTED, SIDEWALK SURFACES SHALL HAVE A SLIP RESISTANT, BROOM FINISH.

PROJECTS SHALL MEET ADA AND OTHER ACCESSIBILITY REQUIREMENTS AS ADOPTED BY THE SPECIFIC JURISDICTION.

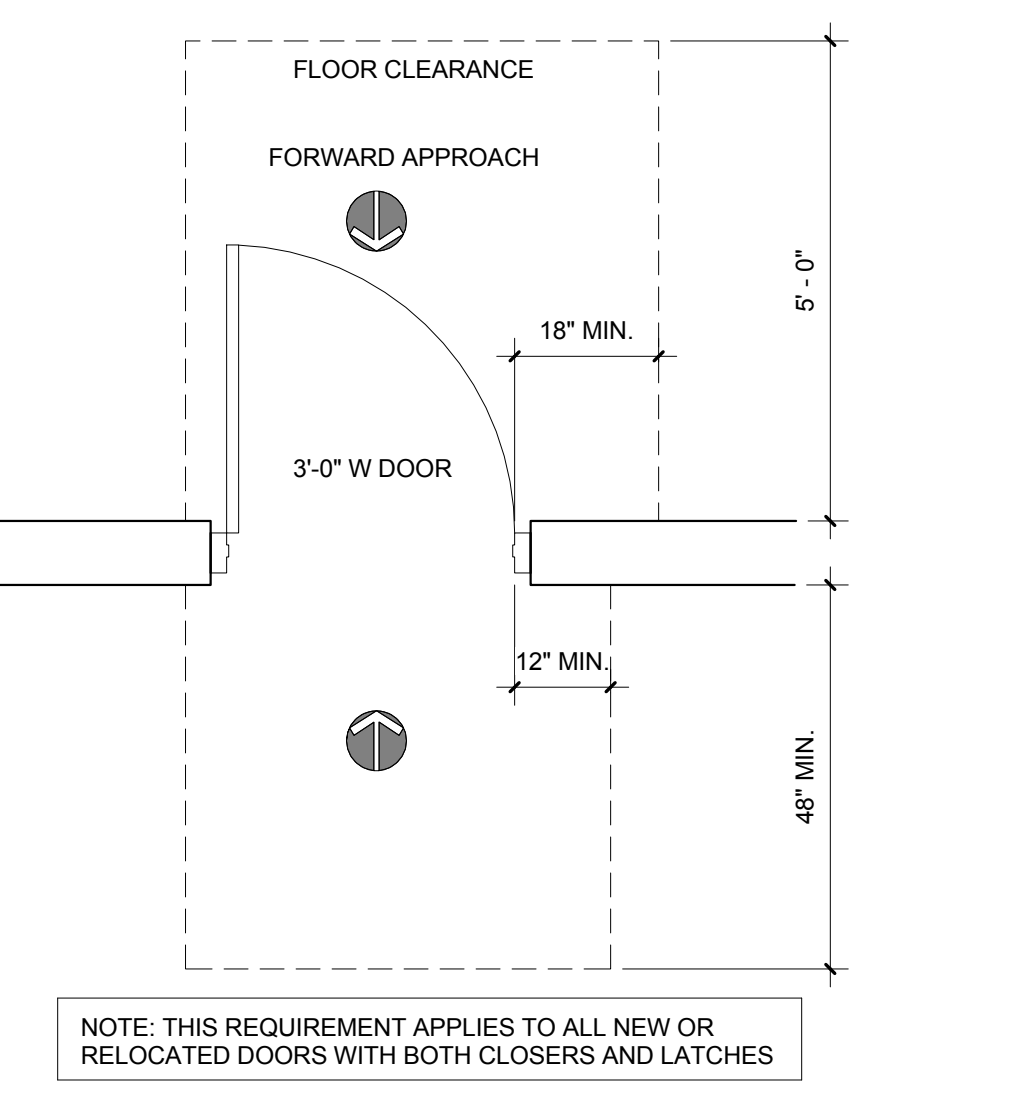

15 FLOOR CLEARANCE
1/2" = 1'-0"

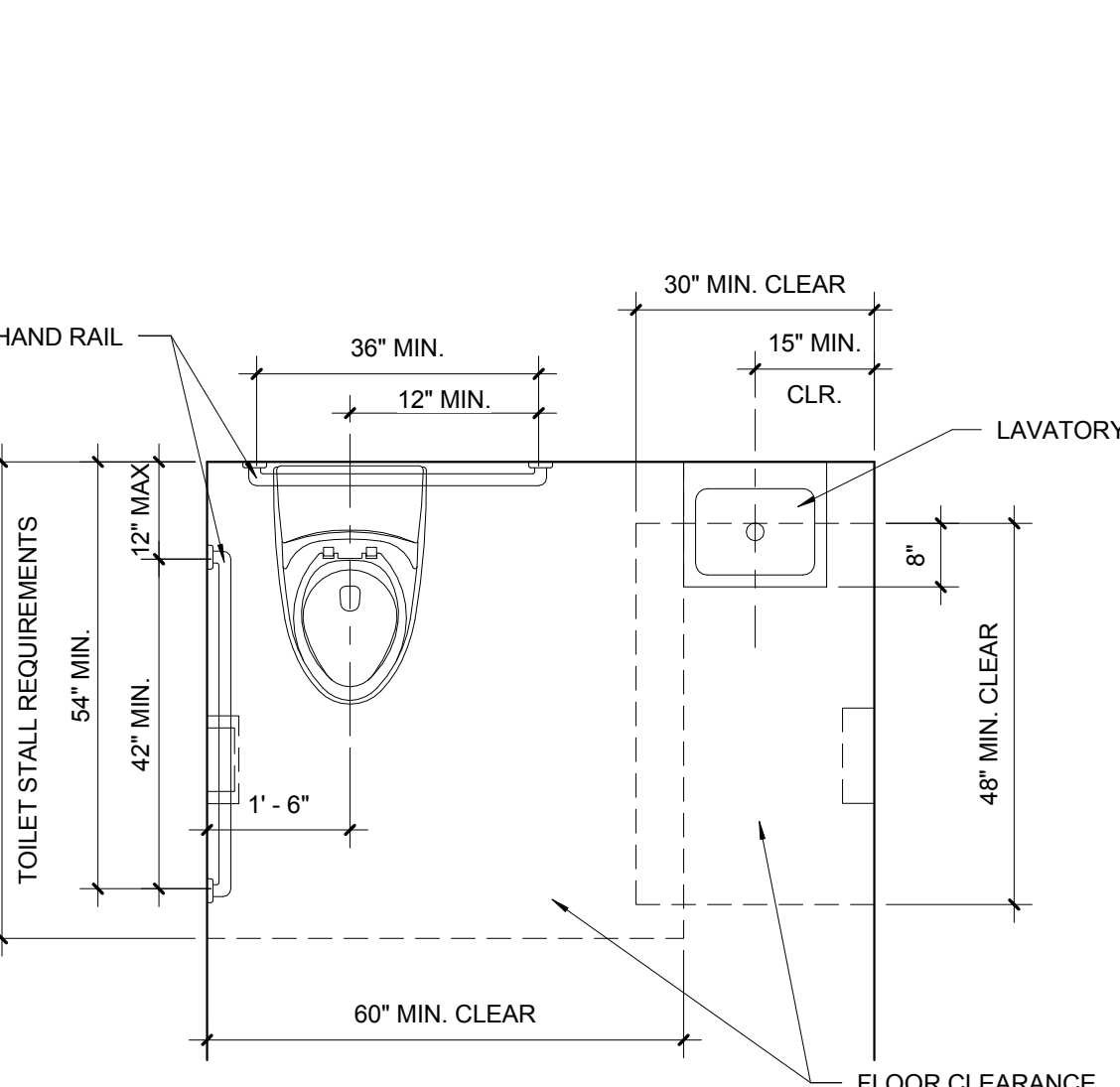

11 ACCESSIBLE TOILET ROOM
1/2" = 1'-0"

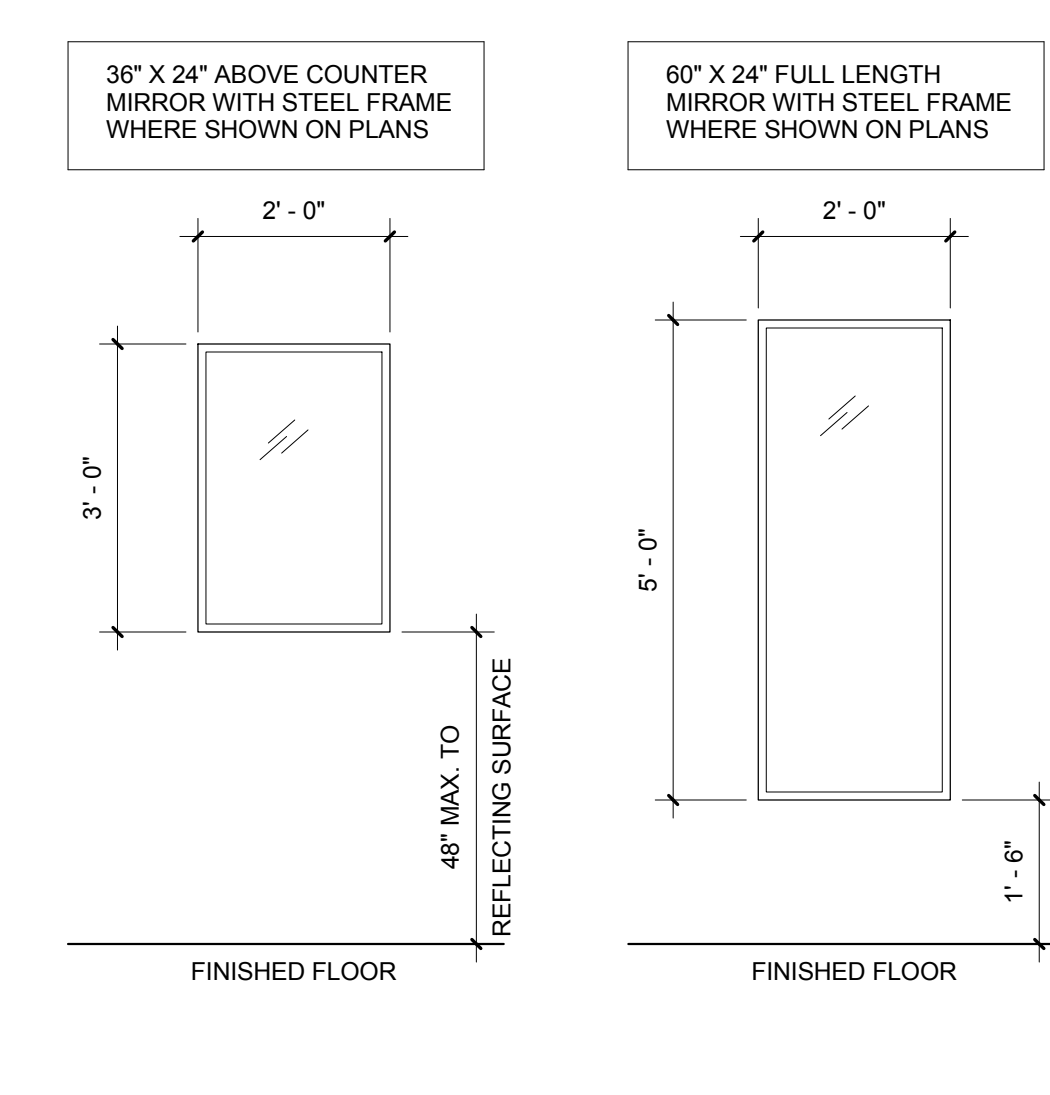

7 ACCESSIBLE MIRROR
1/2" = 1'-0"

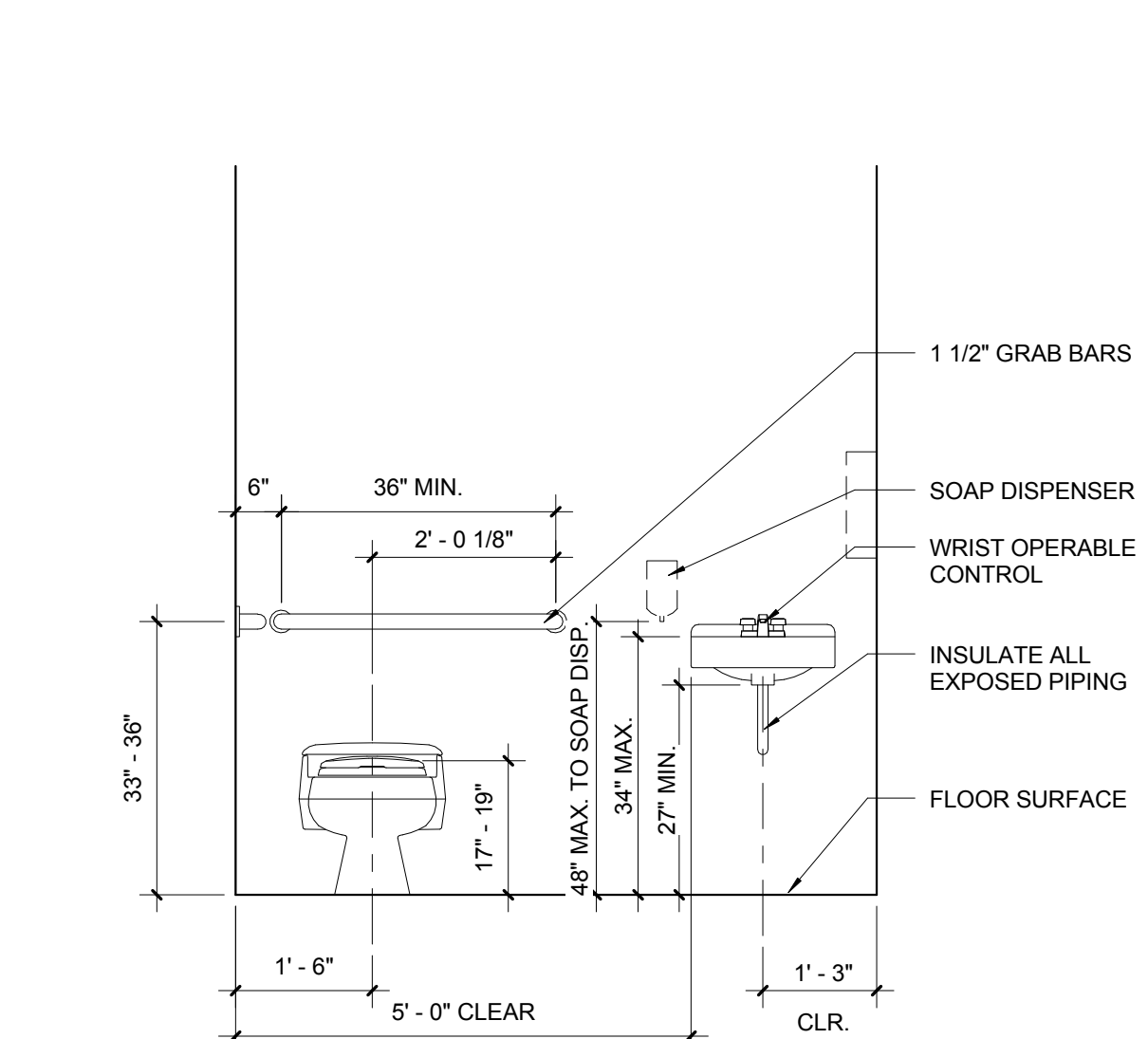

3 ACCESSIBLE TOILET
1/2" = 1'-0"

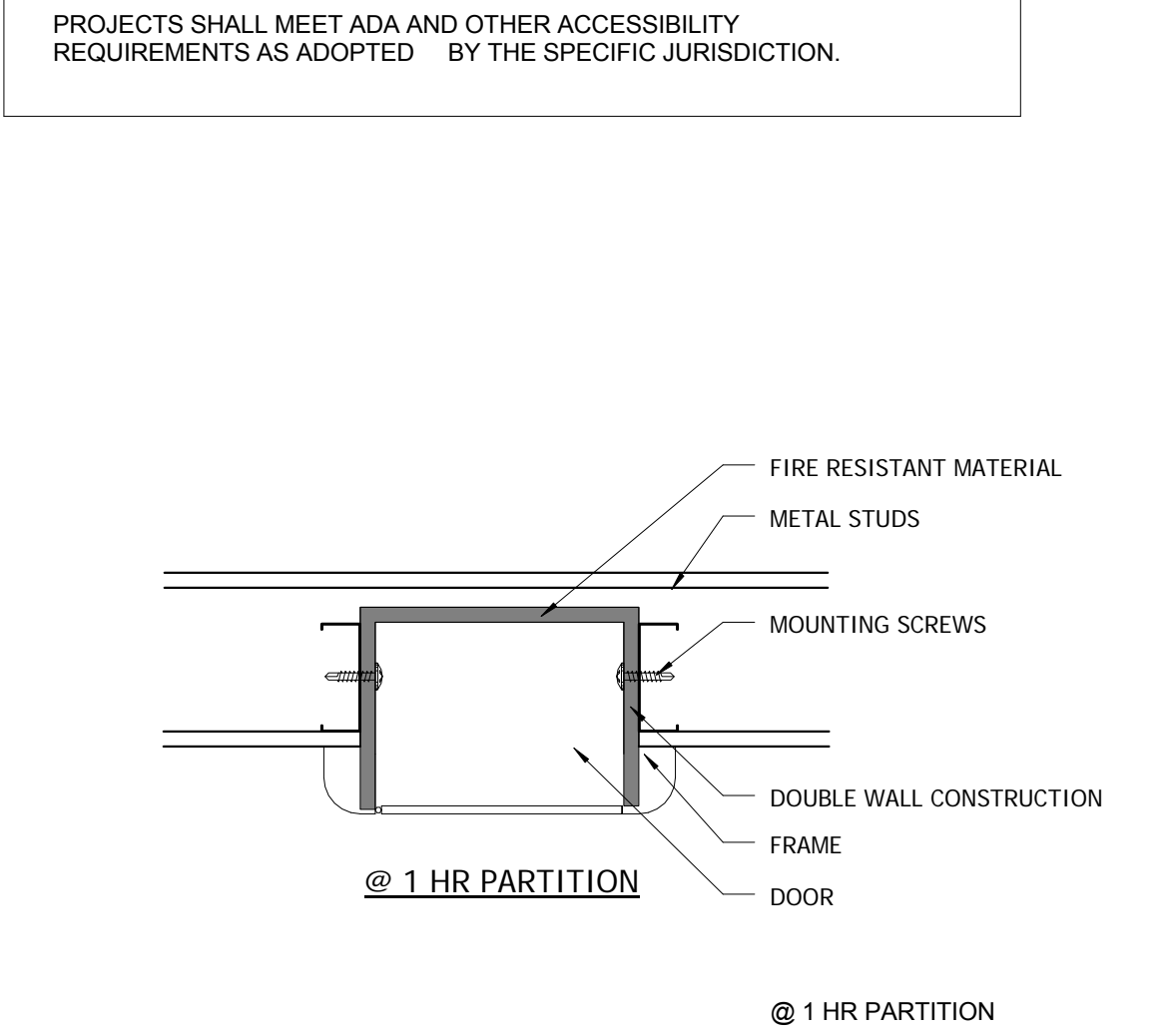

18 FIRE EXTINGUISHER CABINET
1 1/2" = 1'-0"

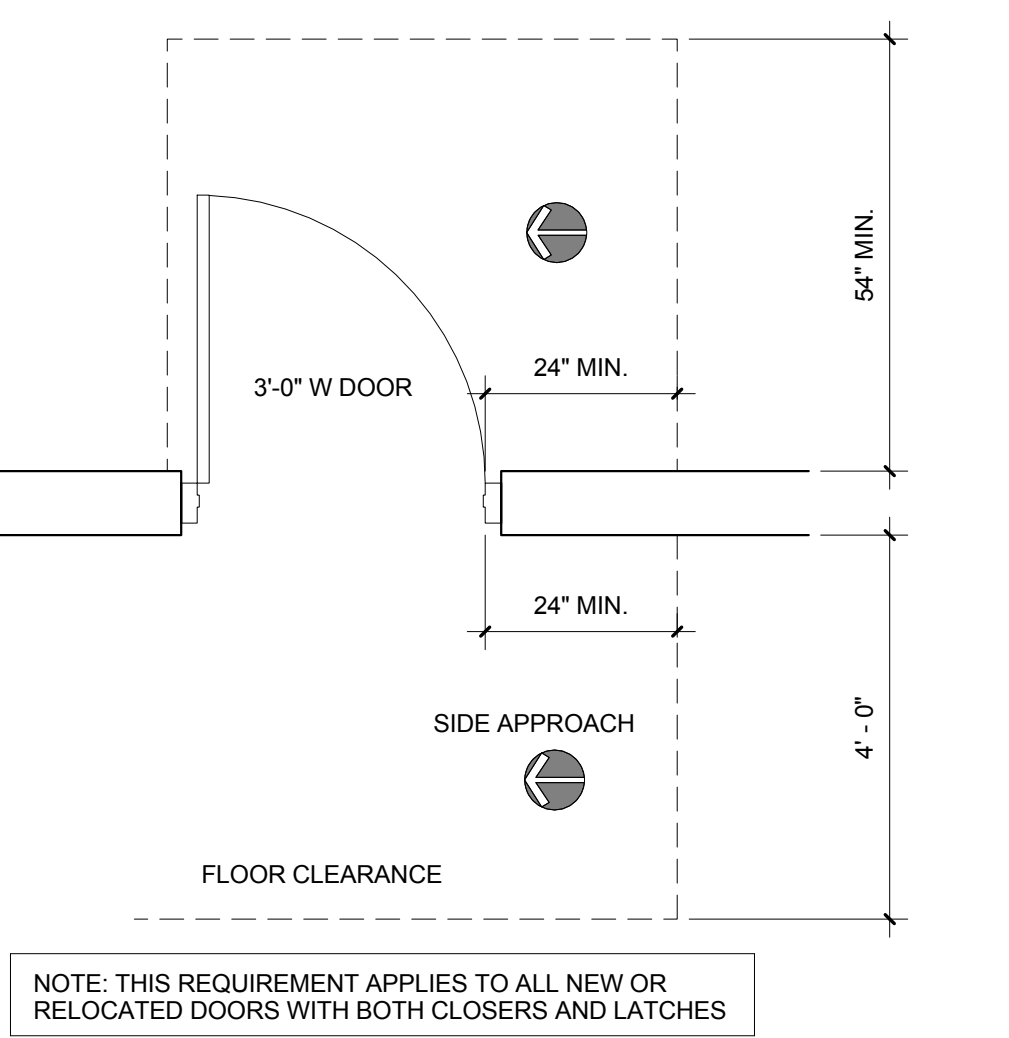

14 FLOOR CLEARANCE
1/2" = 1'-0"

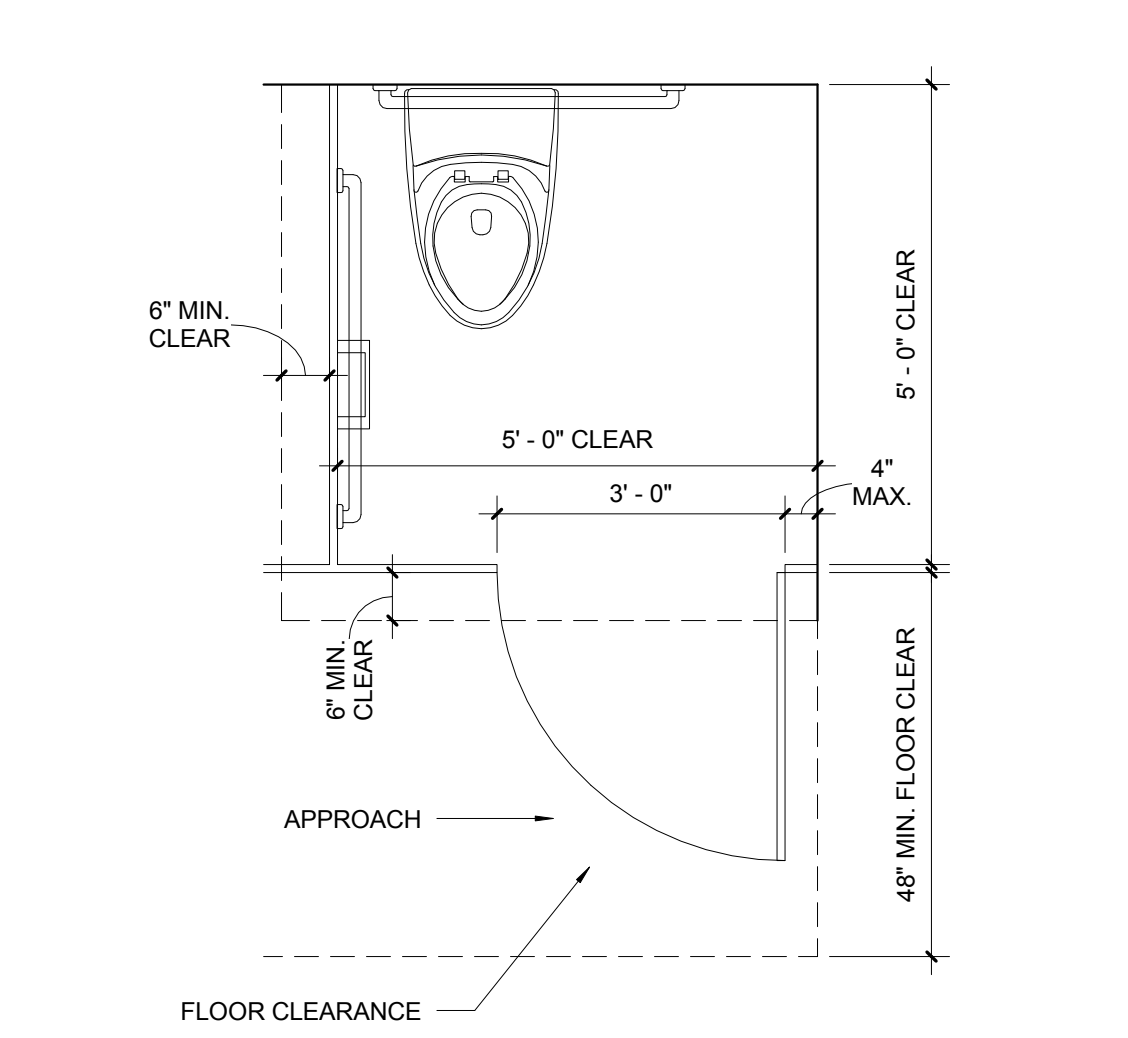

10 ACCESSIBLE TOILET STALL
1/2" = 1'-0"

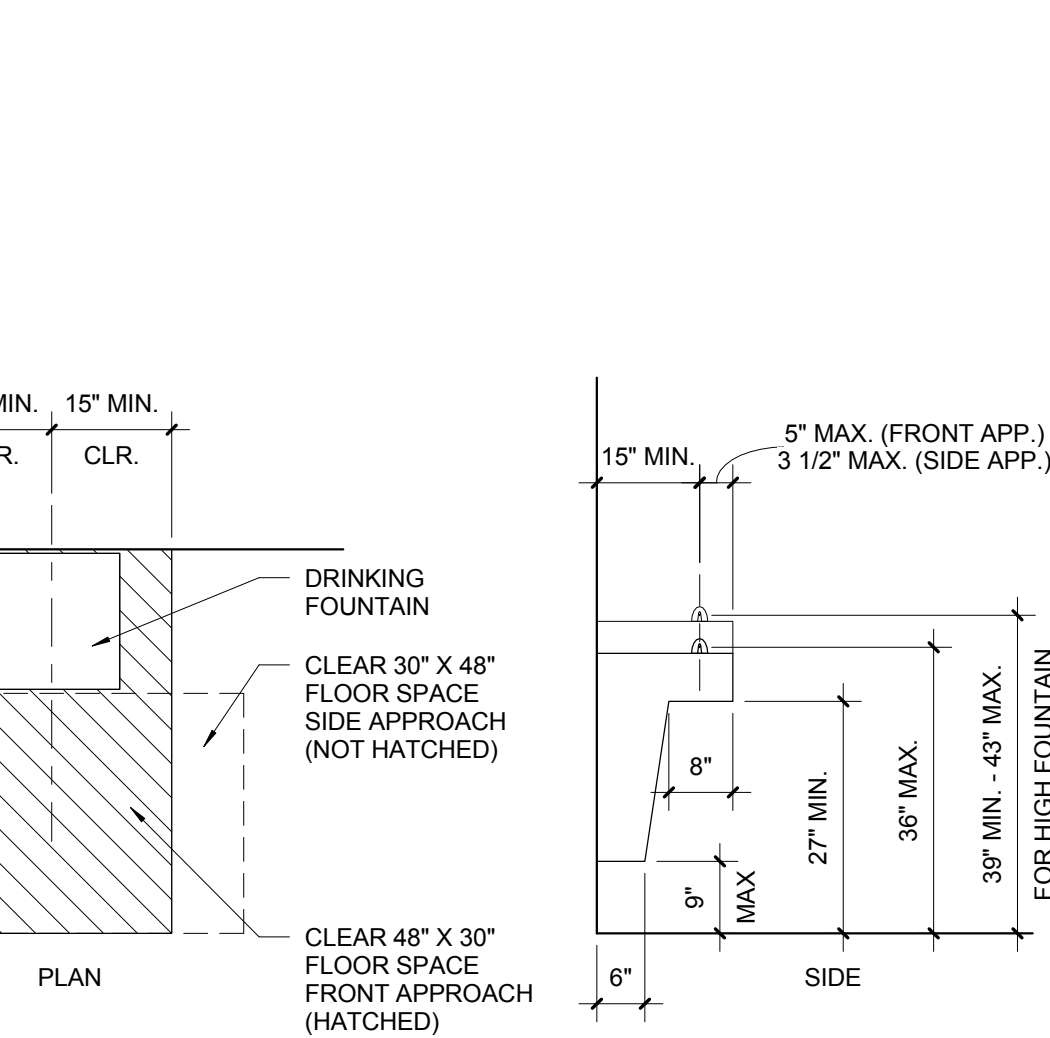

6 ACCESSIBLE DRINKING FOUNTAIN
1/2" = 1'-0"

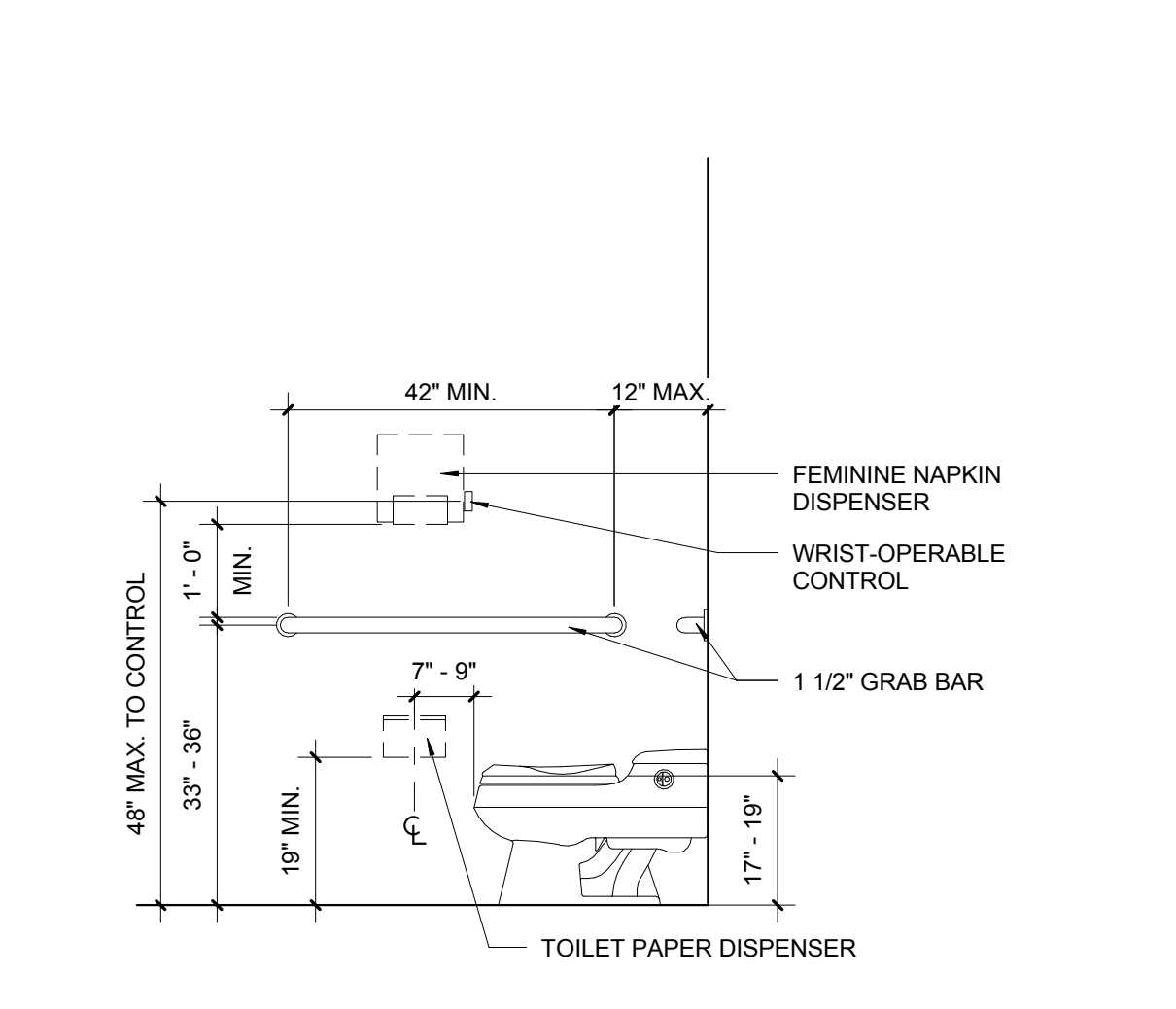

2 ACCESSIBLE TOILET
1/2" = 1'-0"

- SIGNAGE NOTES:**
1. TACTILE GRAPHICS ARE REQ'D AT ALL PERMANENT ROOMS & SPACES.
 2. TACTILE GRAPHICS MUST BE ACCOMPANIED W/ GRADE 2 BRAILLE.
 3. WHEN BRAILLE SIGNAGE IS USED, IT SHALL BE MOUNTED BETWEEN 48"-60" MEASURED TO THE BOTTOM OF THE BRAILLE.
 4. ROOM SIGNAGE MUST BE MOUNTED ON LATCH SIDE OF THE DOOR.
 5. WHERE PICTOGRAMS ARE PROVIDED, THEY SHALL HAVE TACTILE TEXT DESCRIPTIONS.

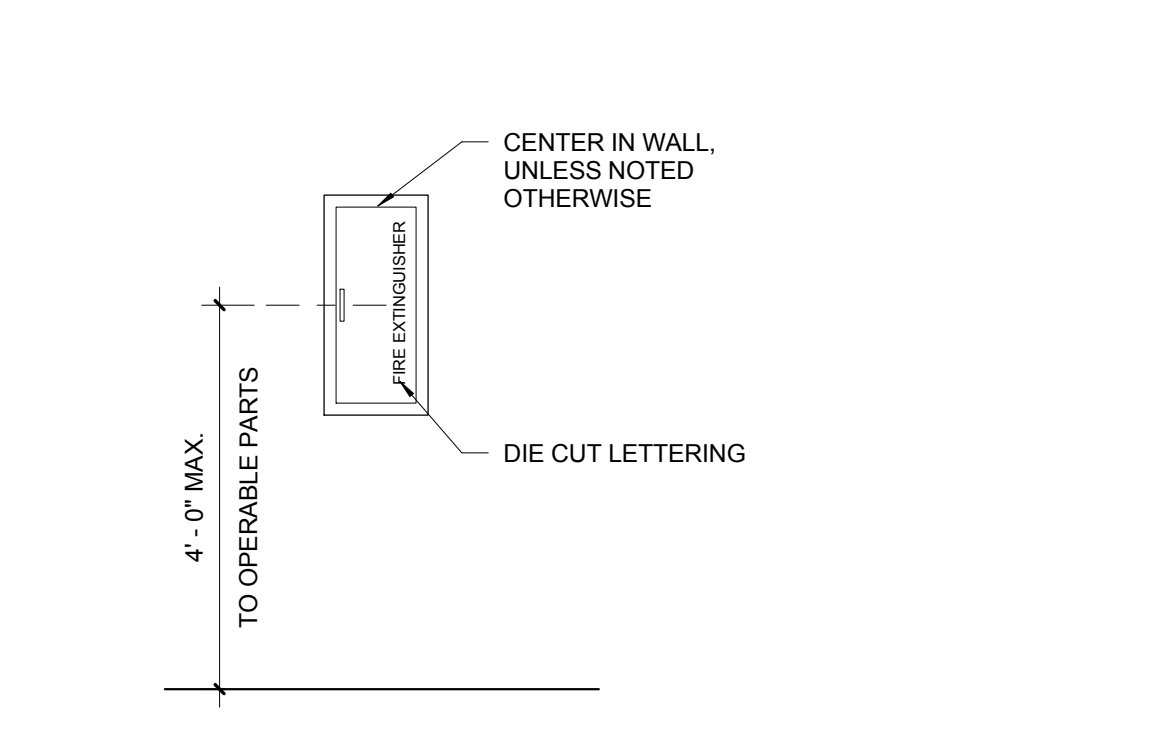

17 FIRE EXTINGUISHER CABINET
1/2" = 1'-0"

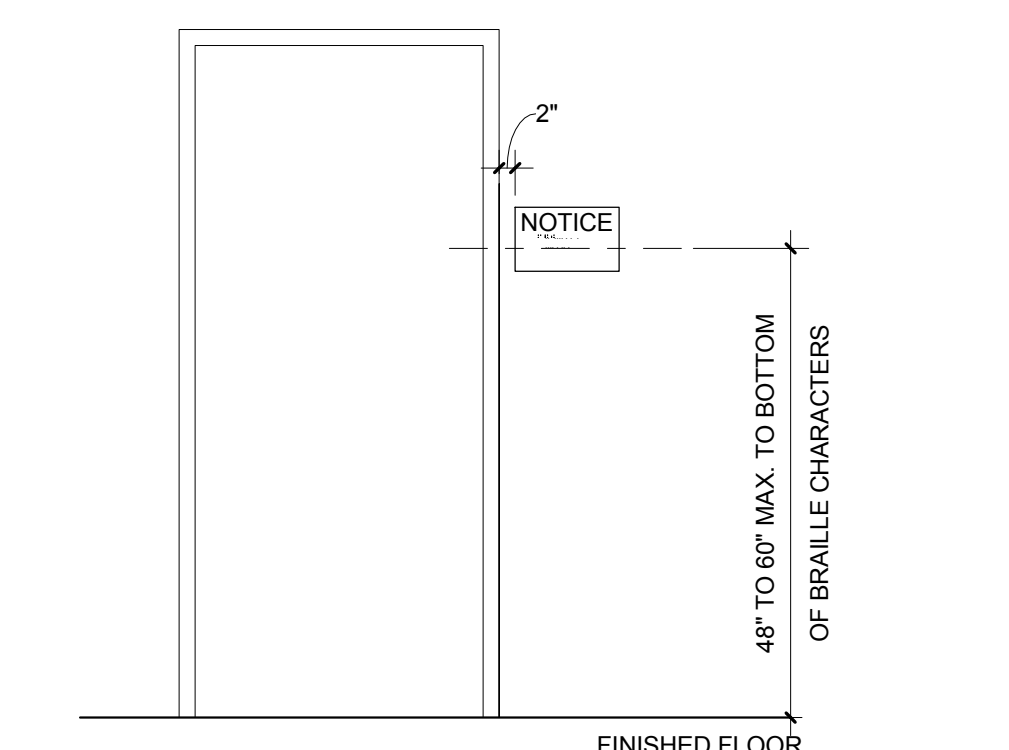

13 ACCESSIBLE SIGNAGE
1/2" = 1'-0"

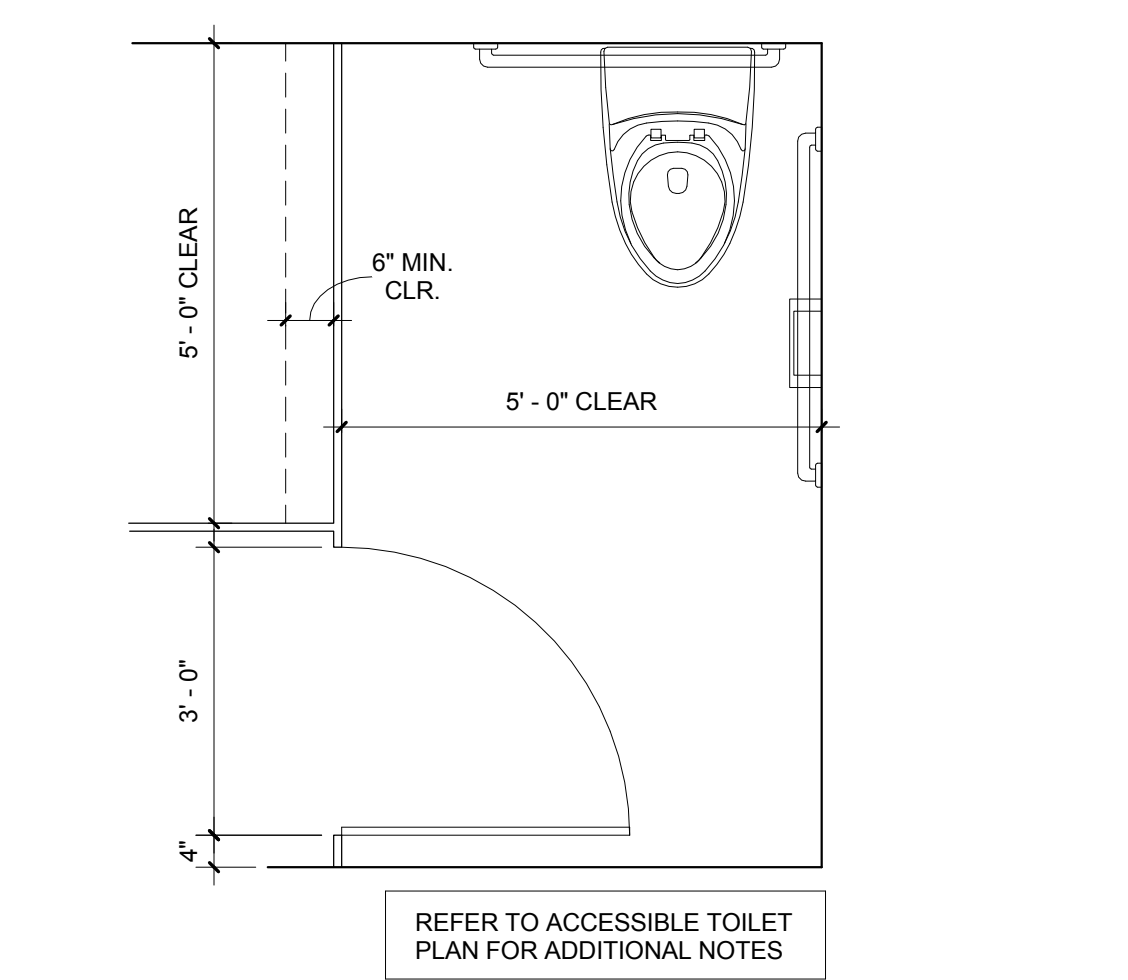

9 ACCESSIBLE TOILET STALL
1/2" = 1'-0"

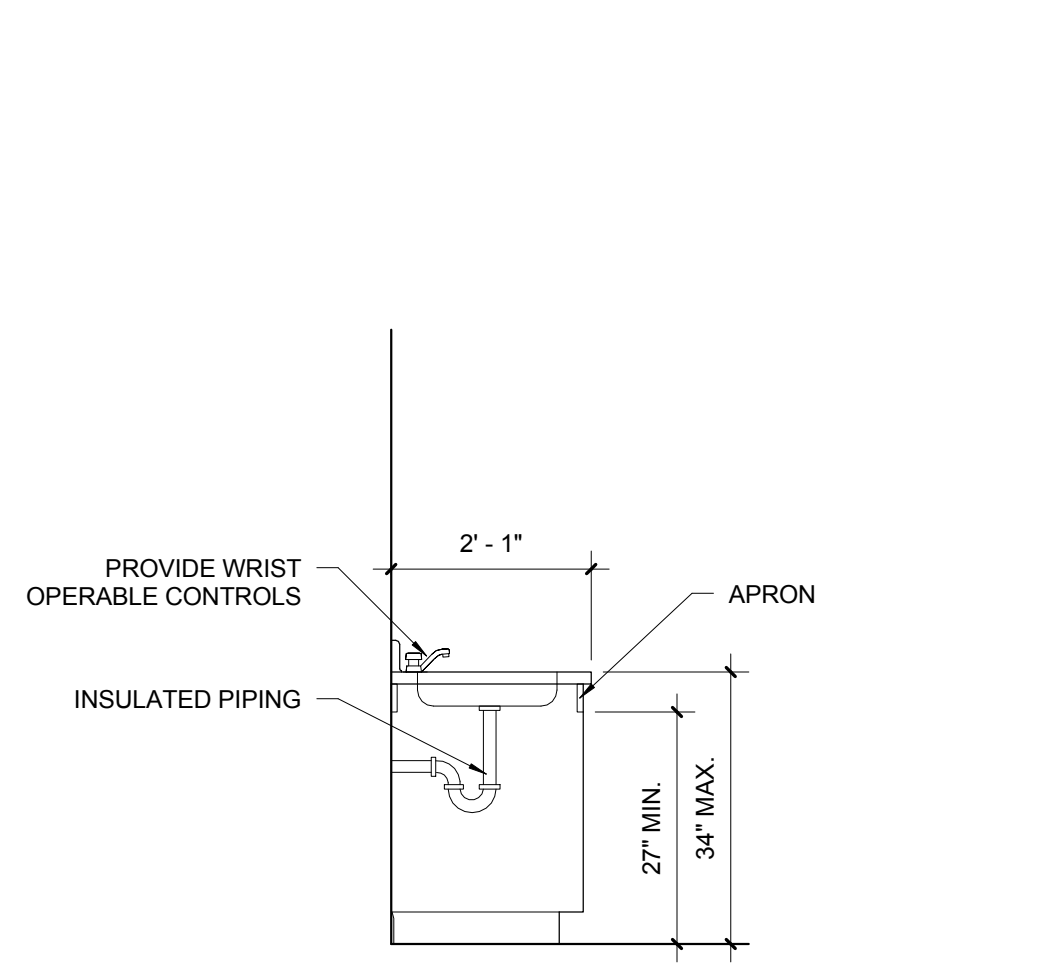

5 ACCESSIBLE SINK
1/2" = 1'-0"

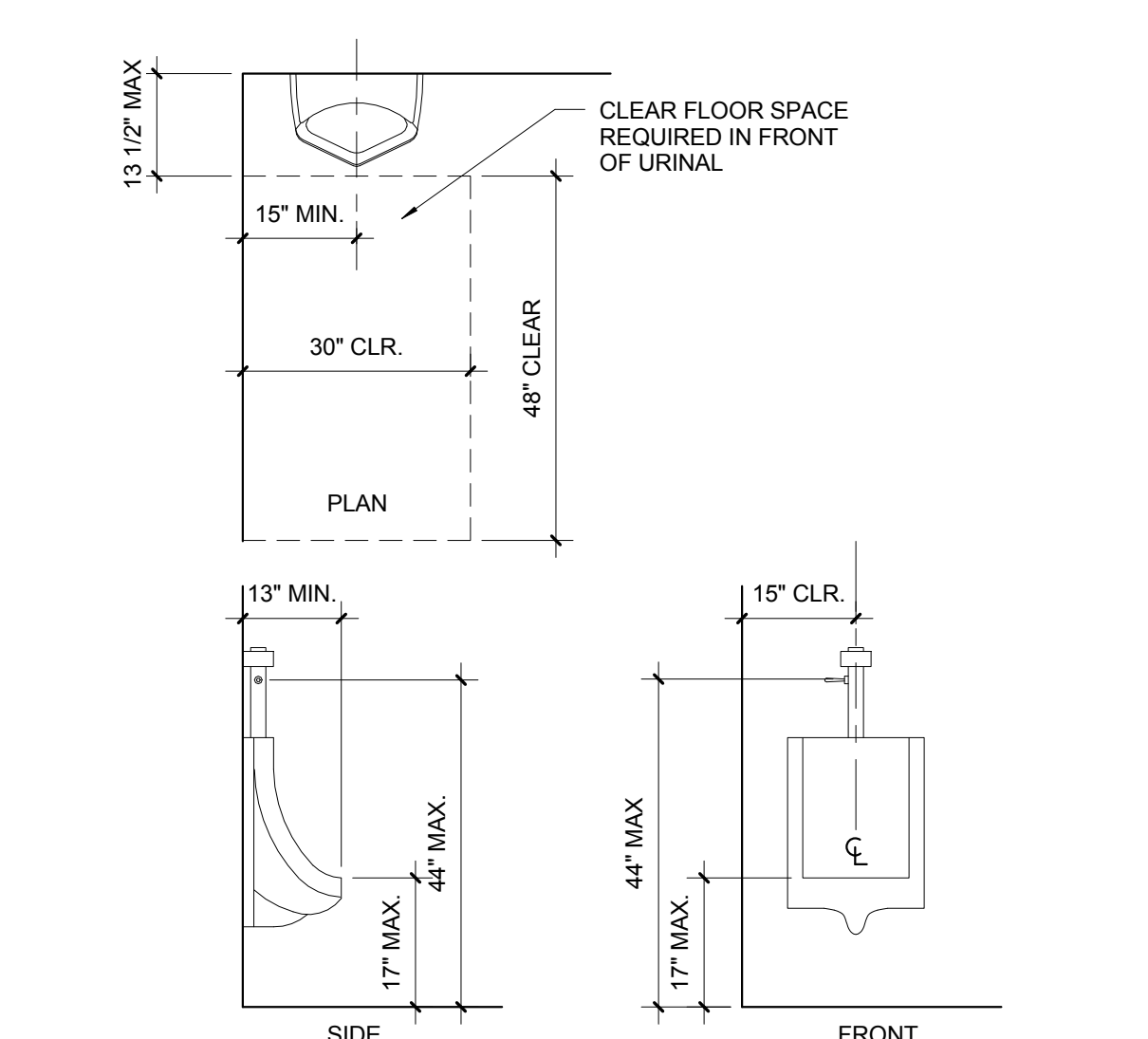

1 ACCESSIBLE URINAL
1/2" = 1'-0"