

# INSTALLATION AND OPERATION MANUAL

## HE1XIN



HE1XINH



HE1XINV

**NOTE: Disconnect Switch and 24V Transformer Standard**

### ⚠ WARNING

**RISK OF FIRE, ELECTRIC SHOCK, OR INJURY. OBSERVE ALL CODES AND THE FOLLOWING:**

1. Before servicing or cleaning the unit, switch power off at disconnect switch or service panel and lock-out/tag-out to prevent power from being switched on accidentally. More than one disconnect switch may be required to de-energize the equipment for servicing.
2. This installation manual shows the suggested installation method. Additional measures may be required by local codes and standards.
3. Installation work and electrical wiring must be done by qualified professional(s) in accordance with all applicable codes, standards and licensing requirements.
4. Any structural alterations necessary for installation must comply with all applicable building, health, and safety code requirements.
5. This unit must be grounded.
6. Sufficient air is needed for proper combustion and exhausting of gases through the flue (chimney) of fuel burning equipment that might be installed in the area affected by this equipment. If this unit is exhausting air from a space in which chimney-vented fuel burning equipment is located, take steps to assure that combustion air supply is not affected. Follow the heating equipment manufacturer's requirements and the combustion air supply requirements of applicable codes and standards.
7. Use the unit only in the manner intended by the manufacturer. If you have questions, contact the manufacturer.
8. This unit is intended for general ventilating only. Do not use to exhaust hazardous or explosive materials and vapors. Do not connect this unit to range hoods, fume hoods or collection systems for toxics.
9. When cutting or drilling into wall or ceiling, do not damage electrical wiring and other hidden utilities.
10. If installed indoors this unit must be properly ducted to the outdoors.

### CAUTION

To avoid motor bearing damage and noisy and/or unbalanced impellers, keep drywall spray, construction dust, etc., out of unit.



## Placement of the HE1XIN

The HE1X is designed for installation indoors.

Select a location that is central to the inside duct runs, and close to both the exhaust duct (to the outside) and the fresh air duct (from the outside). The unit can be installed in any orientation but the contractor is responsible for safe installation of the unit.

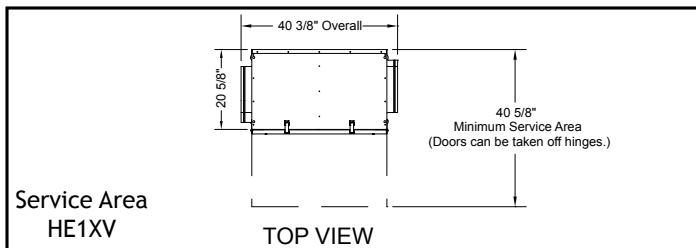
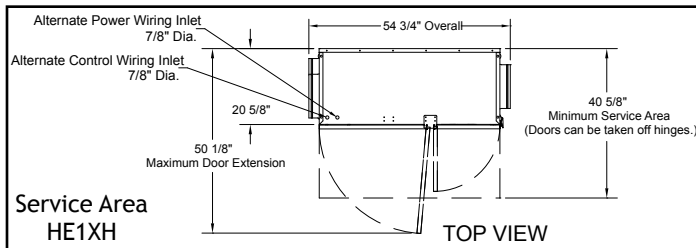

## Ducts to the Outside

The exhaust outlet and fresh air inlet on the outside of the building should be at least ten feet apart to avoid cross-contamination. The exhaust outlet should not dump air into an enclosed space or any other structure. The inlets and outlets should be screened against insects and vermin and shielded from the weather to prevent the entry of rain or snow.

**NOTE:** To prevent the entry of rain through the outside air inlet duct, observe the following:

1. velocity at face of inlet hood should not exceed 500 feet per minute (fpm).
2. inlet duct must be at least 12" inside diameter.
3. centerline length along duct from weather hood to unit inlet must be at least 48".
4. inlet duct must pitch downward to the outside; centerline of inlet hood must be at least 18" below the centerline of the unit inlet.
5. outlet duct must pitch downward to the outside with a slope of at least 1/4" to the foot.

*Ducts connecting the HE1X to the outside must be insulated, with sealed vapor barrier on both inside and outside of the insulation. Insulate both the Outside Air (OA) and Exhaust Air (EA) ducts.*

## ⚠ WARNING

The fresh air inlet should be at least 10' away from chimneys, furnace and water heater exhausts, and other sources of carbon monoxide, humidity or other contamination. Do not locate the fresh air inlet where vehicles may be serviced or left idling. Never locate the fresh air inlet inside a structure.

## Mounting the HE1XIN

The HE1X is manufactured with four screw-adjustable legs for installation at floor level in an upright position. Adequate clearance for the filter access door latches must be provided.

The HE1X may also be hung on the wall or suspended from a ceiling. Screw or bolt mounting straps or brackets directly to the sheet metal case as necessary. Remove the access doors before installing screws – make sure your fasteners don't damage internal parts. Do not screw into the access doors.

Note that leveling legs supplied with HE1X can be removed and replaced with 3/8-16 bolts to secure unit to mounting brackets, if desired.

## ⚠ WARNING

**Secure the HE1X with straps or clamps so that it cannot fall or tip in the event of accident, structural failure or earthquake.**

## CAUTION

The HE1X weighs 210 lbs. It is the installer's responsibility to make sure that the screws or bolts used for securing the units are properly selected for the loads and substrates involved.

## Inside Ductwork System

### Follow Engineer's Ductwork Design

Ductwork should be designed by an engineer to allow the unit to provide the required airflow.

If the inside ducts run through un-conditioned spaces they must be insulated with a sealed vapor barrier on both inside and outside of insulation.

### Use Dampers to Set and Balance Air

In most applications, the airflow rate for both the Fresh Air and the Exhaust Air should be roughly equal (or "balanced") for best performance of the HE1X Unit. See unit specification sheet for CFM/ESP curves.

## CAUTION

Standard HE1XIN is not suitable for speed control by rheostats. Speed control devices will damage the blowers. Balance air flows using dampers.

## Electrical Specifications

Use conduit, strain reliefs, etc. as required by code to secure the field wiring. Electrical knockouts are provided for alternate line voltage and voltage control locations for field wiring to the internal electrical box. If the alternate sites are desired for field wiring then carefully remove the knockout plugs and foam insulating plugs from the alternate sites and install them in the open knockout locations.

See drawing below for examples of some common installation approaches:

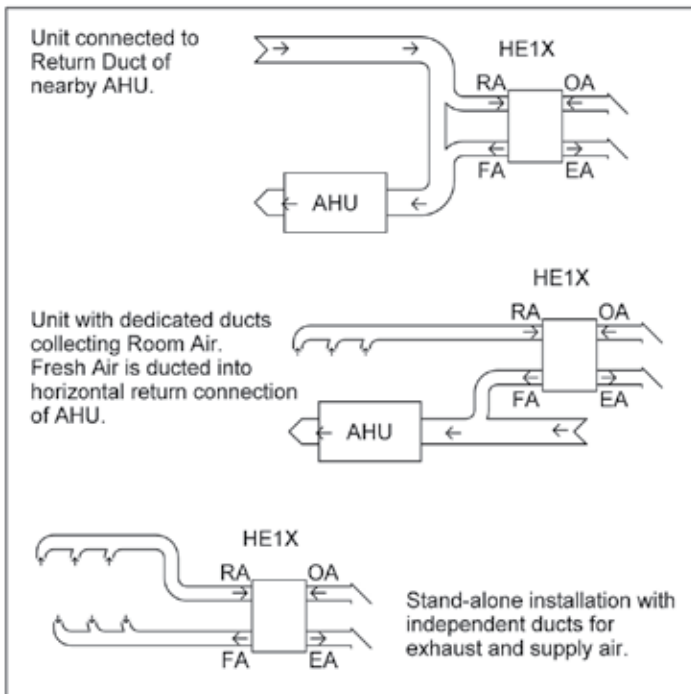

## Sound Attenuation

### General Practices

Take these simple steps to attenuate noise from the unit.

#### Outside the building:

Exhaust velocity noise is the primary cause of unit-related noise outside the building. Size the exhaust duct and grille for less than 1000 fpm air velocity. When practical, orient the exhaust air hood to point away from houses or public areas.

#### Ducts:

Make sure the ductwork at the unit outlets is stiff enough to resist the flexure and resulting booming associated with system start-up and shut-off, as well as the turbulent flow conditions at the blower outlets.

In general, provide smooth transitions from the ERV's outlets to the duct. The ducts connecting to the outlets should be straight for a sufficient distance, with gradual transitions to the final duct size.

These guidelines are consistent with SMACNA recommended duct layout practices for efficient and quiet air movement. Follow SMACNA guidelines.

#### Radiated Noise

The HE1XIN is insulated with high-density fiberglass. This provides significant attenuation of radiated sound.

The outlet ducts can be significant sources of radiated sound as well. The FA and EA ducts (outlet ducts) should be insulated for sound control. This insulation should start at the unit. At a minimum the first ten feet of duct should be insulated. All parts of the FA and EA ducts located in the mechanical space should be insulated for sound control, both to minimize sound radiation out of these ducts and also to control sound radiation into the ducts.

#### Aerodynamic (Velocity) Noise

When sound attenuation is a design concern, the primary consideration is velocity noise at the unit's Fresh Air blower outlet. The average velocity at the blower outlets is 1235 FPM when the unit is operating at 970 CFM.

## Airflow Performance

### HE1X V&H Performance

| Airflow CFM | ESP in. H2O | Watts-1P | Watts-3P | Temp EFF% | Total EFF% Winter/Summer* |
|-------------|-------------|----------|----------|-----------|---------------------------|
| 480         | 1.50        | 825      | 509      | 76        | 69/60                     |
| 560         | 1.35        | 875      | 597      | 73        | 66/58                     |
| 635         | 1.25        | 950      | 691      | 71        | 64/55                     |
| 750         | 0.90        | 1090     | 856      | 69        | 62/52                     |
| 795         | 0.75        | 1160     | 928      | 69        | 61/51                     |
| 860         | 0.50        | 1270     | 1039     | 67        | 59/49                     |
| 925         | 0.25        | 1375     | 1158     | 66        | 58/46                     |
| 970         | 0.00        | 1490     | 1246     | 65        | 57/45                     |

\*At AHRI 1060 Standard Conditions

# HE1XIN Dimensions

## HE1XINH Dimensions

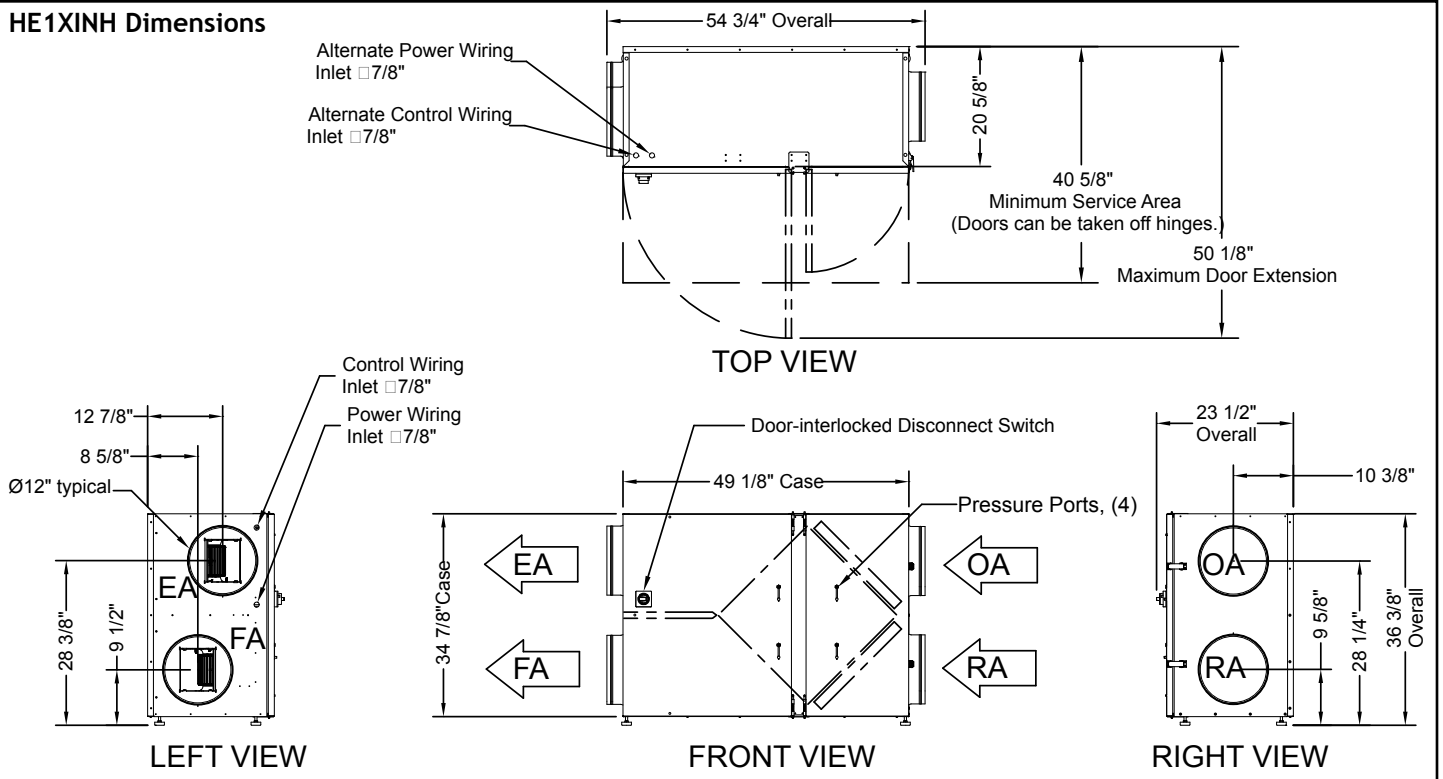

## HE1XINV Dimensions

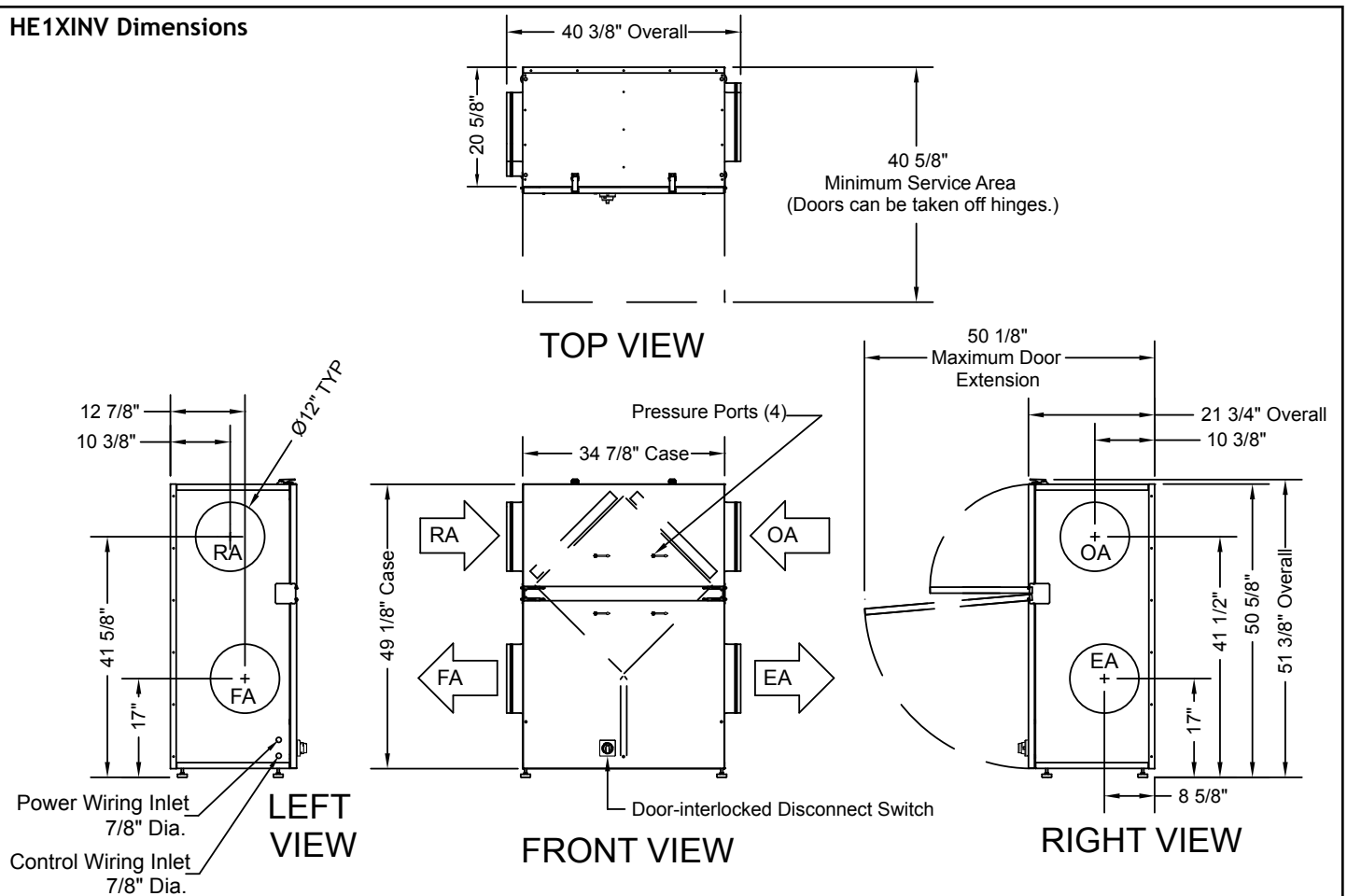

Electrical Options are identified on the Unit Label (located near electrical box). Find the complete Unit Model Number in the lower left corner of the Unit Label. Use the key below to determine motor power and voltage installed in your HE1X:

# HE1XIN Product Configuration Chart

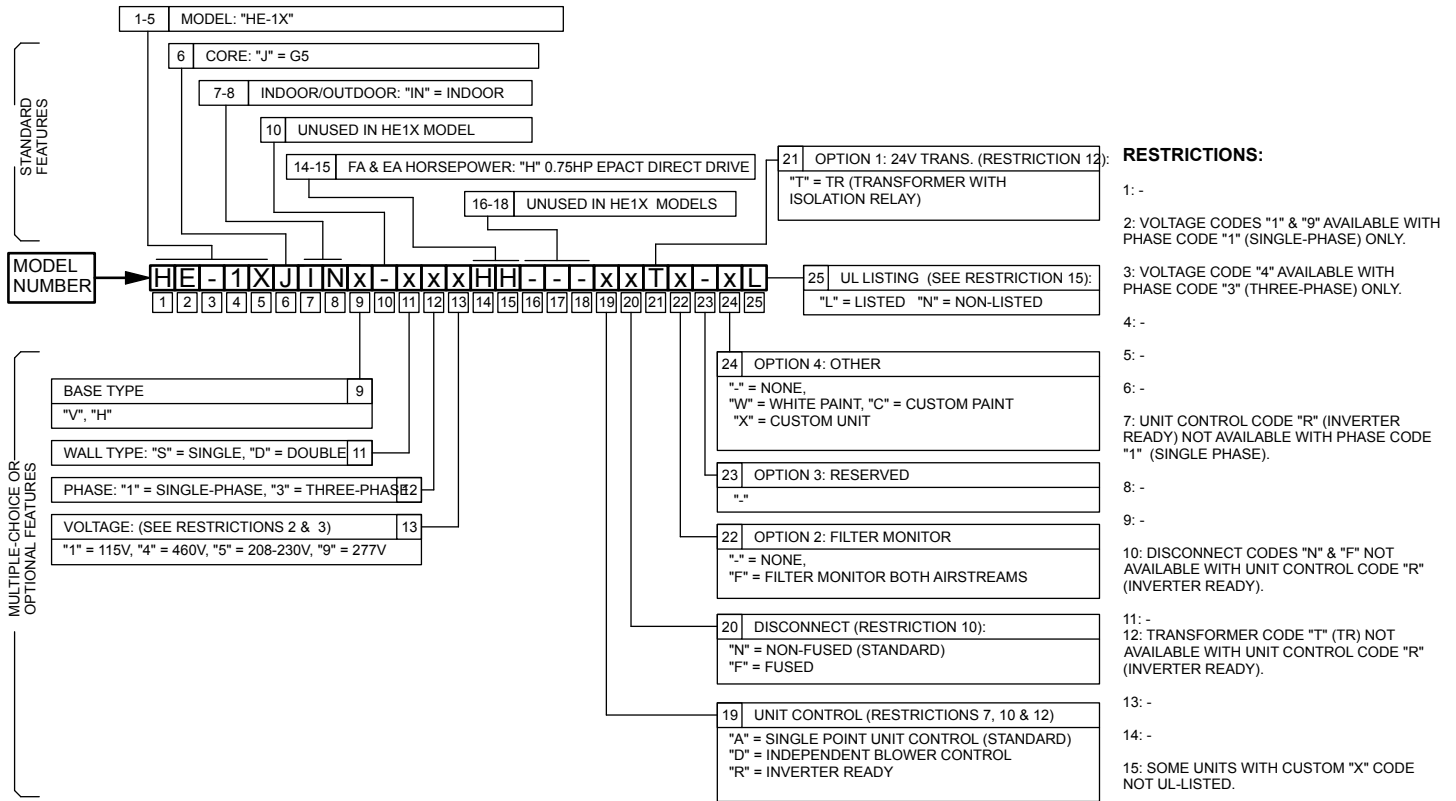

# Wiring Schematics

## HE1XIN P1

## SINGLE PHASE UNIT - STANDARD

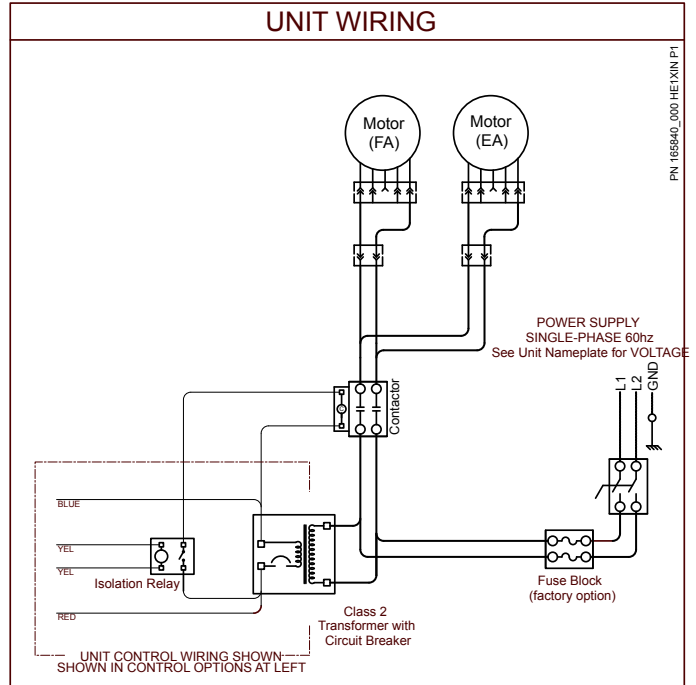
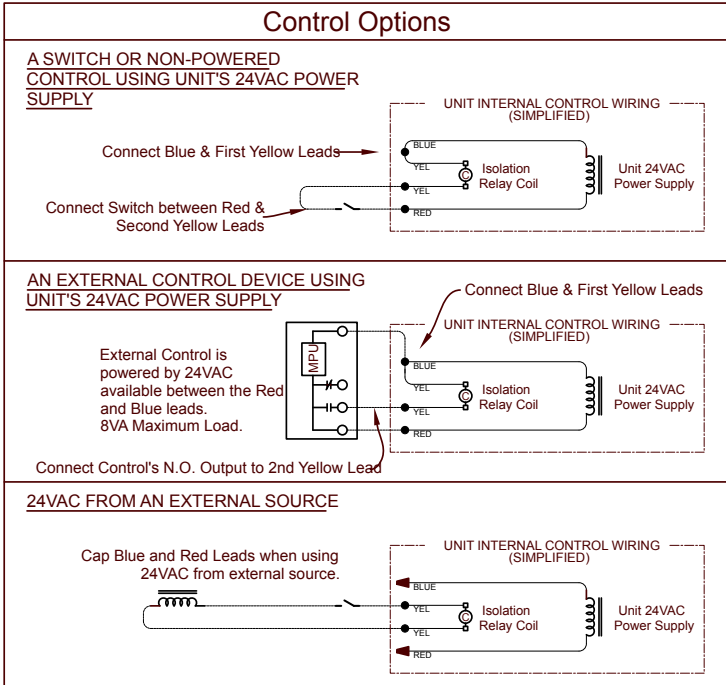

## HE1XIN P1 IBC

## SINGLE PHASE UNIT WITH INDEPENDENT BLOWER CONTROL

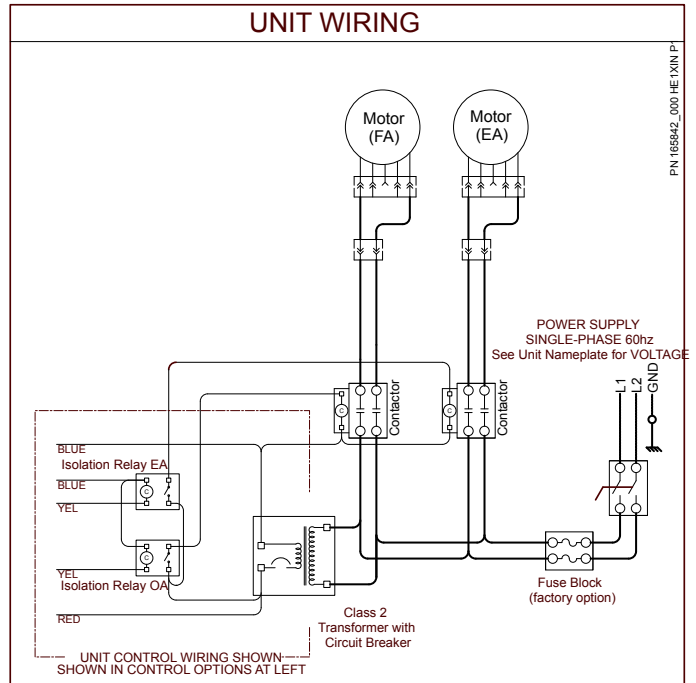
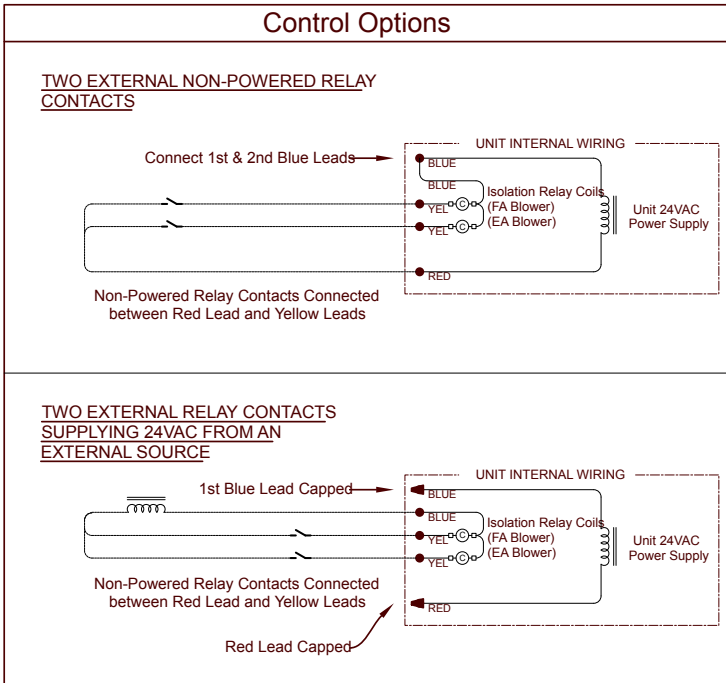

# Wiring Schematics

## HE1XIN P3

## THREE PHASE UNIT - STANDARD

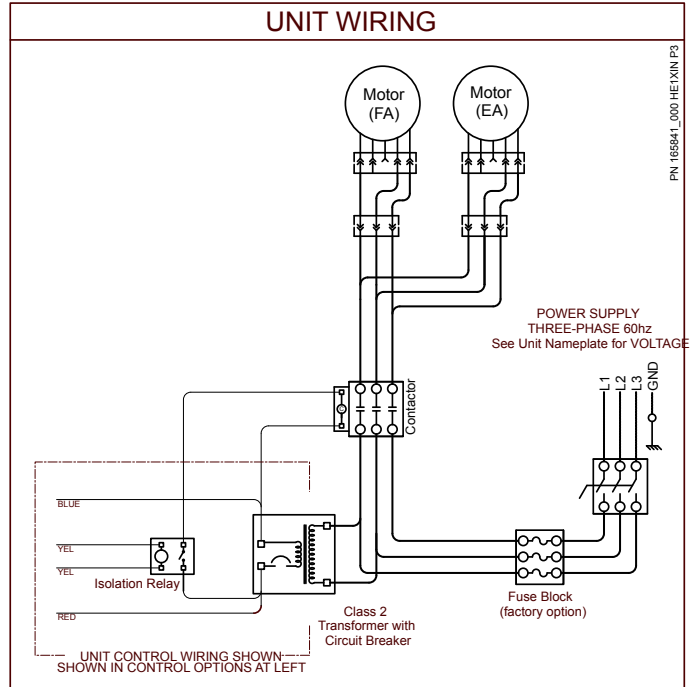
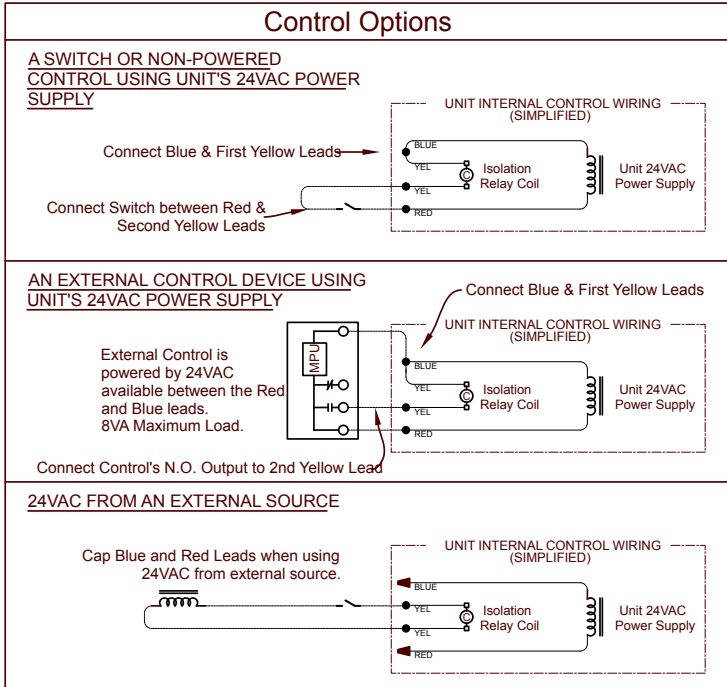

## HE1XIN P3 IBC

## THREE PHASE UNIT WITH INDEPENDENT BLOWER CONTROL

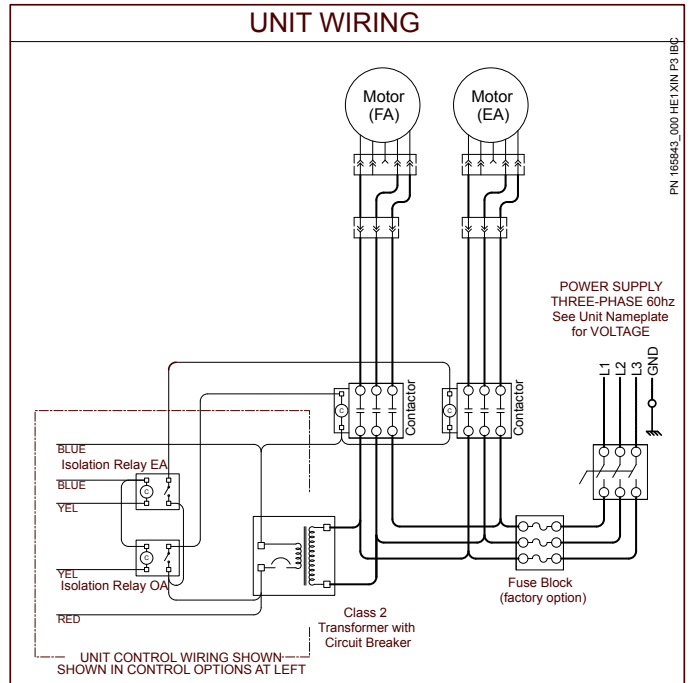
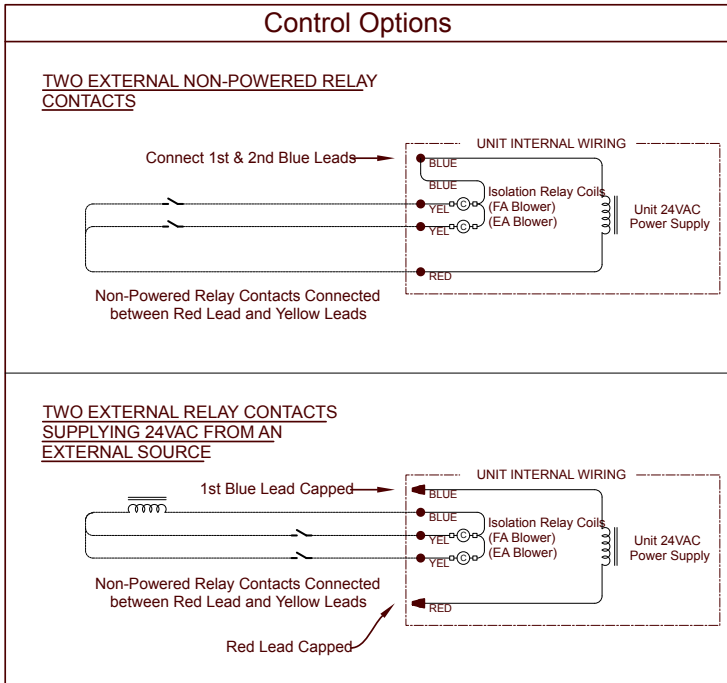

# HE1XINH Replacement Parts

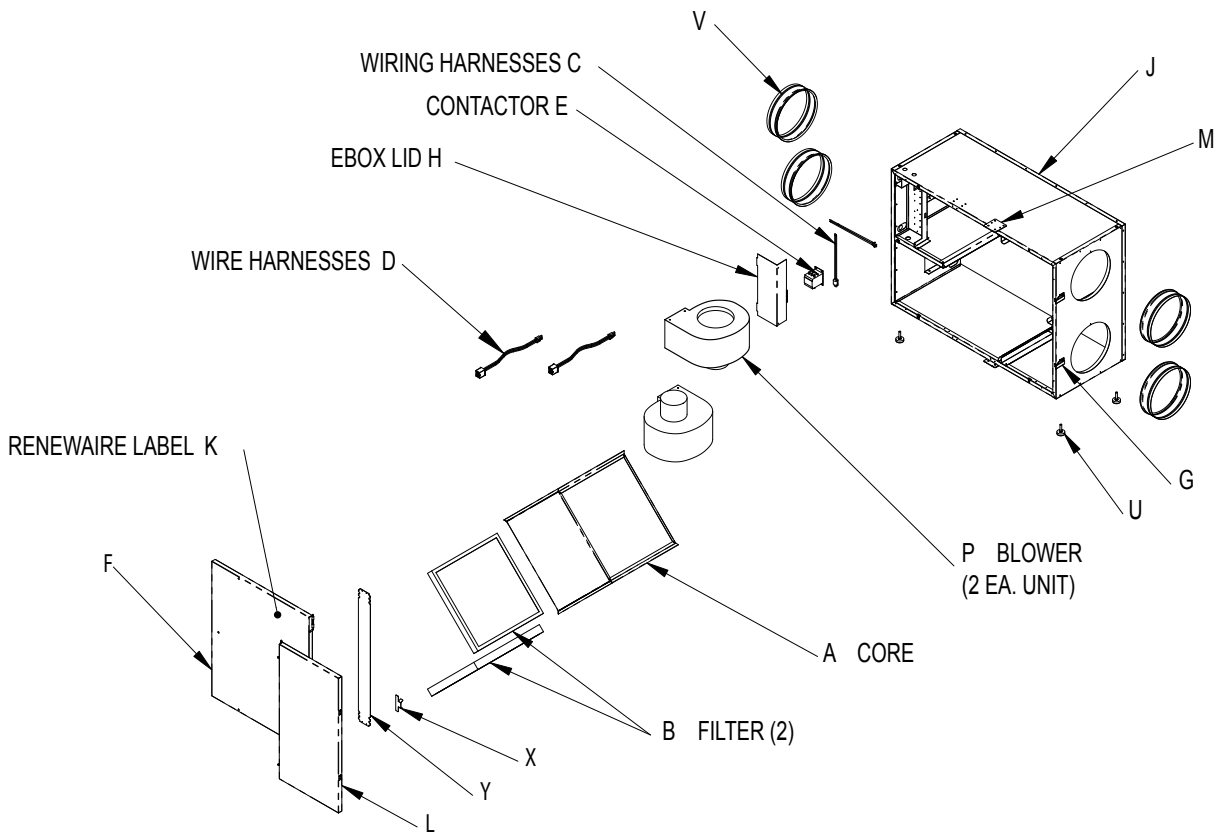

# HE1XINV Replacement Parts

| Description |                           |
|-------------|---------------------------|
| A           | Core Assembly             |
| B           | Filter (set of 2)         |
| C           | Wire Harness, E-box       |
| D           | Voltage Adapters          |
| E           | Contactor                 |
| F           | Blower Access Panel       |
| G           | Latch, Filter Access Door |
| H           | Cover, E-box              |
| J           | Case, Insulated           |
| K           | RenewAire Label           |
| L           | Filter Access Door        |
| M           | Hinge Plate               |
| P           | Housing, Blower           |
| U           | Glide                     |
| V           | Duct Collar               |
| X           | Filter Keeper             |
| Y           | Crossbar, Core            |

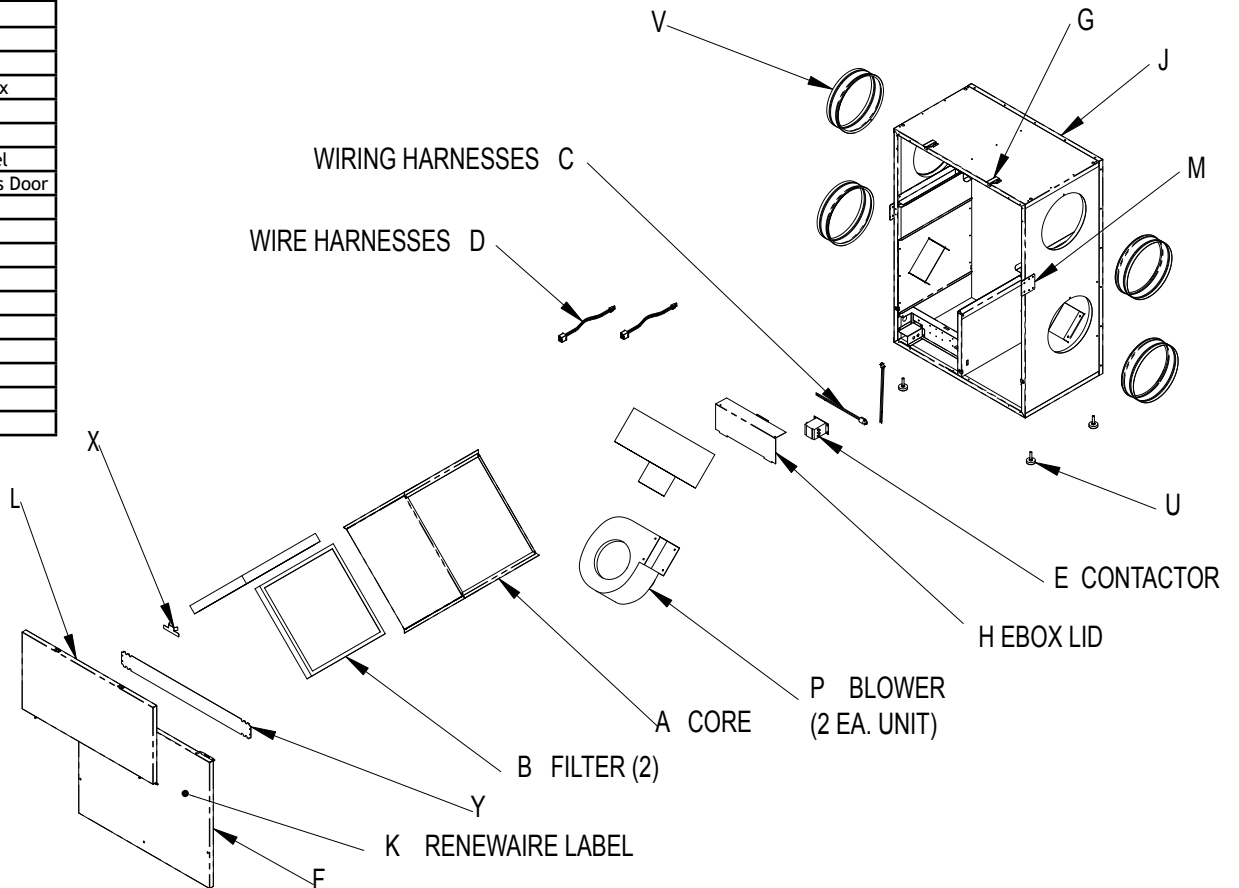



## 24VAC Power Supply Provided with this ERV Unit

This ERV is provided with a Class II 24VAC power supply system that operates the unit's contactor(s) for EV450 and HE1X. The ERV's 24VAC Power Supply can also be used to power the externally-installed controls system: up to 8VA of power is available.

The unit's power supply system includes isolation relay(s) so you can use external controls whose contact ratings are as low as 50mA (1.2VA). Also, it is possible to operate the isolation relays with 24VAC power from an external source (with proper wiring connections).

A built-in circuit-breaker prevents damage to the transformer and other low-voltage components in the event of a short-circuit or overload. In extreme cases, the transformer itself is designed to fail safely.

### CAUTION

1. Connect only to components intended for use with 24VAC power.
2. Do not undersize the low-voltage wires connected to this device. Observe the wire length and gauge limits indicated in this manual.
3. Do not overload this unit's 24VAC power supply system. Confirm that the power requirements of devices you connect to this power supply system do not exceed 8VA in total.
4. If an external source of 24VAC power is used to control the unit, consult the wiring schematics and connect the external power only to the specified terminals in order to avoid damaging the unit or external controls. Connect only CLASS II power to the control terminals of this unit.
5. Unit is not equipped to receive analog signals (such as 1-10vdc or 4-20mA).
6. Unit is not equipped to communicate directly with Building Management Systems (such as BACNET, LONWORKS, etc.). However, the unit can be controlled by powered or non-powered contacts operated by any kind of control system.

#### Specifications

- Nominal Output Voltage under load: 24VAC
- Typical Output Voltage at no load: 29-31V
- Minimum contact rating for connected control device: (50mA (1.2VA)
- Circuit Breaker Trip Point: 3A

## How to Reset the Circuit Breaker

If the transformer is subjected to an excessive load or a short circuit, the circuit breaker will trip to prevent the failure of the transformer. When it trips the circuit breaker's button pops up. Shut off the primary-side power to the unit, and remove the excessive load or the short. The circuit breaker can be reset about fifteen seconds after it trips by pressing in the button.

#### Limits of Power Output

If limits on wire gauge and length are observed, you may connect control devices that draw up to 8VA to the blue and red wires. More than one device can be connected as long as total steady-state load does not exceed 8VA.

|   |      |      |      |      |      |       |
|---|------|------|------|------|------|-------|
| OBSERVE THESE LIMITS TO WIRE LENGTH AND GAUGE, in order to ensure reliable operation of the control system. |      |      |      |      |      |       |
| Wire Gauge  | #22  | #20  | #18  | #16  | #14  | #12   |
| Circuit Length  | 100' | 150' | 250' | 400' | 700' | 1000' |
| <i>"Circuit Length" is distance from ERV to Control Device.</i>   |      |      |      |      |      |       |

### INSTALLATION NOTES

If primary-side voltage is 230VAC, move black primary-side lead from transformer's "208V" terminal to the transformer's terminal marked "240V" ("230V" in some units).

Do not move the black primary-side lead that is connected to the transformer's "COM" terminal.

# Control Wiring Schematics

**NOTE:** The simplified schematics below show only the relevant portions of the low-voltage control circuit in the ERV unit and representational external control approaches. See the complete unit schematics elsewhere in this manual.

## CAUTION

Be careful if the external control system provides 24VAC power at its control output: make sure blue and red leads are separately capped and not connected to any other wires.

- A. Single 2-wire Control:** Use this schematic if the control requires no power to operate and acts like a simple on/off switch. The control must not supply any power to the ERV unit. Connect the blue lead to one yellow lead. Connect the control's contacts to the red lead and the remaining yellow lead.

**Control on separate Power Supply, no power present at Control Output:** Wire as shown for the Single 2-wire control.

## CAUTION

Make sure the control provides no voltage or current at its output terminals.

### A SWITCH OR NON-POWERED CONTROL USING UNIT'S 24VAC POWER SUPPLY

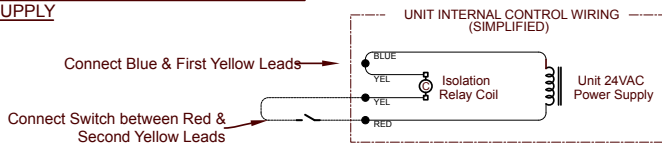

- B. Control Sending 24VAC "On" Signal (from an external power source) to ERV:** Make sure the blue and red leads are separately capped and not connected to any other wires. Now you safely can apply 24VAC to the two yellow leads to operate the ERV's isolation relay.

## CAUTION

Supply only 24VAC (not VDC) from a Class II Power Source.

### 24VAC FROM AN EXTERNAL SOURCE

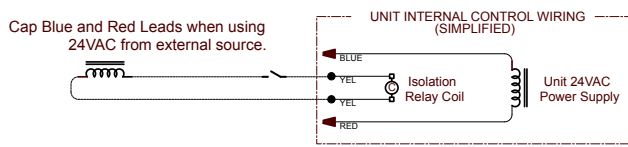

- C. Control operating on Unit's 24VAC Power Supply:** 24VAC power is available at the blue and red leads. **CAUTION:** external control system should not draw more than 8VA. Also connect one of the yellow leads to the blue lead. Connect the switched output of the Control to the red lead to operate the ER's isolation relay.

### AN EXTERNAL CONTROL DEVICE USING UNIT'S 24VAC POWER SUPPLY

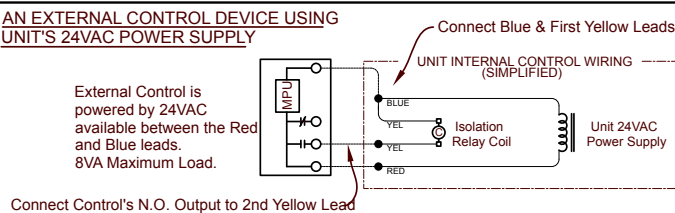

- D. Control System with 2 Non-powered Relay Contacts; ERVs with Independent Blower Control Only:** Use this schematic if the external control system provides no voltage or current at its output contacts. Connect the two blue leads together. Connect the red lead to one side of each of the output contacts. Connect the other side of the output contacts to the appropriate yellow leads (marked "FA Blower" and "EA Blower").

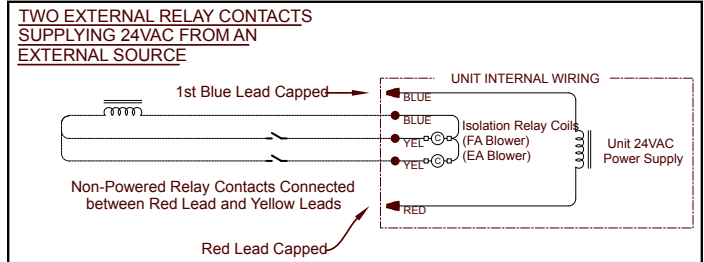

- E. Control System Sending two 24VAC "On" Signals (from an external power source); ERVs with Independent Blower Control Only:** Make sure the blue and red leads are separately capped and not connected to any other wires. Now you safely can apply one of the 24VAC signals to the one of the yellow leads (marked "FA Blower" and "EA Blower") and the red lead to operate one of the ERV's isolation relay. Supply the second 24VAC signal to the other yellow lead and again to the red lead (make sure the polarity of each wire connected to the red lead is the same).

## CAUTION

Supply only 24VAC (not VDC) from a Class II Power Source.

### TWO EXTERNAL RELAY CONTACTS SUPPLYING 24VAC FROM AN EXTERNAL SOURCE

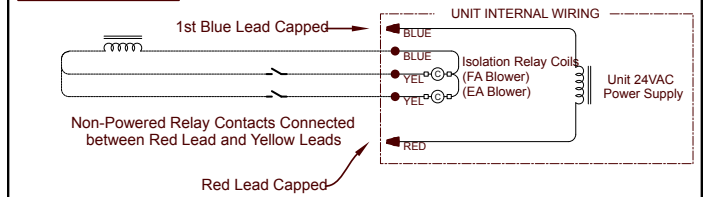

THIS PAGE LEFT BLANK INTENTIONALLY.

## Maintenance

### ⚠ WARNING

Danger of Electrical Shock when servicing an installed unit.

**ALWAYS DISCONNECT POWER SOURCE BEFORE SERVICING!** More than one disconnect switch may be required.

**Proper Wiring Size Selection and Wiring Installation are the Responsibility of the Electrical Contractor.**

*The blower needs no lubrication.*

If necessary vacuum clean the blower wheels at the same time you clean the face of the energy exchange element (annually).

**Inspect and change the filters regularly.**

Inspect and/or replace filters every two or three months when the HE1X is in regular use, or as needed.

1. To access the filters unlatch the filter access door. The filter access door may be removed.
2. Remove filter keeper.
3. Pull the dirty filters out and replace with new filters.
4. Reinstall the filter keeper.

### CAUTION

Do not allow the filter access door to drop when unlatched. Injury to personnel or damage to unit may occur.

### CAUTION

Keep fingers away from between the filter access door and the blower access panel when unlatching and opening the filter access door. Potential PINCH POINT.

NOTE: Filters must be used or the energy exchange core will become blocked by dust and the HE1XIN won't do its job. The filters supplied in the unit are usually able to keep the energy exchange core clear for several months. Finer filters can be used but must be cleaned more often. If using finer filters, their increased resistance to flow must be allowed for in the system design.

**Vacuum the face of the energy exchange element yearly.**

Dust collects only on the entering face of the energy exchange element, right where the filter sits. The interior of the energy exchange element stays clean even if the element faces are dust-covered.

**TO CLEAN THE ENERGY EXCHANGE ELEMENT:**

1. remove the filters (see above)
2. vacuum the exposed faces of the energy exchange element with a soft brush attachment
3. vacuum out dust from the rest of the unit case
4. install new filters

### CAUTION

**DO NOT WASH THE ENERGY EXCHANGE CORE.** Keep it away from water or fire to avoid damaging it. Always handle the core carefully.

Initial Resistance of Filters supplied with this unit:

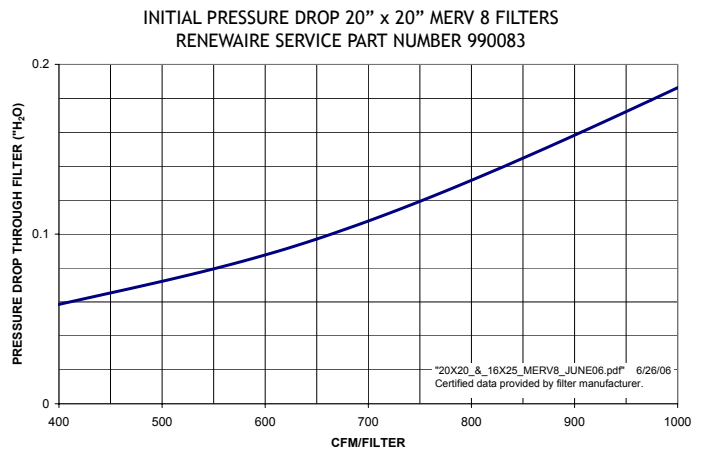

### Filter Specifications:

(2) 20" x 20" x 2"(nominal) pleated filters

Actual size: 19.5" x 19.5" x 1.75"

Unit shipped with MERV-8 Filters

Minimum recommended effectiveness: MERV-6

### CAUTION

Filters must be used or the energy exchange core will become blocked by dust and the unit will not do its job. In extreme cases components may be damaged.