

FIRST FLOOR ROOM FINISH SCHEDULE									
ROOM NO.	ROOM NAME	FLOOR		WALLS				CEILING	NOTES
		FLOOR	BASE	NORTH	SOUTH	EAST	WEST	MATL	
101	ENTRY	TILE/GRATE	TILE	GL	N/A	GL	GL	PTD GWB	METAL WALK OFF GRATE
102	MEETING	TILE	TILE	GL	PTD GWB	GL	GL	PTD GWB	
103	RECEPTION	CRPT.	WOOD	N/A	PTD GWB	PTD GWB	GL	PTD GWB	
104	KITCHEN	TILE	TILE	N/A	N/A	TILE 4/PTD GWB/TILE 4/PTD GWB	PTD GWB	PTD GWB	
105	CAFE	TILE 2	TILE	PTD GWB	PTD GWB	GL	GL	ACT 1	
106	MEETING	TILE 2	TILE	PTD GWB	N/A	GL	PTD GWB	ACT 1	
107	STORAGE	CRPT.	RUBBER	PTD GWB	PTD GWB	PTD GWB	PTD GWB	ACT 2	
108	MULTI-PURPOSE	CRPT.	RUBBER	PTD GWB	PTD GWB	PTD GWB	PTD GWB	ACT 1	
109	CONFERENCE	CRPT.	RUBBER	PTD GWB	PTD GWB	PTD GWB	PTD GWB	ACT 1	
110	MUDROOM	TILE/GRATE	TILE	PTD GWB	PTD GWB	PTD GWB	PTD GWB	PTD GWB	METAL GRATE
111	HALL	TILE	TILE	PTD GWB	PTD GWB	GL	N/A	PTD GWB	
112	RESTROOM	TILE	N/A	PTD GWB/TILE	PTD GWB/TILE	PTD GWB/TILE	PTD GWB/TILE	ACT 2	MUD SET TILE
113	RESTROOM	TILE	N/A	PTD GWB/TILE	PTD GWB/TILE	PTD GWB/TILE	PTD GWB/TILE	ACT 2	MUD SET TILE
114	WATER CLOSET	TILE 1/CRPT	TILE	PTD GWB/TILE	PTD GWB/TILE	PTD GWB/TILE	PTD GWB/TILE	ACT 2	MUD SET TILE
115	MAIL	CRPT	RUBBER	PTD GWB	PTD GWB	PTD GWB	PTD GWB	ACT 2	
116	FITNESS	RF1	RUBBER	PTD GWB	PTD GWB/MIR	PTD GWB	PTD GWB	ACT 1, 2/PTD GWB	
117	MDF + SERVER	RF2	RUBBER	PTD GWB	PTD GWB	PTD GWB	PTD GWB	ACT 2	
118	STORAGE	CONC.	RUBBER	PTD GWB	PTD GWB	PTD GWB	PTD GWB	ACT 2	
118B	VESTIBULE	CONC.	RUBBER	PTD GWB	PTD GWB	PTD GWB	PTD GWB	PTD GWB	
119	SHOWER	TILE	TILE	PTD GWB/TILE	PTD GWB/TILE	PTD GWB/TILE	PTD GWB/TILE	PTD GWB	MUD SET TILE
120	SHOWER	TILE	TILE	PTD GWB/TILE	PTD GWB/TILE	PTD GWB/TILE	PTD GWB/TILE	PTD GWB	MUD SET TILE
121	SHOWER	TILE	TILE	PTD GWB/TILE	PTD GWB/TILE	PTD GWB/TILE	PTD GWB/TILE	PTD GWB	MUD SET TILE
122	SHOWER	TILE	TILE	PTD GWB/TILE	PTD GWB/TILE	PTD GWB/TILE	PTD GWB/TILE	PTD GWB	MUD SET TILE
123	SPRINKLER	EPOXY	EPOXY	EPOXY/BLCK	EPOXY/BLCK	EPOXY/BLCK	EPOXY/BLCK	PTD GWB	CONTINUOUS EPOXY COVE 10" HEIGHT
124	ELECTRICAL	CONC.	RUBBER	PTD GWB	PTD GWB	PTD GWB	PTD GWB	ACT 2	
125	ATRIUM	CRPT	WOOD/MTL	GL	GL	PTD GWB	N/A	WOOD/DECK	
126	ELEVATOR LOBBY	CRPT	WOOD/MTL	N/A	PTD GWB	PTD GWB	PTD GWB	PTD GWB	
127	JANITOR	CONC.	RUBBER	PTD GWB	PTD GWB	PTD GWB	PTD GWB	PTD GWB	
128	JANITOR	CONC.	RUBBER	PTD GWB	PTD GWB	PTD GWB	PTD GWB	PTD GWB	
ST01	STAIR 01	TILE 3	TILE	N/A	N/A	N/A	N/A	N/A	STEEL PAN STAIR W/ GLASS GUARDS AND WOOD HANDRAILS
ST02	STAIR 02	CONC.	RUBBER	PTD GWB	PTD GWB	PTD GWB	PTD GWB	PTD GWB	1HR RATED ASSEMBLIES REQUIRED (RUBBER T-R AT STAIR)
ST03	STAIR 03	CONC.	RUBBER	PTD GWB	PTD GWB	PTD GWB	PTD GWB	PTD GWB	1HR RATED ASSEMBLIES REQUIRED (RUBBER T-R AT STAIR)

FINISH LEGEND	
NOTE	DESCRIPTION
FLOOR	
GRATE	RECESSED FLOOR GRATE
CONC.	SEALED CONCRETE SLAB
CARPET	CARPET
TILE	PORCELAIN TILE
TILE 2	PORCELAIN TILE
TILE 3	PORCELAIN TILE
EPOXY	EPOXY COATING
RF1	RESILIENT FLOOR
RF2	RESILIENT FLOOR
BASE	
RUBBER	RUBBER BASE
TILE	TILE COVE BASE / 2"
TILE 2	TILE COVE BASE / 2"
TILE 3	TILE COVE BASE / 2"
WOOD	2" WOOD BASE W/ CLR FINISH
METAL	2-1/2" CLEAR ANODIZED ALUMINUM REVEAL BASE TRIM
WALL	
PTD GWB	PAINTED GYPSUM WALL BOARD
GL	STOREFRONT GLASS SYSTEM
TILE	CERAMIC TILE
TILE 4	GLASS TILE
EPOXY	EPOXY COATING
BLCK	CMU BLOCK
CEILING	
ACT 1	2X6 PLANK ACOUSTIC CEILING TILE
ACT 2	2X2 ACOUSTIC CEILING TILE
WOOD	FINISHED PLYWOOD/PANELIZED
PTD GWB	PTD GWB
DECK	EXPOSED WOOD DECK

GENERAL NOTES:

- SEE INTERIOR ELEVATIONS FOR MORE INFO.
- PROTECT STRUCTURE DURING CONSTRUCTION IN AREAS TO BE EXPOSED. FINISH EXPOSED STRUCTURE W/ CLEAR MATTE FINISH.
- SEE ELECTRICAL DRAWINGS FOR FLOOR BOXES AND ADDITIONAL INFORMATION

EXTERIOR THRESHOLDS: DETAILS SEE A602

- CRPT/RF > OUTSIDE
- WALK OFF GRATE > OUTSIDE
- CONCRETE > OUTSIDE

INTERIOR THRESHOLDS: DETAILS SEE A121

- WALK OFF GRATE > TILE
- WALK OFF GRATE > CRPT (DOOR)
- CRPT > CONCRETE
- TILE > CRPT
- TILE > RF OR CONCRETE
- TILE > CRPT (SLIDER)
- TILE > TILE (MUD SET)

SUPPLEMENTAL REFERENCE- FINISH FLAME SPREAD - NO CHANGE TO PROJECT SCOPE

Type X GWB: Flame Spread rating of 15 and Smoke Developed rating of 0, in accordance with ASTM E 84. (as a note, even standard GWB has flame spread of 20)

ACT Armstrong Ultima Shiplap, No. 1989, Flame Spread Index 25 or less. Smoke Developed Index 50 or less (UL labeled.)

Based on the document "Design for Code Acceptance - Flame Spread Performance of Wood Products Used for Interior Finish" from the American Wood Council.

Southern Yellow Pine - Glulam and Roof Decking, meets Class B Flame Spread with 70.

Open wall shelving - melamine over particle board, Flame Spread Index 15 or less. Smoke Developed Index 5 or less.

Wood Ceilings, southern yellow pine to match decking, Class B.

T & G Finish Wall, southern yellow pine to match decking, Class B.

Plastic Laminate Cabinets, Flame Spread Index 15 or less. Smoke Developed Index 95 or less.

Solid Surfacing, Class A, Flame Spread Index 25 or less. Smoke Developed Index 25 or less.

Wood Cabinets, in room 104 white maple plywood, Class C as indicated above.

Flush Wood Doors, birch plywood, provided per WDMA I.S. 1A-11

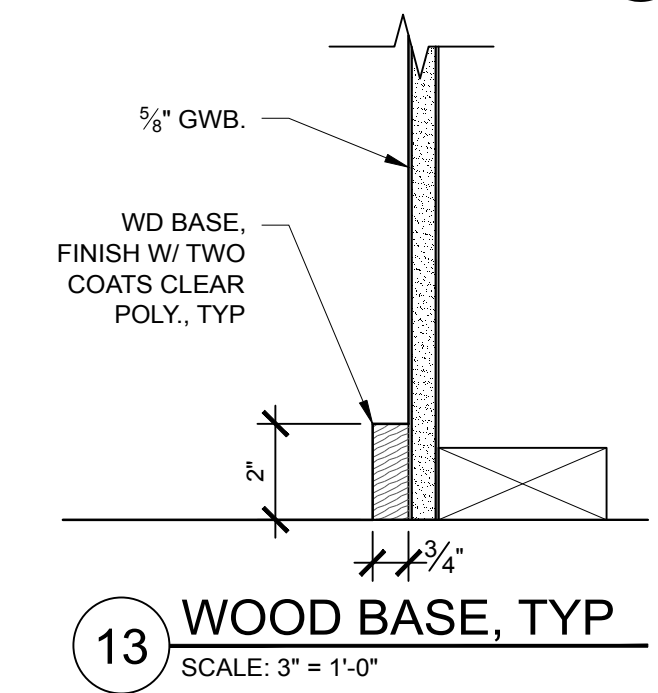
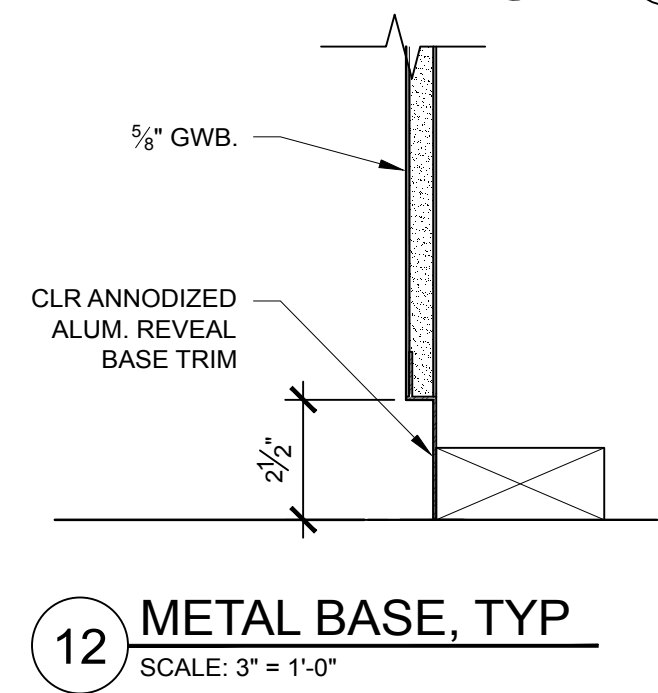

- SEE DOOR DETAILS A/602 FOR EXTERIOR THRESHOLD CONDITIONS
- 1-3 Floor Transition Detail**
SCALE: 3" = 1'-0"
 - 4 Floor Transition Detail**
SCALE: 3" = 1'-0"
 - 5 Floor Transition Detail**
SCALE: 3" = 1'-0"
 - 6 Floor Transition Detail**
SCALE: 3" = 1'-0"
 - 7 Floor Transition Detail**
SCALE: 3" = 1'-0"

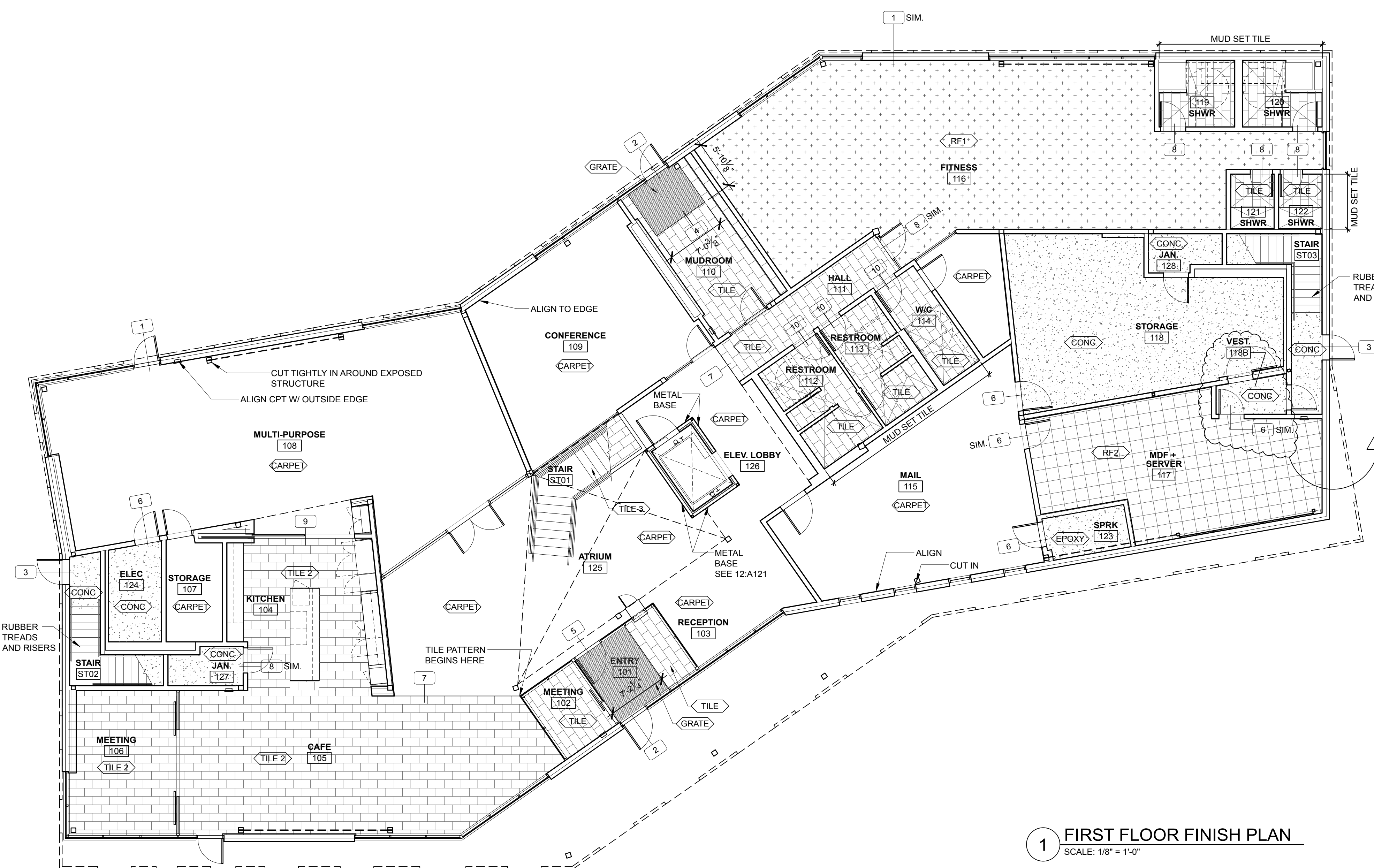

- 8 Floor Transition Detail**
SCALE: 3" = 1'-0"
- 9 Floor Transition Detail**
SCALE: 3" = 1'-0"
- 10 Floor Transition Detail**
SCALE: 3" = 1'-0"
- 11 Floor Transition Detail**
SCALE: 3" = 1'-0"



75 York Street
Portland, Maine 04101
simonsarchitects.com
207.772.4656

PROJECT NAME:
PATRONS OXFORD OFFICES
97 TECHNOLOGY PARK DRIVE
PORTLAND, MAINE 04102
UNITED STATES OF AMERICA

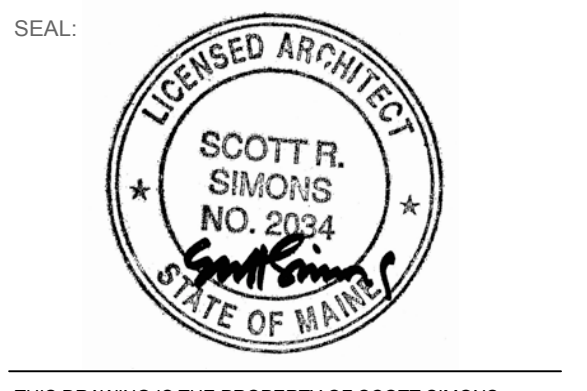

THIS DRAWING IS THE PROPERTY OF SCOTT SIMONS ARCHITECTS (SSA) AND IS NOT TO BE COPIED OR REPRODUCED IN PART OR WHOLE. © 2016 © SCOTT SIMONS ARCHITECTS, LLC.

REVISION:	DATE
ADDENDUM 01 (INCLUDED)	25 JANUARY 2016
ADDENDUM 02 (INCLUDED)	01 FEBRUARY 2016
ADDENDUM 03 (INCLUDED)	26 FEBRUARY 2016
ADDENDUM 04 (CLOUDED)	14 MARCH 2016
5	DATE
6	DATE

DATE OF ISSUE: 14 MARCH 2016
PROJECT NUMBER: 2015-0100 PATRONS OXFORD
STATUS: CONSTRUCTION DOCUMENTS CONFORMANCE SET

FIRST FLOOR FINISH PLAN

A121
CONFORMANCE SET