

DISPLAY THIS CARD ON PRINCIPAL FRONTAGE OF WORK CITY OF PORTLAND

Please Read Application And Notes, If Any, Attached

INSPECTION

PERMIT

Permit Number: 060936

This is to certify that REW REALTY LLC /Strom Water Construction

has permission to Portland Board of Relators - want fit-

AT 2273 CONGRESS ST

L 238A A005001

PERMIT ISSUED
JUL 11 2006
CITY OF PORTLAND

provided that the person or persons who accept this permit shall comply with all of the provisions of the Statutes of the State and of the Ordinances of the City of Portland relating to the construction, maintenance and use of buildings and structures, and of the application on file in this department.

Apply to Public Works for street line and grade if nature of work requires such information.

Notification of inspection must be given and when permission proceeds before this building or part thereof is started or closed-in 24 HOUR NOTICE IS REQUIRED.

A certificate of occupancy must be procured by owner before this building or part thereof is occupied.

OTHER REQUIRED APPROVALS

Fire Dept. _____
Health Dept. _____
Appeal Board _____
Other _____
Department Name

[Signature]
Director - Building & Inspection Services

PENALTY FOR REMOVING THIS CARD

City of Portland, Maine - Building or Use Permit Application

389 Congress Street, 04101 Tel: (207) 874-8703, Fax: (207) 874-8716

Permit No: 06-0936	Issue Date:	CBL: 238A A005001
-----------------------	-------------	----------------------

Location of Construction: 2273 CONGRESS ST	Owner Name: REW REALTY LLC	Owner Address: PO BOX 3889	Phone: 207-650-7802
Business Name:	Contractor Name: Stroudwater Construction	Contractor Address: 96 Ocean St unit 1 Portland	Phone: 207-650-7802
Lessee/Buyer's Name	Phone:	Permit Type: Alterations - Commercial	Zone: FM
Past Use: Commercial/ Portland Board of Relators	Proposed Use: Commercial/ Portland Board of Relators - tenant fit-up	Permit Fee: \$246.00	Cost of Work: \$24,350.00
Proposed Project Description: Portland Board of Relators - tenant fit-up		FIRE DEPT: <input checked="" type="checkbox"/> Approved <input type="checkbox"/> Denied TB NFP# 101	INSPECTION: Use Group B Type: 26 7/11/06 Signature: [Signature]
		Signature: [Signature]	Signature: [Signature]
PEDESTRIAN ACTIVITIES DISTRICT (P.A.D.)			
Action: <input type="checkbox"/> Approved <input type="checkbox"/> Approved w/Conditions <input type="checkbox"/> Denied			
		Signature:	Date:

PERMIT ISSUED
JUL 11 2006
CITY OF PORTLAND
CEO District

Permit Taken By: Idobson	Date Applied For: 06/21/2006	Zoning Approval
-----------------------------	---------------------------------	------------------------

<p>1. This permit application does not preclude the Applicant(s) from meeting applicable State and Federal Rules.</p> <p>2. Building permits do not include plumbing, septic or electrical work.</p> <p>3. Building permits are void if work is not started within six (6) months of the date of issuance. False information may invalidate a building permit and stop all work..</p>	<p>Special Zone or Reviews</p> <p><input type="checkbox"/> Shoreland</p> <p><input type="checkbox"/> Wetland</p> <p><input type="checkbox"/> Flood Zone</p> <p><input type="checkbox"/> Subdivision</p> <p><input type="checkbox"/> Site Plan</p> <p>Maj <input type="checkbox"/> Minor <input type="checkbox"/> MM <input type="checkbox"/></p> <p>Date: 6/29/06</p>	<p>Zoning Appeal</p> <p><input type="checkbox"/> Variance</p> <p><input type="checkbox"/> Miscellaneous</p> <p><input type="checkbox"/> Conditional Use</p> <p><input type="checkbox"/> Interpretation</p> <p><input type="checkbox"/> Approved</p> <p><input type="checkbox"/> Denied</p> <p>Date:</p>	<p>Historic Preservation</p> <p><input checked="" type="checkbox"/> Not in District or Landmark</p> <p><input type="checkbox"/> Does Not Require Review</p> <p><input type="checkbox"/> Requires Review</p> <p><input type="checkbox"/> Approved</p> <p><input type="checkbox"/> Approved w/Conditions</p> <p>Denied</p> <p>Date:</p>
---	--	--	--

CERTIFICATION

I hereby certify that I am the owner of record of the named property, or that the proposed work is authorized by the owner of record and that I have been authorized by the owner to make this application as his authorized agent and I agree to conform to all applicable laws of this jurisdiction. In addition, if a permit for work described in the application is issued, I certify that the code official's authorized representative shall have the authority to enter all areas covered by such permit at any reasonable hour to enforce the provision of the code(s) applicable to such permit.

SIGNATURE OF APPLICANT	ADDRESS	DATE	PHONE
RESPONSIBLE PERSON IN CHARGE OF WORK, TITLE		DATE	PHONE

City of Portland, Maine - Building or Use Permit

389 Congress Street, 04101 Tel: (207) 874-8703, Fax: (207) 874-8716

Permit No: 06-0936	Date Applied For: 06/21/2006	CBL: 238A A005001
------------------------------	--	-----------------------------

Location of Construction: 2273 CONGRESS ST	Owner Name: REW REALTY LLC	Owner Address: PO BOX 3889	Phone:
Business Name:	Contractor Name: Stroudwater Construction	Contractor Address: 96 Ocean St unit 1 Portland	Phone: (207) 650-7802
Lessee/Buyer's Name	Phone:	Permit Type: Alterations - Commercial	

Proposed Use: Commercial/ Portland Board of Relators - tenant fit-up	Proposed Project Description: Portland Board of Relators - tenant fit-up
--	--

--

Dept: Building **Status:** Approved with Conditions **Reviewer:** Mike Nugent **Approval Date:** 07/11/2006
Note: **Ok to Issue:**
 1) The Building has been reclassified as a Type 5 combustible building in conformity with Table 503 of the IBC. Wood Studs may be used.

Dept: Fire **Status:** Approved with Conditions **Reviewer:** Cptn Greg Cass **Approval Date:** 07/05/2006
Note: **Ok to Issue:**
 1) All building construction shall comply with NFPA 101

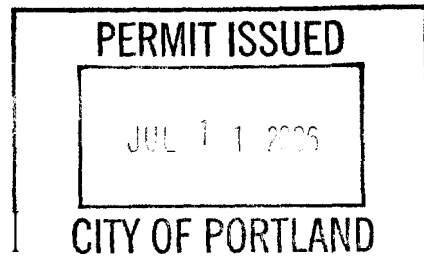



PORTLAND BOARD OF REALTORS®

Executive Offices
558 Brighton Avenue, Portland, Maine 04102
Telephone (207) 775-1097 Fax (207) 774-8880
Email: pbr@maine.rr.com
www.portlandboardofrealtors.com

City of Portland
Michael Nugent, 874-8700
Department of Building Inspections
389 Congress St.
Portland, ME 04101

RE: 2271 Congress St, Portland ME 04102
Building Permit CBL: 238 AA 005

July 11, 2006

Dear Mr. Nugent:

I request the above referenced building to be re-classified as construction type: 5B-unprotected, combustibile (IBC 602.5).

This building will be used as office space for 3 employees. Total square footage of the building is 3,100.

Please let me know if you need any further information on the building.

Regards,

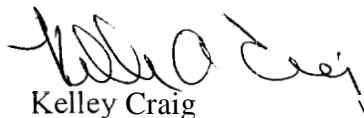

Kelley Craig

Executive Officer
Portland Board of REALTORS®



General Building Permit Application

If you or the property owner owes real estate or personal property taxes or **uset** charges on any property within the City, **payment arrangements must be made** before permits of any kind are accepted.

Total Square Footage of Proposed Structure 3111			Square Footage of Lot		
Tax Assessor's Chart, Block & Lot Chart# Block# Lot# 238 AA 005		Owner: Portland Board of Realtors		Telephone: 775-1097	
Lessee/Buyer's Name (If Applicable) Portland Board of Realtors 558 Brighton Ave Portland, ME 04107		Applicant name, address & telephone: Portland Board of Realtors		Cost Of Work: \$24,350 Fee: \$ 246 C of O Fee: \$	
Current Specific use: <u>Office Space</u> Proposed Specific use: <u>Office Space</u>					
Project description: Reconfigure internal space for better use of Board of Realtors to include meeting rooms					
Contractor's name, address & telephone: Who should we contact when the permit is ready: <u>David Cimino</u> Mailing address: <u>Stroddwater Construction</u> Phone: <u>7&79111</u> <u>96 Ocean St</u> <u>South Portland, ME 04106</u>					

Please submit all of the information outlined in the Commercial Application Checklist. Failure to do so will result in the automatic denial of your permit.

In order to be sure the City fully understands the full scope of the project, the Planning and Development Department may request additional information prior to the issuance of a permit. For further information visit us on-line at www.portlandmaine.gov, stop by the Building Inspections office, room 345 City Hall or call 8748703.

I hereby certify that I am the Owner of record of the named property, or that the owner of record authorizes the proposed work and that I have been authorized by the owner to make this application as his/her authorized agent. I agree to conform to all applicable laws of this jurisdiction. In addition, if a permit for work described in this application is issued, I certify that the Code Official's authorized representative shall have the authority to enter all areas covered by this permit at any reasonable hour to enforce the provisions of the codes applicable to this permit.

Signature of applicant: [Signature] T. A. P. S. P. R.	Date: 6/21/06
--	----------------------

This is not a permit; you may not commence ANY work until the permit is issued.

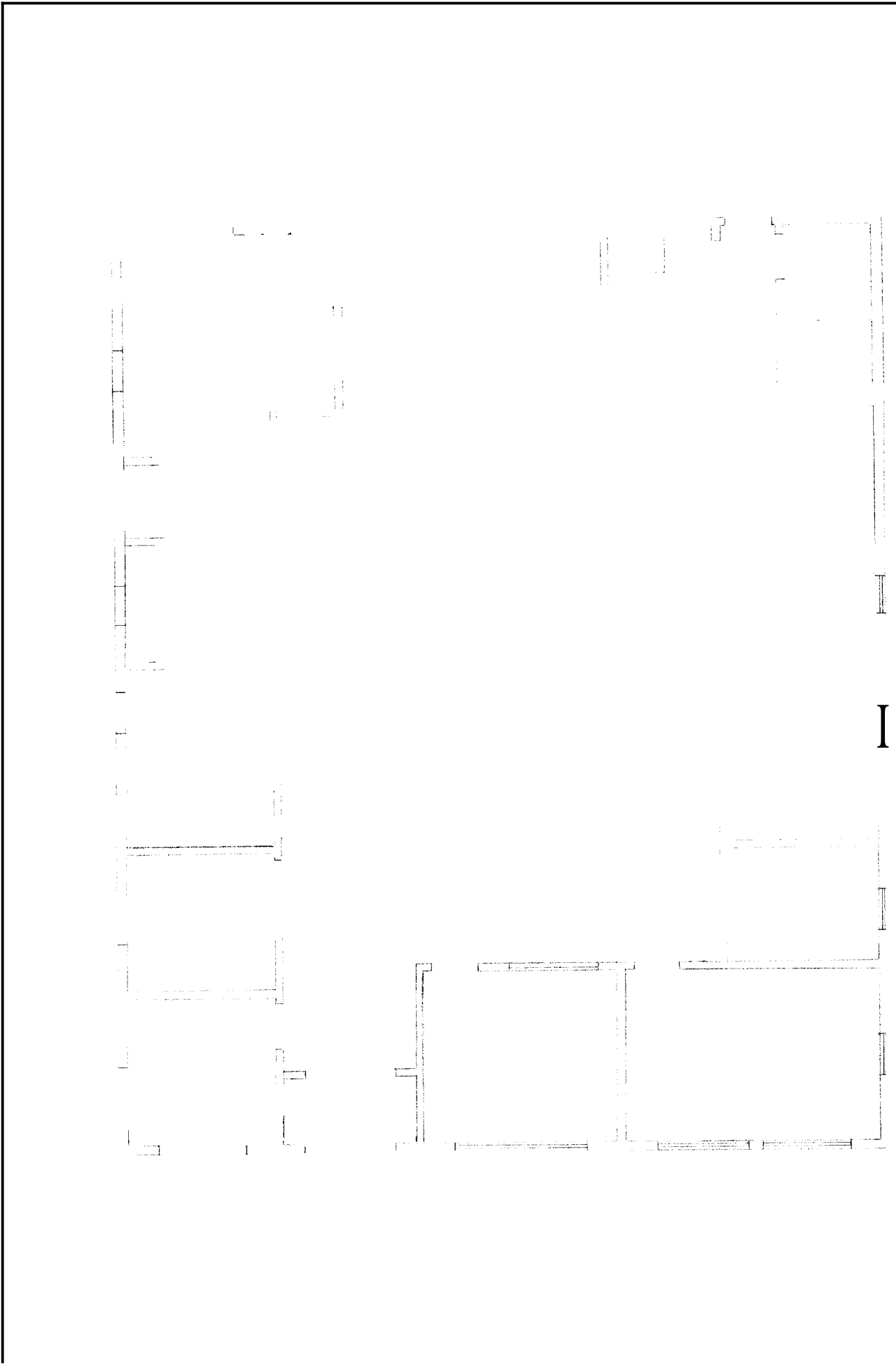

BOARD	2006
APPROVED	DRAWN BY (P)
REVISION	
CONCRETE	
S. PLAN	
DRAWING NUMBER	1

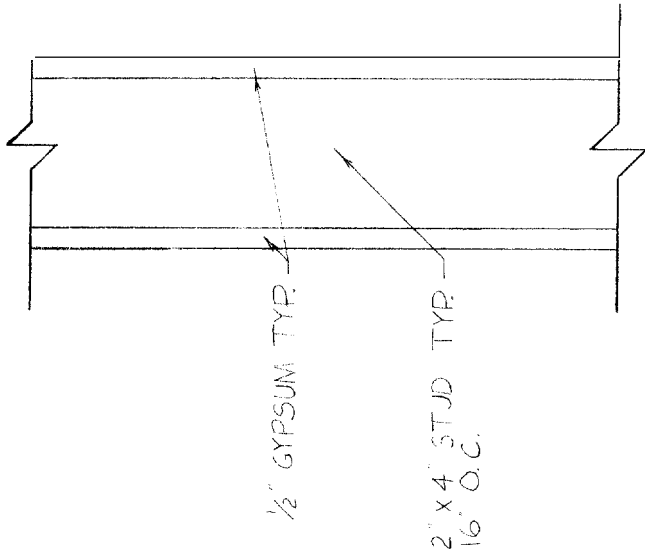

(A) WALL CROSS SECTION
1

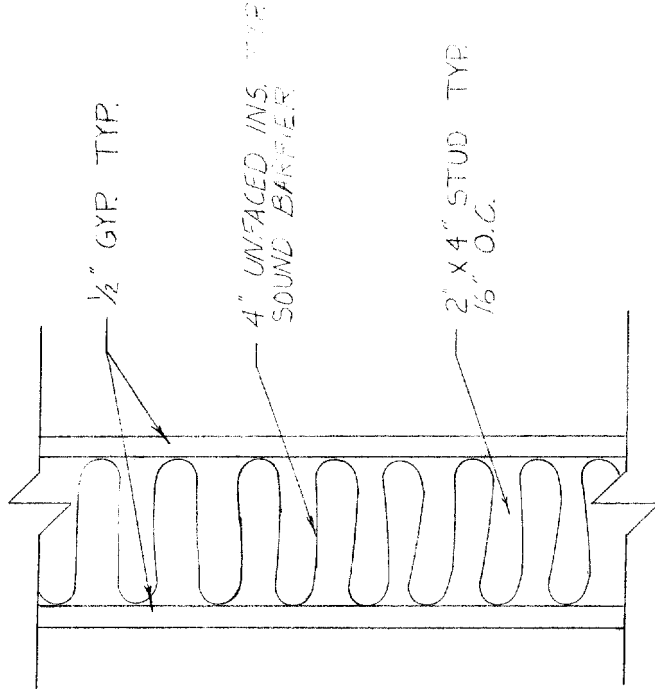

(B) INS. WALL CROSS SECTION
1

PORTLAND BOARD OF REALTORS 2006

SCALE: $\frac{1}{2}$ " = 1'
 DATE: 06/19/06
 APPROVED BY: [Signature]
 DRAWN BY: [Signature]
 REVIEWED: [Signature]

2271 CONGRESS STREET

DRAWING NUMBER

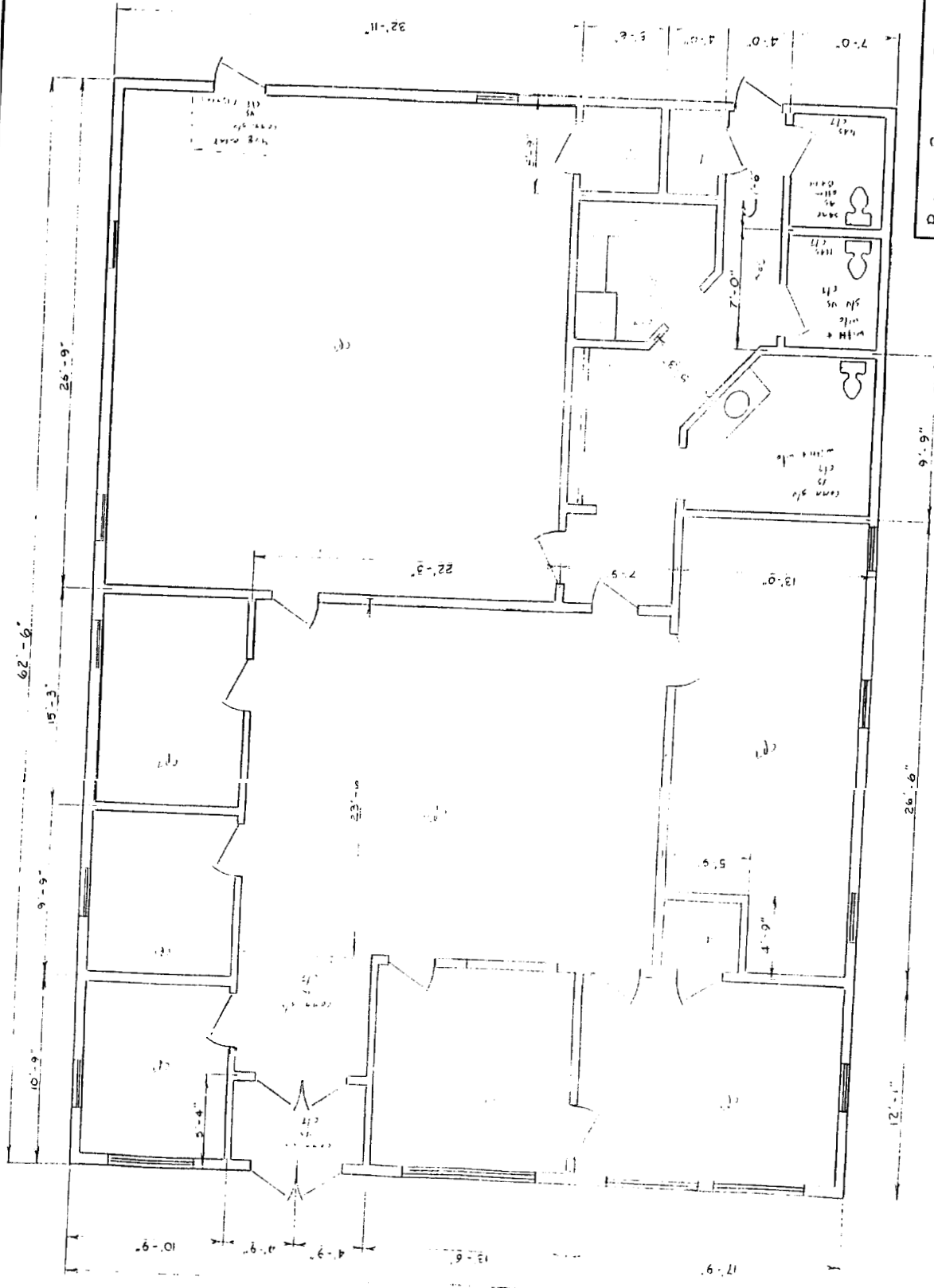

PORTLAND BOARD OF REALTORS 2306
 DRAWN BY: [Signature]
 DATE: 5-18-00
 APPROVED BY: [Signature]
 DATE: 5-15-00
 2271 CONGRESS STREET
 PORTLAND, OR