

C1 TYPICAL PLATE TO BEAM WELDING DETAIL
 NO SCALE REF: NA

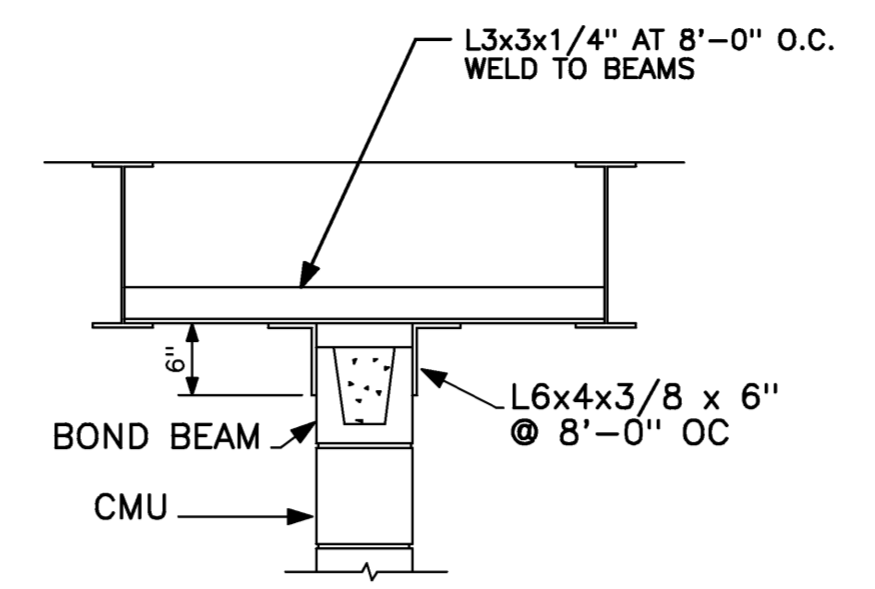

C2 TOP OF PARTITION SUPPORT PARALLEL TO JOIST
 NO SCALE REF: NA

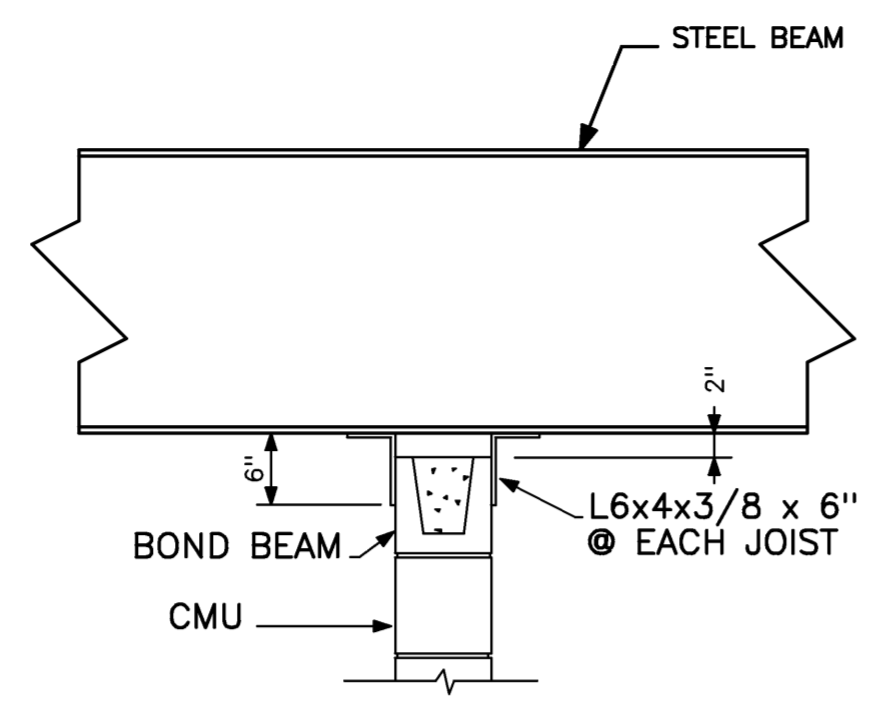

C3 TOP OF PARTITION SUPPORT PERPENDICULAR TO JOISTS OR BEAMS
 NO SCALE REF: NA

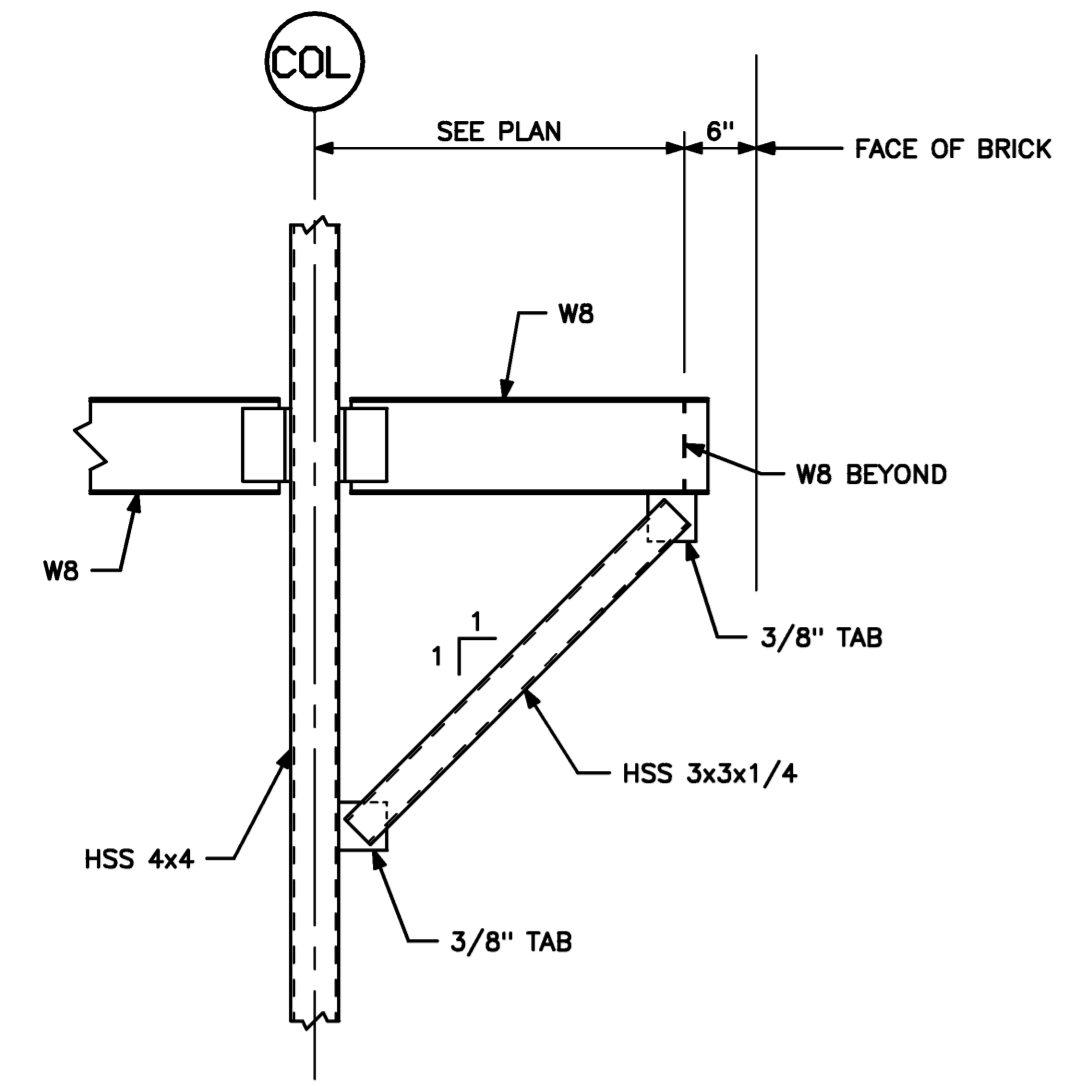

C4 SECTION
 3/4" = 1'-0" REF: S20.1, S20.2, S30.1

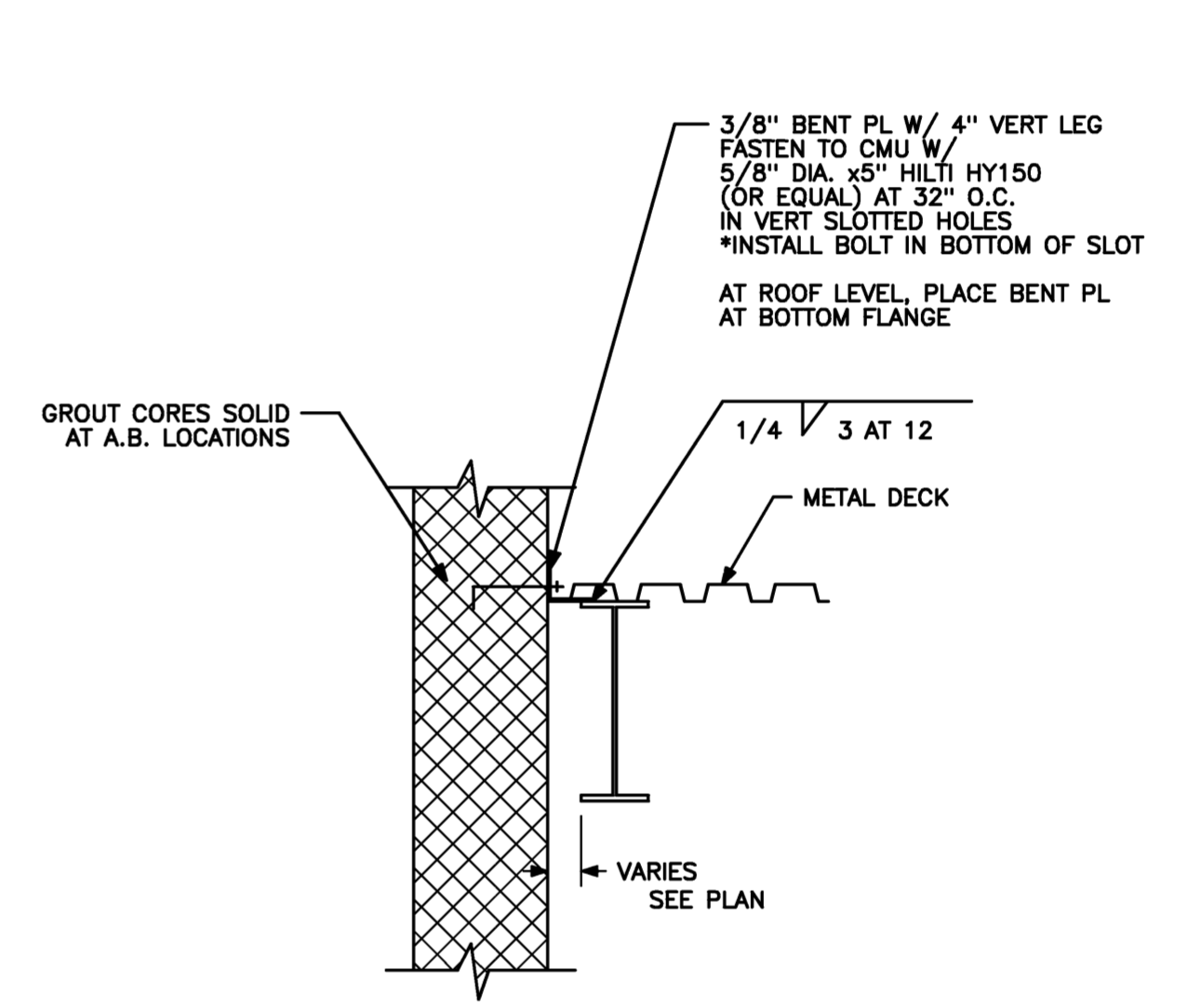

B1 FLOOR/ROOF FRAMING ATTACHMENT TO ELEVATOR/STAIRTOWER
 NO SCALE REF: NA

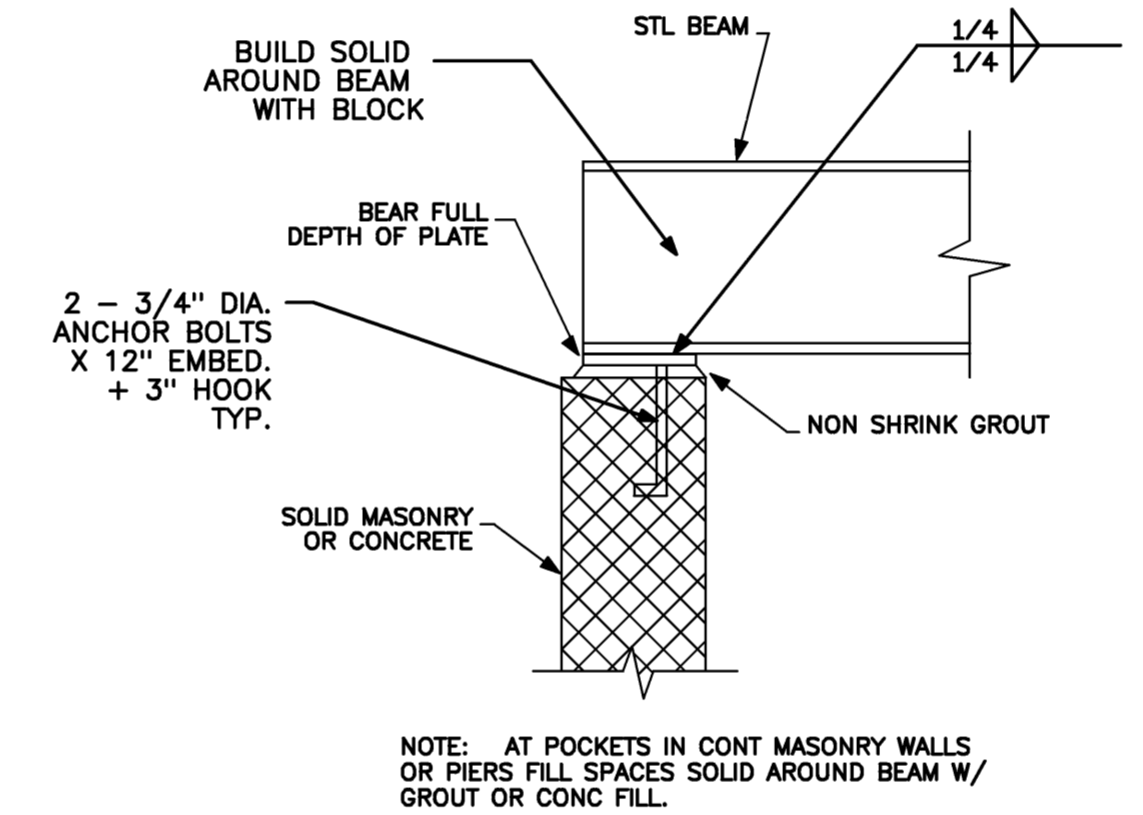

B2 TYPICAL BEAM BEARING DETAIL
 NO SCALE REF: NA

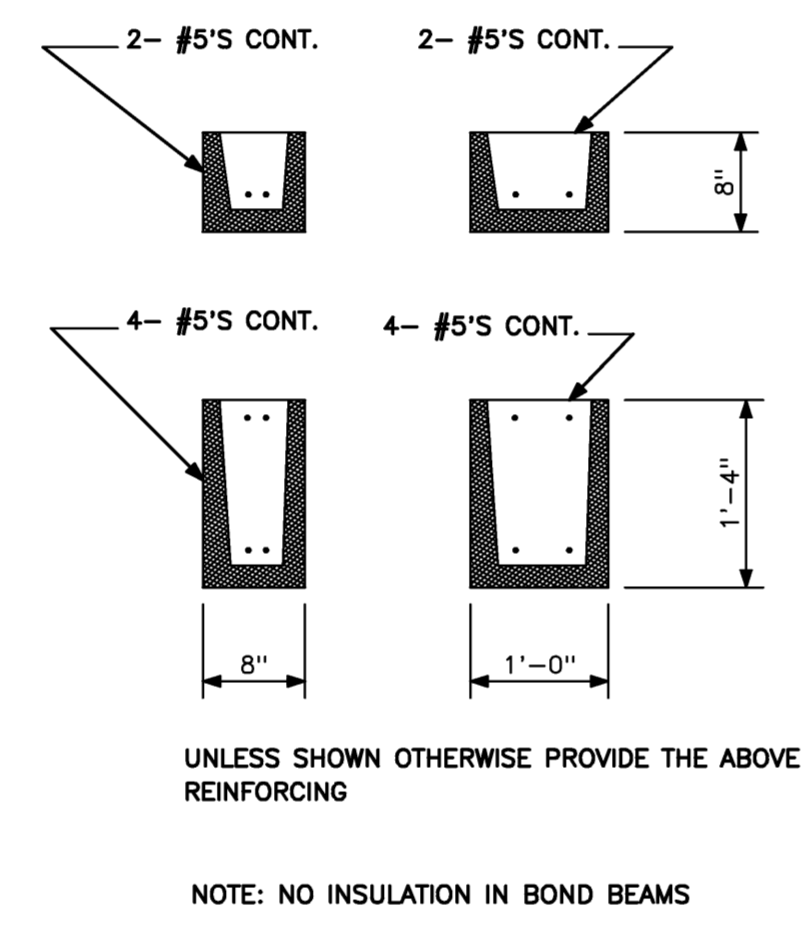

B3 TYPICAL CMU BOND BEAM REINFORCING
 NO SCALE REF: NA

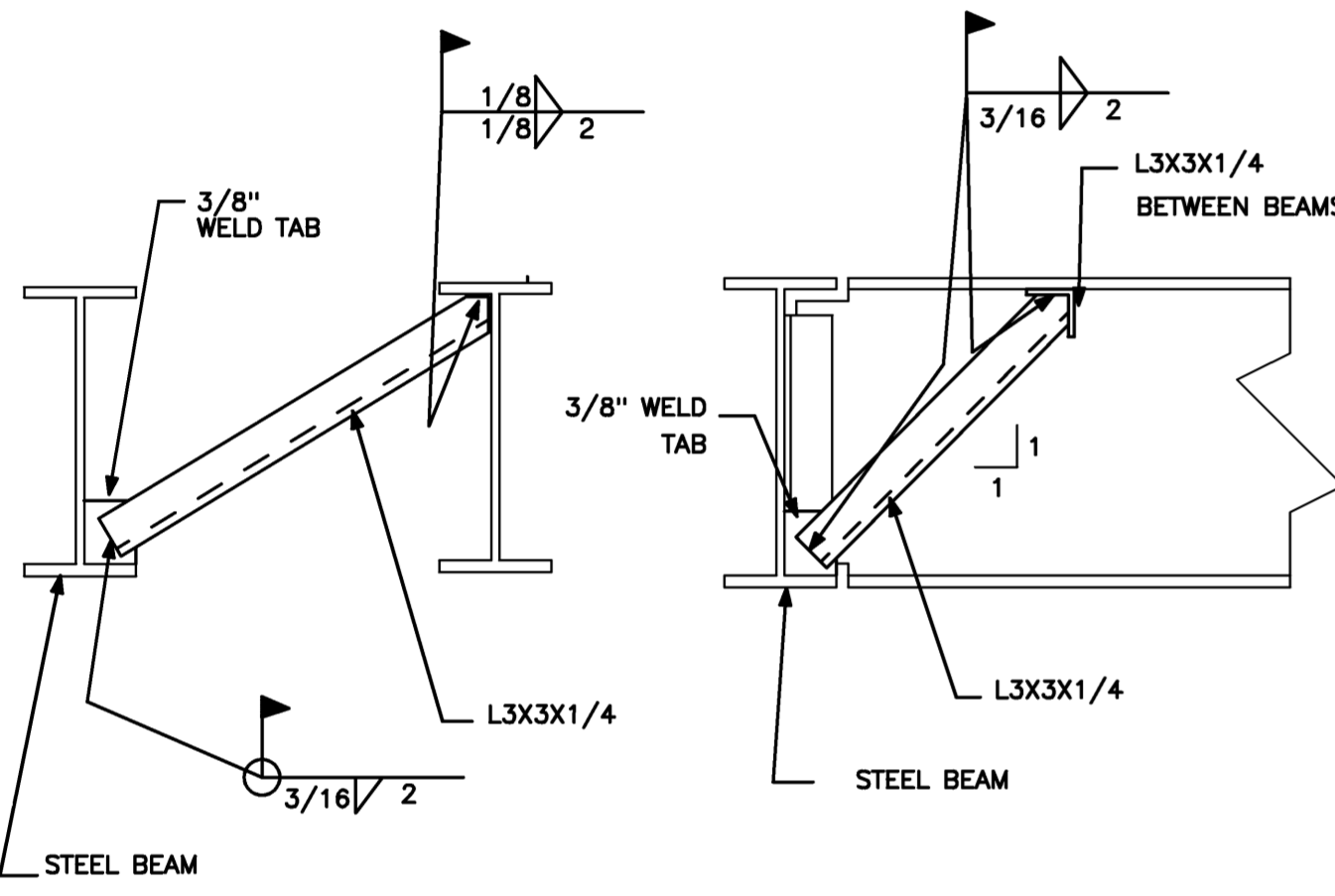

B4 TYPICAL BEAM BRACE DETAIL
 NO SCALE REF: NA

- NOTES:
1. TYPICAL AT ALL PERIMETER BEAMS USE TYPE C AT CANTILEVERED BEAM AREAS (IE. LOBBY)
 2. SPACE AT 8'-0" O.C. MAX. EXCEPT AT CANTILEVERED AREAS, PLACE 1 BRACE AT CENTERLINE OF EACH CANTILEVER BEAM. (MINIMUM ONE BRACE AT MID-SPAN OF BEAM) OR AS SHOWN ON PLAN.

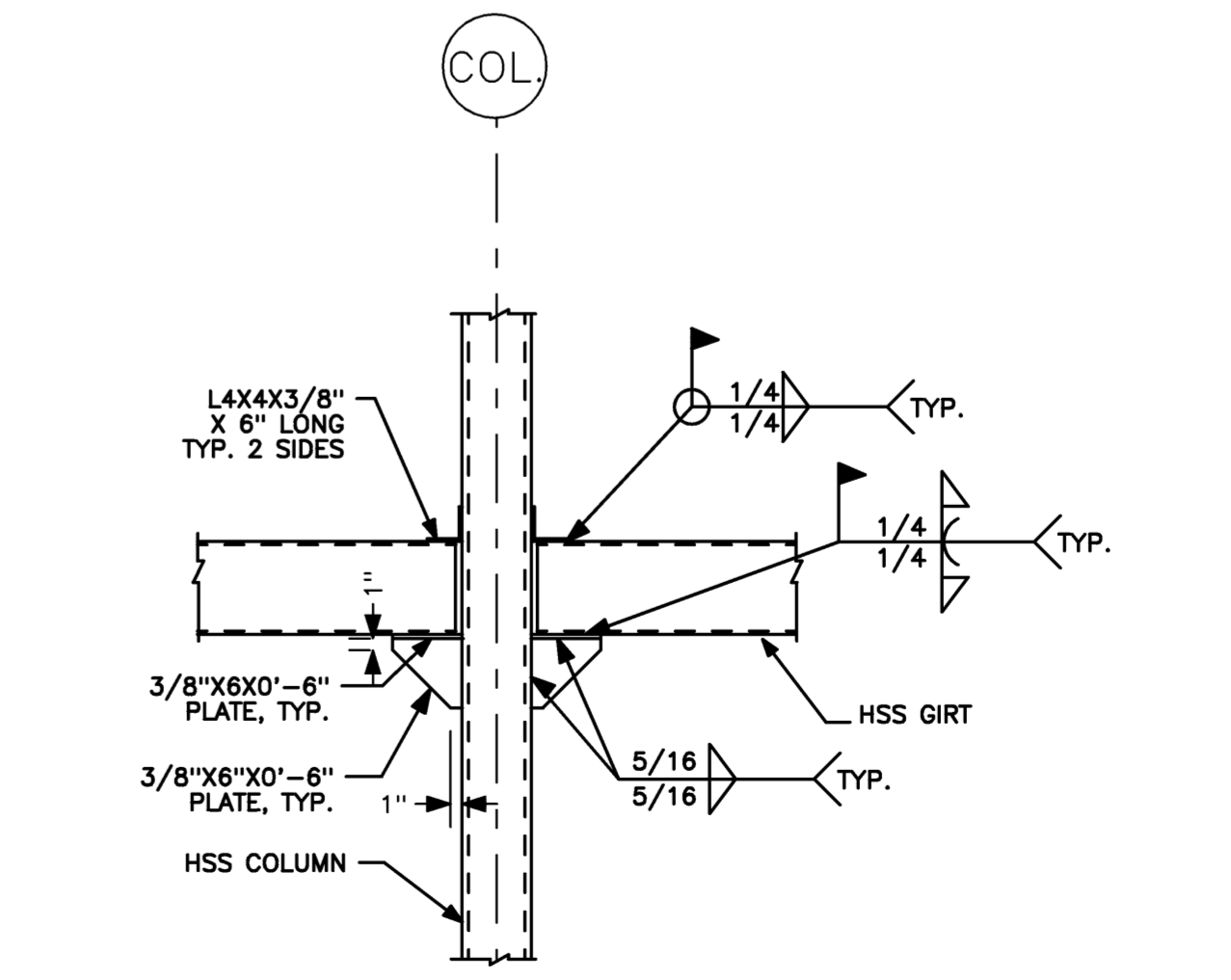

A1 TYPICAL HSS GIRT TO HSS COLUMN CONNECTION
 3/4" = 1'-0" REF: NA

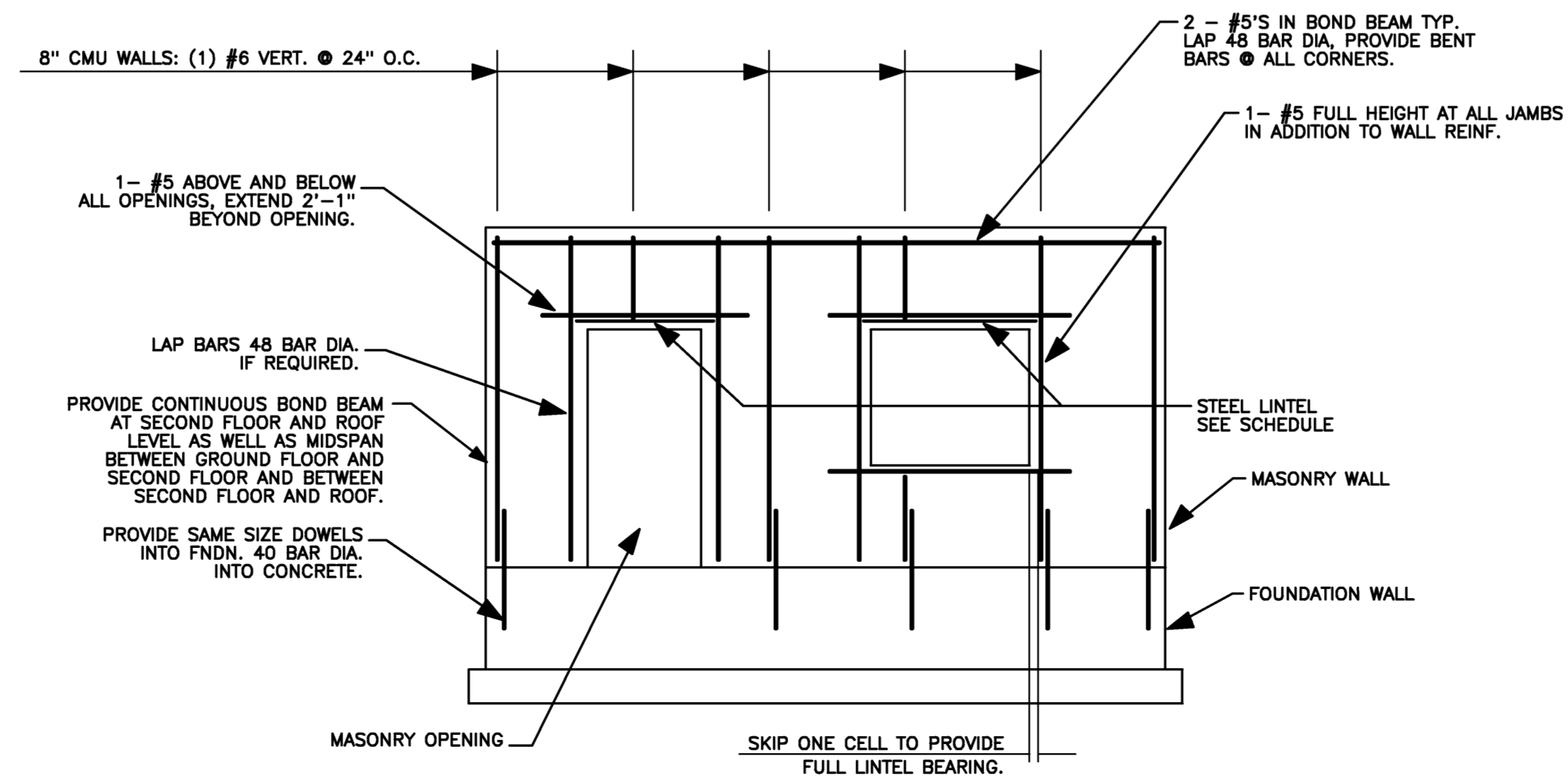

A2 TYPICAL MASONRY REINFORCING
 NO SCALE REF: NA

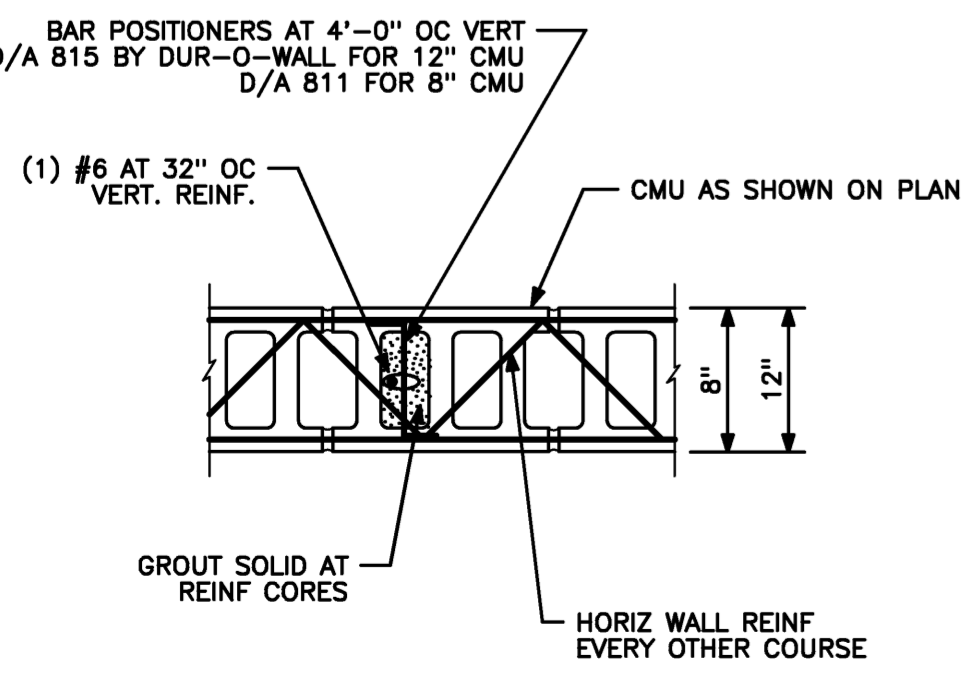

A4 TYPICAL MASONRY REINFORCING PLAN
 NO SCALE REF: NA

Mark	Date	Description
-	05-15-06	ISSUED FOR CONSTRUCTION
-	03-14-06	FINAL REVIEW
-	02-03-06	DD REVIEW

Issue Dates

Drawing Status

Drawing Title

STRUCTURAL DETAILS

PA / PE: JCF Drawn By: SJF

Drawing Number

S60.2