

③ UPPER CABINET DETAIL
1" = 1'-0"

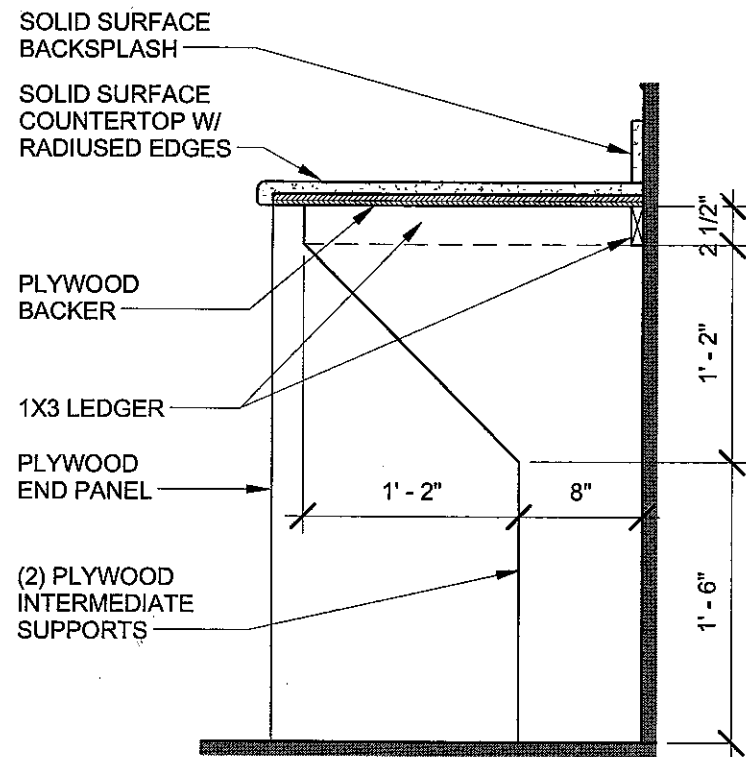

ALTERNATE #1:
COUNTERTOP - CONCRETE W/ CRUSHED GLASS

② COUNTERTOP
1" = 1'-0"

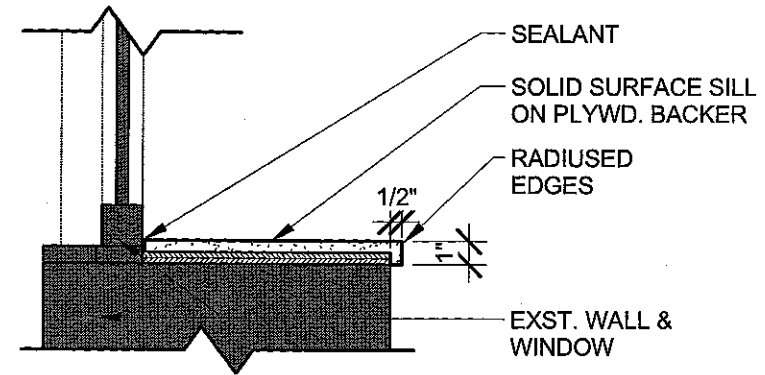

④ WINDOW SILL DETAIL
1 1/2" = 1'-0"

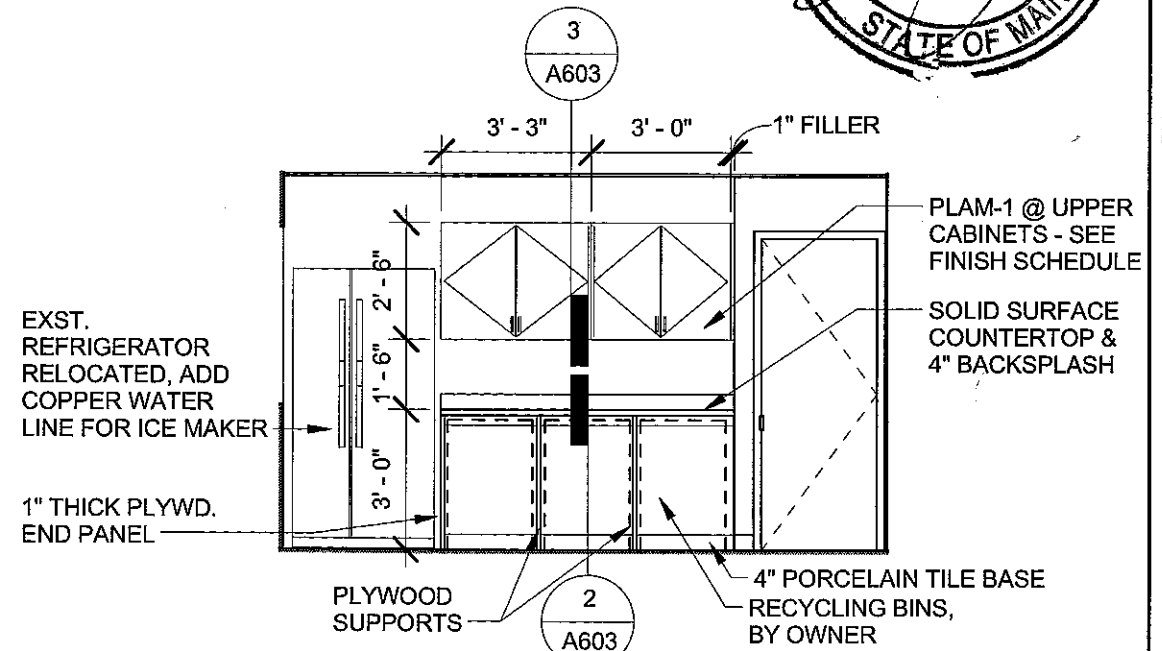
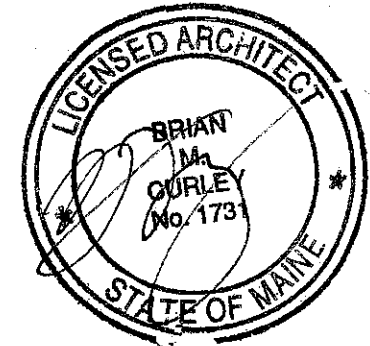

① ELEVATION - BREAK ROOM
1/4" = 1'-0"

Ecomaine - Renovation of Office/Break Area
64 Blueberry Road, Portland, ME 04102

SHEET
A603

JOB # 12122
DATE 05/08/13
SCALE As indicated

TITLE
DETAILS

© 2012 PDT Architects

ARCHITECTURE
INTERIOR DESIGN
PLANNING

49 DARTMOUTH STREET
PORTLAND, MAINE 04101
www.pdtarchs.com

