

GENERAL NOTES:

1. SEE G1001 FOR PROJECT GENERAL NOTES.

**SM
RT**

ARCHITECTURE ENGINEERING PLANNING
SMART

144 Fore Street/P.O. Box 618
Portland, Maine 04104
tel. (207) 772-3846
fax. (207) 772-1070

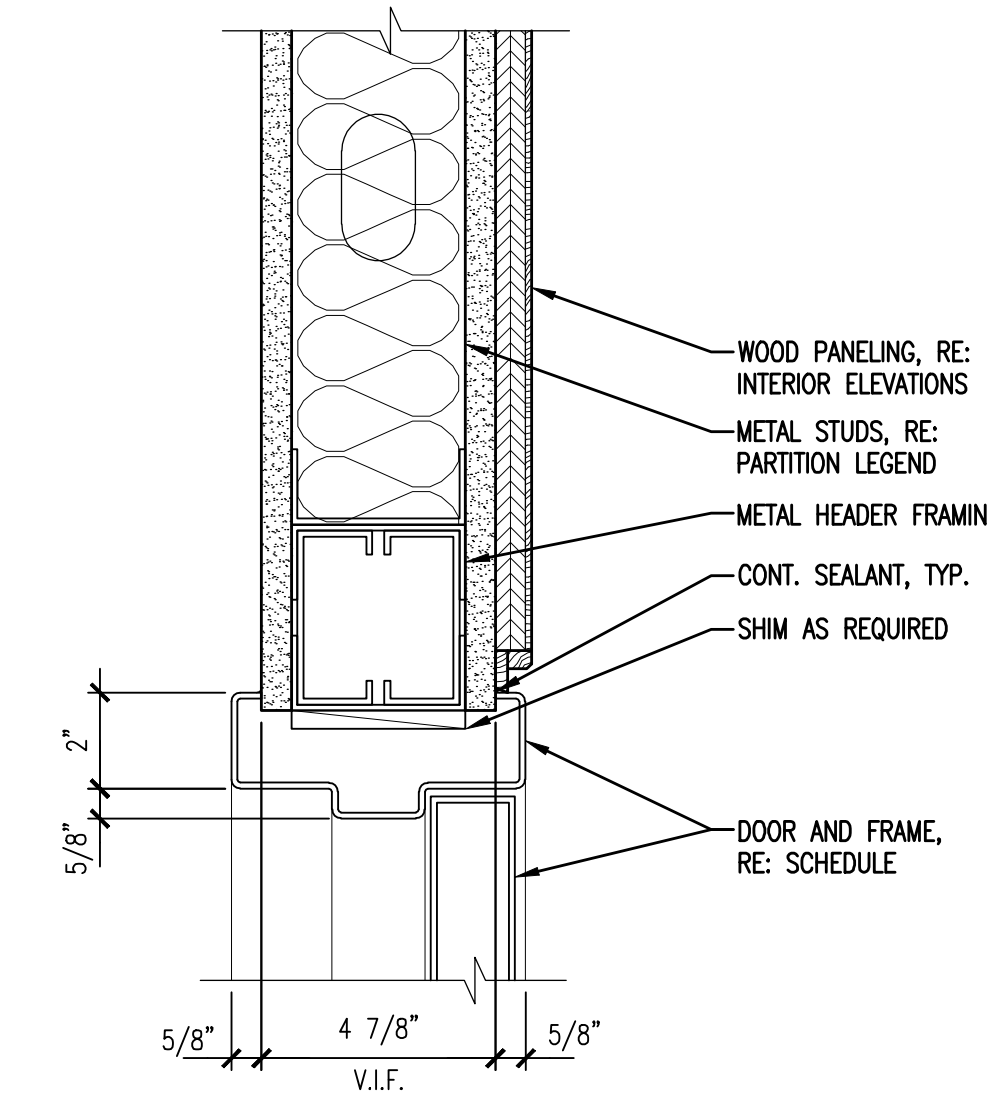
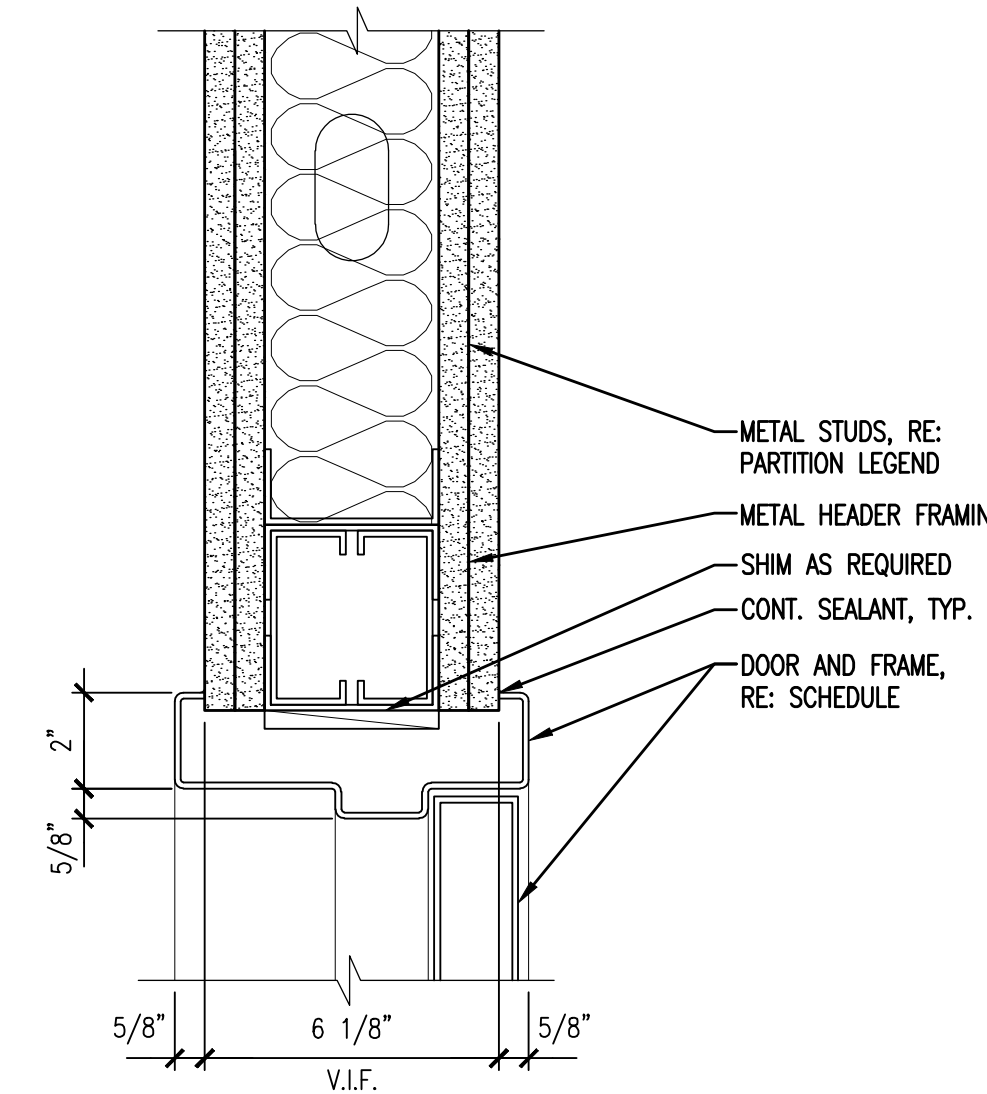
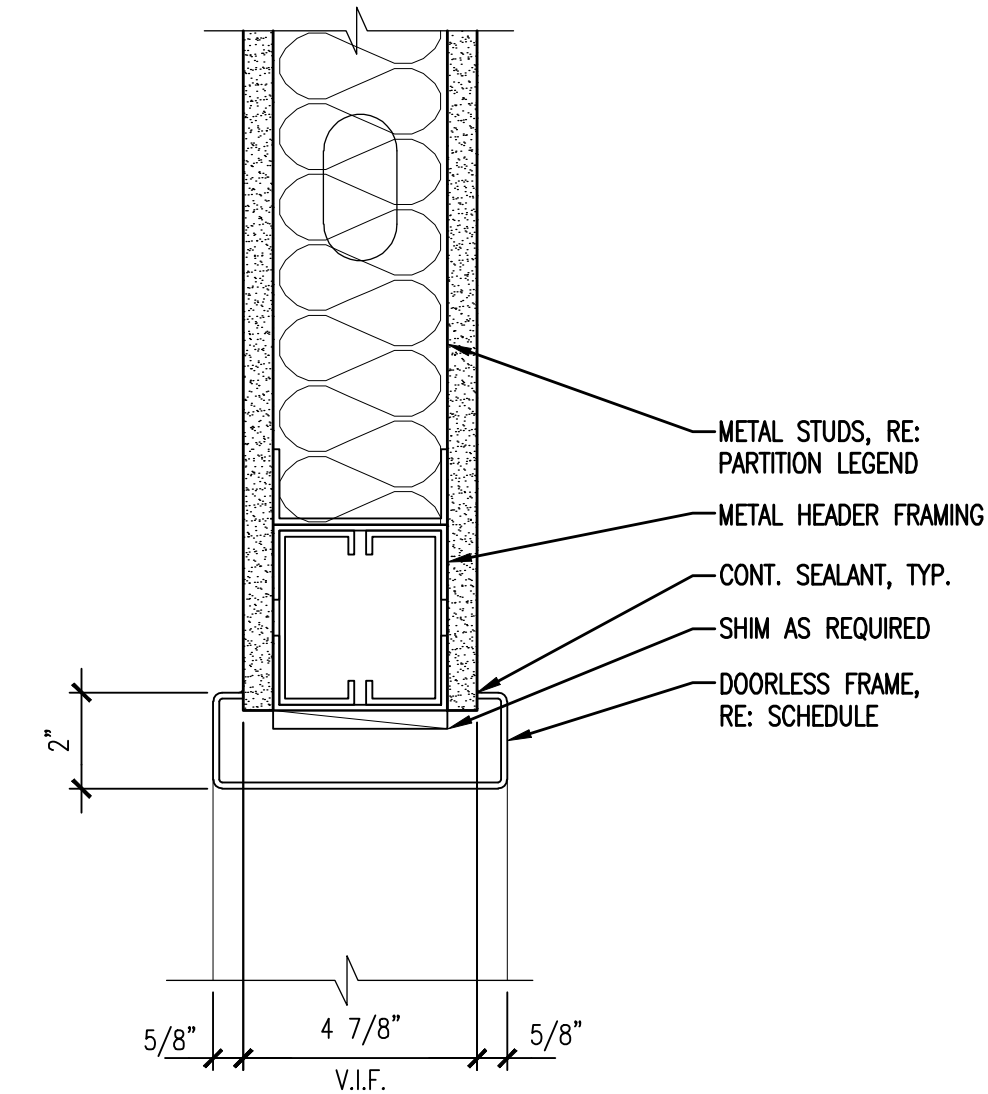
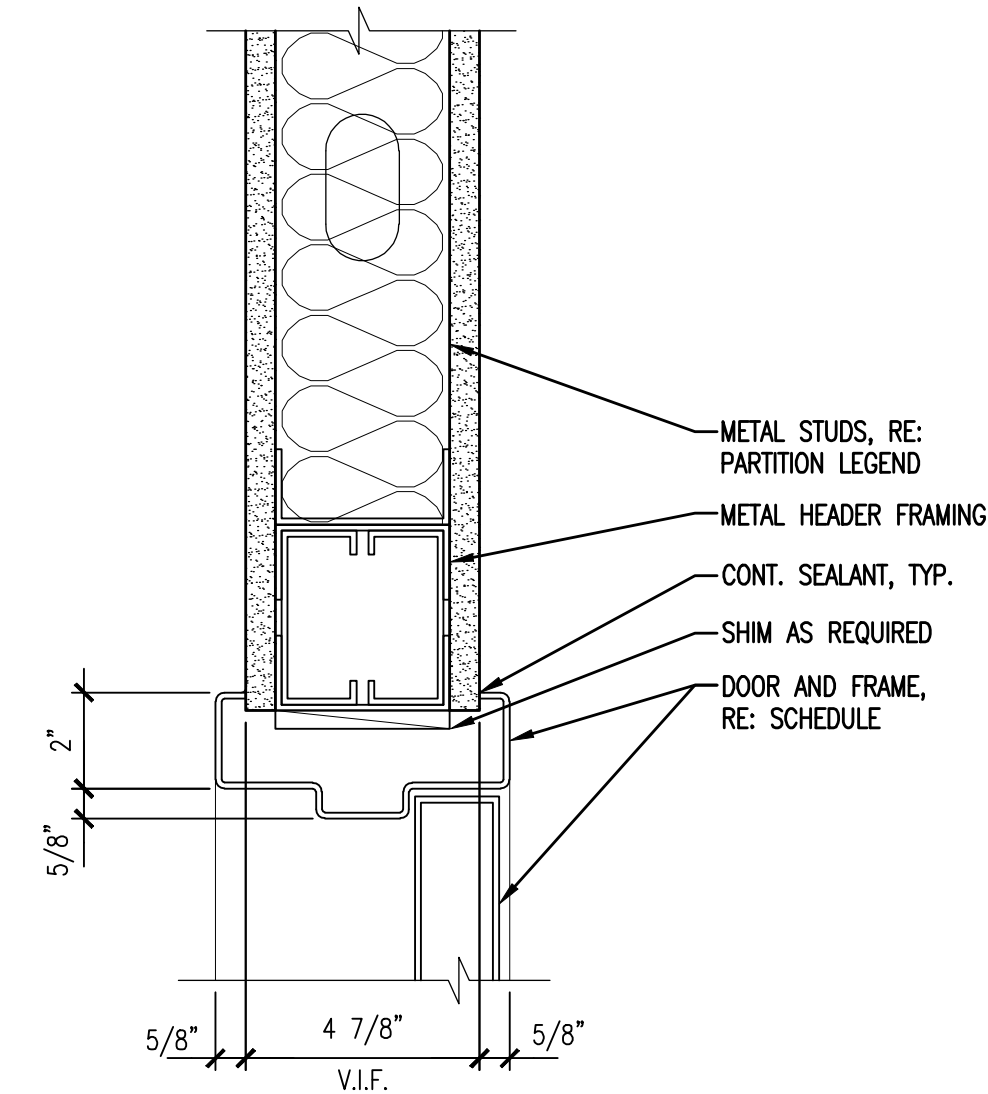

J1 HEAD DETAIL

J4 HEAD DETAIL

J7 HEAD DETAIL

J10 HEAD DETAIL

3" = 1'-0"

3" = 1'-0"

3" = 1'-0"

3" = 1'-0"

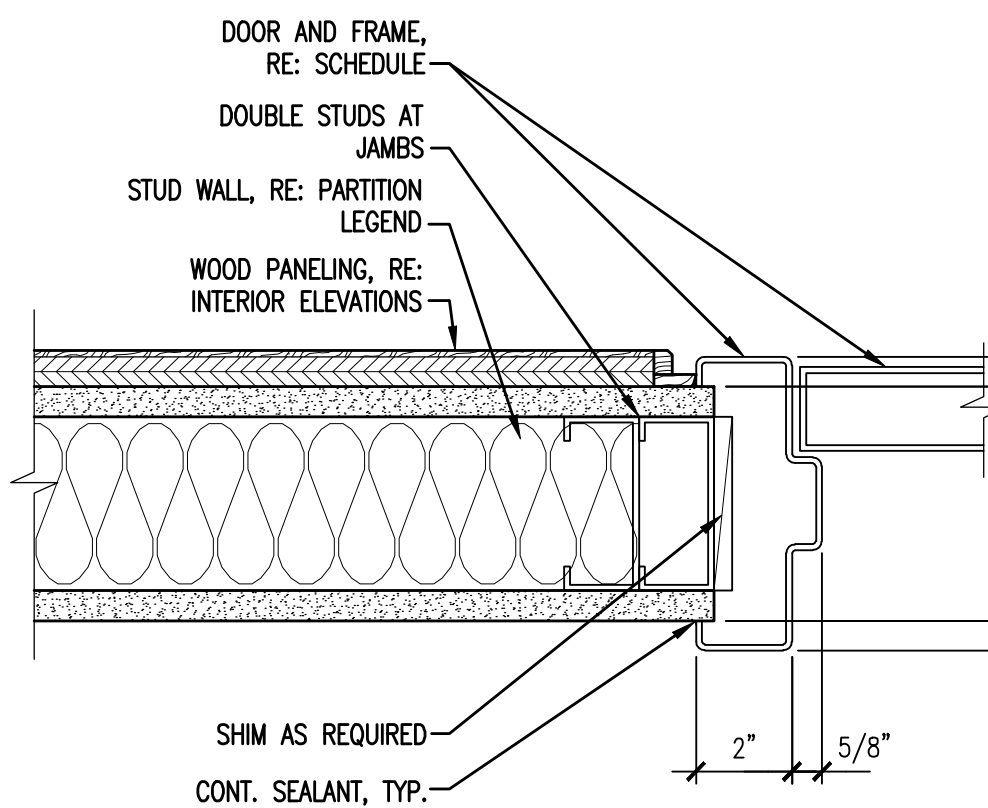
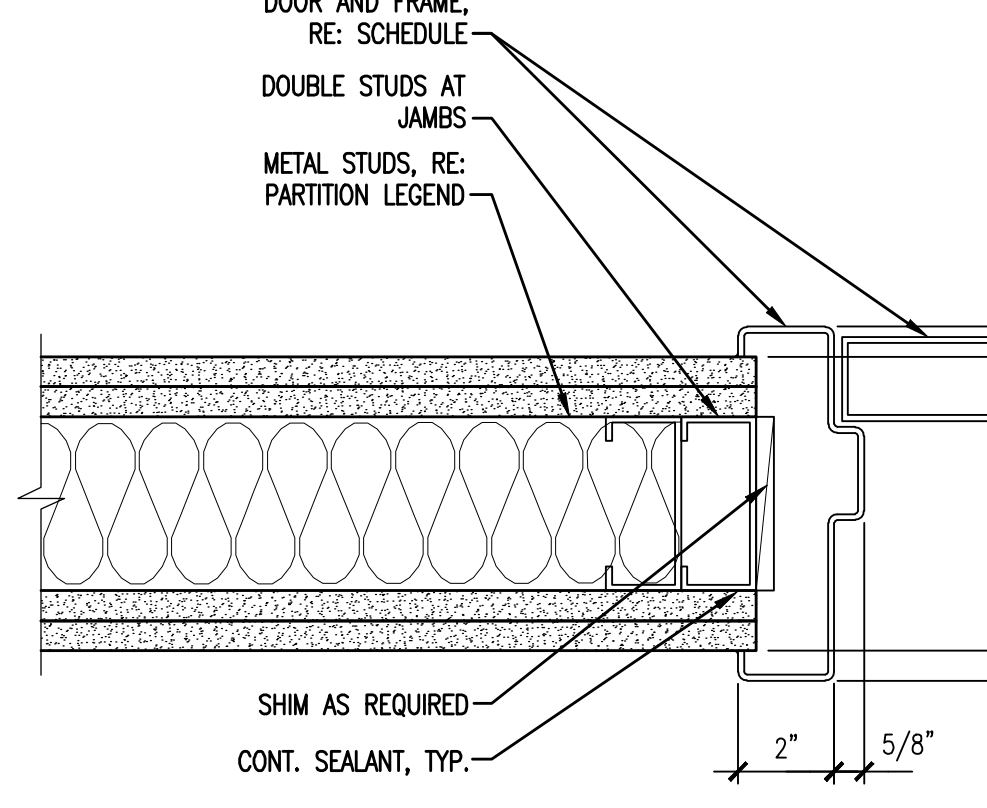
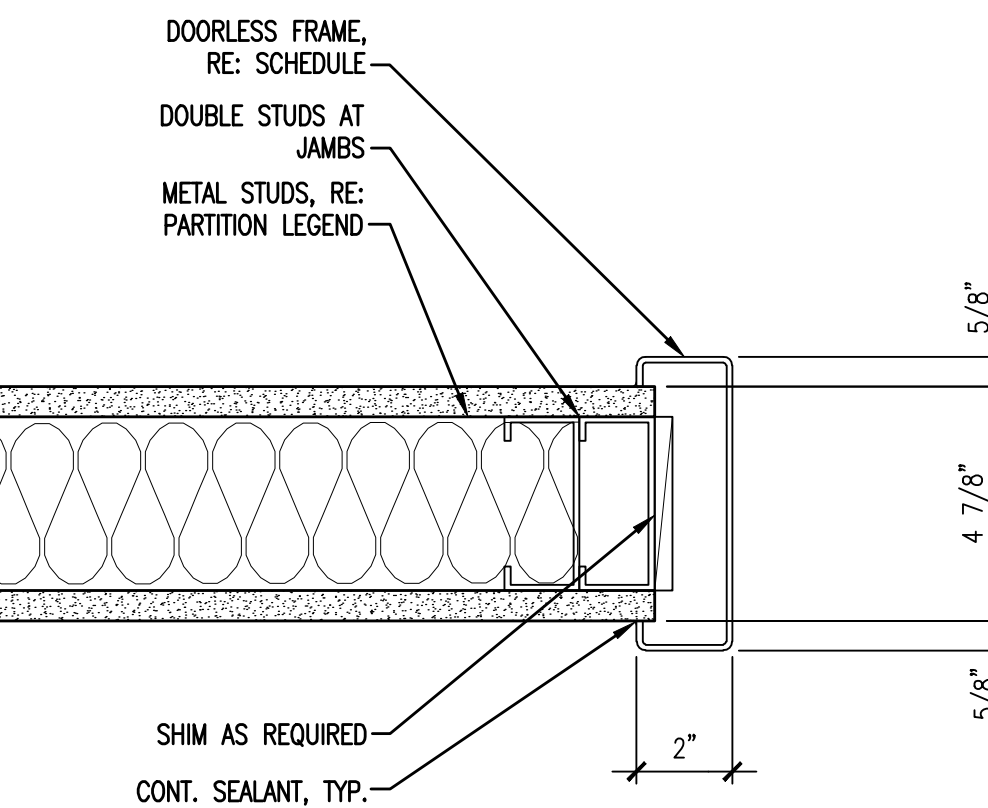
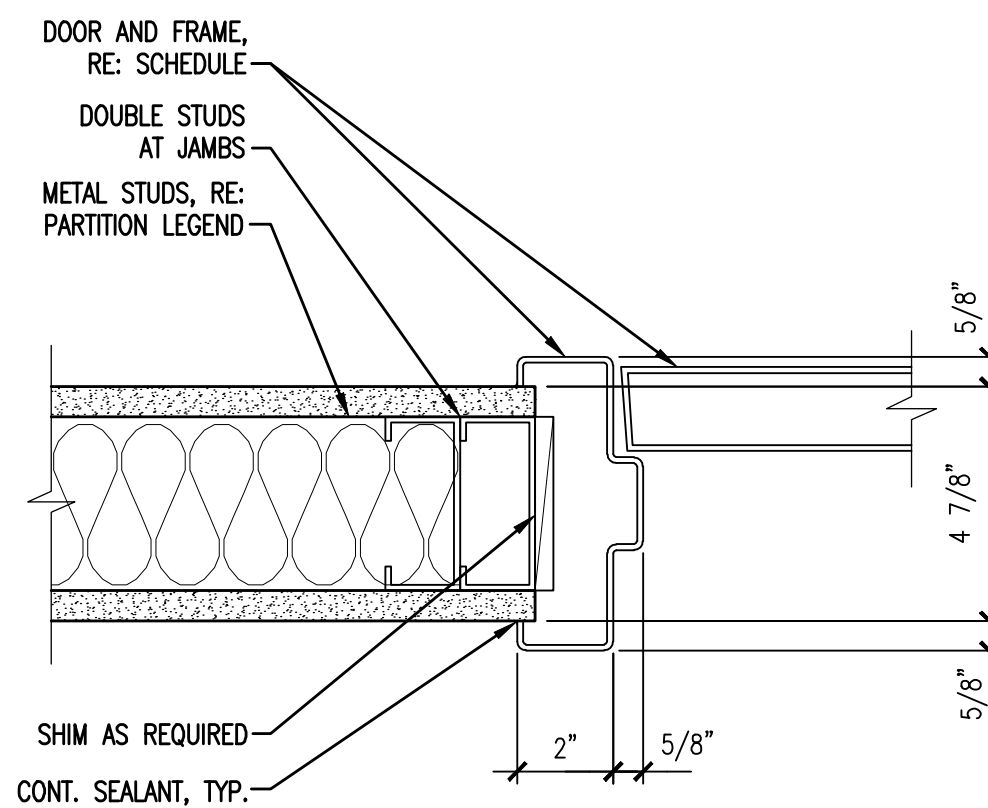

E1 JAMB DETAIL

E4 JAMB DETAIL

E7 JAMB DETAIL

E10 JAMB DETAIL

3" = 1'-0"

3" = 1'-0"

3" = 1'-0"

3" = 1'-0"

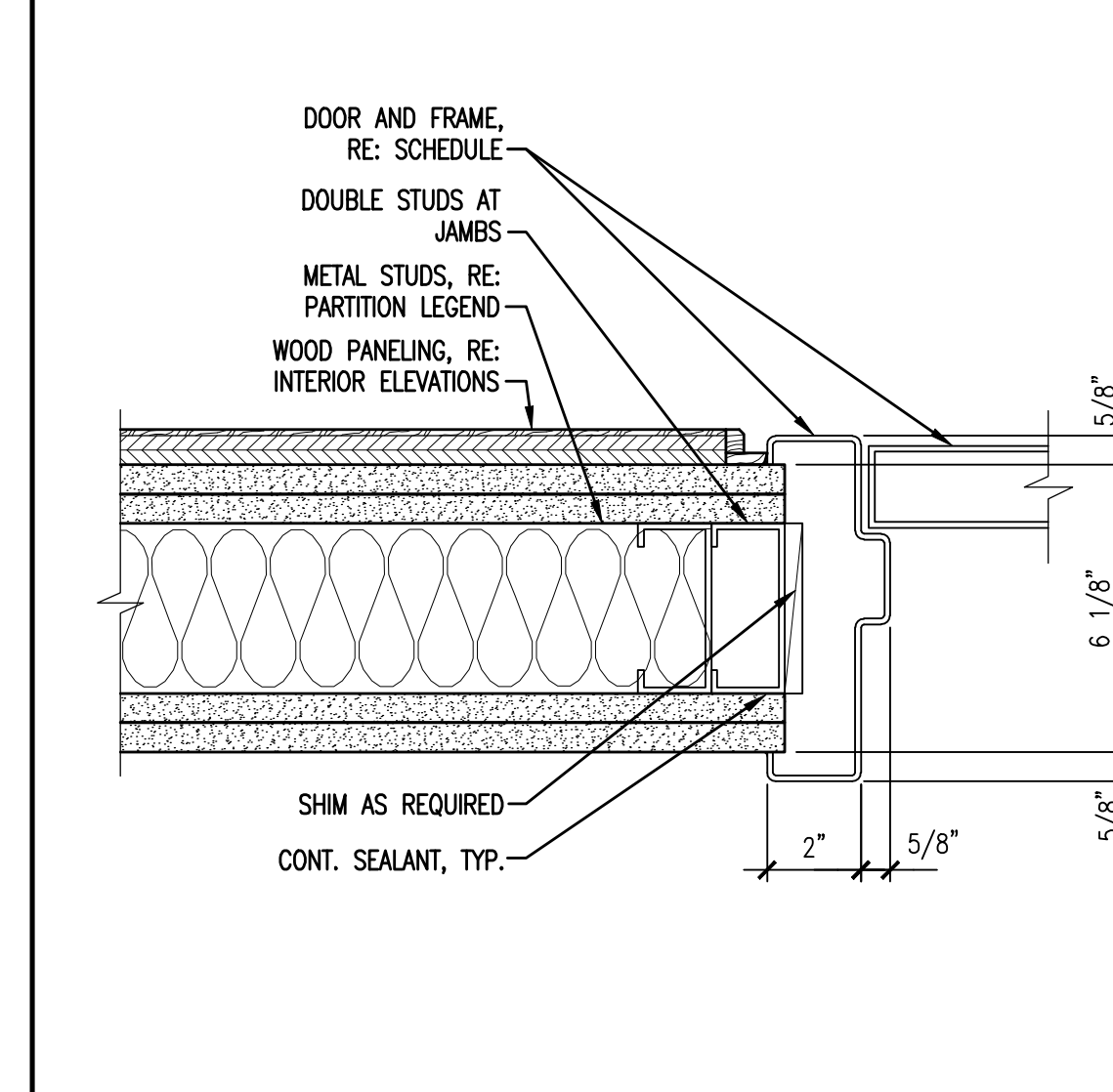
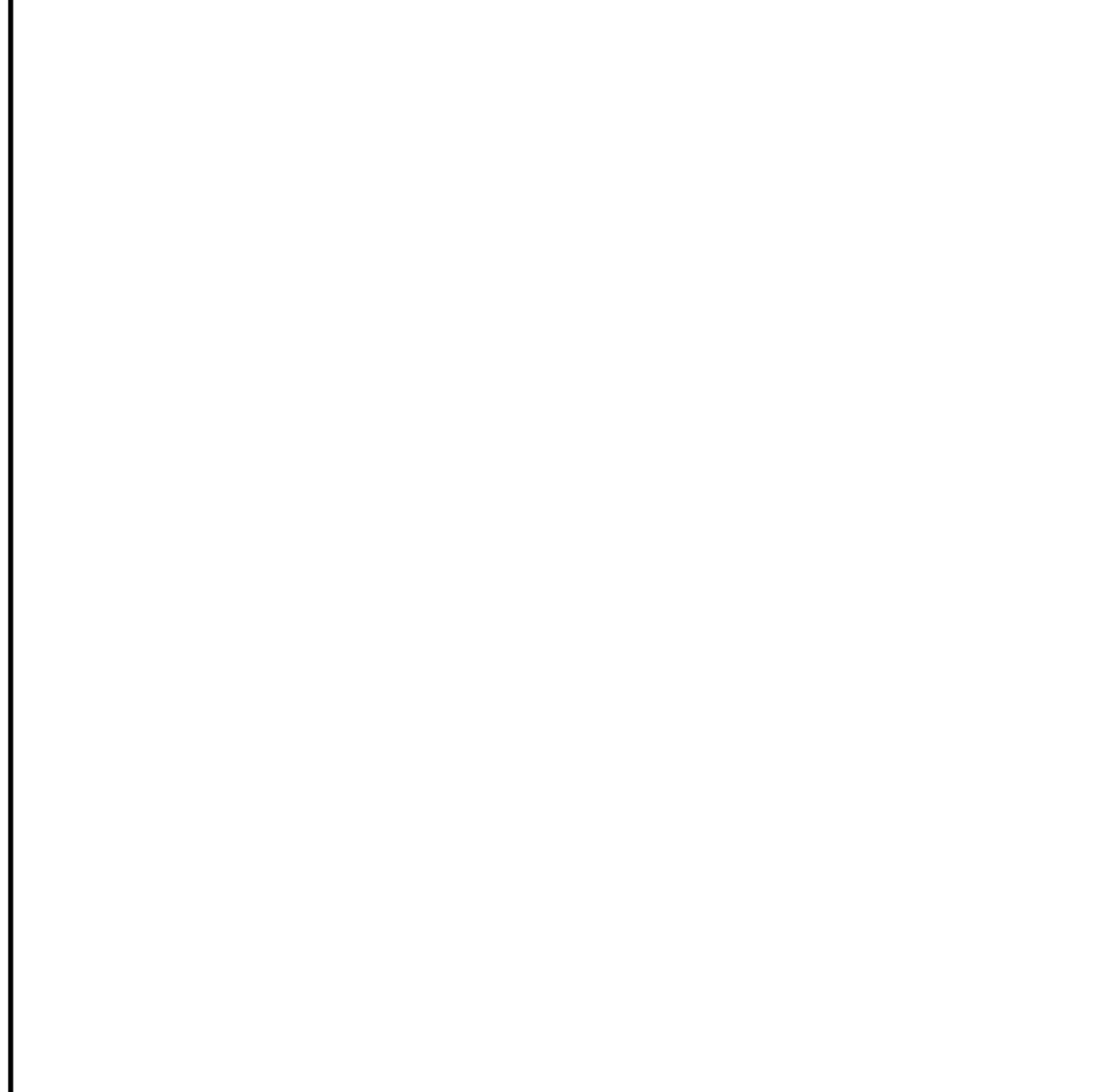
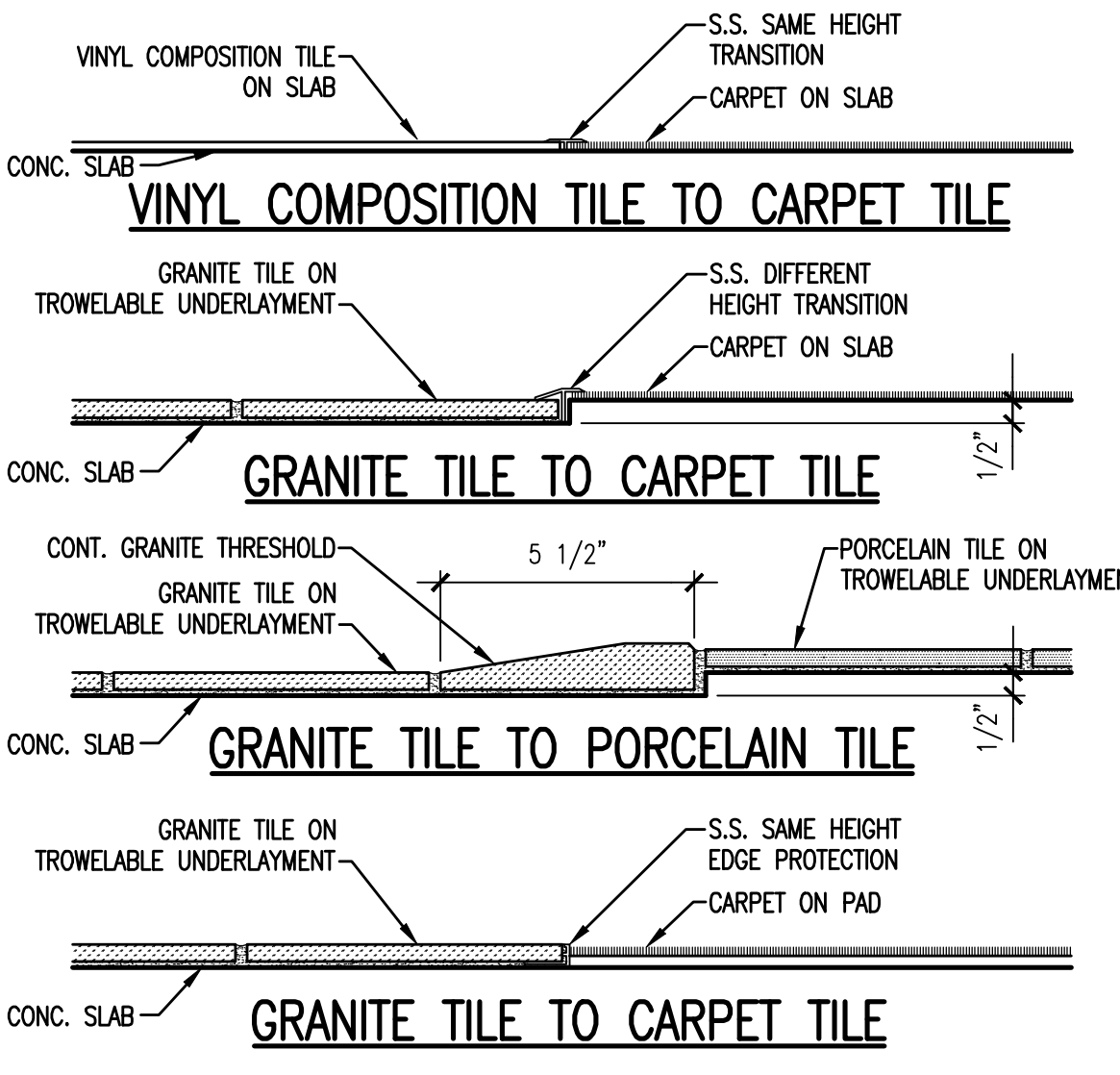

A1 FLOOR MATERIAL TRANSITIONS

A4

A7

A10 JAMB DETAIL

3" = 1'-0"

*

*

3" = 1'-0"

PROJECT TITLE:
**MAINE TURNPIKE AUTHORITY
ADMINISTRATION BUILDING**
PORTLAND, MAINE

CURRENT ISSUE STATUS:
ISSUED FOR BIDDING/CONSTRUCTION
7-9-07

REV	DESCRIPTION	DATE
0	BIDDING/CONSTRUCTION	7-9-07

GRAPHIC SCALE:
0" 1"

SCALE: AS NOTED
PROJECT MANAGER: SLB
JC/DRAWN BY: TCM/TCM
A/E OF RECORD: SLB
CAD FILE: AE623-06016
PROJECT NO: 06016
DATE: 7-9-07

SHEET TITLE:
**DOOR & WINDOW
DETAILS**

SHEET No.
AE623
© COPYRIGHT 2007 SMART