

**D-5 FLOOR-MOUNTED CHAIR OUTLET**  
NOT TO SCALE

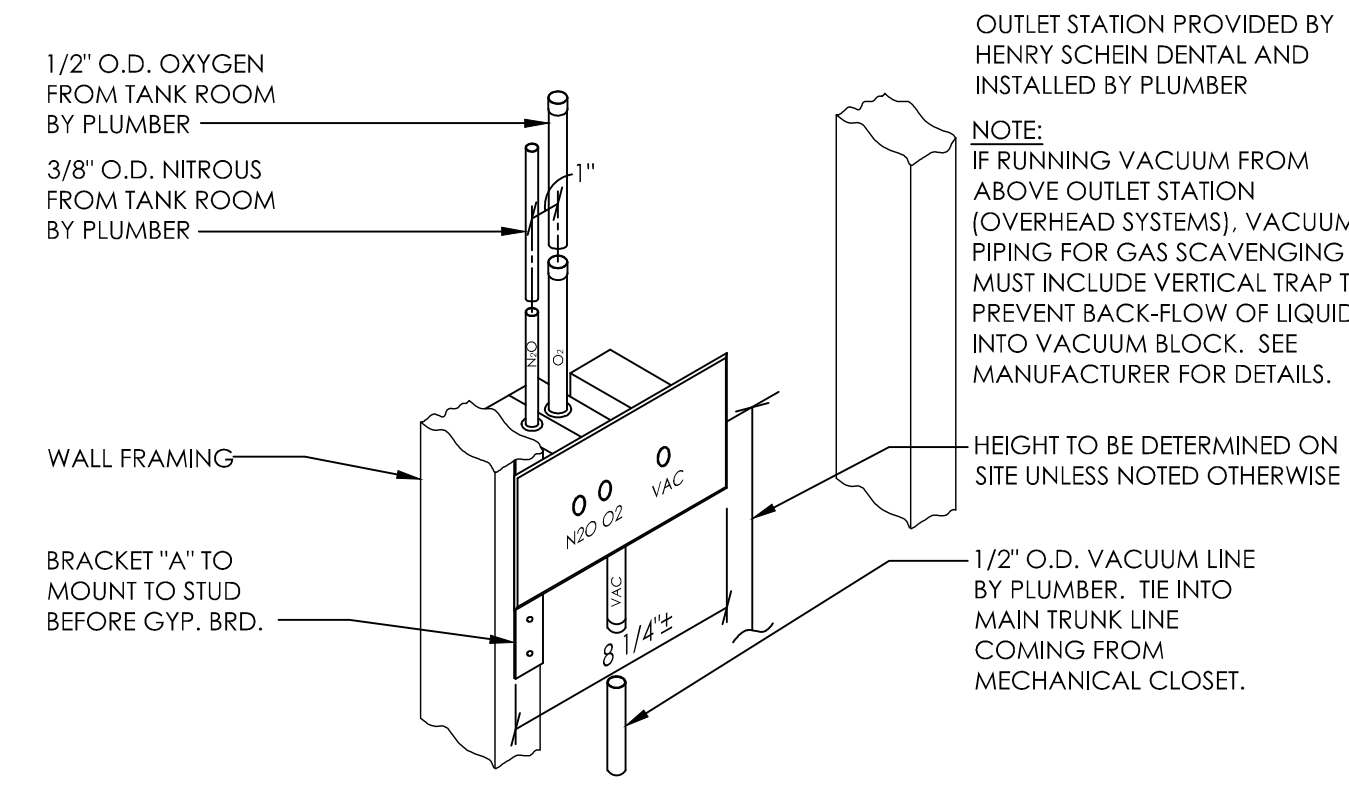

**D-7 N<sub>2</sub>O, O<sub>2</sub> AND VACUUM OUTLET STATION**  
NOT TO SCALE

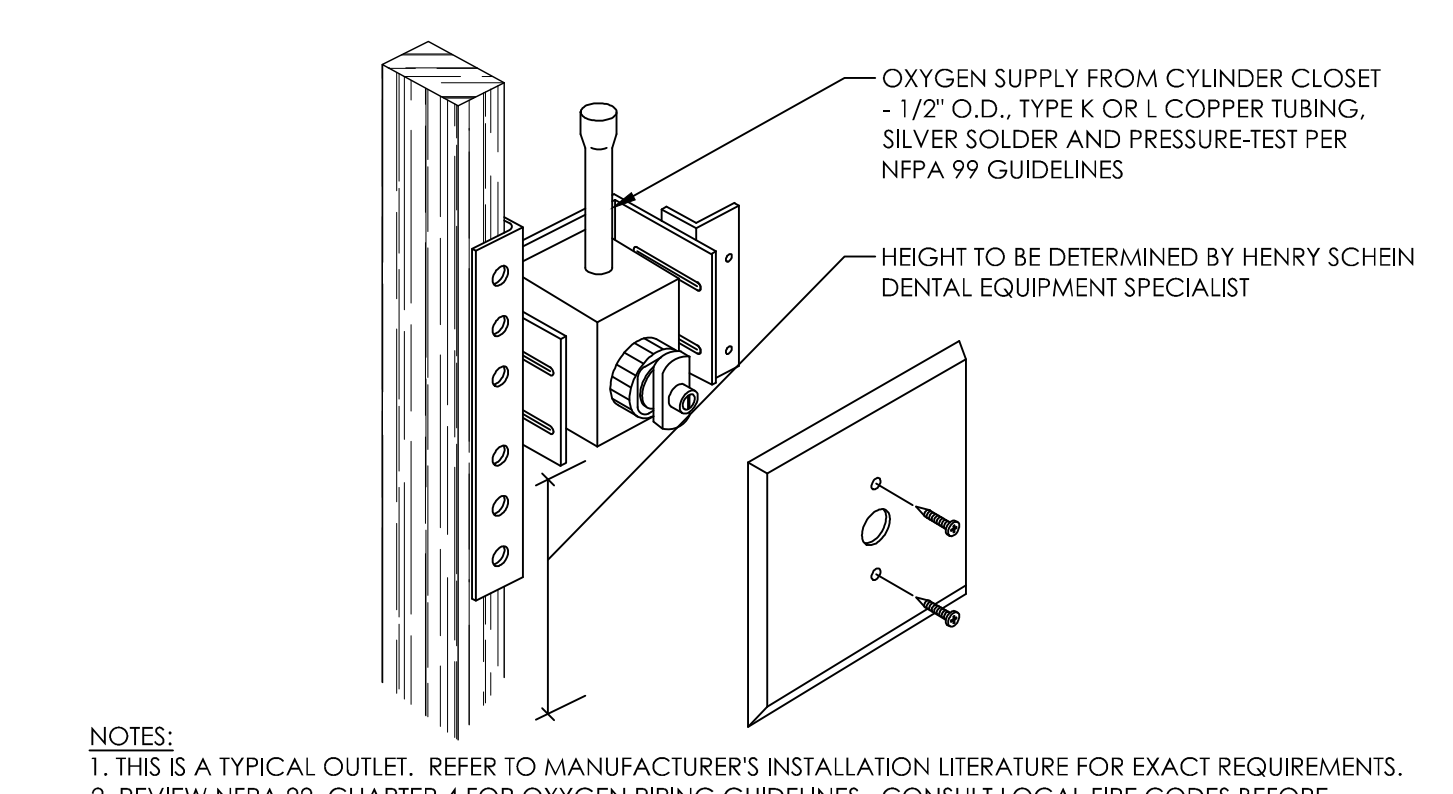

**D-7A OXYGEN OUTLET**  
NOT TO SCALE

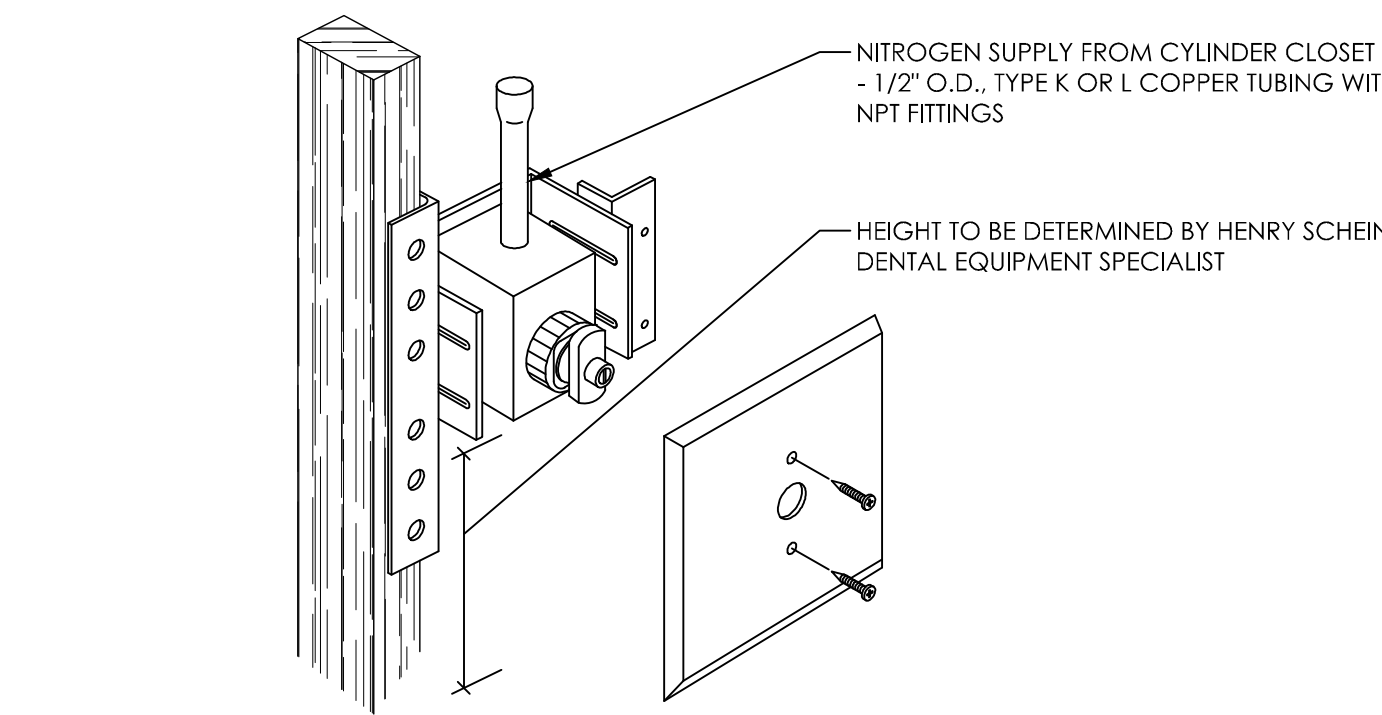

NOTES:  
1. THIS IS A TYPICAL OUTLET. REFER TO MANUFACTURER'S INSTALLATION LITERATURE FOR EXACT REQUIREMENTS.  
2. CONSULT LOCAL FIRE AND PLUMBING CODES BEFORE INSTALLATION.

**D-7B NITROGEN OUTLET**  
NOT TO SCALE

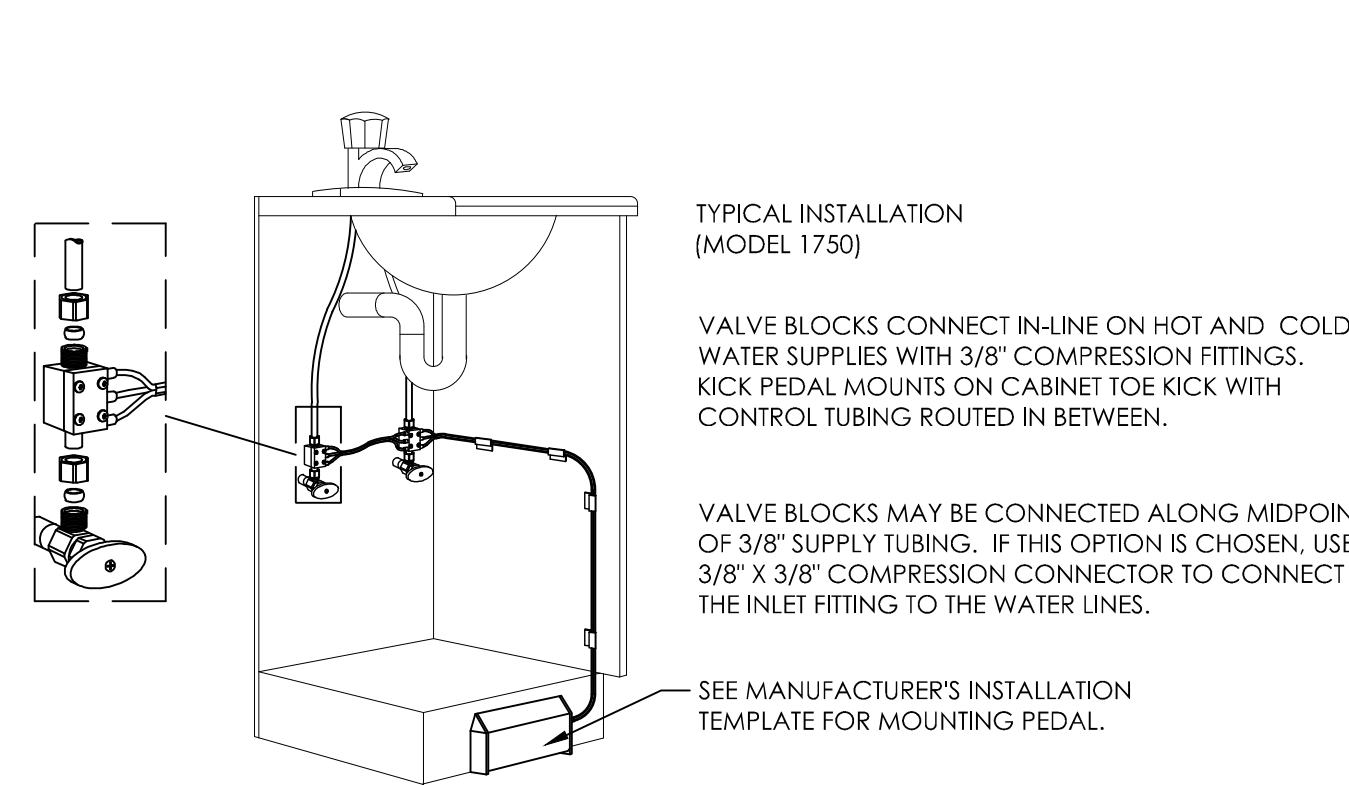

**D-12B TAPMASTER FAUCET CONTROL**  
NOT TO SCALE

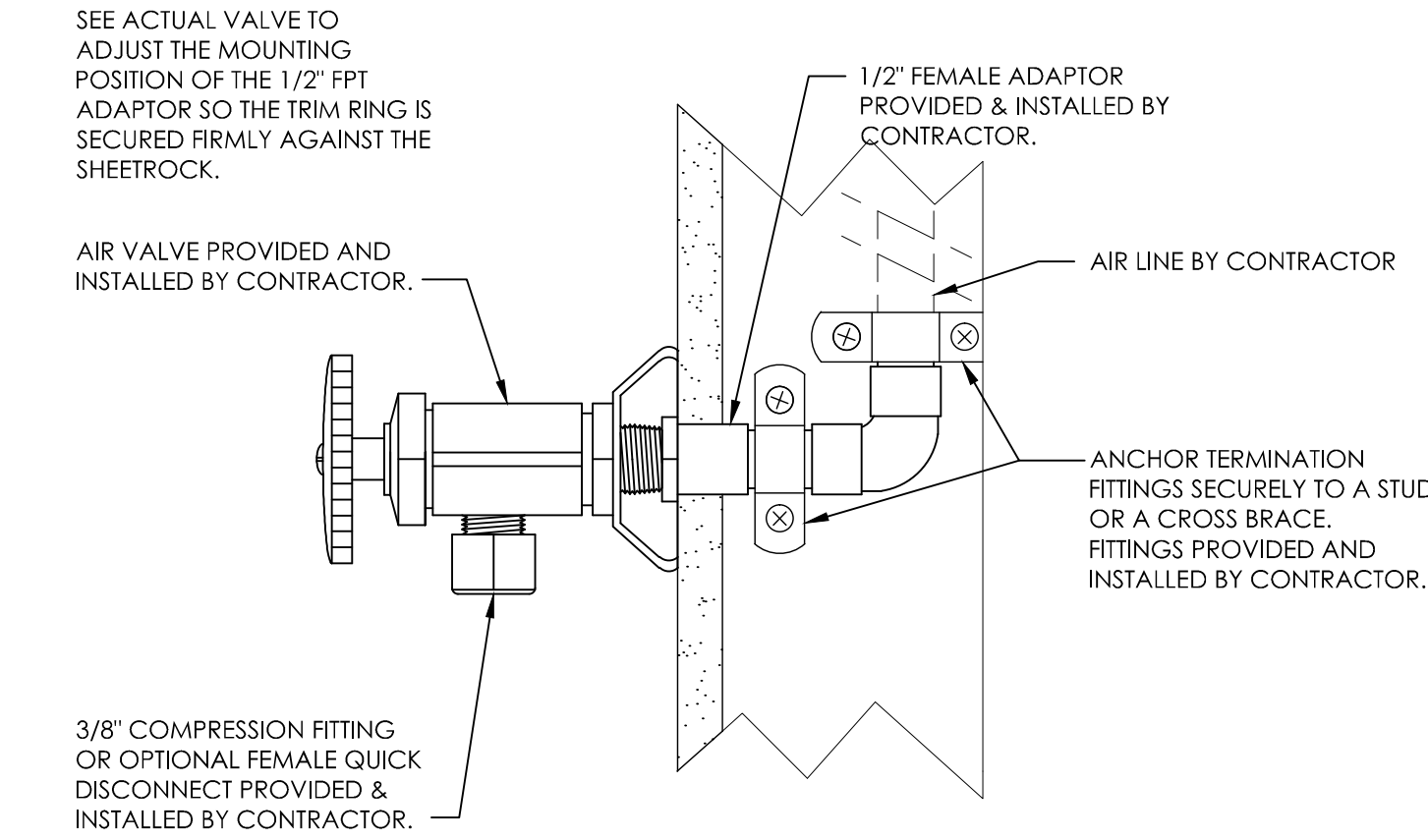

**D-13 AIR VALVE**  
NOT TO SCALE

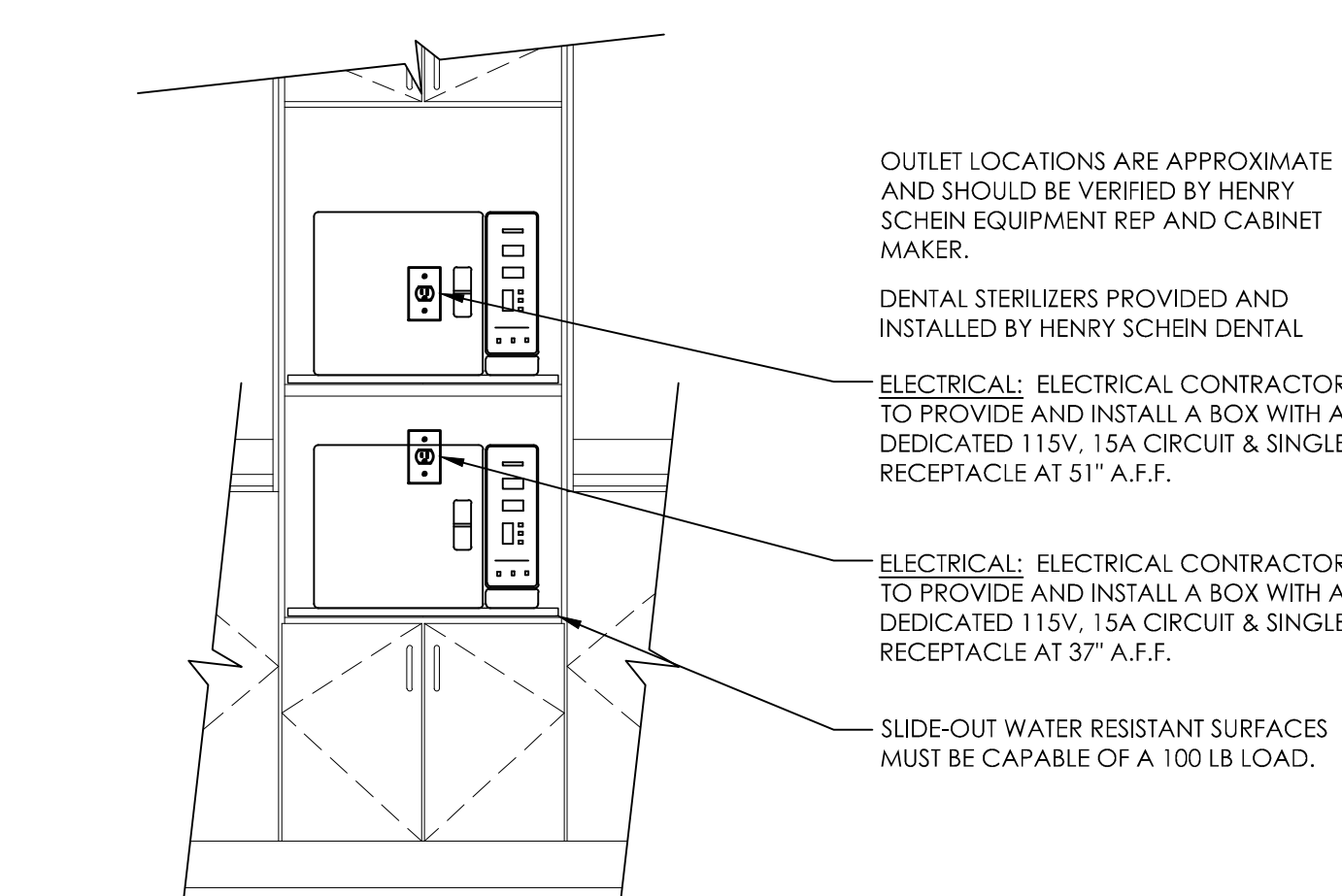

**D-14A STACKED STERILIZERS (AUTOCLAVES)**  
NOT TO SCALE

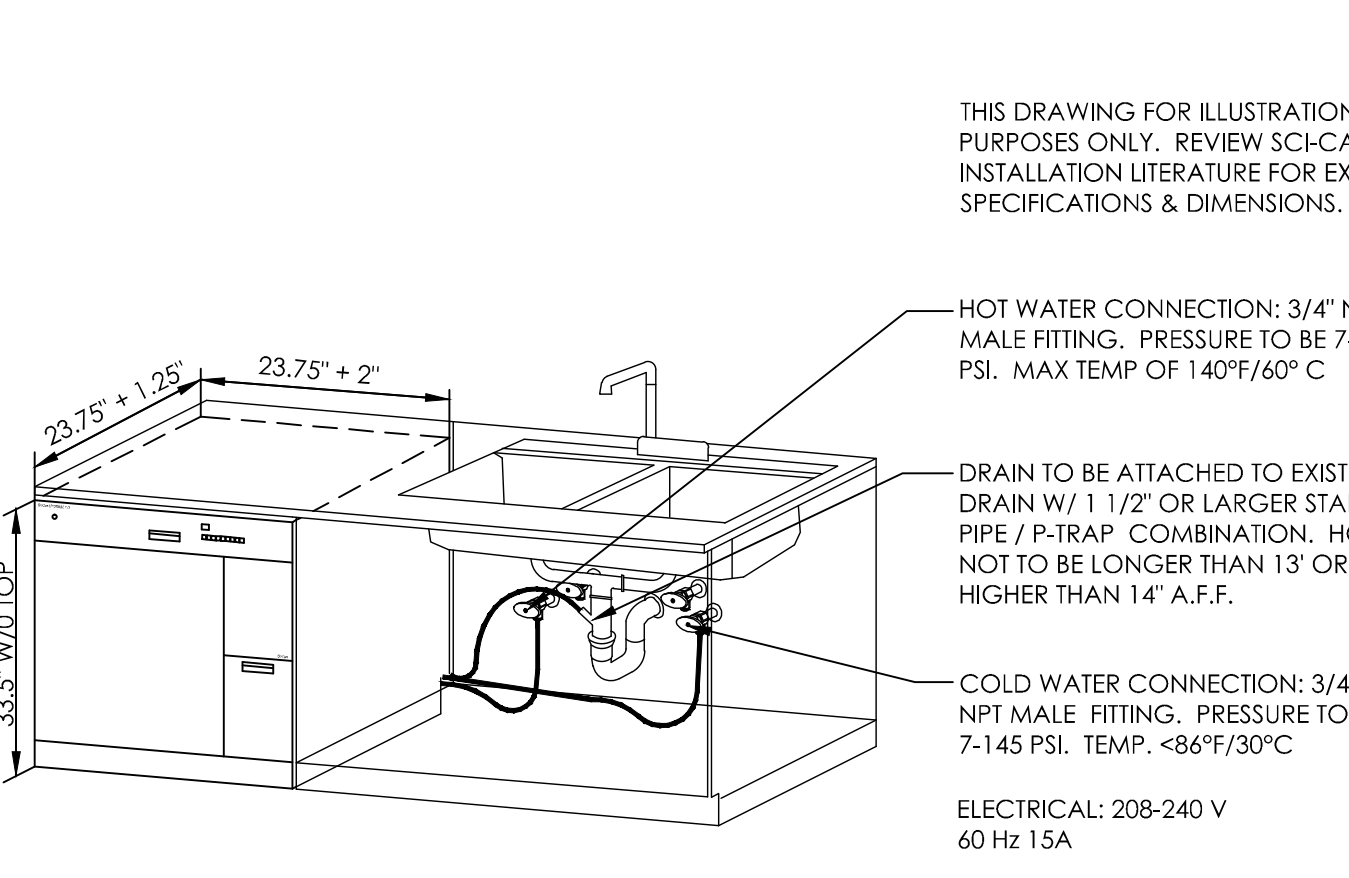

**D-15A HYDRIM INSTRUMENT WASHER**  
NOT TO SCALE

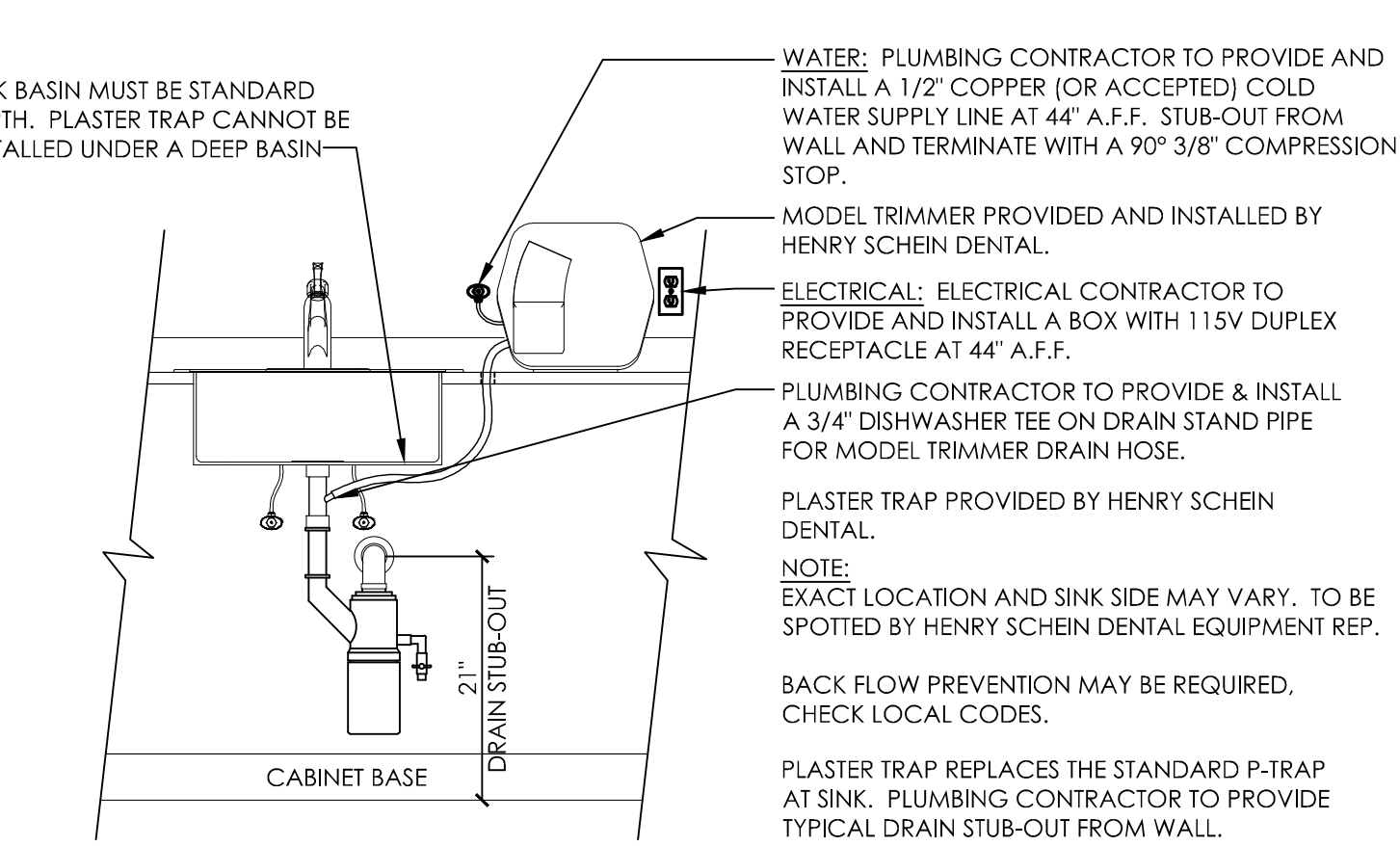

**D-16 MODEL TRIMMER & GLECO PLASTER TRAP**  
NOT TO SCALE

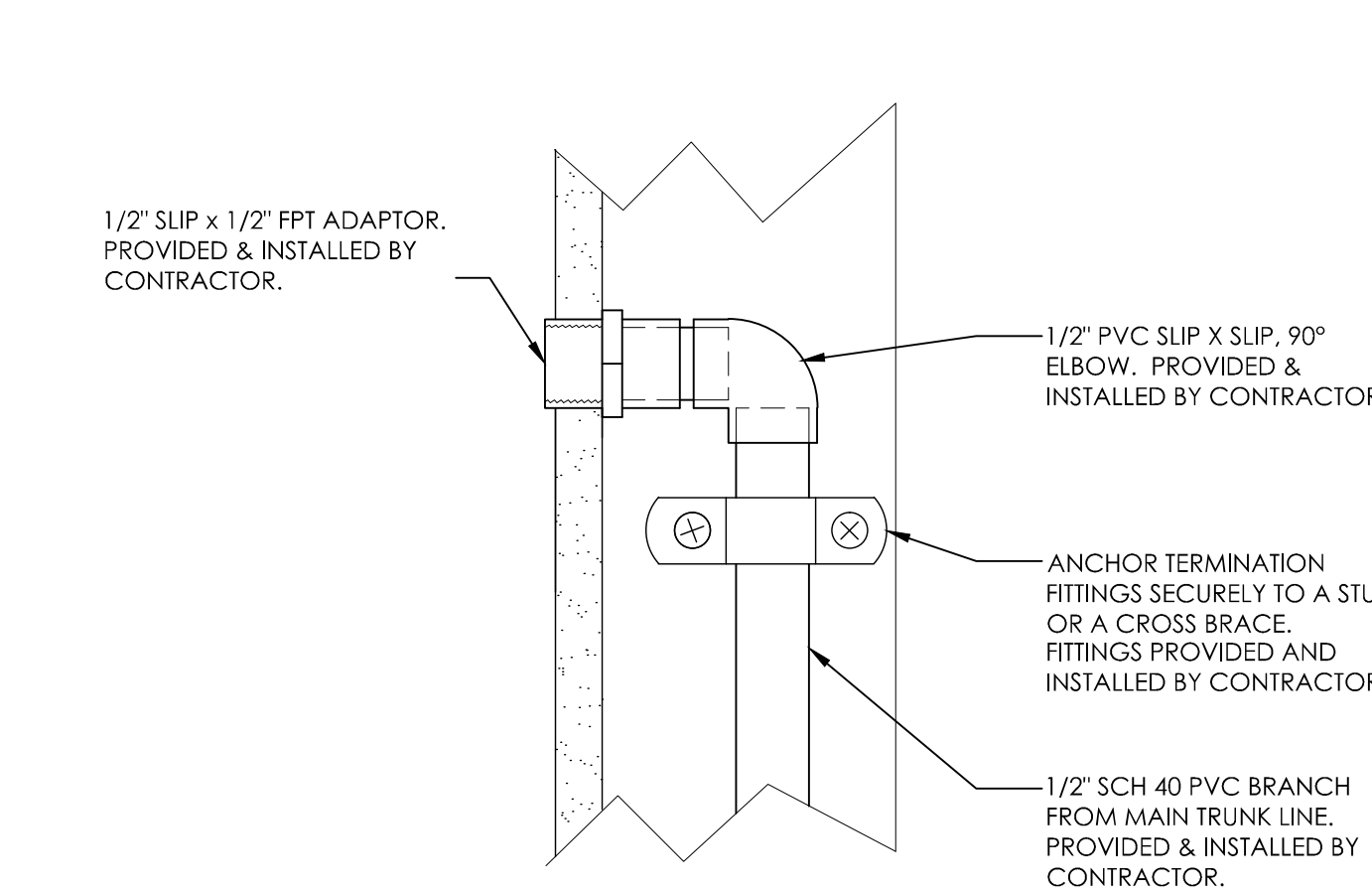

**D-28 VACUUM WALL OUTLET**  
NOT TO SCALE

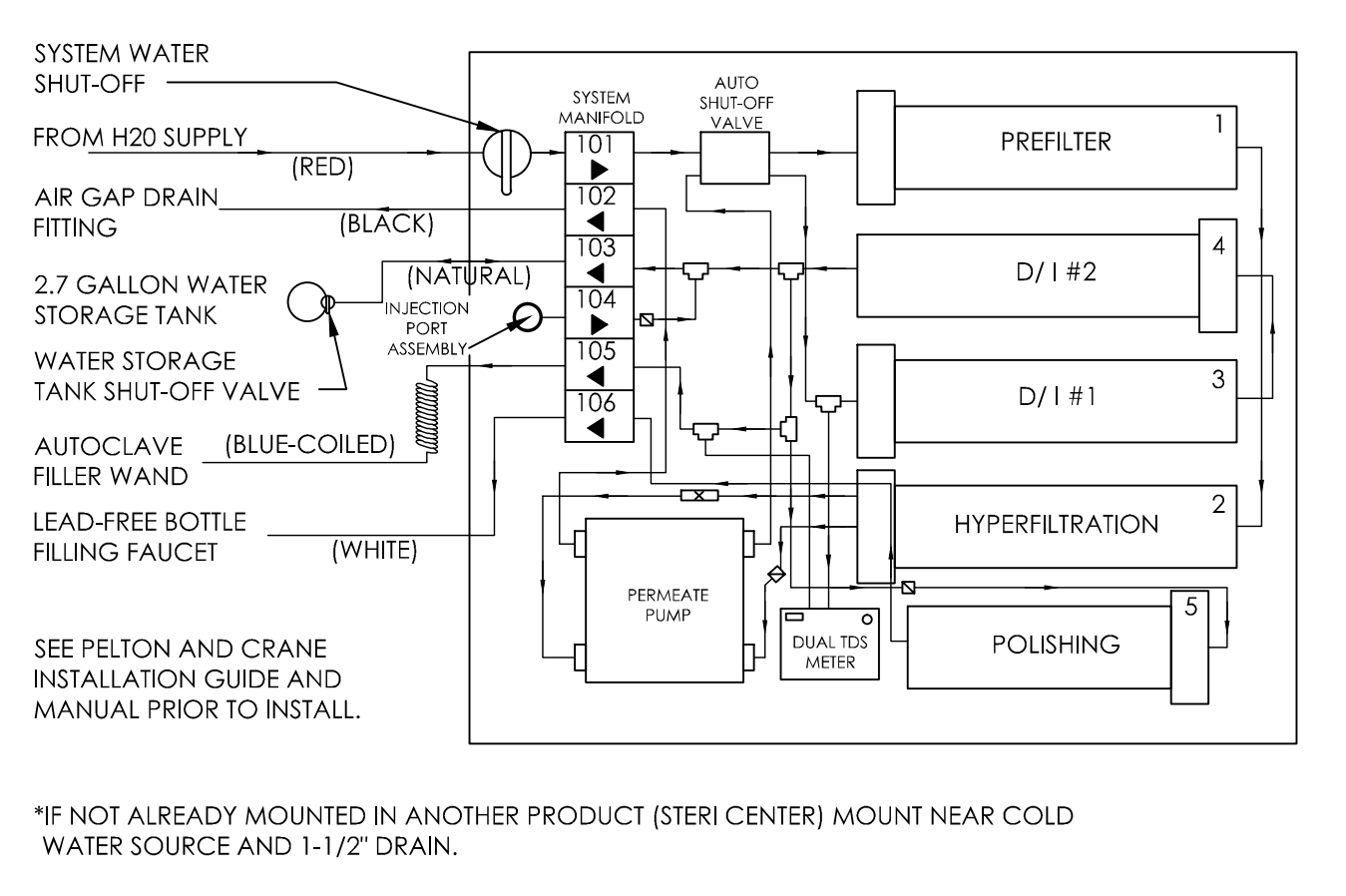

**D-30C PELTON & CRANE VISTAPURE**  
NOT TO SCALE

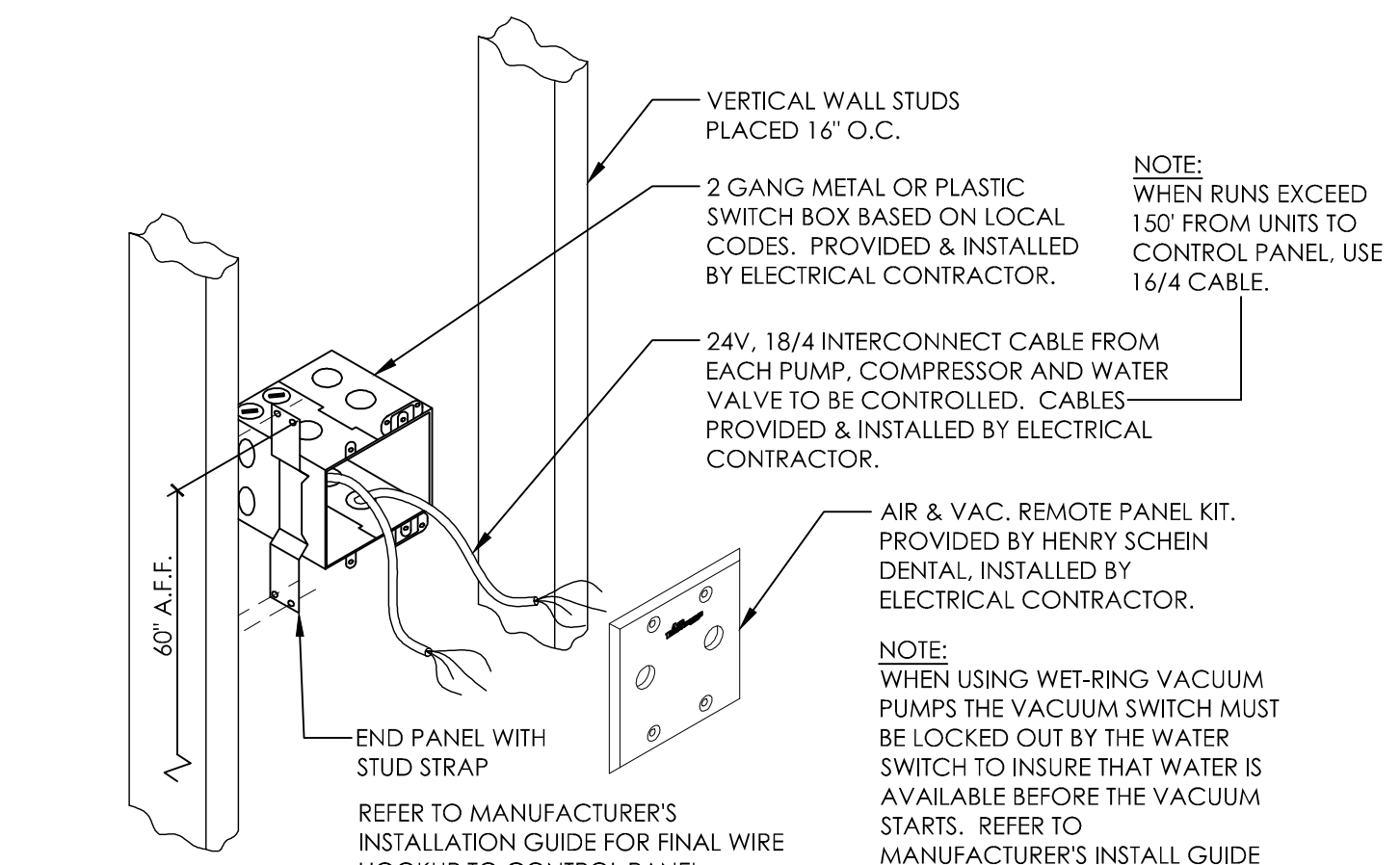

**D-32B AIRTECH CONTROL PANEL (2 SWITCH)**  
NOT TO SCALE

**HENRY SCHEIN®**  
DENTAL  
10920 WEST LINCOLN AVENUE  
WEST ALLIS, WI 53227

PROJECT:  
**SOUTHERN MAINE ORAL SURGERY**  
LOCATION:  
131 JOHNSON ROAD  
PORTLAND, ME 04102

HENRY SCHEIN REP:  
JESSE LEVEILLE  
CENTER:  
BOSTON, MA  
PHONE #:  
(207) 233-4978

**IMPORTANT NOTE:**  
THIS DOCUMENT HAS BEEN PREPARED AS AN INSTRUMENT OF PROFESSIONAL SERVICE, AND IS NOT AN ARCHITECTURAL PLAN. IDEAS/DESIGNS INCLUDED HEREIN ARE THE SOLE PROPERTY OF HENRY SCHEIN DENTAL, AND ARE PROTECTED UNDER COPYRIGHT. THEY MAY NOT BE USED OR REPRODUCED WITHOUT EXPRESSED WRITTEN CONSENT OF HENRY SCHEIN AND FULL PAYMENT OF ANY ASSOCIATED DESIGN FEES.  
**ALL DIMENSIONS ARE SUBJECT TO JOB-SITE VERIFICATION.**

DRAWING NAME:  
SMOS-1c-D  
PROJECT START DATE:  
08/11/2014  
FINALS START DATE:  
08/20/2014  
DRAWN BY: AKL/CAS  
CHECKED BY: AKL/TJK

REVISIONS:  
10/24/14 AKL  
INT.SQ.FT. = 3992

SCALE: SH. SIZE:  
SEE DTL. D  
**MECHANICAL**  
DETAILS

**SPE.1**