

ALL EXISTING WINDOWS REPLACED WITH DOUBLE GLAZED CASEMENT UNITS UNLESS OTHERWISE INDICATED

NEW DORMER BEYOND

NEW WINDOWS

NEW METAL ROOFING, TYP.
NEW PORCH
ROOF EXTENSION

NEW PAINTED WOOD SHINGLES
AND TRIM

NEW PORCH ENCLOSURE.
PROVIDE NEW CASEMENT
WINDOWS AS SHOWN.

EXIST. FIRST FLOOR LINE

APPROX. EXIST. GRADE

2'-0"

12

12

5.44

5

8'-0"

12

12

12

EXTEND EXIST.
MAS. CHIMNEY AS REQ'D.
BY NEW ROOF

NEW ROOF AT 12:12 SLOPE

NEW DORMER BEYOND

NOTE:
NEW BEDROOM WINDOWS TO
MEET EGRESS SIZE REQUIREMENTS.
FIT IN EXIST. OPENINGS TO MIN. SIZE
AS SHOWN

NOTE:
NEW BATHROOM WINDOWS IN
SHOWER TO BE PROVIDED WITH
CLASS II TEMPERED SAFETY GLASS

REPLACE EXST. BSMNT.
WINDOW WITH NEW
CASEMENT WINDOW
NOM. UNIT SIZE:
2'-7"x3'-7" TO MEET
EMERG. EGRESS SIZE
REQUIREMENTS

PREFAB. HIGH DENSITY
POLYETHYLENE EGRESS
WINDOW WELL EQUAL TO:
BILCO "SCAPWEL"
MODEL 4048-42
INSTALL IN STONE BED
AND BACKFILL
AS PER MFGR'S
INSTRUCTIONS

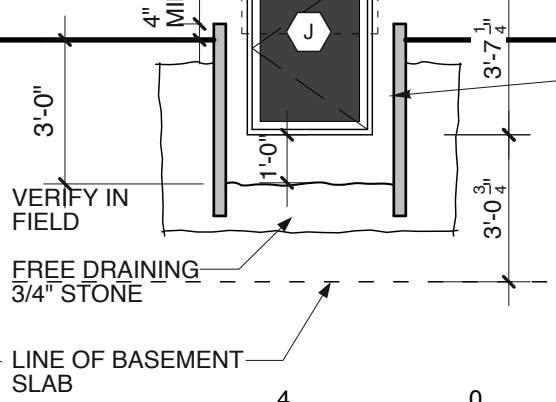

NEW PORCH
ENCLOSURE

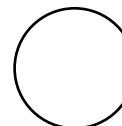

NORTH ELEVATION (Stroudwater Rd.)

SCALE: 1/4" = 1'-0" ref: sheet A2.2

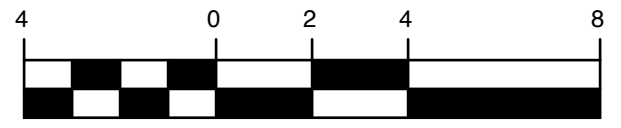

Scale: 1/4 inch = 1 foot

Copyright 2016 Richard Renner | Architects

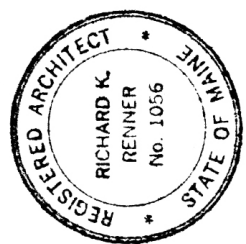

Constantine - Dresser Residence
side elevation (north)

Project No. 2014-01100

Scale:

Date: 03/29/2016 Revised:

RRA

Richard Renner | Architects
Portland, ME 207.773.9699
Sherborn, MA 508.651.2385

Constantine
Dresser
Residence
SKA-10