

PERMIT ISSUED

City of Portland, Maine - Building or Use Permit Application
389 Congress Street, 04101 Tel: (207) 874-8703, Fax: (207) 874-8716

| | | |
|-----------------------|-----------------------------------|---------------------|
| Permit No: 03-1396 | Issue Date: NOV 10 2003 | CBL: 226 A014001 |
|-----------------------|-----------------------------------|---------------------|

| | | | |
|-----------------------------------------------------|----------------------------------------|------------------------------------------------------------------|-----------------------------|
| Location of Construction: 64 Kingsmark Ln | Owner Name: Kelly John C & | Owner Address: 64 Kingsmark Ln CITY OF PORTLAND | Phone: 3-7369 |
| Business Name: | Contractor Name: Steven Foss | Contractor Address: 69 Romano Rd South Portland | Phone: 2077675729 |
| Lessee/Buyer's Name | Phone: | Permit Type: Alterations - Dwellings | Zone: R-2 |

| | | | | | |
|-----------------------------------|-------------------------------------------------|--------------------------------|-------------------------------------|---------------------------|------------------|
| Past Use: Single Family | Proposed Use: Single Family w/mudroom | Permit Fee: \$147.00 | Cost of Work: \$14,000.00 | CEO District: 3 | <i>Shoreland</i> |
|-----------------------------------|-------------------------------------------------|--------------------------------|-------------------------------------|---------------------------|------------------|

| | | |
|------------------------------------------------------------------------------------------------------|-------------------------------------------------------------------------------------------|------------------------------------------------------------------------------------|
| Proposed Project Description: Create a mudroom in the existing garage with partition walls | FIRE DEPT: <input type="checkbox"/> Approved <input type="checkbox"/> Denied | INSPECTION: Use Group: <i>R3</i> Type: <i>SB</i> <i>Box A 1999</i> |
| | Signature: _____ | Signature: <i>JMB 11/10/03</i> |

| |
|--------------------------------------------------------------------------------------------------------------------------|
| PEDESTRIAN ACTIVITIES DISTRICT (P.A.D.) |
| Action: <input type="checkbox"/> Approved <input type="checkbox"/> Approved w/Conditions <input type="checkbox"/> Denied |
| Signature: _____ Date: _____ |

| | | |
|--------------------------------|----------------------------------------|------------------------|
| Permit Taken By: jmb | Date Applied For: 11/10/2003 | Zoning Approval |
|--------------------------------|----------------------------------------|------------------------|

| | | | |
|-----------------------------------------------------------------------------------------------------------------------------------------------------------------------------------------------------------------------------------------------------------------------------------------------------------------------------------------------------------------------------------------------------------------------------|-------------------------------------------------------------------------------------------------------------------------------------------------------------------------------------------------------------------------------------------------------------------------------------------------------------------------------------------------------|---------------------------------------------------------------------------------------------------------------------------------------------------------------------------------------------------------------------------------------------------------------------------------------|-----------------------------------------------------------------------------------------------------------------------------------------------------------------------------------------------------------------------------------------------------------------------------------------------------------------------------------------------|
| <ol style="list-style-type: none"> This permit application does not preclude the Applicant(s) from meeting applicable State and Federal Rules. Building permits do not include plumbing, septic or electrical work. Building permits are void if work is not started within six (6) months of the date of issuance. False information may invalidate a building permit and stop all work.. | Special Zone or Reviews <input type="checkbox"/> Shoreland <input type="checkbox"/> Wetland <input type="checkbox"/> Flood Zone <input type="checkbox"/> Subdivision <input type="checkbox"/> Site Plan Maj <input type="checkbox"/> Minor <input type="checkbox"/> MM <input type="checkbox"/> Date: <i>JMB 11/10/03</i> | Zoning Appeal <input type="checkbox"/> Variance <input type="checkbox"/> Misclassification <input type="checkbox"/> Conditional Use <input type="checkbox"/> Interpretation <input type="checkbox"/> Approved <input type="checkbox"/> Denied Date: _____ | Historic Preservation <input checked="" type="checkbox"/> Not in District or Landmark <input type="checkbox"/> Does Not Require Review <input type="checkbox"/> Requires Review <input type="checkbox"/> Approved <input type="checkbox"/> Approved w/Conditions <input type="checkbox"/> Denied Date: <i>JMB</i> |
| | <i>Approved</i> <i>Not an expansion interior partitions</i> <i>pane 12 zone X white</i> | | |

CERTIFICATION

I hereby certify that I am the owner of record of the named property, or that the proposed work is authorized by the owner of record and that I have been authorized by the owner to make this application as his authorized agent and I agree to conform to all applicable laws of this jurisdiction. In addition, if a permit for work described in the application is issued, I certify that the code official's authorized representative shall have the authority to enter all areas covered by such permit at any reasonable hour to enforce the provision of the code(s) applicable to such permit.

| | | | |
|---------------------------------------------|---------|------|-------|
| SIGNATURE OF APPLICANT | ADDRESS | DATE | PHONE |
| RESPONSIBLE PERSON IN CHARGE OF WORK, TITLE | | DATE | PHONE |

City of Portland, Maine - Building or Use Permit

389 Congress Street, 04101 Tel: (207) 874-8703, Fax: (207) 874-8716

| | | |
|------------------------------|----------------------------------------|----------------------------|
| Permit No: 03-1396 | Date Applied For: 11/10/2003 | CBL: 226 A014001 |
|------------------------------|----------------------------------------|----------------------------|

| | | | |
|-----------------------------------------------------|----------------------------------------|-----------------------------------------------------------|---------------------------------|
| Location of Construction: 64 Kingsmark Ln | Owner Name: Kelly John C & | Owner Address: 64 Kingsmark Ln | Phone: () 733-7369 |
| Business Name: | Contractor Name: Steven Foss | Contractor Address: 69 Romano Rd South Portland | Phone: (207) 767-5729 |
| Lessee/Buyer's Name | Phone: | Permit Type: Alterations - Dwellings | |

| | |
|-------------------------------------------------|------------------------------------------------------------------------------------------------------|
| Proposed Use: Single Family w/mudroom | Proposed Project Description: Create a mudroom in the existing garage with partition walls |
|-------------------------------------------------|------------------------------------------------------------------------------------------------------|

| | | | |
|-----------------------------------------------------------------------------------------------------------------------------------------------------|-------------------------|---------------------------------|---------------------------------------------------------|
| Dept: Zoning | Status: Approved | Reviewer: Jeanine Bourke | Approval Date: 11/10/2003 |
| Note: | | | Ok to Issue: <input checked="" type="checkbox"/> |
| 1) This property shall remain a single family dwelling. Any change of use shall require a separate permit application for review and approval. | | | |
| 2) This property is in the shoreland zone but the work is not expanding the dwelling. Partition walls will create a mudroom in the existing garage. | | | |

| | | | |
|-----------------------|-------------------------|---------------------------------|---------------------------------------------------------|
| Dept: Building | Status: Approved | Reviewer: Jeanine Bourke | Approval Date: 11/10/2003 |
| Note: | | | Ok to Issue: <input checked="" type="checkbox"/> |

BUILDING PERMIT INSPECTION PROCEDURES

Please call 874-8703 or 874-8693 to schedule your inspections as agreed upon

Permits expire in 6 months, if the project is not started or ceases for 6 months.

The Owner or their designee is required to notify the inspections office for the following inspections and provide adequate notice. Notice must be called in 48-72 hours in advance in order to schedule an inspection:

By initialzing at each inspection time, you are agreeing that you understand the inspection procedure and additional fees from a "Stop Work Order" and "Stop Work Order Release" will be incurred if the procedure is not followed as stated below.

JB Pre-construction Meeting: Must be scheduled with your inspection team upon receipt of this permit. Jay Reynolds, Development Review Coordinator at 874-8692 must also be contacted at this time, before any site work begins on any project other than single family additions or alterations.

- | | | |
|-------------------------------------|----------------------------------------------|-----------------------------------------------------------------------------------------------------------------------|
| <input type="checkbox"/> | <u>Footing/Building Location Inspection:</u> | Prior to pouring concrete |
| <input type="checkbox"/> | <u>Re-Bar Schedule Inspection:</u> | Prior to pouring concrete |
| <input type="checkbox"/> | <u>Foundation Inspection:</u> | Prior to placing ANY backfill |
| <input checked="" type="checkbox"/> | <u>Framing/Rough Plumbing/Electrical:</u> | Prior to any insulating or drywalling |
| <input checked="" type="checkbox"/> | <u>Final Certificate of Occupancy:</u> | Prior to any occupancy of the structure or use. NOTE: There is a \$75.00 fee per inspection at this point. |

Certificate of Occupancy is not required for certain projects. Your inspector can advise you if your project requires a Certificate of Occupancy. All projects DO require a final inspection

If any of the inspections do not occur, the project cannot go on to the next phase, REGARDLESS OF THE NOTICE OR CIRCUMSTANCES.

NA **CERIFICATE OF OCCUPANICES MUST BE ISSUED AND PAID FOR, BEFORE THE SPACE MAY BE OCCUPIED**

Steven L. Jaro
Signature of applicant/designee

Date 11/10/03

James Baraka
Signature of Inspections Official

Date

CBL: 226-A14

Building Permit #: 03-1396

All Purpose Building Permit Application

If you or the property owner owes real estate or personal property taxes or user charges on any property within the City, payment arrangements must be made before permits of any kind are accepted.

| | | |
|---------------------------------------------------------------------------------------------------------------------------------------------------------------------------------------------------------------------------------------------------------------------------------------------------------------|-------------------------------------------------------------------------------------------------------|--------------------------------------------------------------------------------|
| Location/Address of Construction: <u>64 KingsMark Ln. Portland, Me. 04102</u> | | |
| Total Square Footage of Proposed Structure <u>408</u> | Square Footage of Lot | |
| Tax Assessor's Chart, Block & Lot Chart# Block# Lot# <u>226 A 014</u> | Owner: <u>John Kelly</u> <u>Catherine O'Connor</u> | Telephone: <u>773-7369</u> |
| Lessee/Buyer's Name (If Applicable) | Applicant name, address & telephone: <u>Steven Foss 69 Romano Rd So Portland Me 04106 767-5129</u> | Cost Of Work: \$ <u>30,000.00</u> <u>14,000.00</u> Fee: \$ <u>147.00</u> |
| Current use: <u>SFR</u> | | |
| If the location is currently vacant, what was prior use: _____ | | |
| Approximately how long has it been vacant: _____ | | |
| Proposed use: <u>add mudroom in existing ^{garage} space</u> | | |
| Project description: | | |
| Contractor's name, address & telephone: <u>Steven Foss 69 Romano Rd So Portland Me 04106 767-5129</u> | | |
| Who should we contact when the permit is ready: <u>Steve</u> | | |
| Mailing address: <u>Steven Foss 69 Romano Rd So Portland Me 04106</u> | | |
| We will contact you by phone when the permit is ready. You must come in and pick up the permit and review the requirements before starting any work, with a Plan Reviewer. A stop work order will be issued and a \$100.00 fee if any work starts before the permit is picked up. PHONE: <u>767-5129</u> | | |

IF THE REQUIRED INFORMATION IS NOT INCLUDED IN THE SUBMISSIONS THE PERMIT WILL BE AUTOMATICALLY DENIED AT THE DISCRETION OF THE BUILDING/PLANNING DEPARTMENT, WE MAY REQUIRE ADDITIONAL INFORMATION IN ORDER TO APPROVE THIS PERMIT.

I hereby certify that I am the Owner of record of the named property, or that the owner of record authorizes the proposed work and that I have been authorized by the owner to make this application as his/her authorized agent. I agree to conform to all applicable laws of this jurisdiction. In addition, if a permit for work described in this application is issued, I certify that the Code Official's authorized representative shall have the authority to enter all areas covered by this permit at any reasonable hour to enforce the provisions of the codes applicable to this permit.

| | |
|--------------------------------------------|-------|
| Signature of applicant: <u>Steven Foss</u> | Date: |
|--------------------------------------------|-------|

**This is NOT a permit, you may not commence ANY work until the permit is issued.
If you are in a Historic District you may be subject to additional permitting and fees with the
Planning Department on the 4th floor of City Hall**

Stair detail
 For 64
 Kingsmark Lane
 Portland, Me. 04102

Kelly - O'Connor

Mudroom stairs

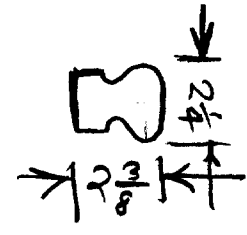

Treads 5" x 11" x 48"

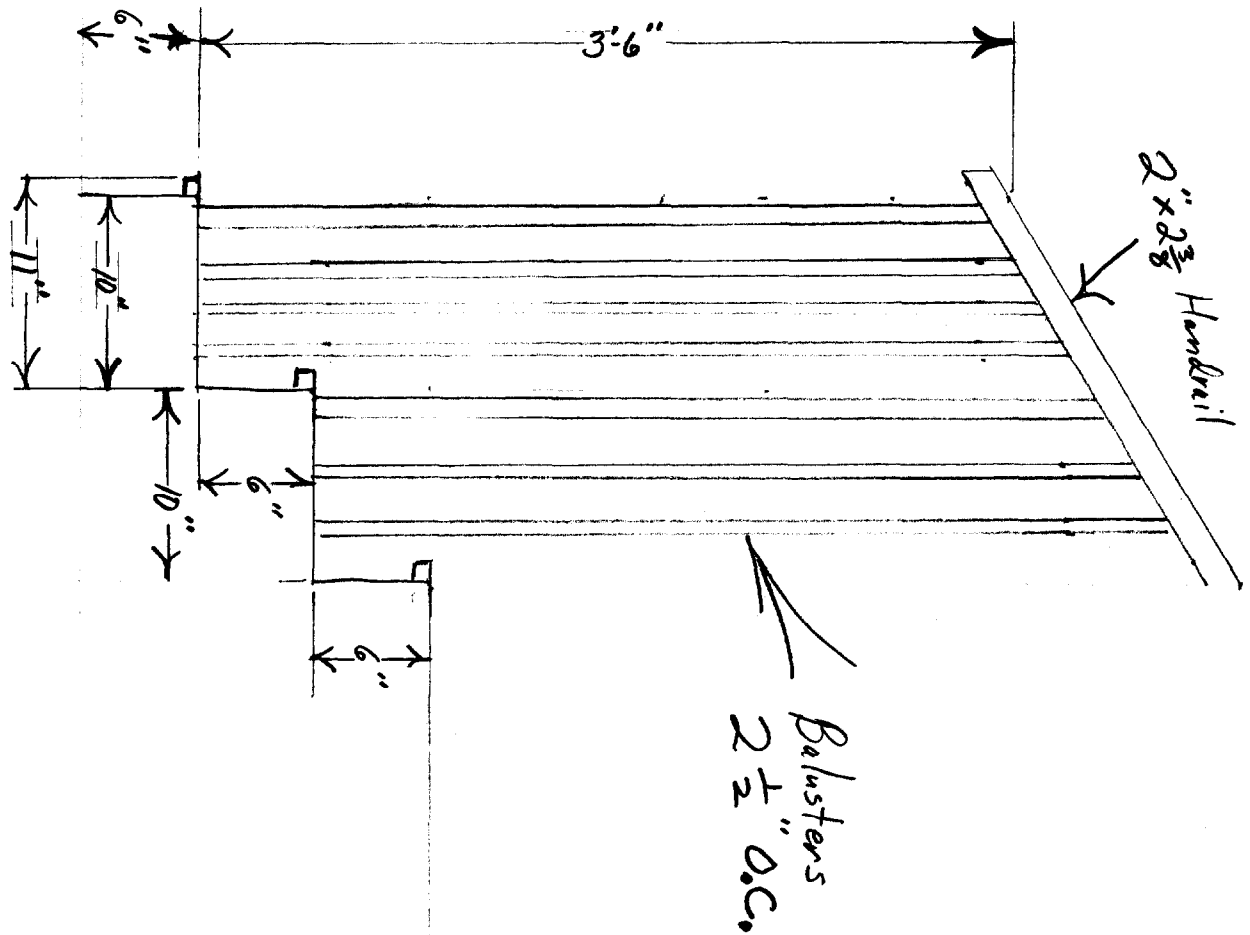

DISPLAY THIS CARD ON PRINCIPAL FRONTAGE OF WORK CITY OF PORTLAND

Please Read Application And Notes, if Any, Attached

BUILDING DEPARTMENT

PERMIT ISSUED

Permit Number: 031396

NOV 10 2003

PERMIT

This is to certify that Kelly John C &/Steven Foss

has permission to Create a mudroom in the existing garage with partition walls

CITY OF PORTLAND

AT 64 Kingsmark Ln 226 A014001

provided that the person or persons, firm or corporation accepting this permit shall comply with all of the provisions of the Statutes of the State and of the Ordinances of the City of Portland regulating the construction, maintenance and use of buildings and structures, and of the application on file in this department.

Apply to Public Works for street line and grade if nature of work requires such information.

Notification of inspection must be given and written permission procured before this building or part thereof is leased or occupied. **48 HOUR NOTICE IS REQUIRED.**

A certificate of occupancy must be procured by owner before this building or part thereof is occupied.

OTHER REQUIRED APPROVALS

Fire Dept. _____

Health Dept. _____

Appeal Board _____

Other _____

Department Name

[Signature] 11/10/03
Director Building & Inspection Services

PENALTY FOR REMOVING THIS CARD