

No 225

SHEET 238-C

CITY 45 86450

258 B-1
258 B-2
258 B-3
258 B-4
258 B-5
258 B-6
258 B-7
258 B-8
258 B-9
258 B-10
258 B-11
258 B-12
258 B-13
258 B-14
258 B-15
258 B-16
258 B-17
258 B-18
258 B-19
258 B-20
258 B-21
258 B-22
258 B-23
258 B-24
258 B-25
258 B-26
258 B-27
258 B-28
258 B-29
258 B-30
258 B-31
258 B-32
258 B-33
258 B-34
258 B-35
258 B-36
258 B-37
258 B-38
258 B-39
258 B-40
258 B-41
258 B-42
258 B-43
258 B-44
258 B-45
258 B-46
258 B-47
258 B-48
258 B-49
258 B-50
258 B-51
258 B-52
258 B-53
258 B-54
258 B-55
258 B-56
258 B-57
258 B-58
258 B-59
258 B-60
258 B-61
258 B-62
258 B-63
258 B-64
258 B-65
258 B-66
258 B-67
258 B-68
258 B-69
258 B-70
258 B-71
258 B-72
258 B-73
258 B-74
258 B-75
258 B-76
258 B-77
258 B-78
258 B-79
258 B-80
258 B-81
258 B-82
258 B-83
258 B-84
258 B-85
258 B-86
258 B-87
258 B-88
258 B-89
258 B-90
258 B-91
258 B-92
258 B-93
258 B-94
258 B-95
258 B-96
258 B-97
258 B-98
258 B-99
258 B-100

SHEET 226-B

SHEET 222-B

SHEET 224-A

SHEET 239-C



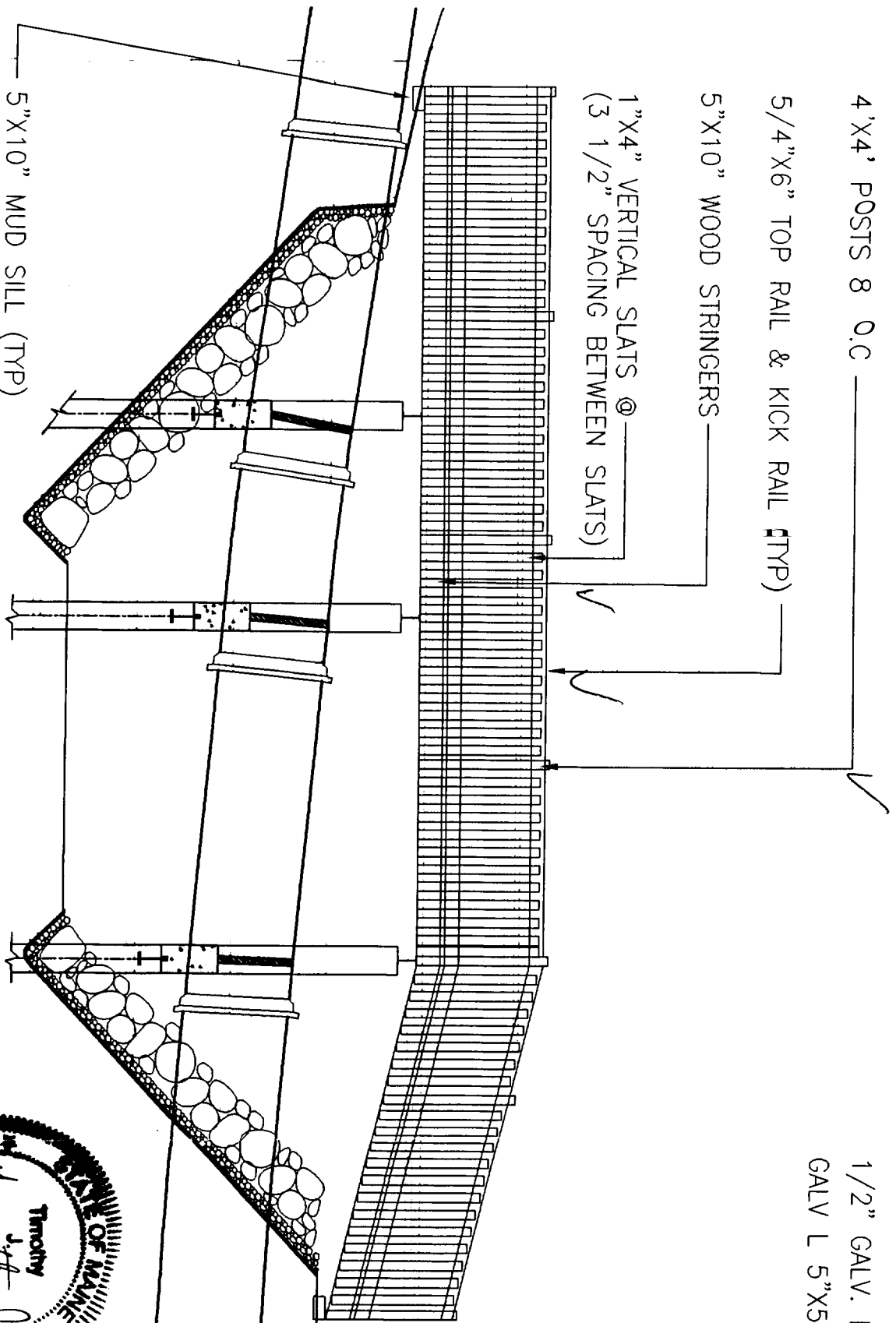

PROPOSED FOOT BRIDGE

SCALE: 3/16"=1'



Timothy J. McLaughlin

NOTES:
SECURE ALL WOOD WITH GALVANIZED SCREWS.

4"X4" PT POSTS (TYP) _____
CHAMFER ALL TOP SIDES
5/4"X6" PT RAILS (TYP) _____
3"X8" DECKING _____
5"X10" STRINGERS _____
1/2" GALV. LAG BOLTS (TYP) _____
GALV L 5"X5"X1/4" (TYP) _____

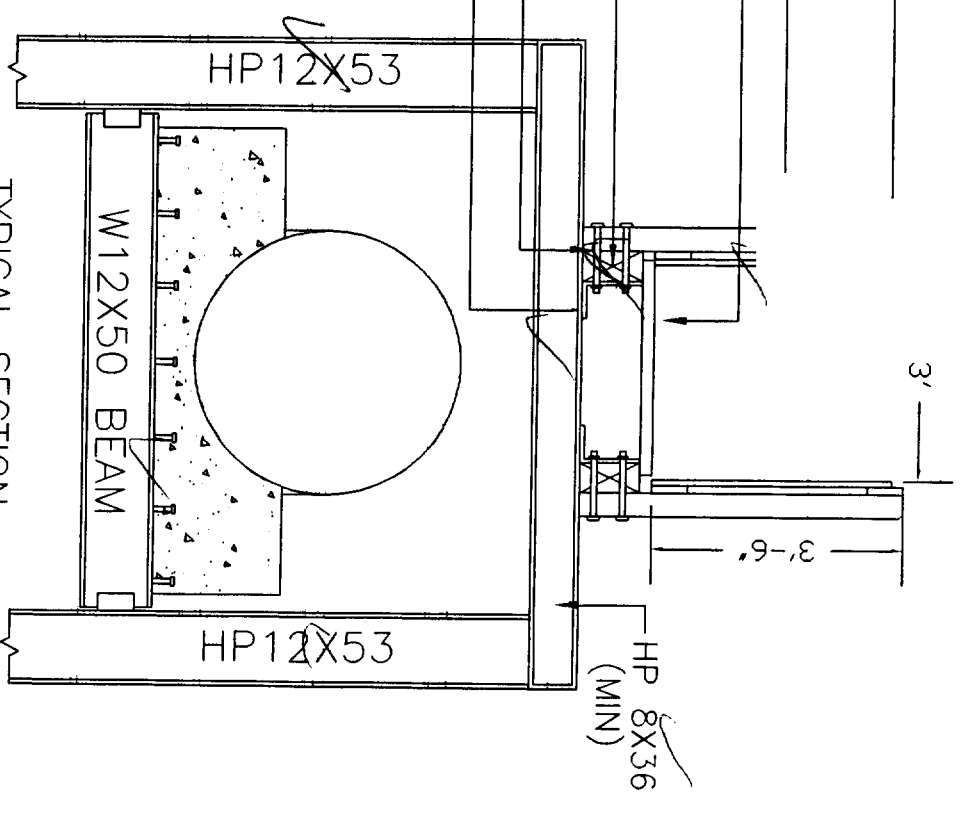

TYPICAL SECTION

SCALE: 3/8"=1'

STROUDWATER 42' C.I. REPAIR	
FOOT BRIDGE LAYOUT AND SECTION	
 Portland Water District <small>PLANNING ENGINEERING ENVIRONMENTAL CONSTRUCTION MAINTENANCE OPERATIONS</small>	
DATE	DESCRIPTION
1/29/01	1 OF 1

12"
HARDWOOD

N/F GORHAM AND
GRAVEL

25

20

15

10

5

FORE RIVER CREEK

1 2 3 4

5

N/F MAINE AUDUBON SOCIETY

6

PROPOSED CONTOURS

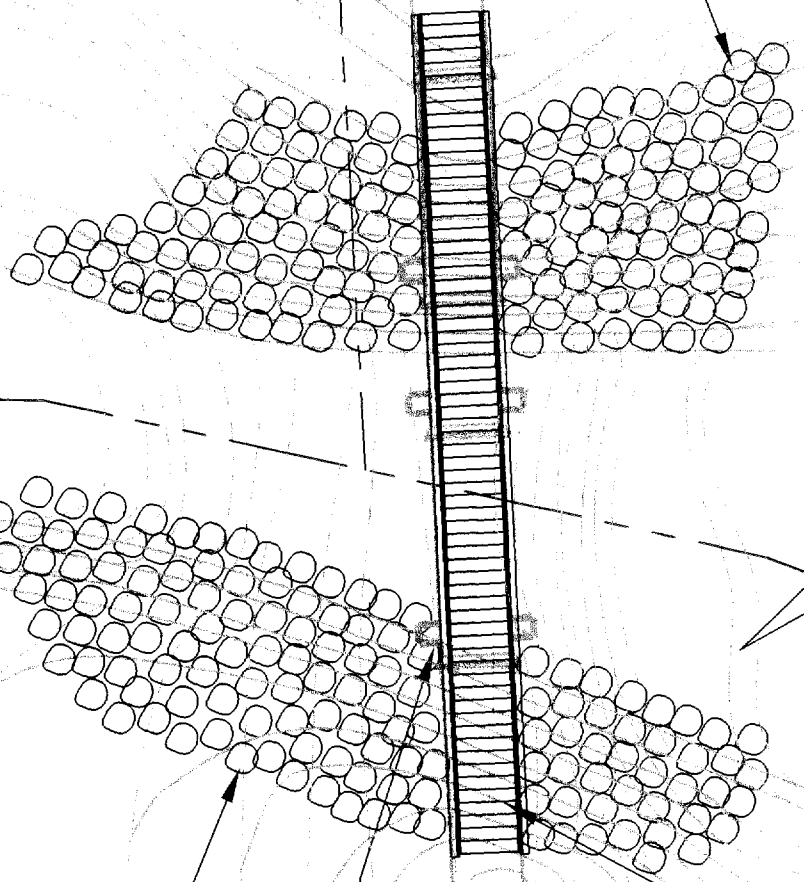

RIP-RAP PER SPECS.

INSTALL PIPE SUPPORTS AND PILES
(3 LOCATIONS). SEE DETAIL SHEET 3.

42" CAST IRON WATER MAIN
LEADED JOINTS @ 12' TYP.

PROSED FOOT BRIDGE
SEE SHEET 2

MARKER POST

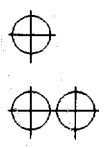

BLOW OFF VALVE

10

1
2
3
4

5

6

7

8

STROUDWATER 42" C.I. REPAIR		DESIGN		TM	
FOOT BRIDGE PLAN VIEW		DRAWN		JS	
 Portland Water District <small>ENGINEERING DEPARTMENT</small>		CHECKED		TM	
REVISIONS	DATE	DESCRIPTION	BY	DATE	BY

PROJECT NUMBER	FILE	SCALE	TITLE	SHEET
2737RM_W0007		1"=10'	1/26/01	1 OF 2