

# DOOR & FRAME SCHEDULE

MARK	DOOR			FRAME			HARDWARE		REMARKS
	SIZE	MTRL	TYPE	MTRL	TYPE	DETAIL	FIRE RATING	SET FUNCTION NO.	
1	3'-0"	7'-0"	1 3/4"	FG	1	WD		LOCKSET	PANIC BAR
2	3'-0"	7'-0"	1 3/4"	WD	2	WD		PASSAGE	
3	3'-0"	7'-0"	1 3/4"	WD	3	WD		PRIVACY	
4	3'-0"	7'-0"	1 3/4"	WD	3	WD		PRIVACY	
5	3'-0"	7'-0"	1 3/4"	WD	3	WD		STORAGE LOCK	
6	3'-0"	7'-0"	1 3/4"	WD	3	WD		STORAGE LOCK	
7	3'-0"	7'-0"	1 3/4"	WD	3	WD		STORAGE LOCK	
8	3'-0"	7'-0"	1 3/4"	FG	5	WD		LOCKSET	
9	3'-0"	7'-0"	1 3/4"	FG	4	WD		STORAGE LOCK	
10	3'-0"	7'-0"	1 3/4"	FG	6	WD		LOCKSET	
11	9'-0"	7'-0"	1 3/4"	WD	8	WD		DEAD BOLT	SEE DETAIL DWG. NO. A-
12	9'-0"	7'-0"	1 3/4"	WD	8	WD		DEAD BOLT	SEE DETAIL DWG. NO. A-
13	3'-0"	7'-0"	1 3/4"	FG	4	WD		LOCKSET	
14	3'-0"	7'-0"	1 3/4"	WD	3	WD	3/4 HR	LOCKSET	
15	3'-0"	7'-0"	1 3/4"	WD	3	WD		STORAGE LOCK	
16	3'-0"	7'-0"	1 3/4"	WD	3	WD	3/4 HR	PASSAGE SET	
17	3'-0"	7'-0"	1 3/4"	WD	3	WD	3/4 HR	PASSAGE SET	
18	3'-0"	7'-0"	1 3/4"	FG	4	WD		LOCKSET	
19	3'-0"	7'-0"	1 3/4"	WD	3	WD		PASSAGE SET	
20	2'-0"	7'-0"	1 3/4"	WD	3	WD		BI-PASS	
21	3'-0"	7'-0"	1 3/4"	WD	3	WD		PRIVACY LOCK	
22	3'-0"	7'-0"	1 3/4"	WD	3	WD		LOCKSET	
23	3'-0"	7'-0"	1 3/4"	FG	1	WD		PASSAGE	REVERSE HARDWARE w/ DOOR-1
24	3'-0"	7'-0"	1 3/4"	WD	3	WD		PRIVACY	
25	3'-0"	7'-0"	1 3/4"	WD	3	WD		PRIVACY	
26	3'-0"	7'-0"	1 3/4"	WD	3	WD		OFFICE LOCK	
27	3'-0"	7'-0"	1 3/4"	WD	7	WD		OFFICE LOCK	
28	3'-0"	7'-0"	1 3/4"	WD	3	WD		OFFICE LOCK	
29	3'-0"	7'-0"	1 3/4"	FG	4	WD		LOCKSET	
30	3'-0"	7'-0"	1 3/4"	WD	3	WD		OFFICE LOCK	
31	RR 3'-0"	7'-0"	1 3/4"	WD	2	WD	3/4 HR	PASSAGE SET	MAGNETIC HOLD OPEN
32	RR 3'-0"	7'-0"	1 3/4"	WD	2	WD	3/4 HR	PASSAGE SET	MAGNETIC HOLD OPEN
33	3'-0"	7'-0"	1 3/4"	WD	3	WD		PASSAGE SET	
34	3'-0"	7'-0"	1 3/4"	FG	4	WD		LOCKSET	PANIC BAR - EXIT ONLY
35	3'-0"	7'-0"	1 3/4"	FG	4	WD		LOCKSET	PANIC BAR - EXIT ONLY

**GENERAL NOTES DOORS AND HARDWARE**

- APPROPRIATE DOORSTOPS SHALL BE INSTALLED FOR ALL DOORS WHERE REQUIRED, PROVIDE FLOOR OR WALL MOUNTED DOORSTOPS TO PREVENT DOOR TRIM FROM DAMAGING THE WALL.
- HINGES SHALL BE 4 1/2" X 4 1/2" UNLESS OTHERWISE NOTED. PROVIDE NON-REMOVABLE PINS FOR ALL EXTERIOR DOORS WITH EXPOSED HINGE KNUCKLES.
- ALL EXTERIOR DOORS SHALL BE INSULATED, WEATHER-STRIPPED, AND CALK ON ALL SIDES. PROVIDE METAL THRESHOLD.
- UNDERCUT ALL DOORS AS REQUIRED FOR FLOOR FINISH INSTALLATION.
- FINISH HARDWARE TO BE 10B OIL RUBBED BRONZE.
- ALL DOORS TO HAVE LEVER HANDLES TO MEET ADA.

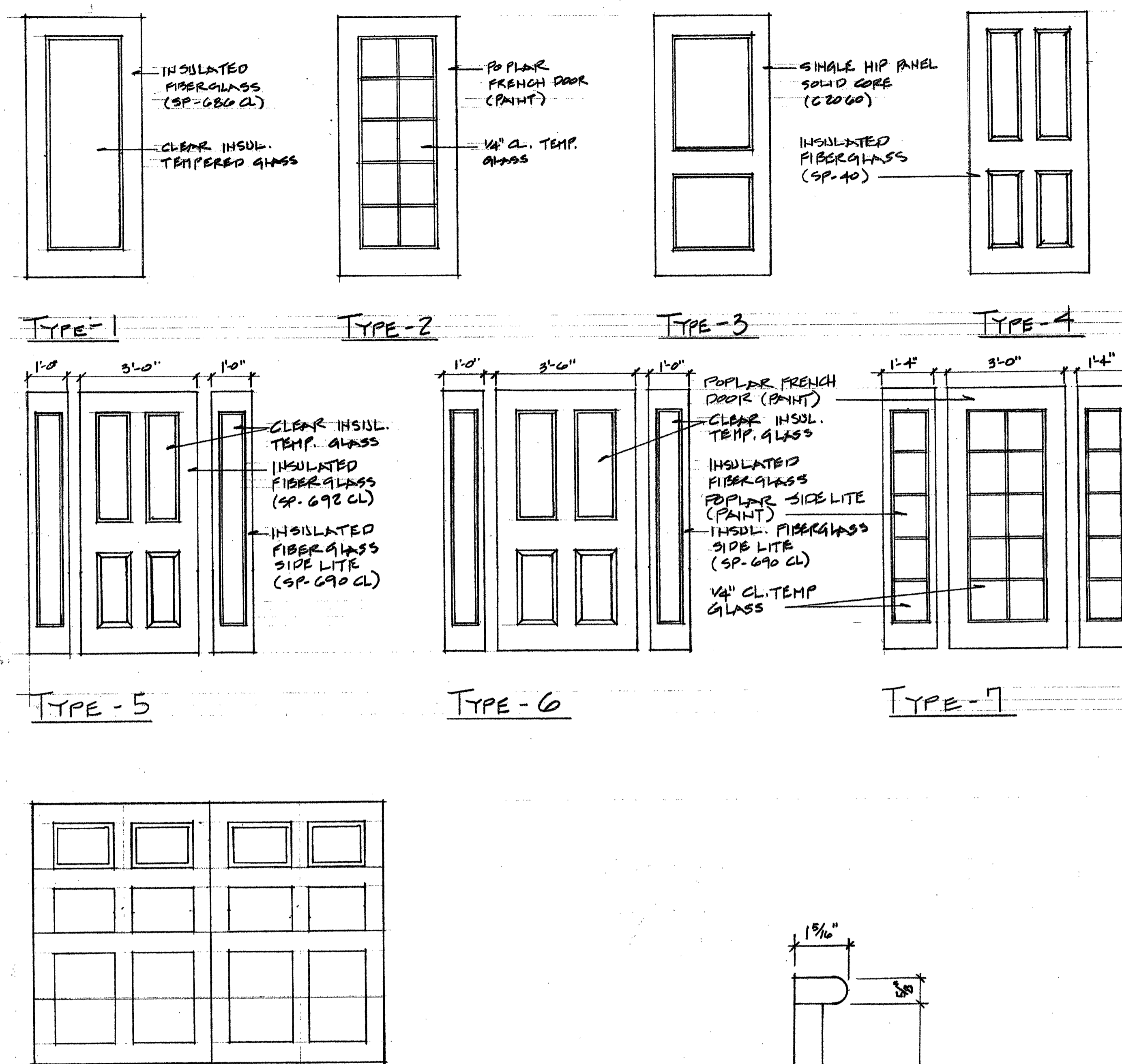

## DOOR TYPES

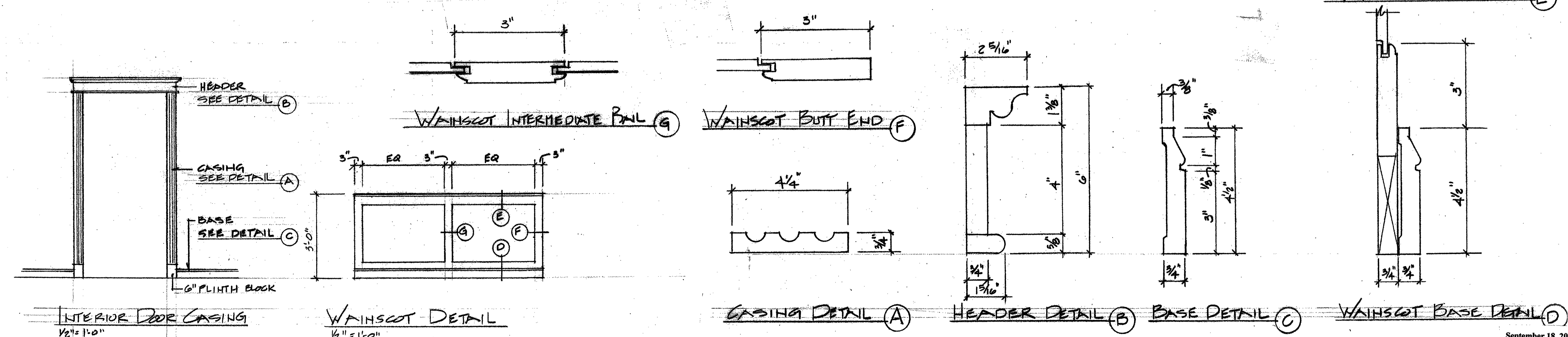

Project Title
Project No.

Hutchins Funeral Home  
660 Brighton Avenue  
Portland, Maine

Drawing Title
Scale

Door and Frame Schedule

Drawing No.
Date

A-7.0

DLL Associates / Architects

108 Main Street, Suite C, Lewiston, Maine 04240 (207) 344-6611 DILAIA@AOL.COM

September 18, 2009  
Building Permit Submission  
Review and Approval  
NOT FOR CONSTRUCTION