

HEAT BE
FORCED WATER

THIS PLAN AND SPECIFICATIONS HAVE NOT BEEN REPEARED BY A REGISTERED ARCHITECT OR ENGINEER FOR THE PURPOSE OF OBTAINING A LICENSE IN THE STATE OF MAINE. THE ARCHITECT ASSUMES NO LIABILITY FOR THE PROVISIONS OF THIS PLAN AND SPECIFICATIONS AS A SERVICE AND IN NO WAY CONSTITUTE A GUARANTEE TO THE EXACTNESS OR ACCURACY OF THE INFORMATION PROVIDED HEREON. THE ARCHITECT ASSUMES NO LIABILITY FOR THE PROVISIONS OF THIS PLAN AND SPECIFICATIONS AS A SERVICE AND IN NO WAY CONSTITUTE A GUARANTEE TO THE EXACTNESS OR ACCURACY OF THE INFORMATION PROVIDED HEREON.

LOT 2
RIVERS
EDGE

MARDIGAN
SPEC HOUSE

PROJECT NAME

REVISIONS
DATE
SCALE
DRAWN
FILE
SHEET #

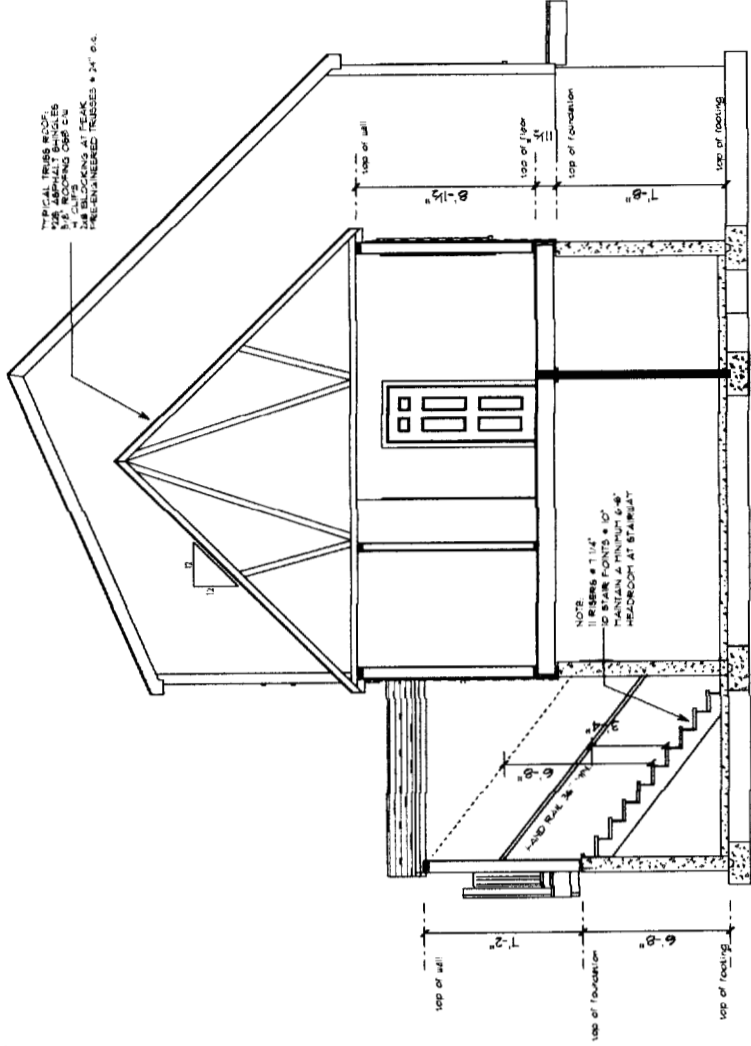

CROSS SECTION A-A
FRAMING DETAIL THE SAME AS
SECTION A-A. SCALE 1/4" = 1'-0"

CITY OF PORTLAND, MAINE
APPROVED CONSTRUCTION PLANS
DEC 22 2004
SUPERSEDES ALL
PRIOR DATED PLANS

DEC 2

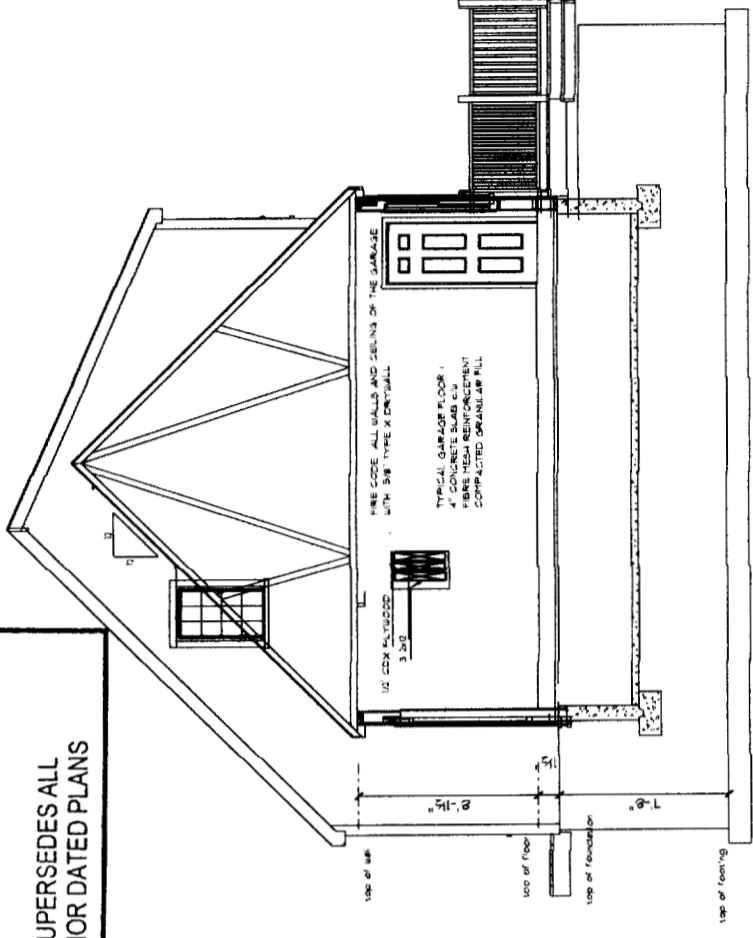

CROSS SECTION B-B
FRAMING DETAIL THE SAME AS
SECTION A-A. SCALE 1/4" = 1'-0"

TYPICAL STAIR DETAIL

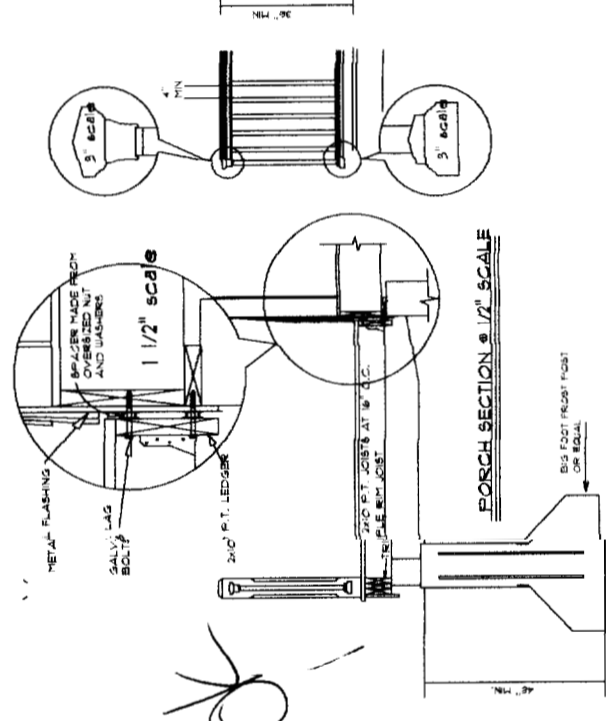
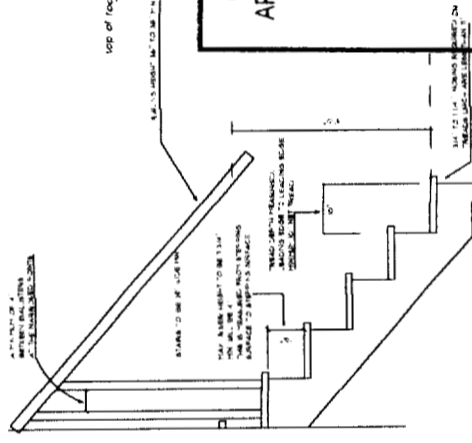

CROSS SECTION C-C
FRAMING DETAIL THE SAME AS
SECTION A-A. SCALE 1/4" = 1'-0"

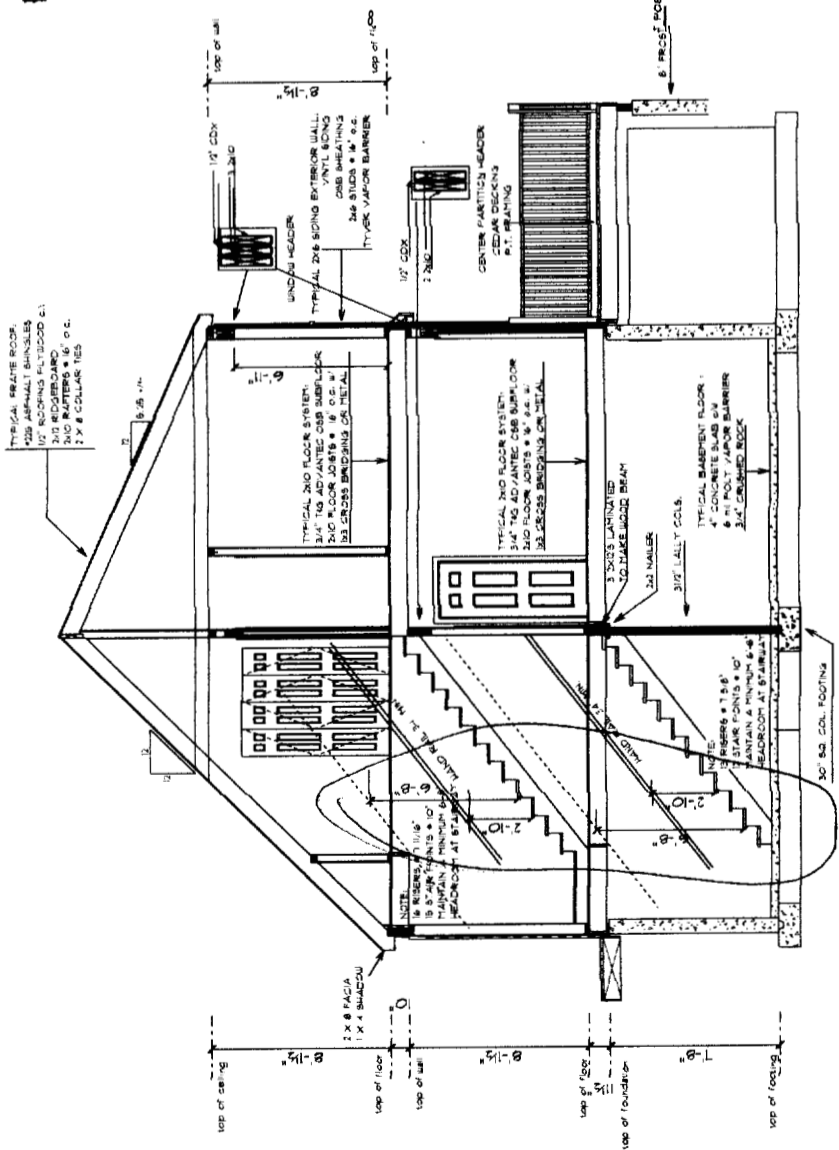

CROSS SECTION C-C
SCALE 1/4" = 1'-0"

OK

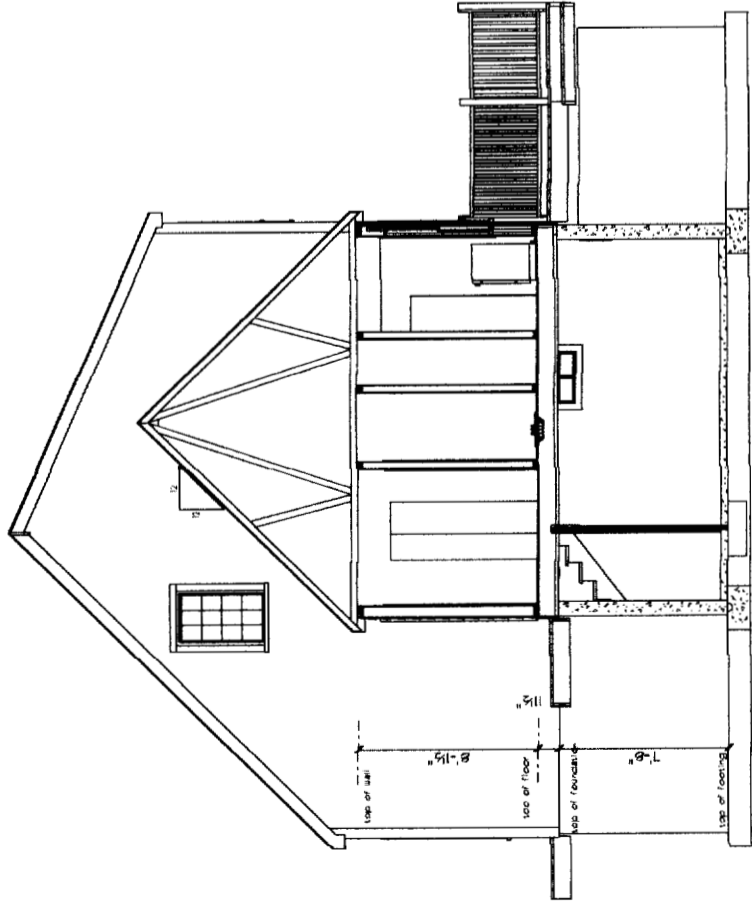

CROSS SECTION D-D
FRAMING DETAIL THE SAME AS
SECTION A-A. SCALE 1/4" = 1'-0"