



# Trinity Tft60-85-110 High Efficiency Gas Modulating-Condensing Boiler

## Submittal Sheet

Section 1 - Specifications  
Section 2 - Dimensions  
Section 3 - Electrical

Project Name: Clark Insurance Date: \_\_\_\_\_  
 Location: \_\_\_\_\_  
 Engineer: \_\_\_\_\_  
 Contractor: \_\_\_\_\_ Rep: \_\_\_\_\_

### 1 SPECIFICATIONS

#### General Specifications

- ▶ Product Features
  - Certified to ANSI Z21.13 / CSA 4.9 Gas-fired Boiler Standard (pending)
  - ASME "H" stamped boiler, designed and constructed in compliance with the ASME Boiler and Pressure Vessel Code Section IV
  - SA240-S43932 Stainless Steel Heat Exchanger
  - Maximum operating pressure 30 psi [206.8 kPa]
  - Field conversion from Natural Gas (factory) to Propane
  - Modulating burner, 5:1 turndown
  - Direct Spark Ignition
  - Wall (standard) or floor mounting (w/ opt. kit, NTI part # 84630)
  - Zero clearance to combustibles
- ▶ Optional sidewall vent kit (NTI part # 82666 & 84357)
- ▶ Factory Supplied Items
  - 10K thermistor outdoor sensor
  - 30PSI [206.8 kPa] ASME Relief Valve
  - 60PSI [413.7 kPa] Pressure Gauge
- ▶ Control Features
  - Integral microprocessor safety control
  - 2 central heat inputs (high & low temperature)
  - Domestic Hot Water Priority
  - Outdoor reset
  - Warm weather shutdown
  - Lead-Lag up to 8 Tft and Lx series boilers
  - Integrated Modbus RTU for connection to BMS gateways

Model	Water Conn. NPT in.	Gas Connection NPT, in.	Vent/Air-Intake Pipe Diameter in. [mm]	Vent/Air-Inlet Max. Length, NG/LP ft. [m]		Approx. Wt. w/ Water lb. [kg]
				2 in. [50mm] venting	3 in. [50mm] venting	
Tft60	1 (Male)	½ (Male)	2 or 3 [50 or 76]	100/35 [30.5 /10.7]	150/150 [45.7 /45.7]	110 [50]
Tft85				100/25 [30.5 /7.6]		
Tft110						

#### Heating Specifications

Model	Input		Heating Capacity BTU/hr [kW]	AFUE %	Net I=B=R Rating BTU/hr [kW]
	Min BTU/hr [kW]	Max BTU/hr [kW]			
Tft60	17,000 [5]	60,000 [17.5]	56,000 [16.4]	95	48,000 [14.1]
Tft85	17,000 [5]	85,000 [24.9]	78,000 [22.8]		68,000 [19.9]
Tft110	21,600 [6.3]	108,000 [31.6]	99,000 [29.0]		86,000 [25.2]

#### Performance Specifications

Trinity Tft 60-110 Performance

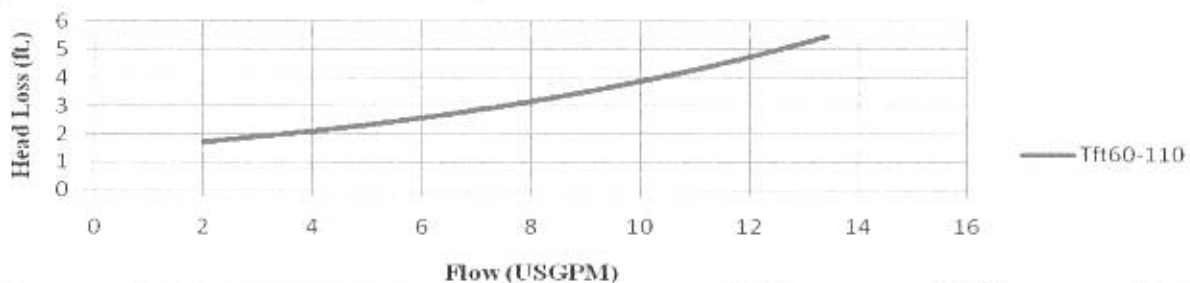

NY Thermal Inc.

65 Drury Cove Road, Saint John, NB E2H 2Z8 Canada

Technical Service: 1-800-688-2575 Fax: 1-506-432-1135 Web: <http://www.nythermal.com>

NY Thermal Inc. reserves the right to change these specifications without notice



**Trinity Tft60-85-110  
High Efficiency Gas  
Modulating-Condensing Boiler**

**Submittal Sheet**

**2 DIMENSIONS**

**Product Dimensions – in. [mm]**

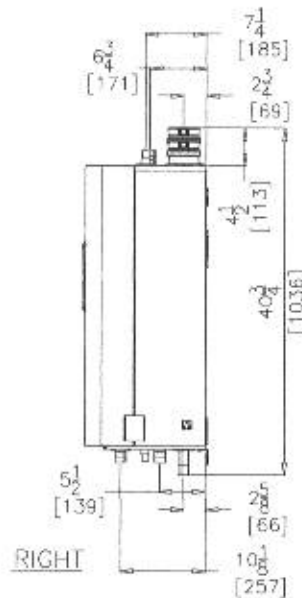
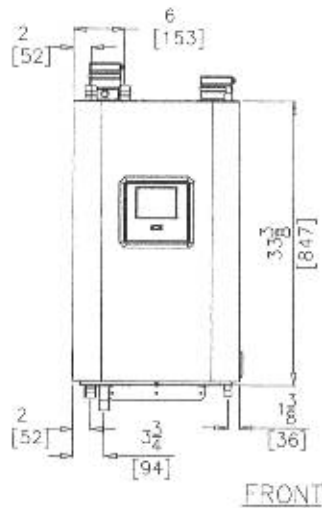
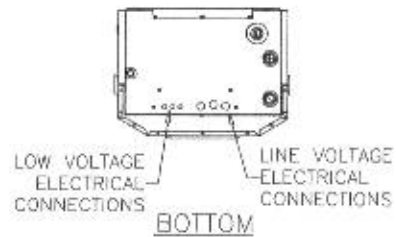
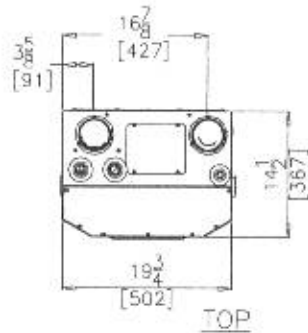

**Recommended Clearances – in. [mm]**

Front	Top	Sides	Back	Bottom	Flue Pipe
36 [914]	24 [610]	12 [305]	0	24 [610]	1 [25]



NY Thermal Inc.

65 Drury Cove Road, Saint John, NB E2H 2Z8 Canada

Technical Service: 1-800-688-2575 Fax: 1-506-432-1135 Web: <http://www.nythermal.com>

NY Thermal Inc. reserves the right to change these specifications without notice



# Trinity Tft60-85-110 High Efficiency Gas Modulating-Condensing Boiler

Submittal Sheet

## 3 ELECTRICAL

### Simplified Wiring Diagrams

#### Line Voltage Electrical:

- ▶ 120VAC / 60 Hz / 1 Phase / 12 Amp
- ▶ Barrier Strip for field wiring terminations
- ▶ 3 Pump outputs
  - Indirect Domestic Hot Water (Pump A)
  - Boiler (Pump B)
  - Central Heat (Pump C)

Note: Pumps are field supplied.

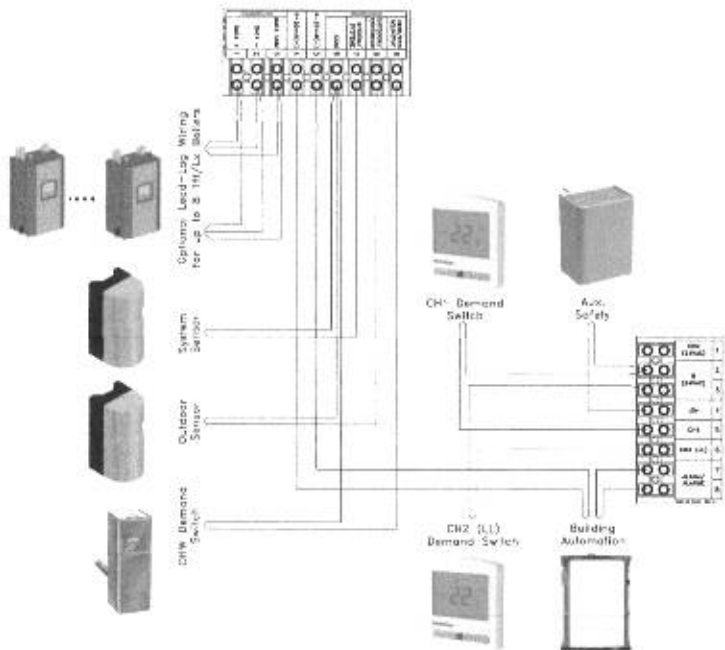
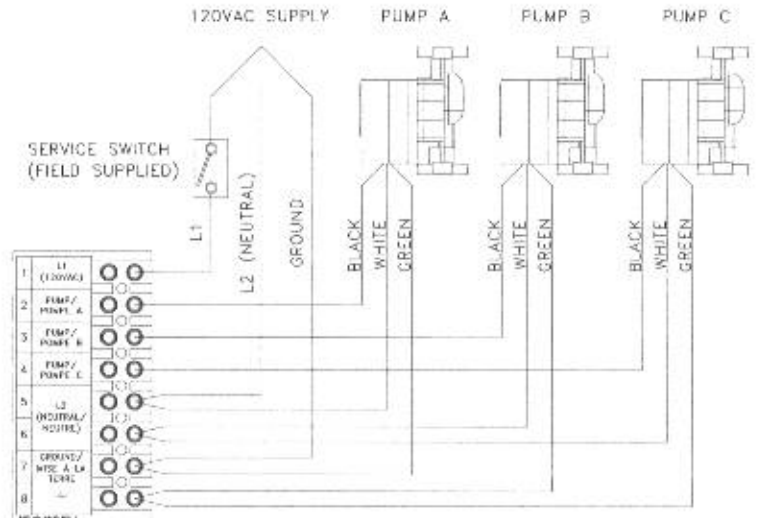

#### Low Voltage Electrical:

- ▶ Barrier Strip for field wiring terminations
- ▶ 120/24 VAC Transformer 40VA (factory supplied)
- ▶ Inputs
  - CH1 thermostat (by others)
  - CH2 thermostat (by others)
  - Indirect DHW aquastat (by others) or DHW Tank sensor (factory option)
  - External Limit (by others)
  - Outdoor sensor (factory supplied)
  - System sensor (factory option)
  - 4-20mA external modulating control (by others)
- ▶ Outputs
  - Alarm dry contact (24VAC 0.63A max.)
- ▶ EIA-485 Modbus communications for Lead-Lag
- ▶ EIA-485 Modbus to BMS gateways (not shown). Optional available gateways:
  - BACnet/N2- NTI part # 84946
  - LonWorks- NTI part # 84947

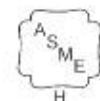

NY Thermal Inc.

65 Drury Cove Road, Saint John, NB E2H 2Z8 Canada

Technical Service: 1-800-688-2575 Fax: 1-506-432-1135 Web: <http://www.nythermal.com>

NY Thermal Inc. reserves the right to change these specifications without notice