

5 COSMETIC ENHANCEMENT
1/4" = 1'-0"

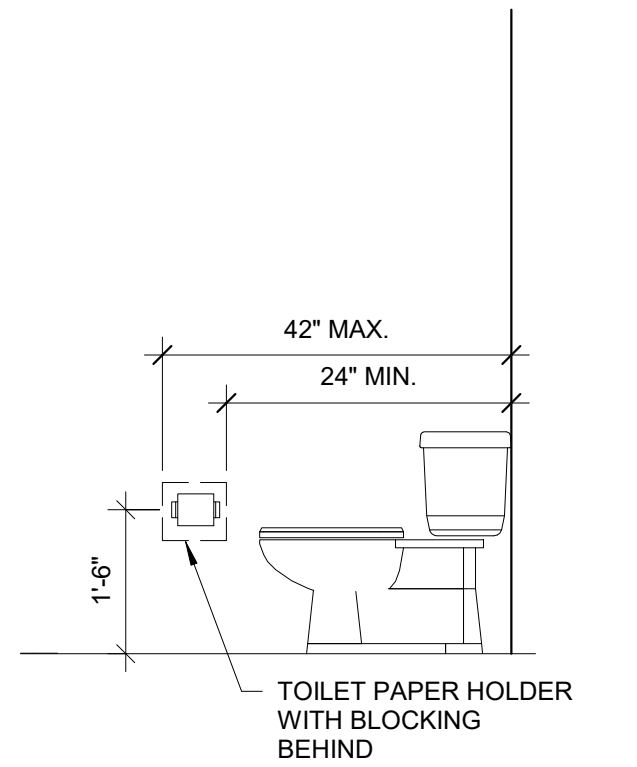

3 ADVANCED VEIN
1/4" = 1'-0"

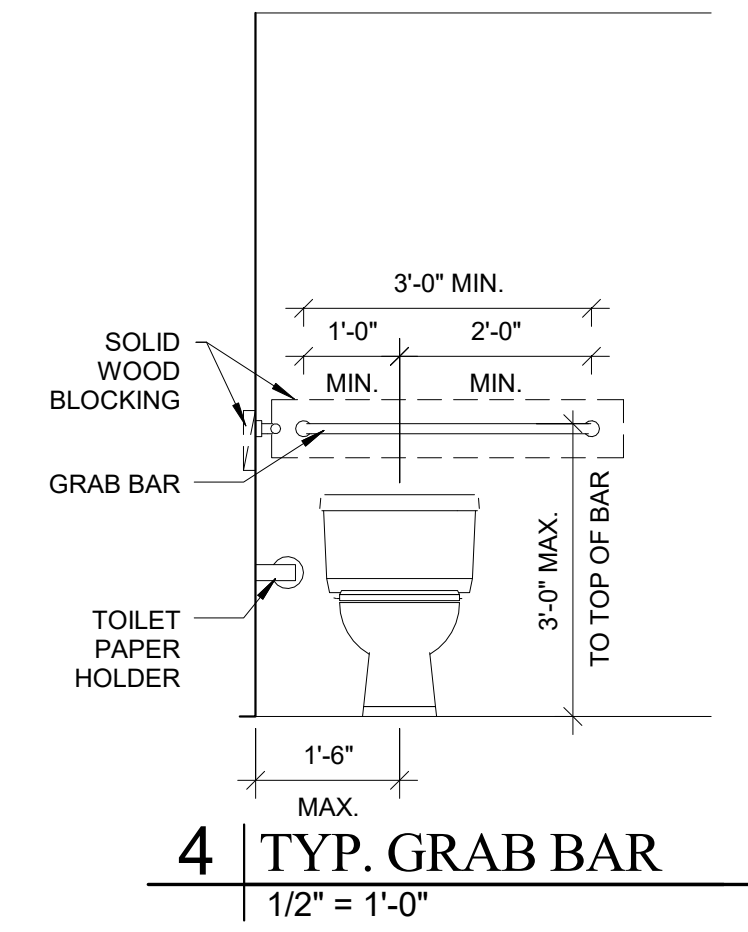

6 ADVANCED VEIN TYP EXAM CABINET
1/2" = 1'-0"

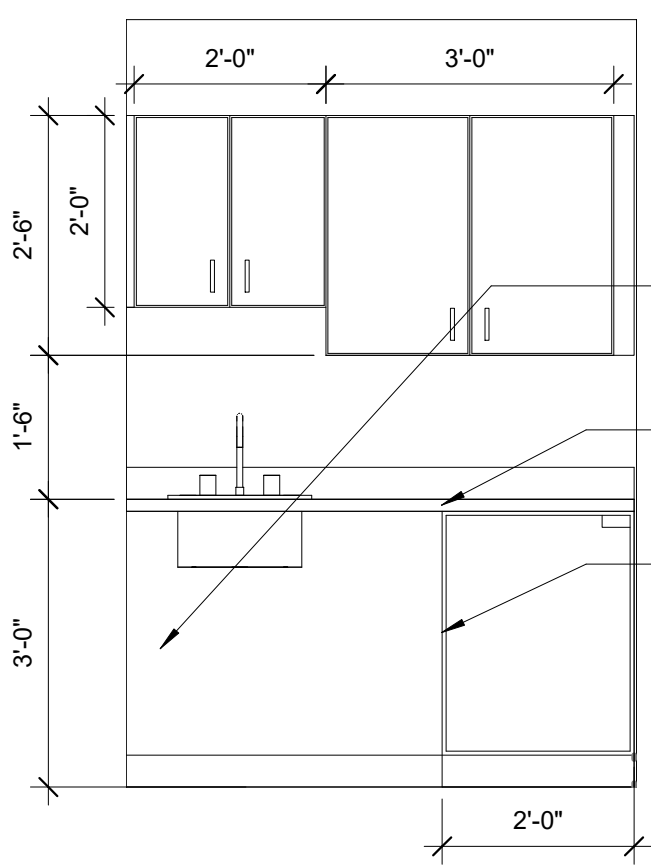
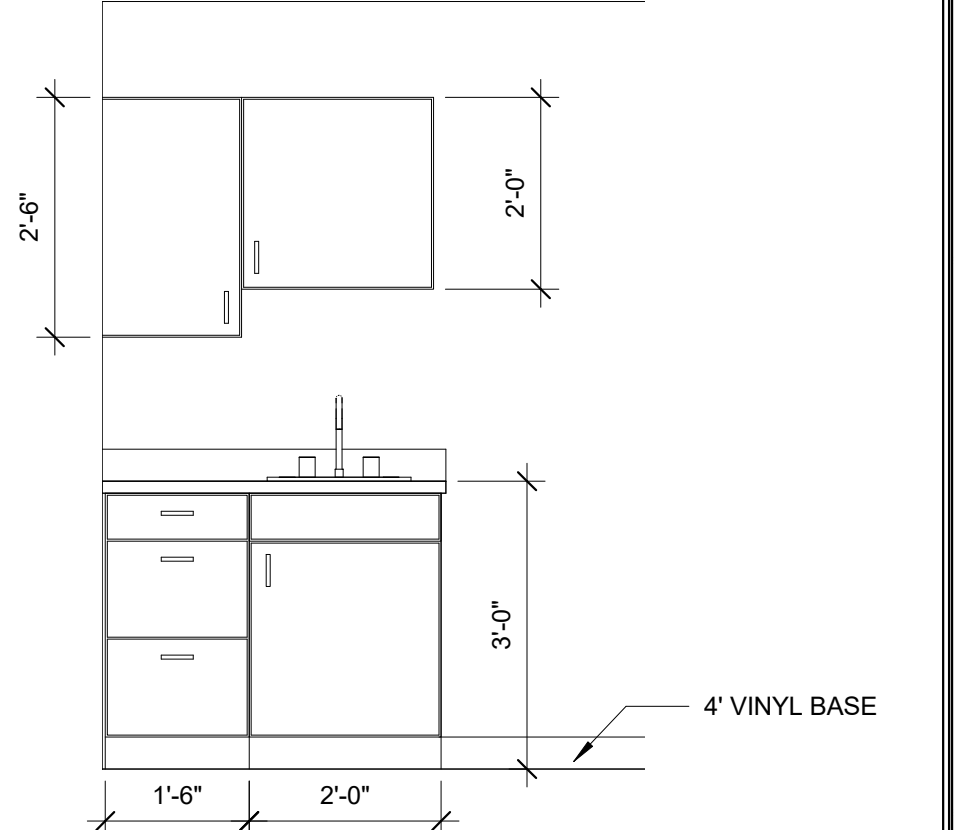

7 DIRTY 218 INT. ELEVATION
1/2" = 1'-0"

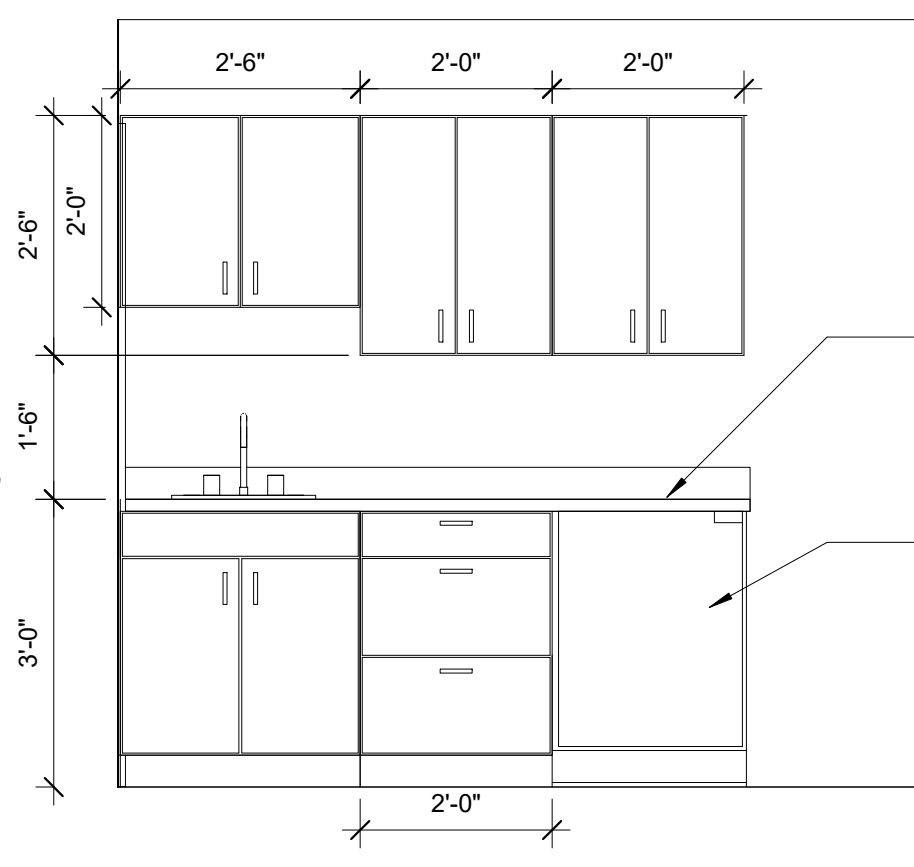

8 CLEAN 214 INT. ELEVATION
1/2" = 1'-0"

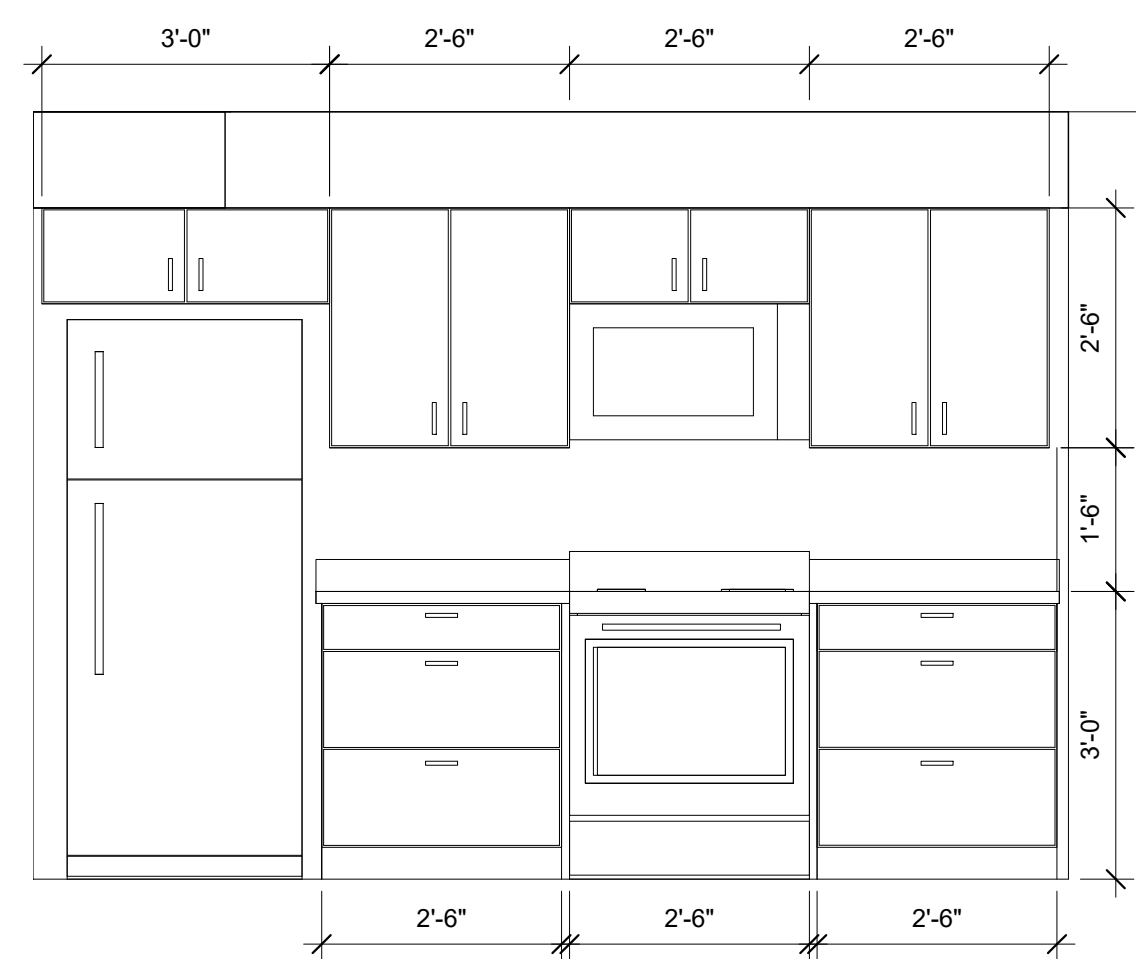

10 BASEMENT BREAK ROOM ELEVATION
1/2" = 1'-0"

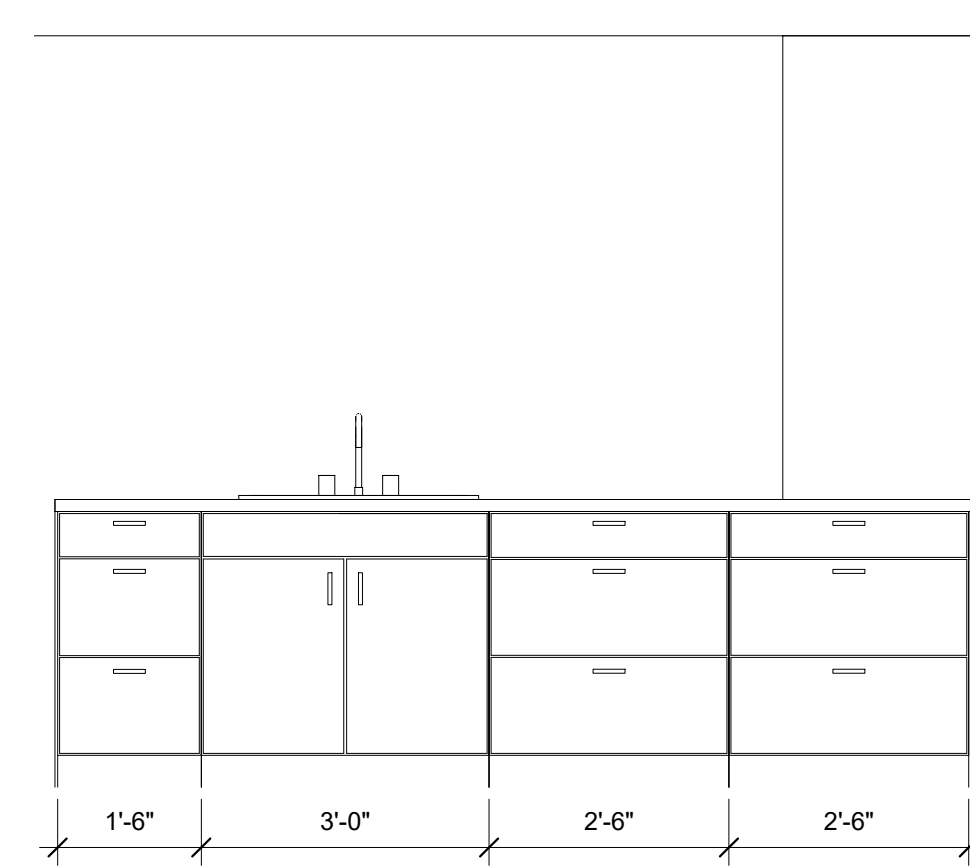

11 BASEMENT BREAK ROOM ISLAND
1/2" = 1'-0"

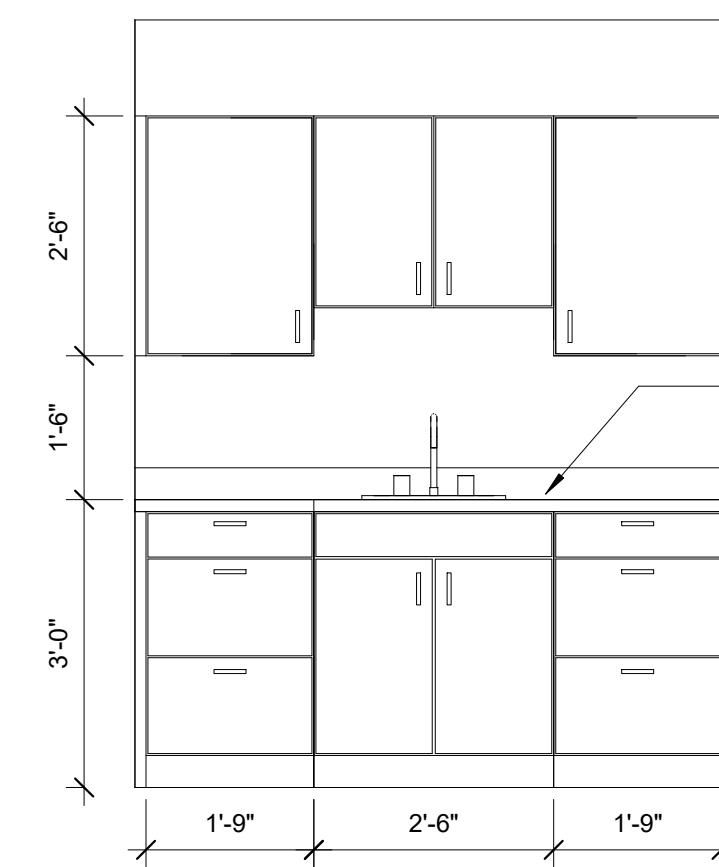

2 CLEAN 116 INT. ELEVATION
1/2" = 1'-0"

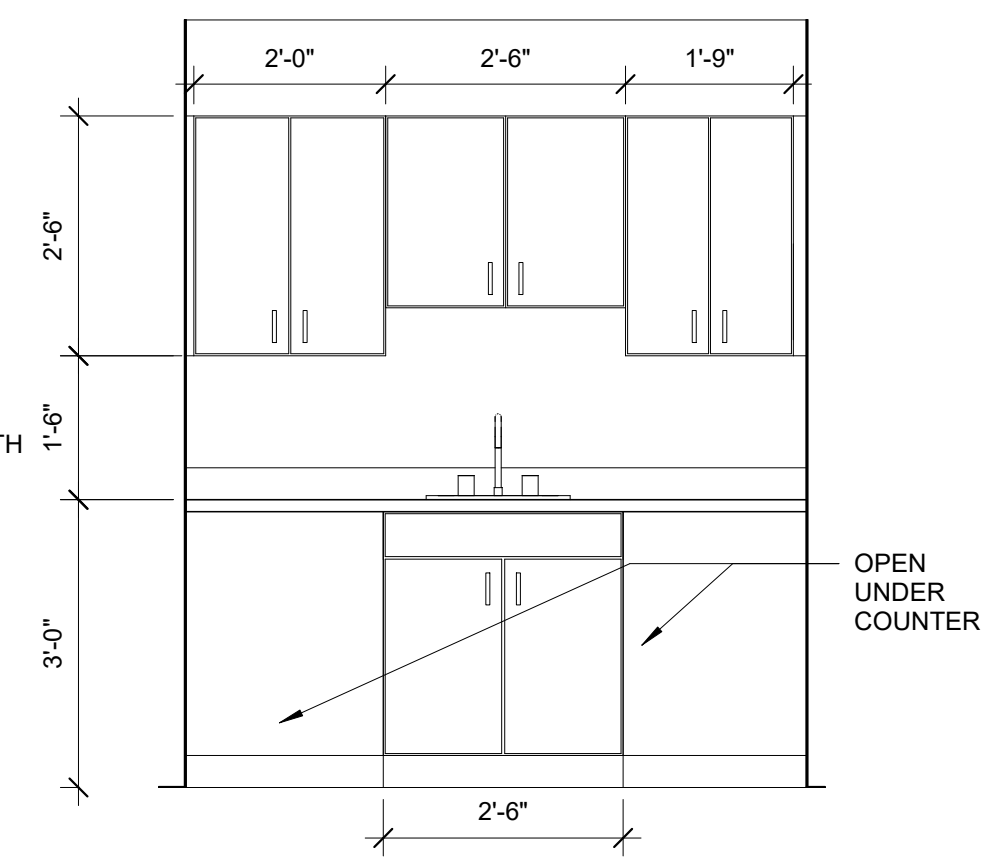

1 DIRTY 117 INT. ELEVATION
1/2" = 1'-0"

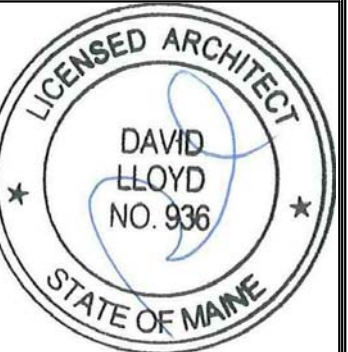

Prepared For:
Diversified Partners LLC

Consultant:
ARCHETYPE architects
48 Union Wharf Portland, Maine 04101
(207) 772-6022 ARCHETYPE@ARCHETYPEPA.COM

Project:
MEDICAL OFFICES
1945 CONGRESS STREET, PORTLAND MAINE

Revisions:
Scale: As indicated
Date: June 13, 2017
ENLARGED EXAM ROOMS

12.00