

M STAIR FRAMING DETAILS @ FRAMED SHAFT
S2.1 3/4" = 1'-0"

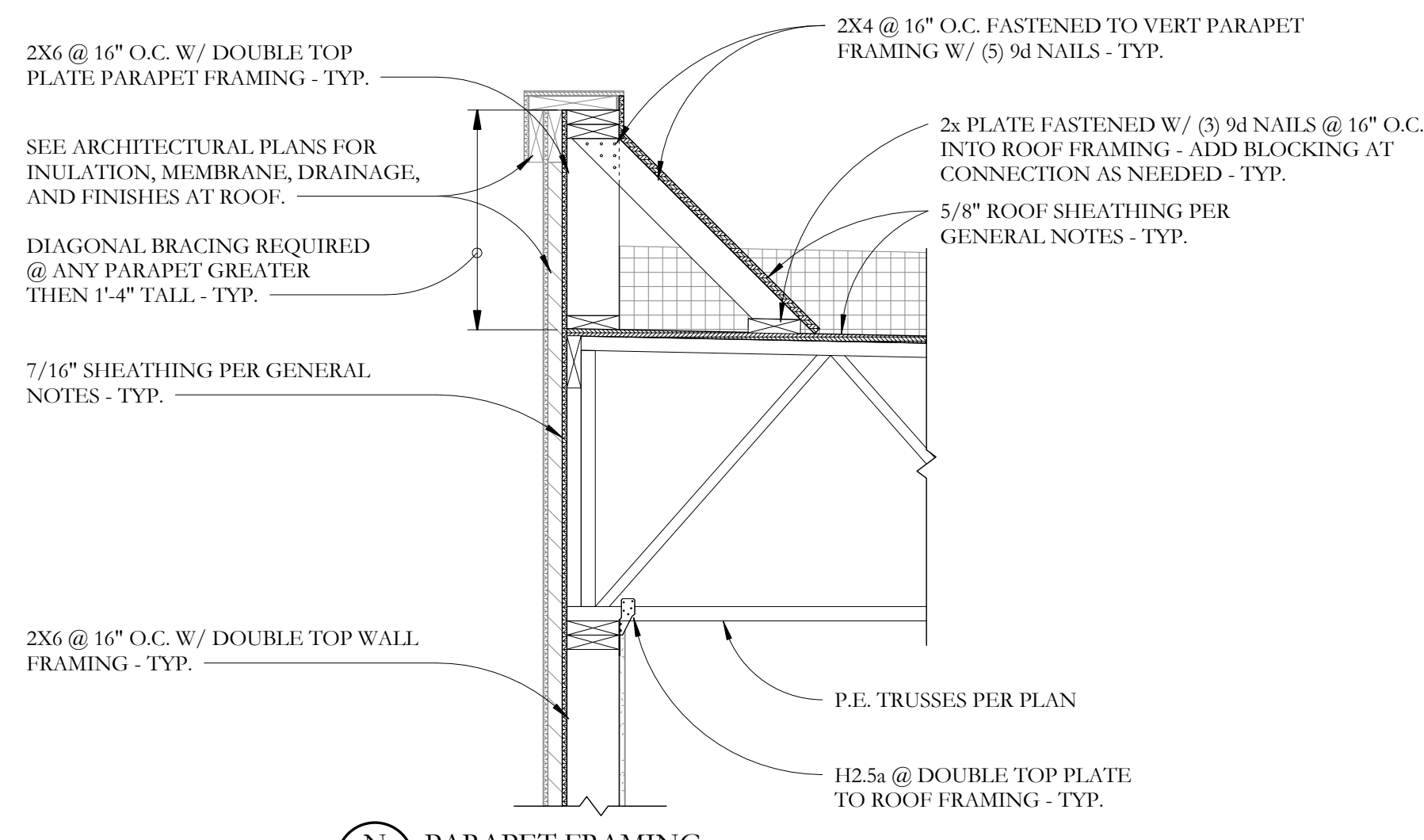

N PARAPET FRAMING
S2.1 3/4" = 1'-0"

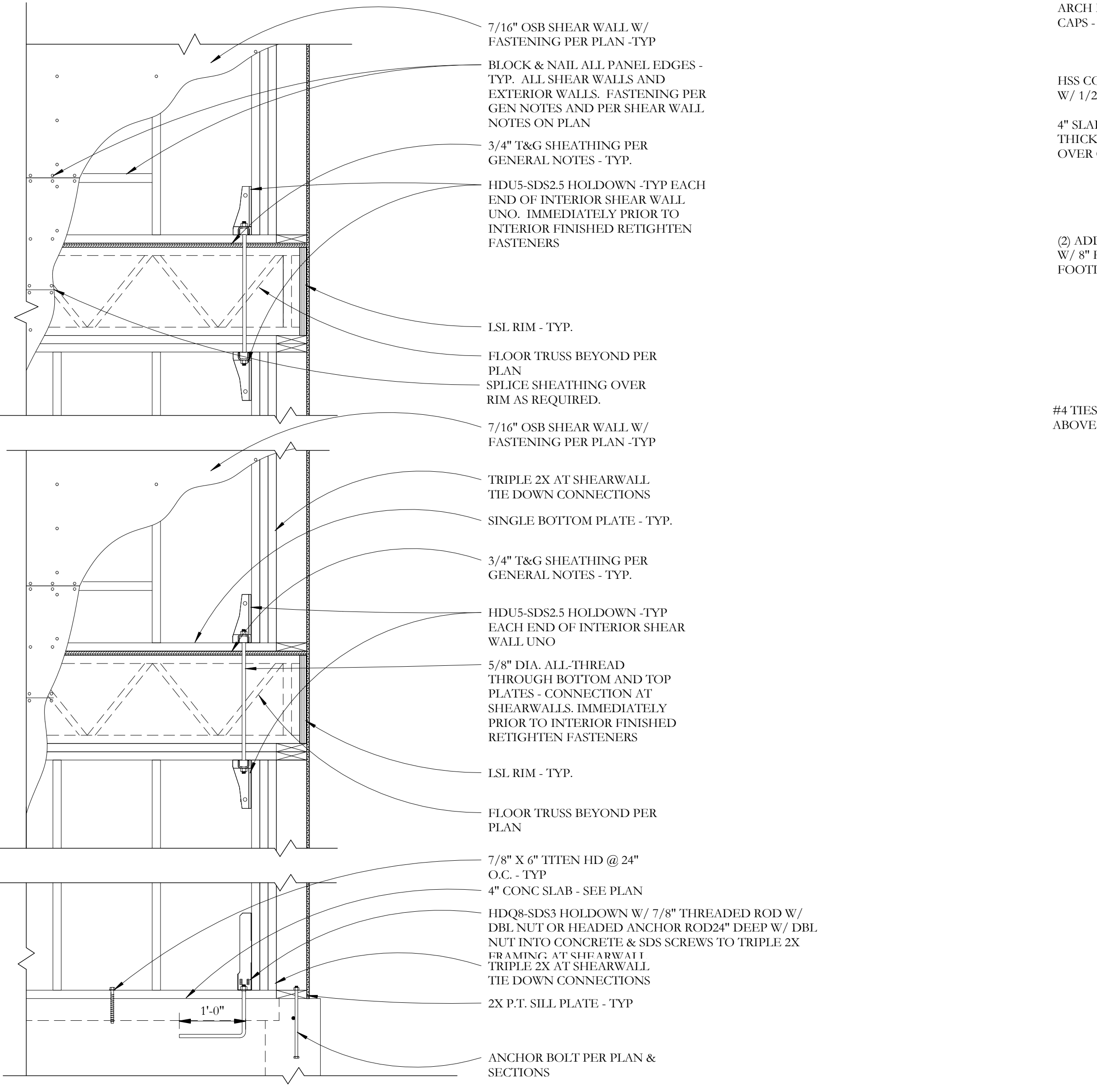

H SHEAR WALL DETAIL
S2.1 3/4" = 1'-0"

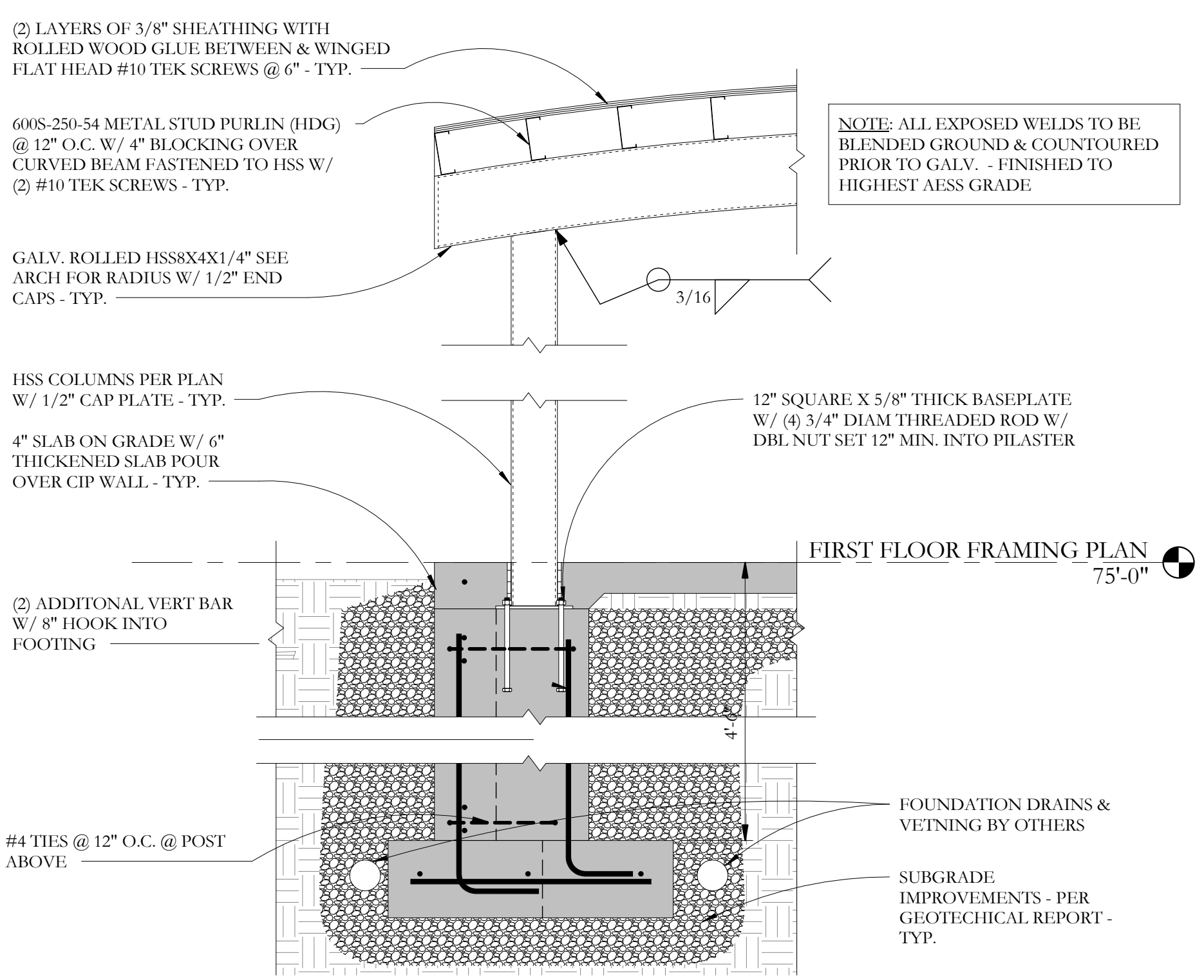

L CANOPY COLUMN
S2.1 3/4" = 1'-0"

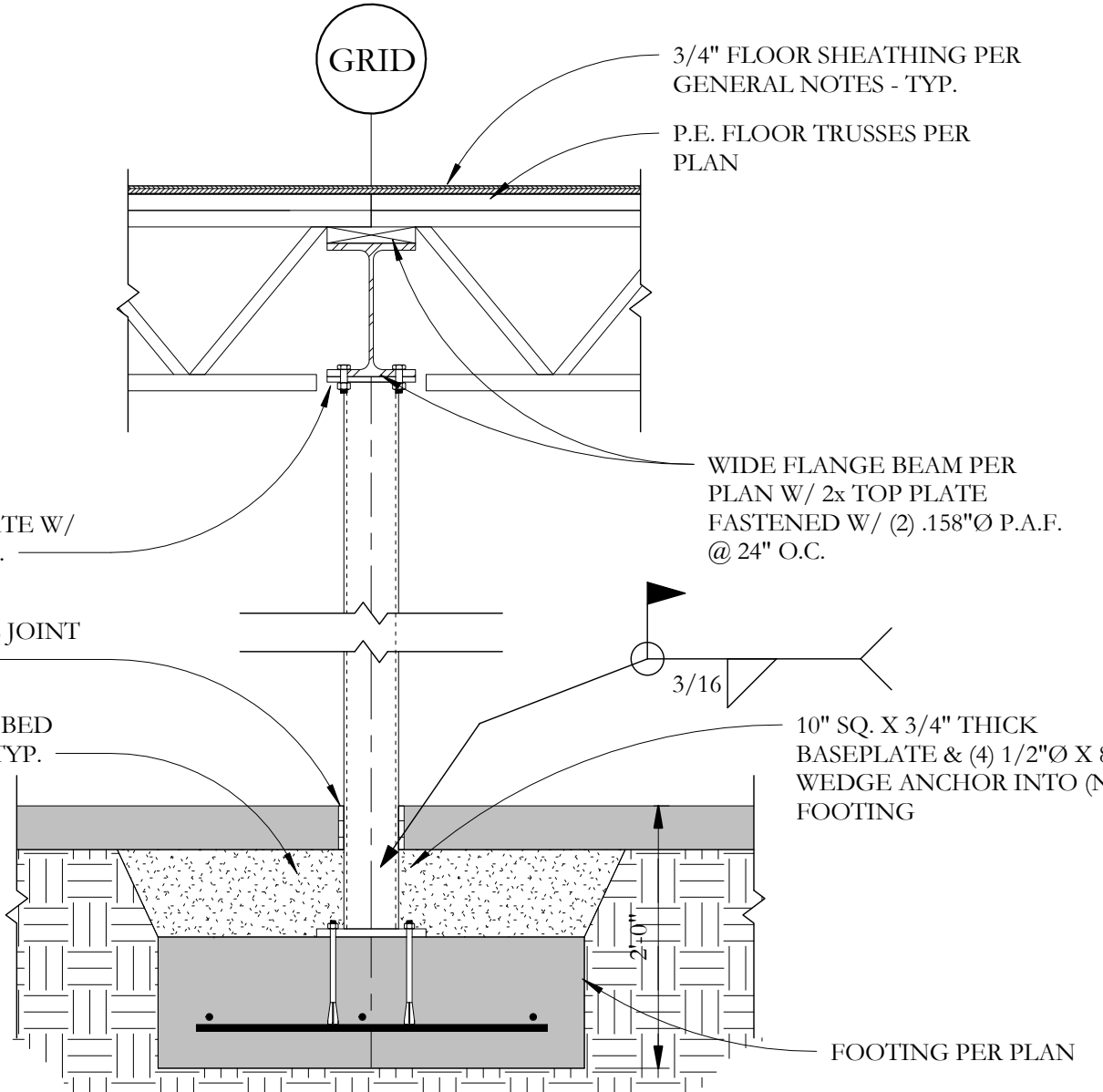

I HSS TO STEEL BEAM DETAIL
S2.1 3/4" = 1'-0"

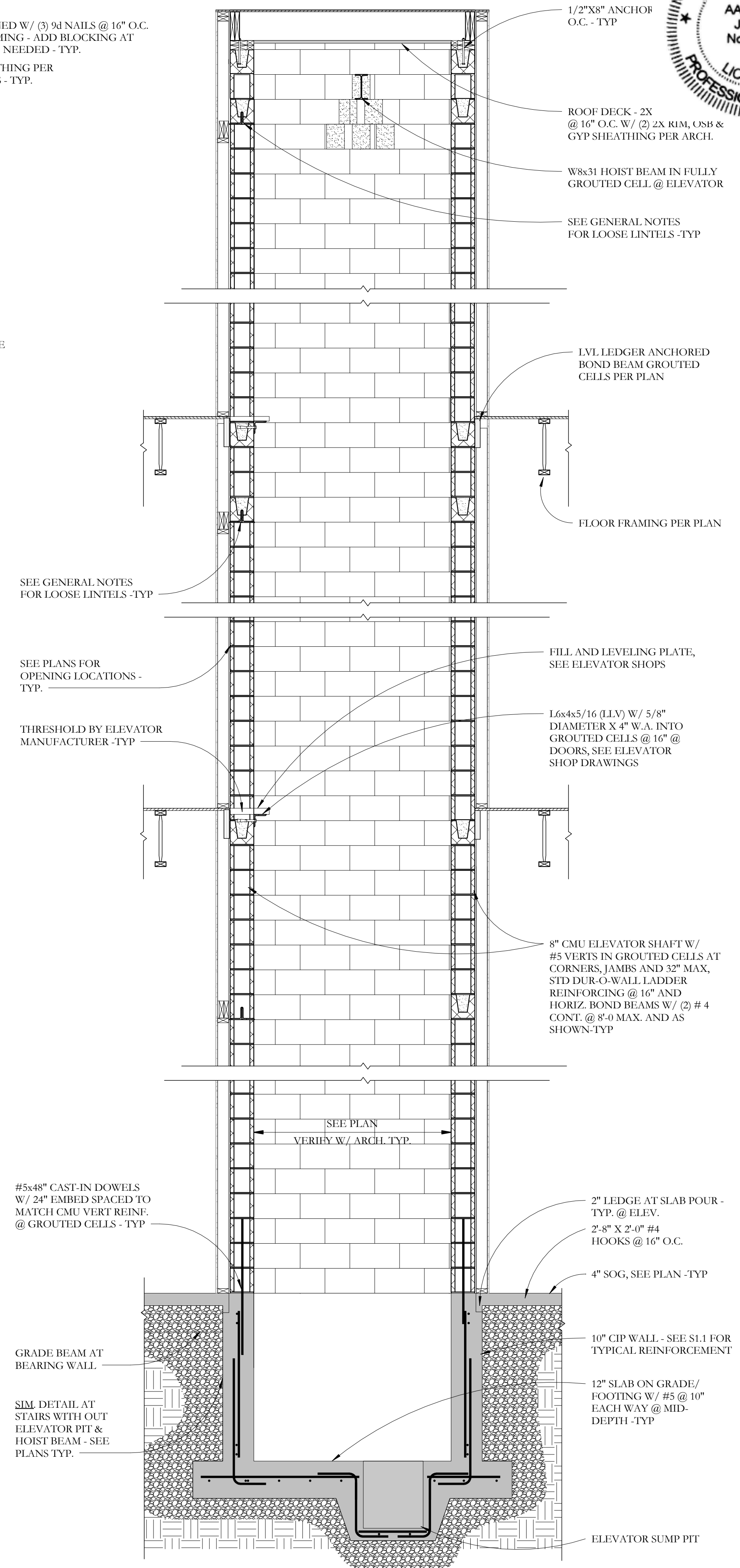

K CMU ELEVATOR SHAFT DETAIL
S2.1 1/2" = 1'-0"

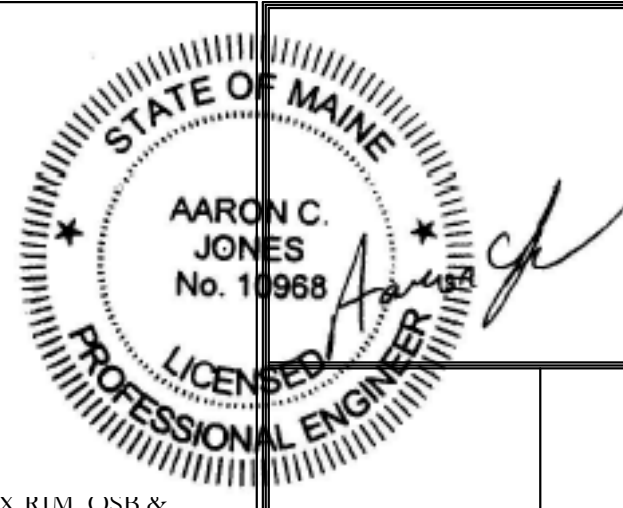

Prepared For: **Owner**

Consultant: **Structural Integrity**
77 Oak Street
Portland, ME 04101
(207) 772-0023
BUILD WITH CONFIDENCE

Architect: **ARCHETYPE architects**
48 Union Wharf Portland, Maine 04101
(207) 772-0023 ARCHETYPE@ARCHETYPE.COM

Project: **MEDICAL OFFICES**
1945 CONGRESS STREET
PORTLAND MAINE

Revisions:

Scale: As indicated
SECTIONS

Date: 27 Dec. 2016

S2.1