

UL, ULC, CSFM Listed; FM Approved;
MEA (NYC) Acceptance*

Addressable Duct Sensor Housings with TrueAlarm
Photoelectric Sensor; Available with Multiple Relay Control

Features

Compact air duct sensor housing with clear cover to monitor for the presence of smoke**

Includes factory installed TrueAlarm photoelectric smoke sensor and features:

- Individual sensor information processed by the host control panel to determine sensor status
- Digital transmission of analog sensor values via IDNet or MAPNET II, 2-wire communications
- Programmable sensitivity, consistent accuracy, environmental compensation, status testing, and monitoring of sensor dirt accumulation

Model 4098-9755:

- Basic duct sensor housing (no relay output) powered by IDNet/MAPNET II communications

Model 4098-9756:

- Duct sensor housing with supervised output for multiple remote relays; requires separate 24 VDC; includes one relay
- Relay output is under panel control
- At the panel, relay output can be activated manually or in response to a separate alarm or other input

General features:

- UL listed to Standard 268A
- Clear cover allows visual inspection
- Test ports provide functional smoke testing access with cover in place
- Mounts to rectangular ducts or round ducts; minimum size is 8" (203 mm) square or 18" (457 mm) diameter
- Magnetic test feature for alarm initiation at housing
- Optional weatherproof enclosure is available separately (refer to data sheet S4098-0032)

Diagnostic LEDs (on interface board):

- Red Alarm/Trouble LED for sensor status and communications polling display
- Yellow LED for open or shorted trouble indication of supervised relay control (4098-9756 only)

Sampling tubes (ordered separately):

- Available in multiple lengths to match duct size
- Installed and serviced with housing in place

Remote module options (ordered separately):

- Remote red status/alarm LED (2098-9808)
- Remote test station with LED (2098-9806)
- 4098-9843 remote relays (refer to page 2 for details)

* These products have been approved by the California State Fire Marshal (CSFM) pursuant to Section 13144.1 of the California Health and Safety Code. See CSFM Listing 3240-0026.241 for allowable values and/or conditions concerning material presented in this document. It is subject to re-examination, revision, and possible cancellation. Accepted for use – City of New York Department of Buildings – MEA35-93E. Additional listings may be applicable; contact your local Simplex product supplier for the latest status. Listings and approvals under Simplex Time Recorder Co. are the property of Tyco Fire Protection Products.

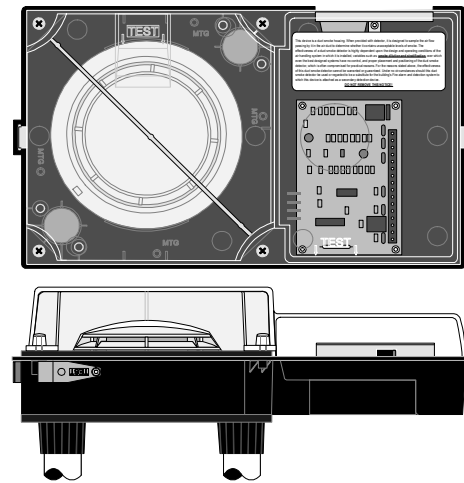

Duct Sensor Housing, Front and Bottom View

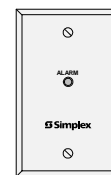

2098-9808

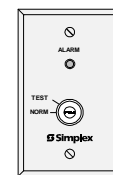

2098-9806

Remote Status/Alarm Indicator and Test Station

Introduction

Operation. Simplex® compact air duct smoke sensor housings provide TrueAlarm operation for the detection of smoke in air conditioning or ventilating ducts. Sampling tubes are installed into the duct allowing air to be directed to the smoke sensor mounted in the housing.

TrueAlarm Sensor Operation

Digital Communication of Analog Sensing.

Analog information from the sensor is digitally communicated to the control panel where it is analyzed. Sensor input is stored and tracked as an average value with an alarm or abnormal condition being determined by comparing the sensor's present value against its average.

Intelligent Data Evaluation. Monitoring each photoelectric sensor's average value provides a software filtering process that compensates for environmental factors (dust, dirt, etc.) and component aging, providing an accurate reference for evaluating new activity. The result is a significant reduction in the probability of false or nuisance alarms caused by shifts in sensitivity, either up or down.

** Please note that smoke detection in air ducts is intended to provide notification of the presence of smoke *in the duct*. It is not intended to, and will not, replace smoke detection requirements for open areas or other non-duct applications.

TrueAlarm Sensor Operation (Continued)

Control Panel Selection. Peak activity per sensor is stored to assist in evaluating specific locations. The alarm set point for each sensor is determined at the control panel, selectable as the individual application requires.

Sensor Status LED. Each sensor housing's red status LED (located on the electrical interface board) pulses to indicate communications with the panel. If the control panel determines that a sensor is in alarm, or that it is dirty or has some other type of trouble, the details are announced at the control panel and that sensor housing's status LED will be turned on steadily. During a system alarm, the control panel will control the LEDs such that an LED indicating a trouble will return to pulsing to help identify any alarmed sensors. (Remote Status/Alarm LEDs track the operation of the sensor housing LED.)

Photoelectric Sensing

TrueAlarm photoelectric sensors use a stable, pulsed infrared LED light source and a silicon photodiode receiver to provide consistent and accurate low power smoke sensing.

Duct Sensor Selection Chart

Duct Smoke Sensor Housing with Photoelectric Sensor*

| Model | Description | Compatibility |
|-----------|---|--|
| 4098-9755 | Basic Duct Sensor Housing; operating power is supplied by either IDNet or MAPNET II communications (no relay output) | Simplex fire alarm control panel models: 4100ES, 4010ES, 4008, 4010, 4100U, and legacy products 4020, 4100/4100+, and 4120. Also 2120 CDT if configured for MAPNET II, TrueAlarm operation |
| 4098-9756 | Duct Sensor Housing with supervised multiple relay output, requires separate 24 VDC fire alarm power and 4081-9008 end-of-line resistor harness; includes one 4098-9843 relay | Same as above except relay operation is not compatible with 2120 CDT; Relay output is for up to 15 total 4098-9843 Relays (additional relays are ordered separately) |

Remote LED Indicator and Test Station, Select One if Required

| Model | Description | Compatibility | Mounting |
|-----------|---|------------------------|---|
| 2098-9808 | Red LED status indicator on single-gang stainless steel plate | 4098-9755 4098-9756 | Use single gang box, 3" H x 2" W x 2" D (76 mm x 51 mm x 51 mm) |
| 2098-9806 | Test Station with keyswitch and red LED status indicator, on single-gang stainless steel plate; (turning switch to "TEST" initiates alarm for system testing) | | |

Epoxy Encapsulated Remote Relay and End-of-Line Resistor

| Model | Description | Compatibility | Location |
|-----------|---|----------------------------------|--|
| 4098-9843 | Relay; single Form C (7 A @ 120 VAC); refer to pages 3 and 4 for additional relay information; one included with 4098-9756; wiring is 18 AWG (0.82 mm ²) color coded wire leads | 4098-9756 only; connect up to 15 | Locate relays within 3 ft (1 m) of device being controlled per NFPA 72 |
| 4081-9008 | End-of-Line Resistor Harness; 10 kΩ, 1/2 W; (ref. 733-894); required to supervise remote relay coil connection | 4098-9756 | At last relay location |

* Each duct housing includes an internally mounted model 4098-9714 TrueAlarm photoelectric sensor and an exhaust tube. A correctly sized sampling tube (ordered per application) is required, refer to chart below.

Sampling Tube Selection Chart, Ordered Separately Per Duct Width, Select One

| Overall Duct Width | Tube Required | Suggested Cut Length |
|---------------------------------|------------------|---------------------------------------|
| 12" (305 mm) | 4098-9854 | 1/2" (12.7 mm) longer than duct width |
| 13" to 23" (330 mm to 584 mm) | 4098-9855 | 1/2" (12.7 mm) longer than duct width |
| 24" to 46" (610 mm to 1168 mm) | 4098-9856 | 3 in" (76 mm) longer than duct width |
| 46" to 71" (1168 mm to 1803 mm) | 4098-9857 | 3 in" (76 mm) longer than duct width |
| 71" to 95" (1803 mm to 2413 mm) | 4098-9858 | 3 in" (76 mm) longer than duct width |

Photoelectric Sensing (Continued)

Typically duct sensor applications require less sensitive settings (such as 2.5% per foot obscuration) due to the ducts being a relative dirty environment. However, the standard seven levels of TrueAlarm sensor sensitivity are available for each individual sensor, ranging from 0.2% to 3.7% per foot of smoke obscuration. Sensitivity is selected and monitored at the fire alarm control panel.

Fire Alarm Control Panel Features

- Individual smoke sensitivity selection
- Sensitivity monitoring that satisfies NFPA 72 sensitivity testing requirements
- Peak value logging allows accurate analysis for sensitivity selection
- Automatic, once per minute individual sensor calibration check verifies sensor integrity
- Automatic environmental compensation
- Smoke sensitivity is displayed in percent per foot
- Ability to display and print detailed sensor information in plain English language
- Relays of model 4098-9756 are under panel control for ON, OFF, or override

Duct Sensor Housing Detail Reference

NOTE: Refer to Installation Instructions 574-776 for additional installation detail and maintenance information.

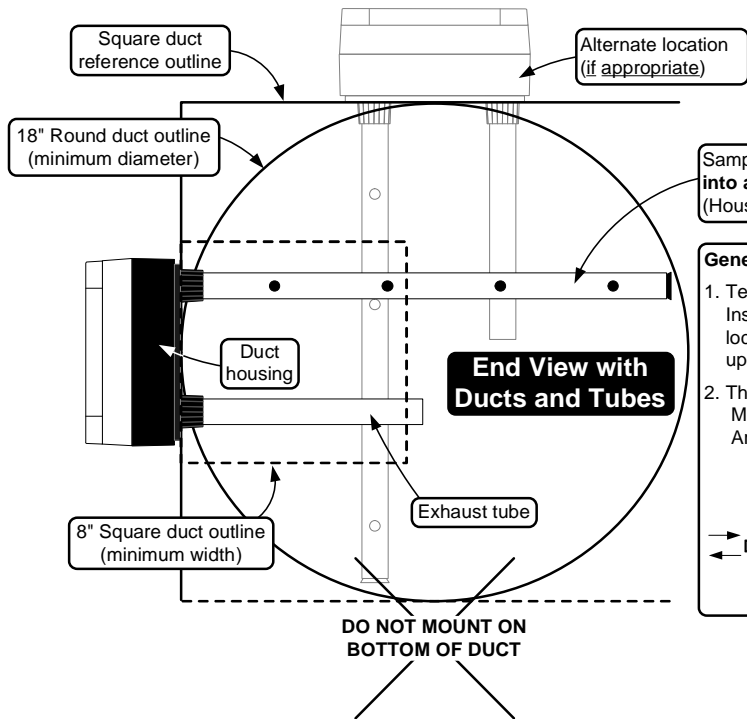
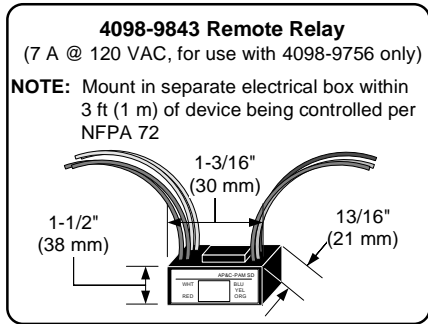
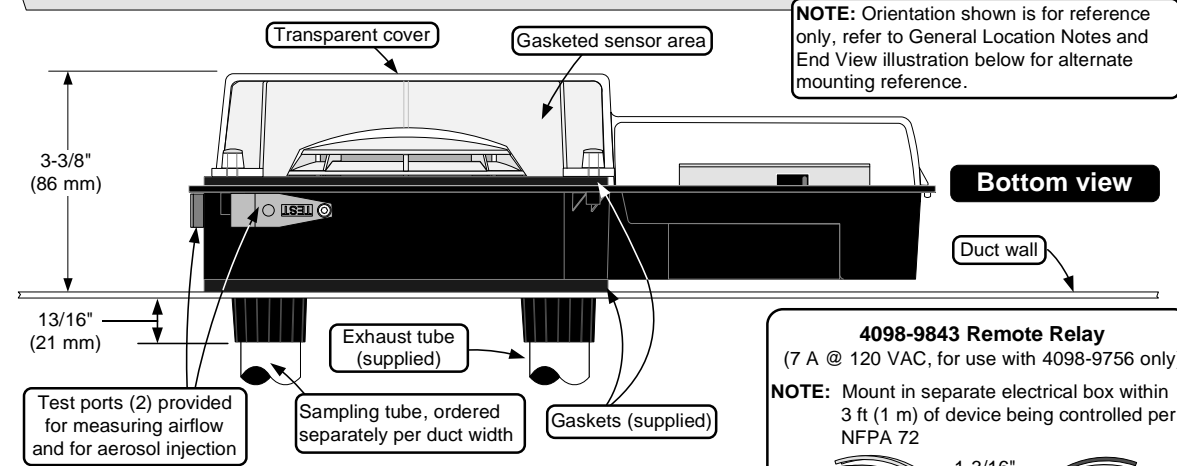
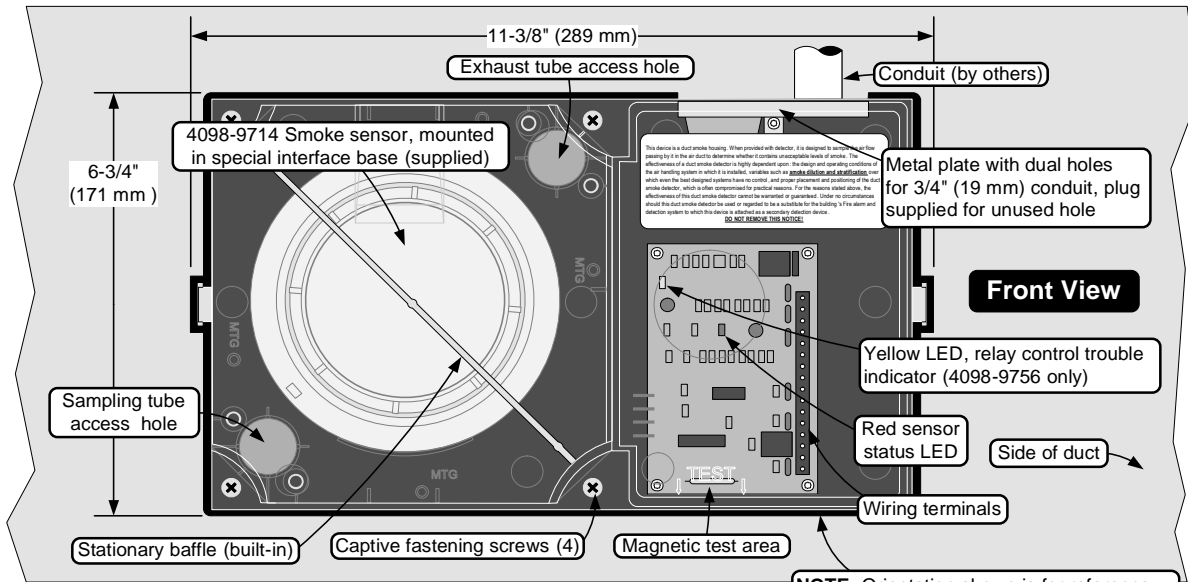

Sampling tube, keyed for proper hole alignment **with holes facing into airflow** (template is provided for proper tube installation). (Housing is shown as position 2 per note 2 below.)

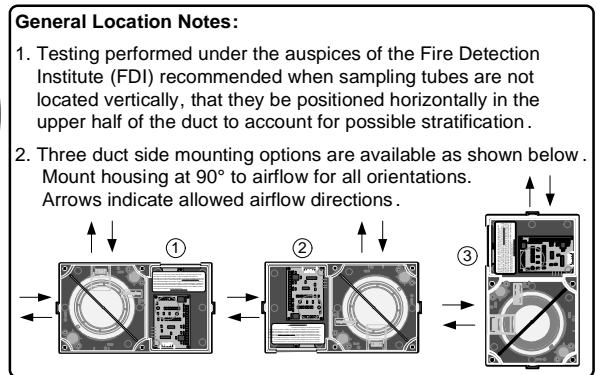

Duct Sensor Location Reference

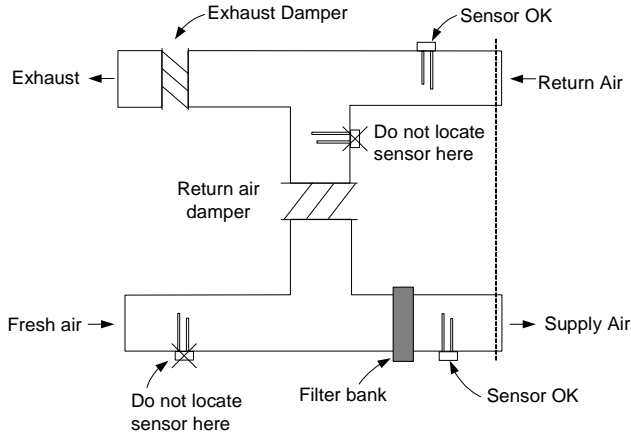

Additional Information. Refer to NFPA 90A, *Standard for the Installation of Air Conditioning and Ventilating Systems*; NFPA 72, the *National Fire Alarm and Signaling Code*; and the *NEMA Guide for Proper Use of Smoke Detectors in Duct Applications*, and Installation Instructions 574-776.

Duct Sensor Location Considerations:

1. Proper duct smoke detection location must ensure adequate airflow within the duct housing.
2. Duct air velocity rating is 300 to 4000 ft/min (91 to 1220 m/min). Pressure differential between intake and exhaust tubes is required to be between 0.015 to 1.55 inches of water (0.381 to 39.37 mm).
3. Ensure accessibility for test and service.
4. Proper Locations: downstream side of filters to detect fires in the filters; in return ducts, ahead of mixing areas; upstream of air humidifier and cooling coil.
5. Other locations and orientations may be required for proper duct smoke detection depending on duct access, system design, and duct airflow testing. Contact your local Simplex product supplier for assistance.

Locations to Avoid:

1. Where dampers closed for comfort control would interfere with airflow.
2. Next to outside air inlets (unless the intent is to monitor smoke entry from that area).
3. In return air damper branch ducts and mixing areas where airflow may be restricted.

Specifications

General Mechanical and Environmental

| | |
|------------------------------------|---|
| Air Velocity Range (linear ft/min) | 300 to 4000 ft/min (91 to 1220 m/min) |
| Sensor Sensitivity Range | 0.2% to 3.7% per foot of obscuration, selectable at host control panel |
| UL Listed Temperature Range | 32° F to 100° F (0° C to 38° C) |
| Operating Temperature Range | 32° F to 122° F (0° C to 50° C) |
| Storage Temperature Range | 0° F to 140° F (-18° C to 60° C) |
| Humidity Range | 10% to 95% RH, non-condensing |
| Wiring Connections | Terminal blocks, 18 to 12 AWG (0.82 mm ² to 3.31 mm ²) |
| Housing Color | Black base with clear cover |

Remote Status/Alarm LED and Test Station with Remote Status/Alarm LED

| | |
|--|--|
| Remote Alarm LED Current | 1.2 mA, no impact to 24 VDC alarm current (2098-9808 or 2098-9806) |
| Test Station Keyswitch Current | 3.3 mA, no impact to 24 VDC alarm current (2098-9806) |
| Remote Alarm LED and Test Station Distance | 250 ft (76 m) maximum |

Addressable Operation

| | |
|---------------------|--|
| Data Communications | IDNet or MAPNET II communications, auto-select, one address per housing; provides operating power to model 4098-9755 |
|---------------------|--|

Model 4098-9756 with Supervised Multiple Relay Control, Requires Separate Fused 24 VDC from Fire Alarm Power Supply

| | |
|--|--|
| Input Voltage | 18-32 VDC (24 VDC nominal) |
| Standby Current | 3 mA @ 24 VDC |
| Alarm Current | 15 mA @ 24 VDC; add 15 mA for each 4098-9843 relay |
| Supervised Remote Relay Control Output | For use with 4098-9843 relay only, quantity of 15 maximum; distance of 500 ft (152 m) maximum; requires 4081-9008 (ref. 733-894) 10 kΩ, 1/2 W end-of-line resistor |

4098-9843 Relay Output Ratings, Single Form C, use with Model 4098-9756 Only

| | |
|-------------------|---|
| Coil Current | 15 mA @ 24 VDC, up to 15 maximum per relay control output |
| Relay Contacts | 7 A at 0.35 PF @ 28 VDC & 120 VAC; 250 μA @ 5 VDC |
| Location Distance | 500 ft (152 m) maximum to relay coils; locate relays within 3 ft (1 m) of device being controlled per NFPA 72 |

TYCO, SIMPLEX, and the product names listed in this material are marks and/or registered marks. Unauthorized use is strictly prohibited. NFPA 72 and National Fire Alarm and Signaling Code are registered trademarks of the National Fire Protection Association (NFPA).