

GENERAL NOTES

- 1. THESE DRAWINGS DEPICT GENERAL LOCATIONS OF LIFE SAFETY EQUIPMENT & FIELD DEVICES. EXACT ROUTING OF CONDUITS TO BE DETERMINED IN THE FIELD BY THE INSTALLING CONTRACTOR TO SUIT CONDITIONS. ALL CHANGES SHALL BE CLEARLY INDICATED ON THE RECORD DRAWINGS.
2. SHOULD ANY CONDITIONS EXIST THAT DIFFER FROM WHAT IS INDICATED ON THESE DRAWINGS WHICH CAUSE MAJOR DEVIATIONS IN THE WORK SHOWN, THE CONTRACTOR SHALL CONTACT SIMPLEXGRINNELL IN A TIMELY MANNER SO AS NOT TO IMPAIR THE CONSTRUCTION SCHEDULE.
3. CONTRACTOR IS RESPONSIBLE FOR MAKING AND OBTAINING APPROVAL FOR ALL NECESSARY ADJUSTMENTS IN CIRCUITING AS REQUIRED TO ACCOMMODATE THE RELOCATION OF EQUIPMENT AND/OR DEVICES WHICH ARE AFFECTED BY ANY AUTHORIZED CHANGE. ALL CHANGES SHALL BE CLEARLY INDICATED ON THE RECORD DRAWINGS.
4. A STAMPED SET OF APPROVED FIRE ALARM DRAWINGS SHALL BE AT THE JOB SITE AND SHALL BE USED FOR INSTALLATION.
5. THE POWER CIRCUIT TO THE FACP AND TO THE FIRE ALARM POWER SUPPLIES SHALL BE ON A DEDICATED 120V, 20A BRANCH CIRCUIT BREAKER, AND SHALL HAVE A RED MARKING, LOCK-ON PROVISION AND SHALL BE IDENTIFIED AS "FIRE ALARM CIRCUIT CONTROL." THE LOCATION OF THE CIRCUIT DISCONNECT MEANS (CIRCUIT BREAKER) SHALL BE PERMANENTLY IDENTIFIED AT THE FIRE ALARM CONTROL UNIT.
6. UPDATE THE AS-BUILT DRAWING SET DAILY WITH JOB PROGRESS. RETURN THE AS-BUILT DRAWING SET TO SIMPLEXGRINNELL NO LATER THAN 7 DAYS AFTER FINAL TEST.
7. THE CONTRACTOR WILL MAINTAIN ALL AREAS OF THE BUILDING IN A NEAT AND WORKMAN LIKE MANNER.
8. DO NOT APPLY POWER EXCEPT IN THE PRESENCE OF A FACTORY TRAINED SIMPLEXGRINNELL TECHNICAL REPRESENTATIVE.
9. ANY SMOKE DETECTOR HEAD INSTALLED BEFORE THE BUILDING IS CLEANED AND ACCEPTED SHALL BE COVERED TO PROTECT FROM DUST. ANY FALSE ALARMS DUE TO DIRT CONTAMINATED HEADS SHALL BE THE RESPONSIBILITY OF THE FIRE ALARM INSTALLER.
10. THE FIRE ALARM INSTALLER WILL MAINTAIN THE FIRE RESISTANCE INTEGRITY OF ALL WALL, CEILING, AND ROOF ASSEMBLIES ANY TIME THAT WORK IS NOT ACTIVELY BEING PERFORMED.
11. INSTALLATION OF DEVICES SHALL BE IN ACCORDANCE WITH MANUFACTURER'S INSTRUCTIONS. POWER LIMITED AND NON-POWER LIMITED FIELD WIRING MUST BE INSTALLED WITHIN THE FACP ENCLOSURE IN ACCORDANCE WITH MANUFACTURER'S INSTRUCTIONS AND NEC.
12. ALL WIRING SHALL BE INSTALLED ACCORDING TO NFPA 70 (NEC).
13. FIRE ALARM CIRCUITS SHALL BE IDENTIFIED IN ACCORDANCE WITH APPROPRIATE SECTION OF NEC 760. MARK ALL FIRE ALARM WIRES IN ACCORDANCE WITH NEC 760 SECTIONS FOR POWER LIMITED AND NON-POWER LIMITED WIRE.
14. FIRE ALARM CABLE INSTALLED IN DUCTS, PLENUM, AND OTHER SPACES USED FOR ENVIRONMENTAL AIR SHALL BE TYPE FPLP.
15. FIRE ALARM CABLE INSTALLED IN THE VERTICAL RUNS AND PENETRATE MORE THAN ONE FLOOR OR CABLES INSTALLED IN VERTICAL RUNS IN SHAFTS SHALL BE TYPE FPLR.
16. FIRE ALARM CABLE INSTALLED IN UNDERGROUND CONDUIT OR OTHER WET LOCATIONS SHALL BE UL LISTED FOR WET LOCATIONS.
17. FIRE ALARM CIRCUITS EXTENDING BEYOND ONE BUILDING AND RUN OUTDOOR SHALL BE INSTALLED IN ACCORDANCE WITH NFPA 70 ARTICLES 760, 770, 725 AND 800 WHERE APPLICABLE.
18. ALL WIRING, INCLUDING SHIELDS MUST BE DRY AND FREE OF SHORTS AND GROUNDS.
19. ALL SHIELDED WIRE MUST HAVE SHIELD CONTINUITY AT FULL LENGTH OF THE WIRE.
20. ONLY SYSTEM WIRING CAN BE RUN IN THE SAME CONDUIT.
21. 120VAC IS NOT PERMITTED IN THE SAME CONDUIT WITH LOW VOLTAGE WIRING.
22. MAINTAIN 40 PERCENT CONDUIT FILL RATIO AS PER NEC REQUIREMENTS.
23. EXISTING CONDUITS MAY BE USED BY THE INSTALLATION CONTRACTOR AS DEEMED NECESSARY. HOWEVER, ANY EXISTING CONDUIT WILL BE USED ONLY IF CONDUITS MEET CURRENT STANDARDS AND CODES. SIMPLEXGRINNELL MAKES NO STATEMENTS WRITTEN OR VERBAL, AS TO THE CONDITION OF EXISTING CONDUITS.

SYSTEM DESCRIPTION / SCOPE OF WORK

OCCUPANCY TYPE: B BUSINESS GROUP
SPRINKLER PROTECTION: BUILDING IS FULLY SPRINKLED
MODIFY EXISTING FIRE ALARM SYSTEM: PROVIDING NEW DEVICES, RELOCATE AND DEMO EXISTING DEVICES AS SHOWN ON DRAWINGS.
ALL NEW WIRING TO BE CLASS A.
THE EXISTING FIRE ALARM SYSTEM SHALL NOT BE DISCONNECTED OR TAKEN OUT OF SERVICE WITHOUT WRITTEN PERMISSION FROM THE OWNER. IT IS THE CONTRACTOR'S RESPONSIBILITY TO COORDINATE WITH THE OWNER THE TIMING OF ANY EXISTING FIRE ALARM SYSTEM DEMOLITION WORK.

FIRE ALARM APPLICABLE CODES & STANDARDS

FIRE PREVENTION CODE (NFPA 1), 2006 EDITION
NATIONAL ELECTRIC CODE (NFPA 70), 2011 EDITION
ELEVATOR CODE ASME A.17.1, 2013

JURISDICTIONS WITHIN THE STATE MAY HAVE AMENDMENTS TO THE STATE ADOPTED CODE. CHECK WITH THE LOCAL JURISDICTION AUTHORITY FOR MORE DETAILS.

SYMBOL KEY

Table with columns: SYMBOL, DESCRIPTION, MODEL#, COMMONLY USED BACKBOX, REFER TO DATA SHEET FOR OTHER OPTIONS. Includes symbols for NAC panel, smoke sensor, addressable module, relay, speaker, signal, and junction box.

WIRE SCHEDULE

FIRE ALARM WIRE LIST table with columns: CIRCUIT DESCRIPTION, RISER RATED: FPLR, SINGLE CONDUCTOR (THHN, TFFN), PLENUM RATED: FPLP. Lists various circuits like door holder, relay, visual, and zone circuits.

THE CABLES SPECIFIED HERE ARE FOR REFERENCE OF REQUIRED ELECTRICAL CHARACTERISTICS AS WELL AS CODE REQUIREMENTS. ALTERNATE SUPPLIERS MAY BE SUBSTITUTED PROVIDING EQUIVALENT CHARACTERISTICS ARE MAINTAINED. ITEMS SUCH AS CAPACITANCE BETWEEN CONDUCTORS AND WIRE GAUGE CAN BE CRUCIAL TO THE CIRCUIT DESIGN OF THIS SYSTEM INSTALLATION.
REFERENCE https://www.onixter.com/customer/tycofs FOR SG ANIXTER CABLE DATA

ABBREVIATIONS LEGEND

- AC = ABOVE CEILING
C = CEILING MOUNTED
E = EXISTING TO REMAIN
RC = EXISTING TO REMOVE AND COVER
RD = EXISTING DEVICE TO BE RELOCATED
RL = RELOCATED DEVICE
RR = REMOVE EXISTING AND REPLACE W/NEW
WP = WEATHERPROOF
XP = EXPLOSION PROOF
H = HIGH HUMIDITY
AFF = ABOVE FINISHED FLOOR
AHJ = AUTHORITY HAVING JURISDICTION
ALM = ALARM
ANN = ANNUNCIATOR
BMS = BUILDING MANAGEMENT SYSTEM
CBQ = CALIFORNIA BUILDING CODE
CD = (eg. 15CD) CANDELA
CSFM = CALIFORNIA STATE FIRE MARSHAL
DET = DETECTOR
DGP = DATA GATHERING PANEL
EOL = END OF LINE
EPO = EMERGENCY POWER OFF
FACP = FIRE ALARM CONTROL PANEL
FATC = FIRE ALARM TERMINAL CABINET
FBO = FURNISHED BY OTHERS
FCZ = FIRE COMMAND CENTER
FAA = FIRE ALARM ANNUNCIATOR
FTR = FIRE ALARM TRANSPONDER
FSD = FIRE SMOKE DAMPER
HT = HEIGHT
HVAC = HEATING, VENTILATION, & AIR CONDITIONING
IMS = INFORMATION MANAGEMENT SYSTEM
MAX = MAXIMUM
MIN = MINIMUM
N/A = NOT APPLICABLE
NAC = NOTIFICATION APPLIANCE CIRCUIT EXTENDER
NDU = NETWORK DISPLAY UNIT
NEC = NATIONAL ELECTRICAL CODE
NFPA = NATIONAL FIRE PROTECTION ASSOCIATION
NIC = NOT IN CONTRACT
NPU = NETWORK PROCESSING UNIT
NTS = NOT TO SCALE
PAP = PRE-ACTION PANEL
SCC = STATUS COMMAND CENTER
SLC = SIGNALING LINE CIRCUIT
SMK = SMOKE
SUPV = SUPERVISORY
TAC = TRUE/ALERT ADDRESSABLE CONTROLLER
TREL = TROUBLE
TSL = TAMPER SWITCH
TYP = TYPICAL
UON = UNLESS OTHERWISE NOTED
VCC = VOICE COMMAND CENTER
VT = VALVE TAMPER
WF = WATER FLOW
W = (eg. 1/2W) WATT
W/ = WITH
W/O = WITH OUT

DEVICE ADDRESSING LEGEND

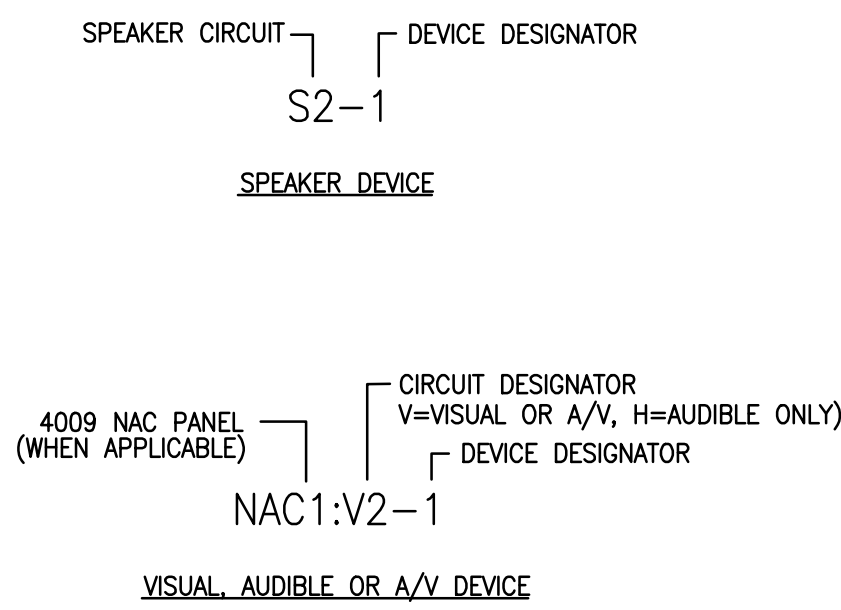

SEQUENCE OF OPERATION

Large grid table for Sequence of Operation. Columns include SYSTEM INPUTS (A-S), CONTROL UNIT ANNUNCIATION, NOTIFICATION, FIRE SAFETY CONTROL, SYSTEM OUTPUTS, and REMARKS. Rows list various system events like smoke sensor, manual pull station, fire pump running, etc.

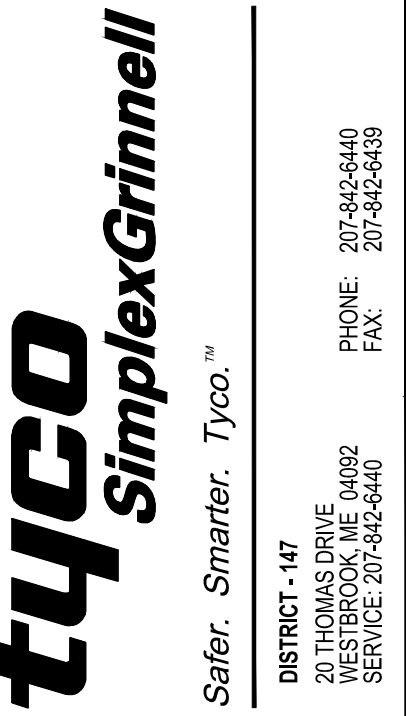

tyco Smarter. Tyco.™
SIMPLETECH
20 THOMAS DRIVE
WEST BROOKFIELD, MA 01581
PHONE: 207-868-8440
FAX: 207-868-4885

UNUM H01 INTERIOR RENOVATIONS
UNUM H01 INTERIOR RENOVATIONS
2211 CONGRESS STREET
PORTLAND, ME 04102

Table with columns: ISSUE NO., MARK, DATE, CAD, CHK, DESCRIPTION. Used for tracking drawing revisions.

DRAWN BY: M.DESIATA
CHECKED BY: S.KALAFARSKI
ISSUE DATE: 3/12/15
JOB #:
PROJECT #: 147-983293301
SIMPLEXGRINNELL © 2015

SYSTEM: FIRE ALARM SYSTEM
SHEET:
GENERAL INFORMATION
FA-002

IMPORTANT NOTICE: THIS DRAWING IS THE PROPERTY OF SIMPLEXGRINNELL AND IS NOT TO BE REPRODUCED OR TRANSMITTED IN ANY FORM OR BY ANY MEANS, ELECTRONIC OR MECHANICAL, INCLUDING PHOTOCOPYING, RECORDING, OR BY ANY INFORMATION STORAGE AND RETRIEVAL SYSTEM, WITHOUT THE WRITTEN PERMISSION OF SIMPLEXGRINNELL. THE USER AGREES TO THE FOLLOWING TERMS AND CONDITIONS: THE DRAWING IS THE PROPERTY OF SIMPLEXGRINNELL AND IS NOT TO BE REPRODUCED OR TRANSMITTED IN ANY FORM OR BY ANY MEANS, ELECTRONIC OR MECHANICAL, INCLUDING PHOTOCOPYING, RECORDING, OR BY ANY INFORMATION STORAGE AND RETRIEVAL SYSTEM, WITHOUT THE WRITTEN PERMISSION OF SIMPLEXGRINNELL.