

SINK OR VANITY
SCALE: 1/2" = 1'-0"

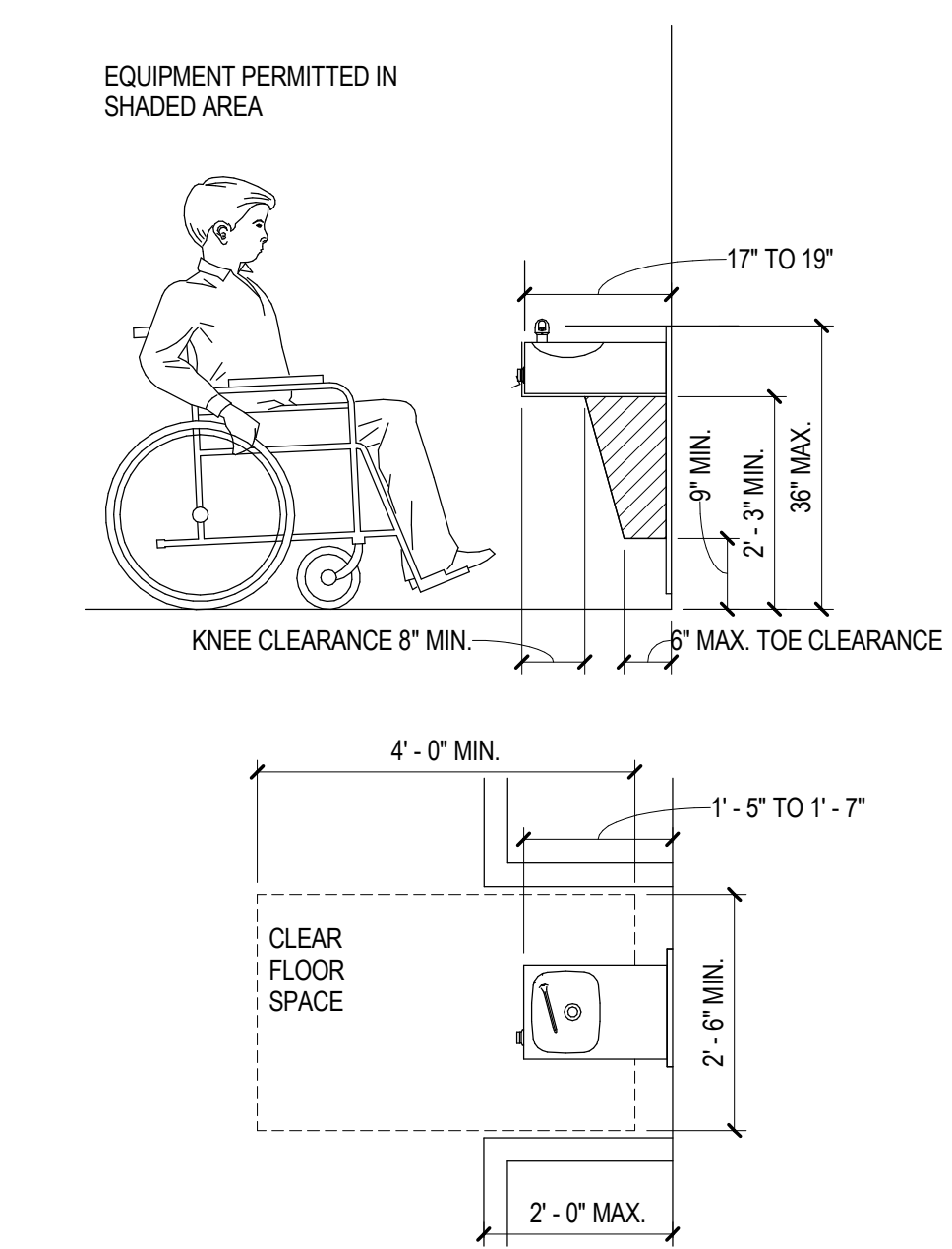

DRINKING FOUNTAIN
SCALE: 1/2" = 1'-0"

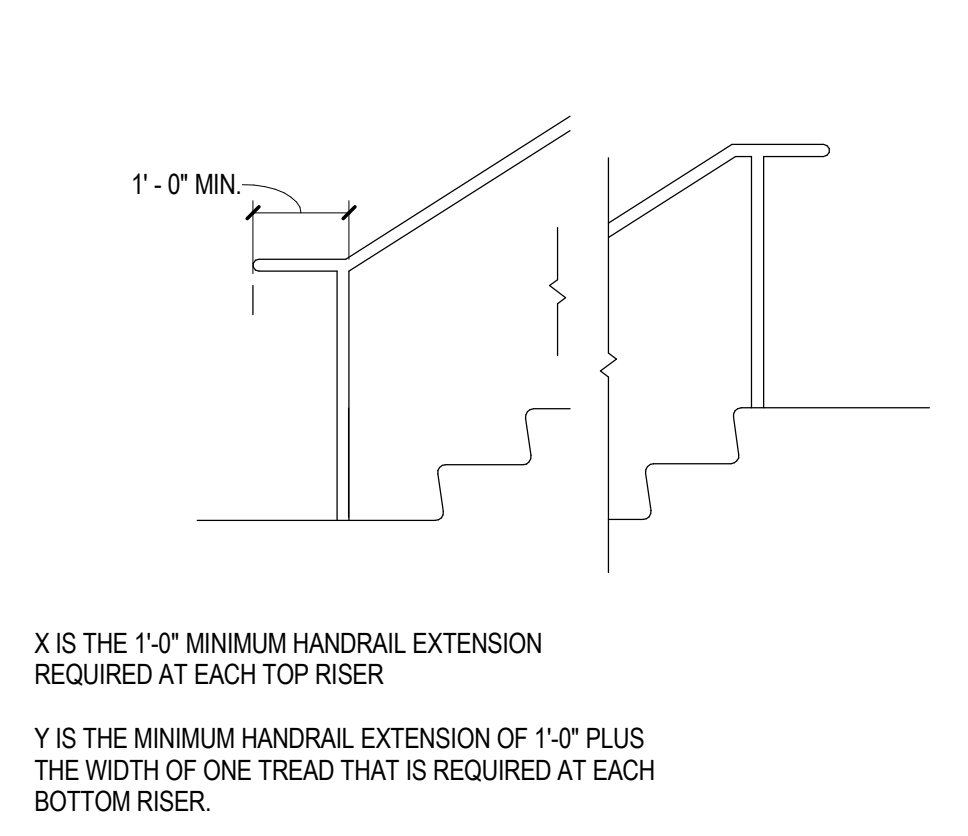

HANDRAIL EXTENSIONS
SCALE: 1/2" = 1'-0"

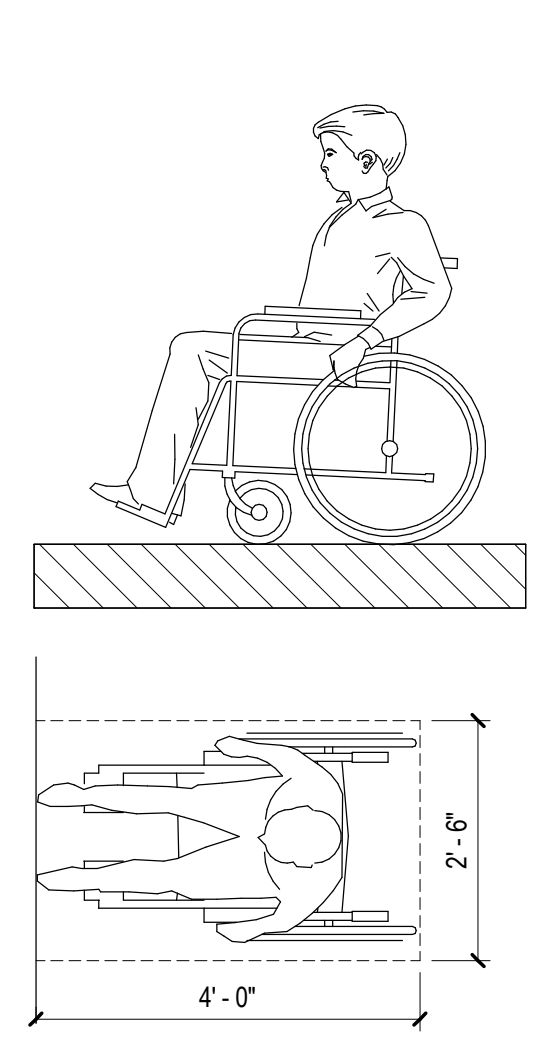

REACH RANGES/CLR FLR
SCALE: 1/2" = 1'-0"

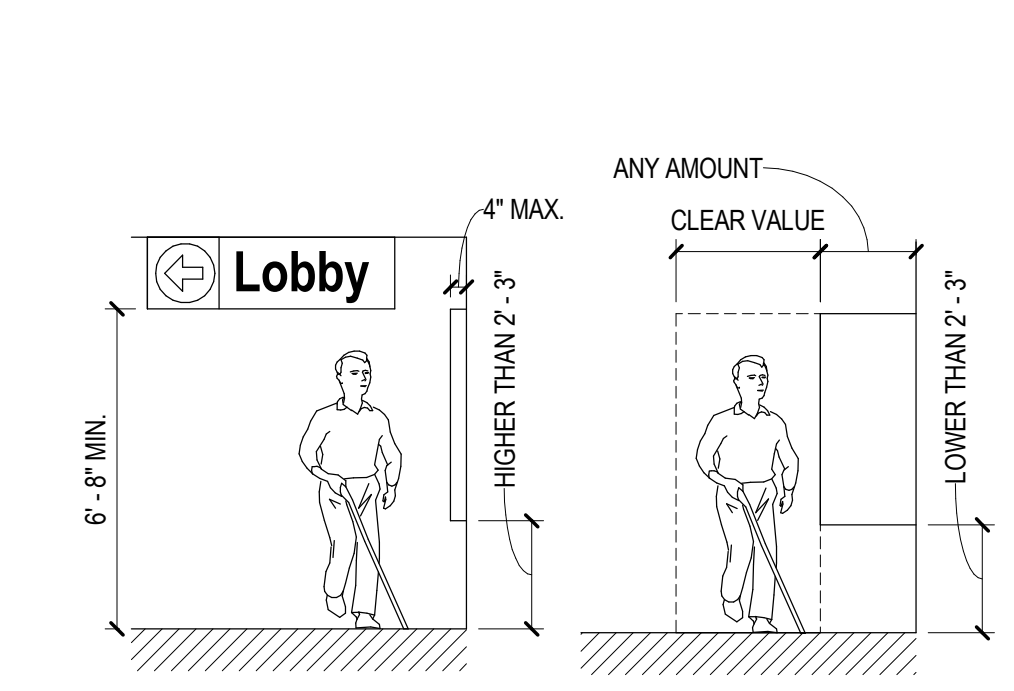

PROTRUDING OBJECTS
SCALE: 1/4" = 1'-0"

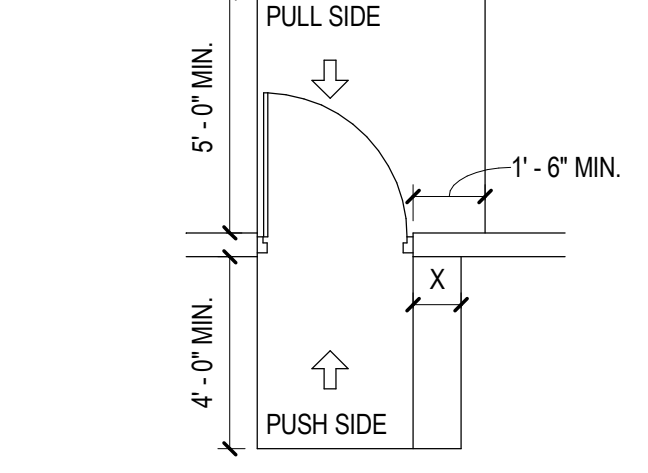

NOTE: X = 1'-0" IF DOOR HAS BOTH A CLOSER AND A LATCH

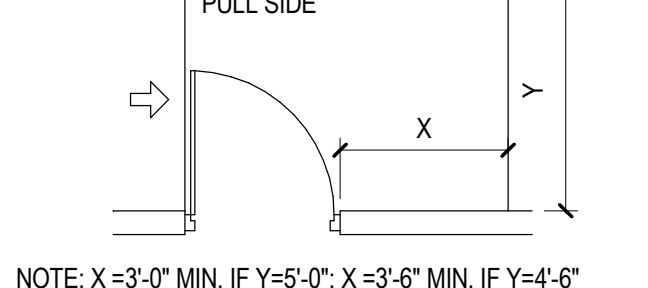

NOTE: X = 3'-0" MIN. IF Y = 5'-0"; X = 3'-6" MIN. IF Y = 4'-6"

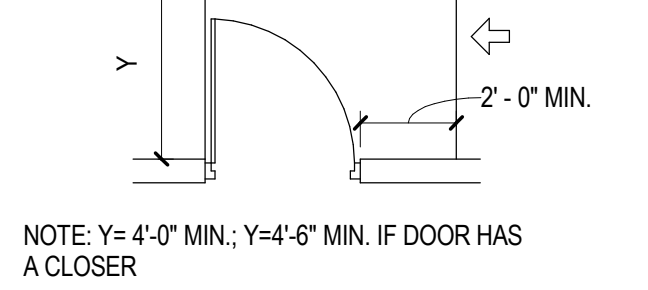

NOTE: Y = 4'-0" MIN.; Y = 4'-6" MIN. IF DOOR HAS A CLOSER

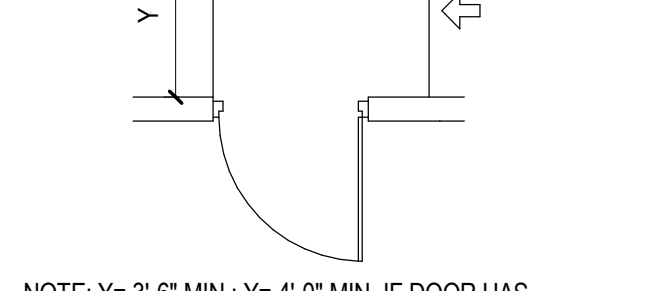

NOTE: Y = 3'-6" MIN.; Y = 4'-0" MIN. IF DOOR HAS A CLOSER

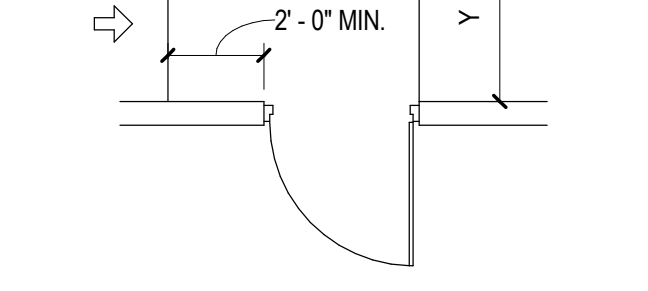

NOTE: Y = 3'-6" MIN.; Y = 4'-0" MIN. IF DOOR HAS A CLOSER

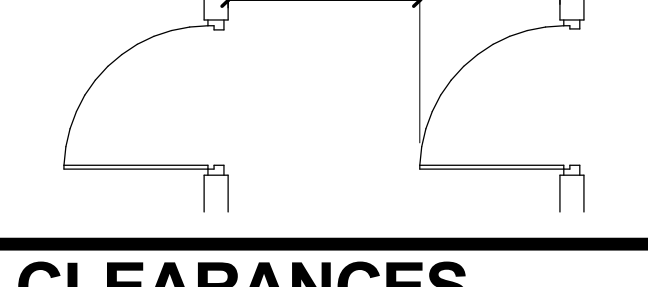
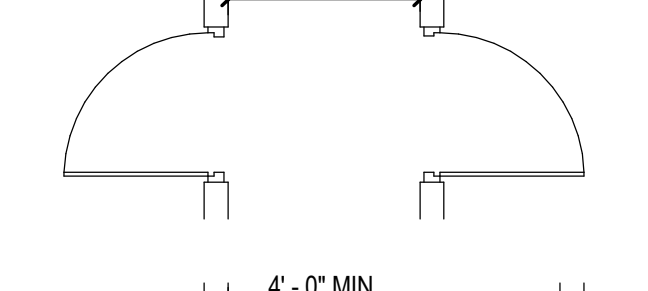

CLEARANCES
SCALE: 1/4" = 1'-0"

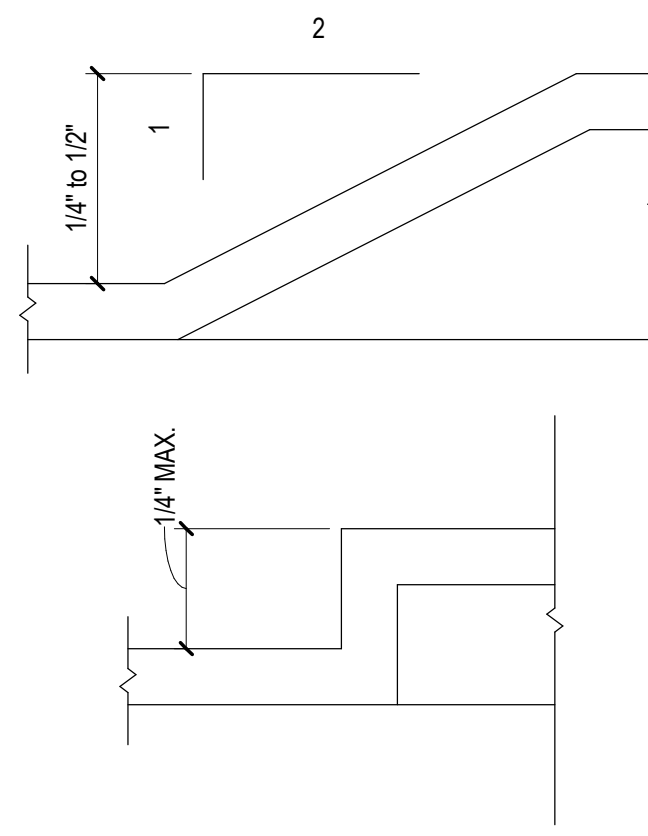

LEVEL CHANGES
SCALE: 1'-0" = 1'-0"

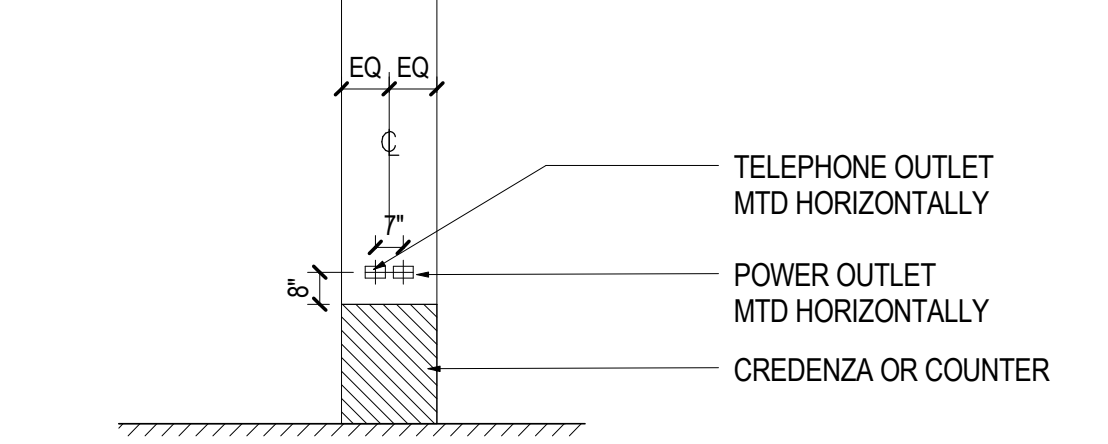

17 LOCATIONS at CRENZAS or COUNTERS OUTLETS

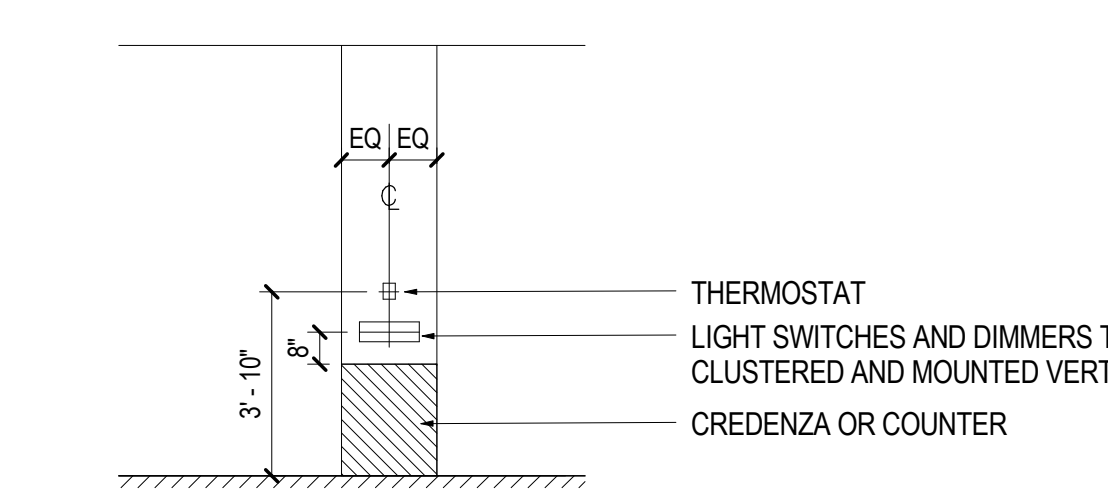

18 LOCATIONS at CRENZAS or COUNTERS SWITCHES and THERMOSTATS

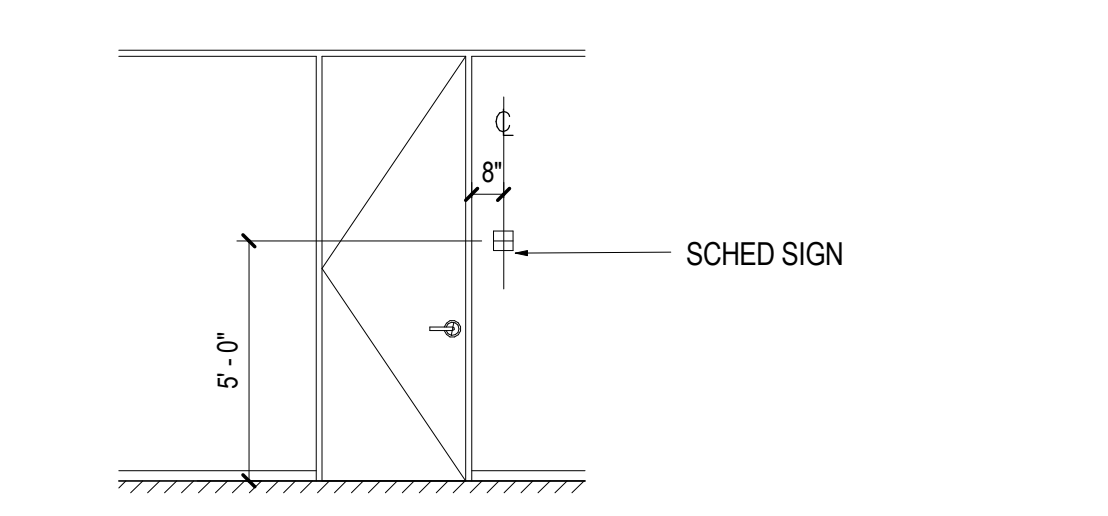

19 LOCATION FOR TYPICAL SIGNS

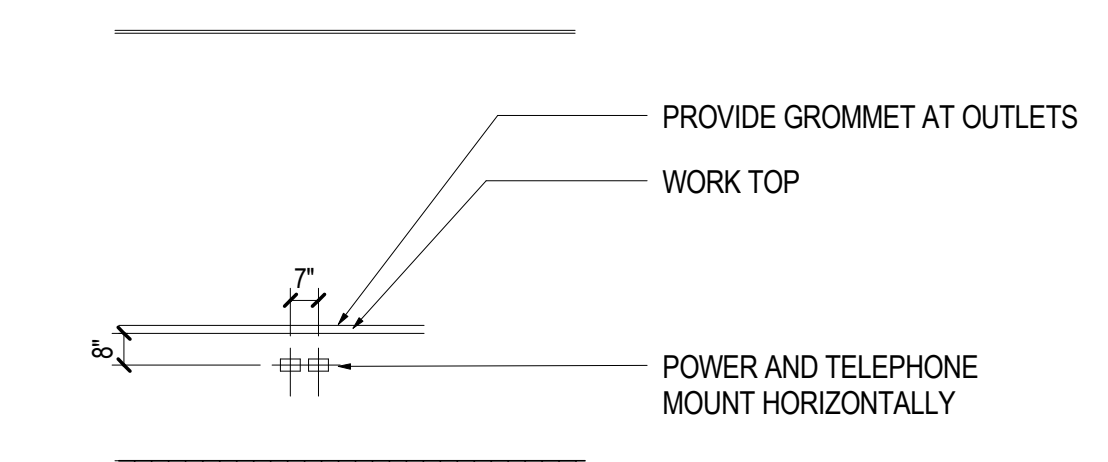

20 LOCATIONS at WORK SURFACES OUTLETS

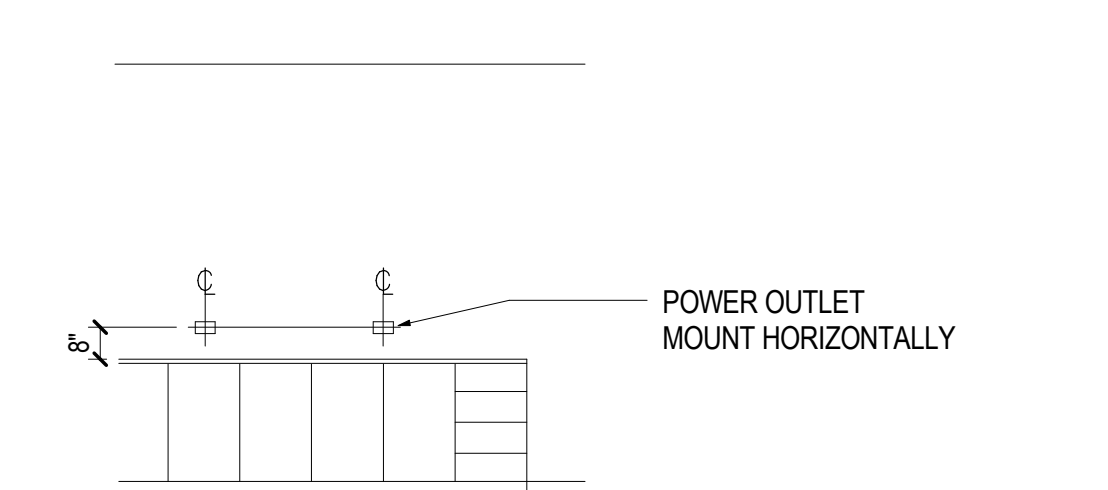

21 LOCATIONS at MILLWORK COUNTERS OUTLETS

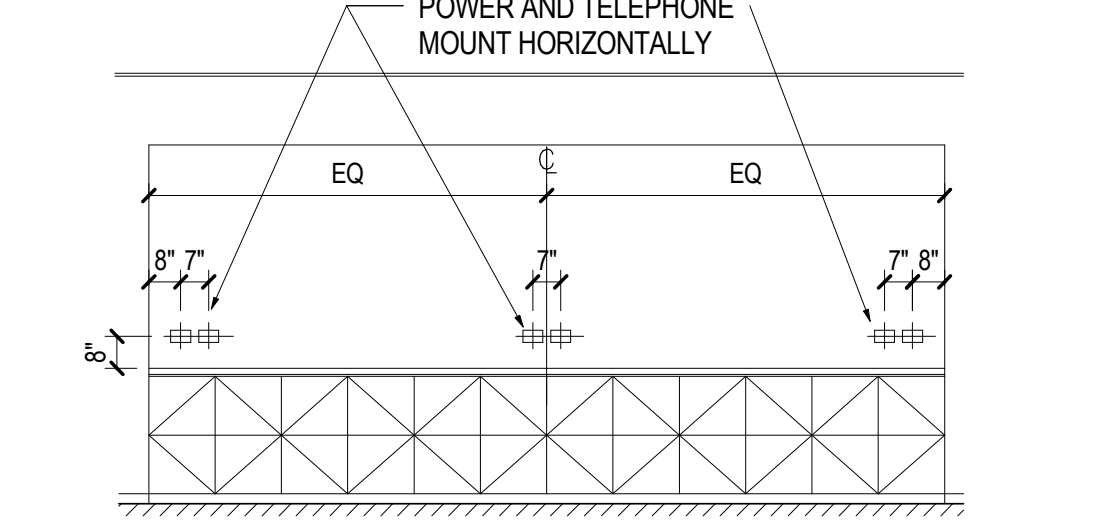

22 LOCATIONS at MILLWORK COUNTERS OUTLETS

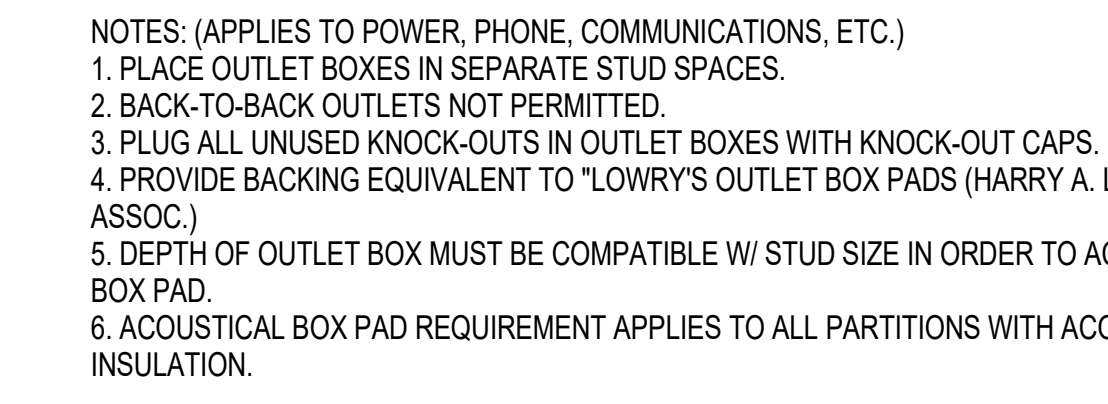
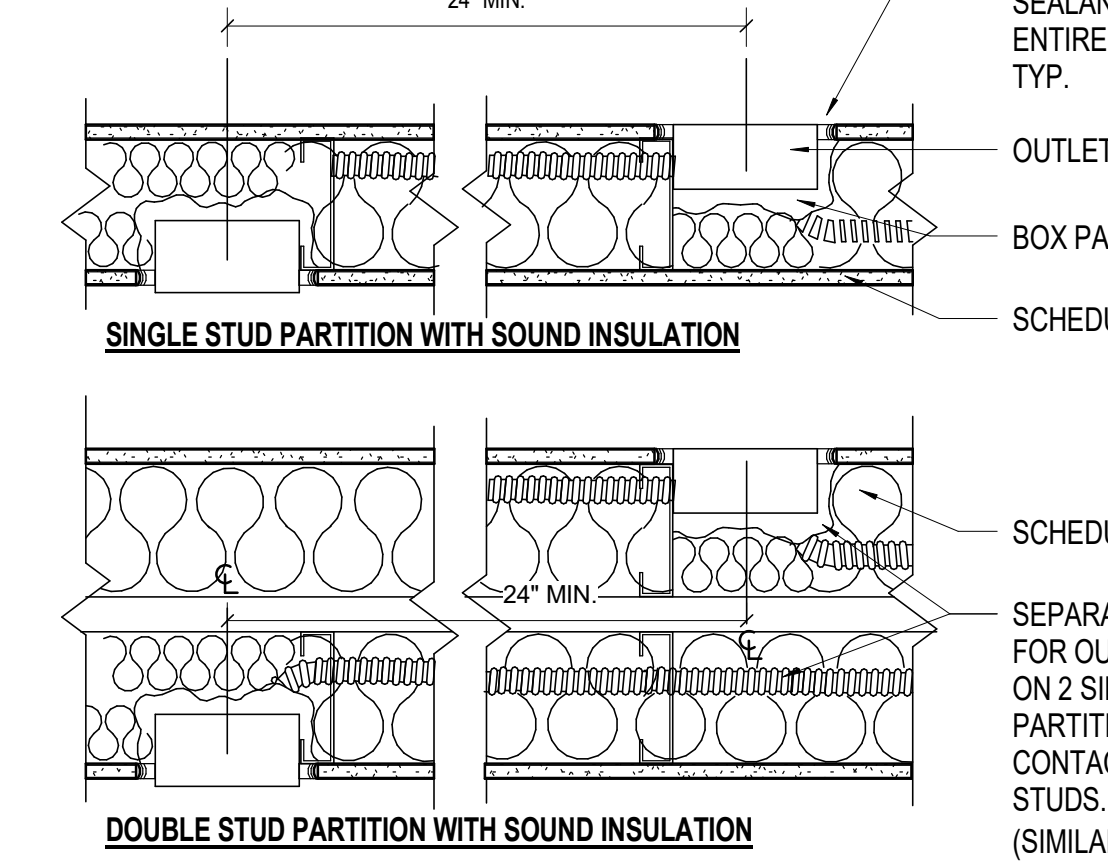

BACK TO BACK OUTLET BOX DETAIL
SCALE: 1 1/2" = 1'-0"

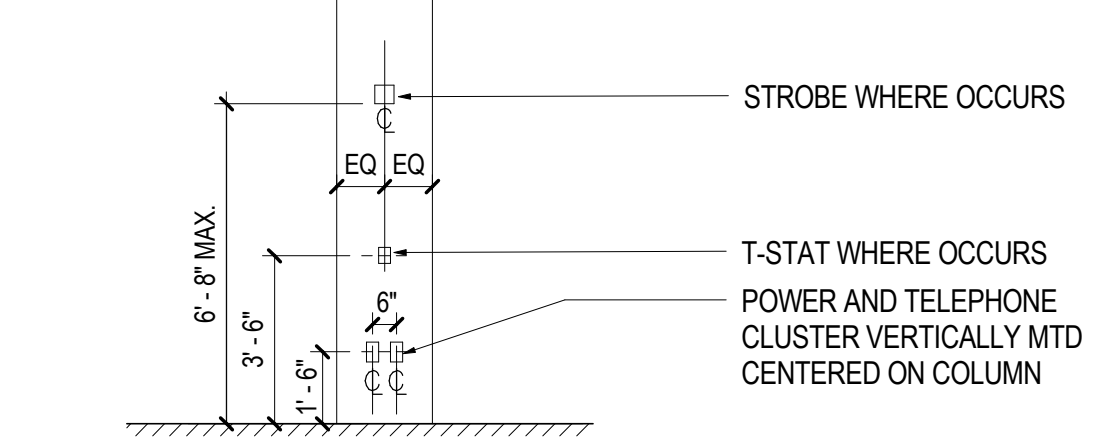

9 LOCATIONS at COLUMNS, BETWEEN DOORS, ETC. OUTLET GROUPS, STROBES and THERMOSTATS

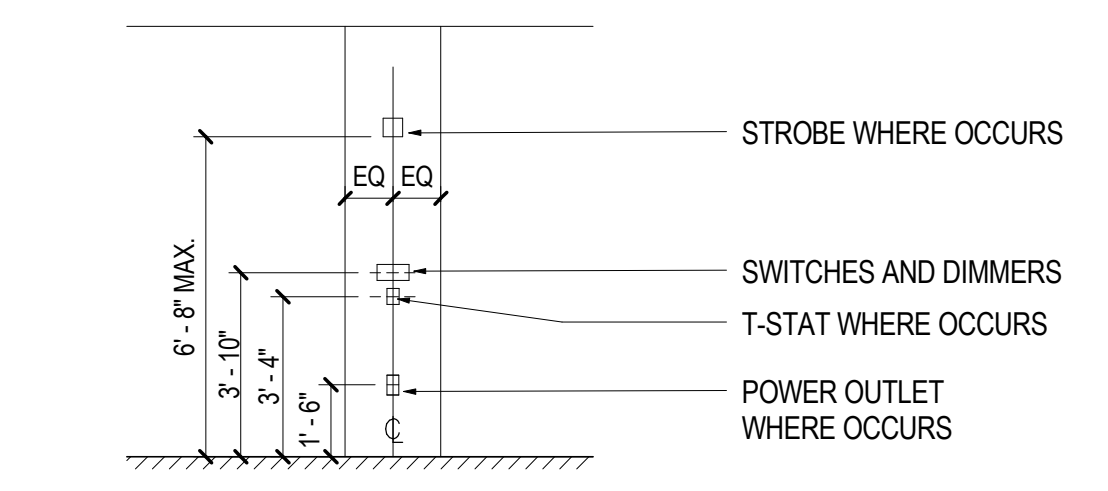

10 LOCATIONS at COLUMNS, BETWEEN DOORS, ETC. SWITCHES, STROBES and THERMOSTATS

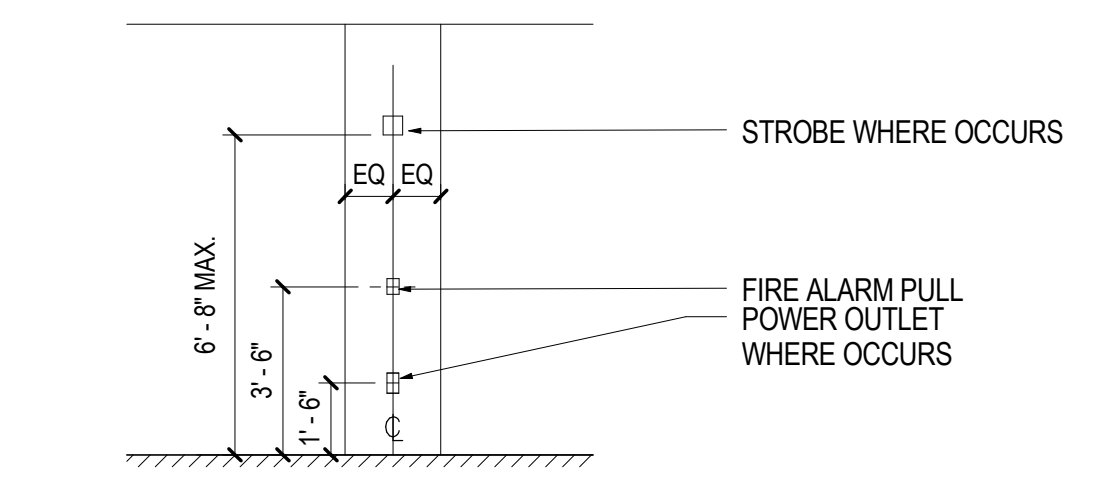

11 LOCATIONS at COLUMNS, BETWEEN DOORS, ETC. OUTLETS, STROBES and FIRE ALARM PULLS

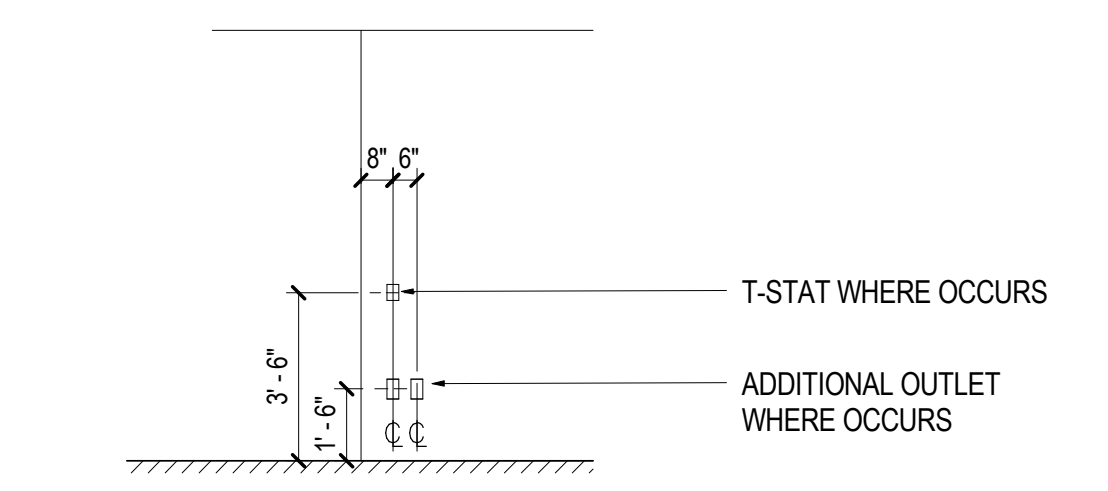

12 LOCATIONS at CORNERS OUTLETS

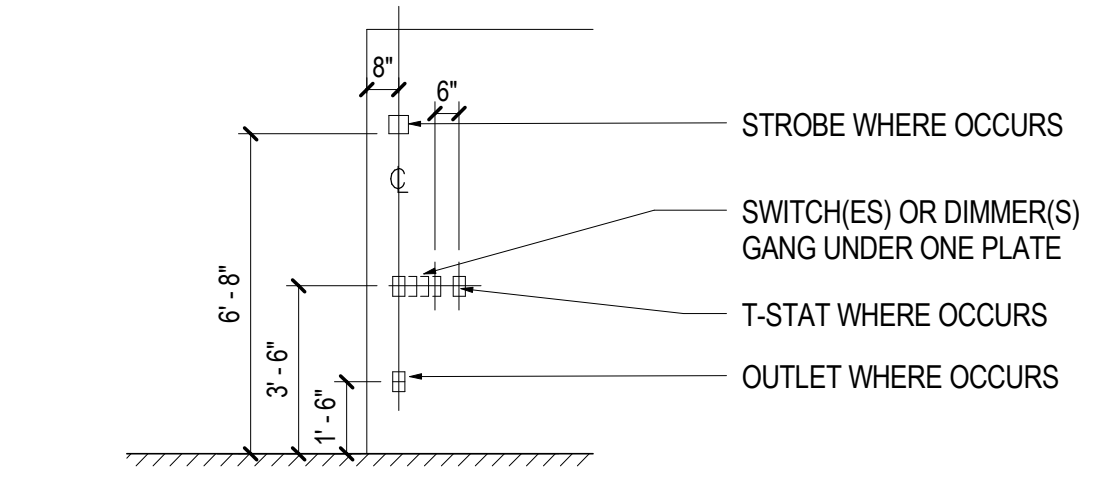

13 LOCATIONS at CORNERS SWITCHES, OUTLETS, STROBES and THERMOSTATS

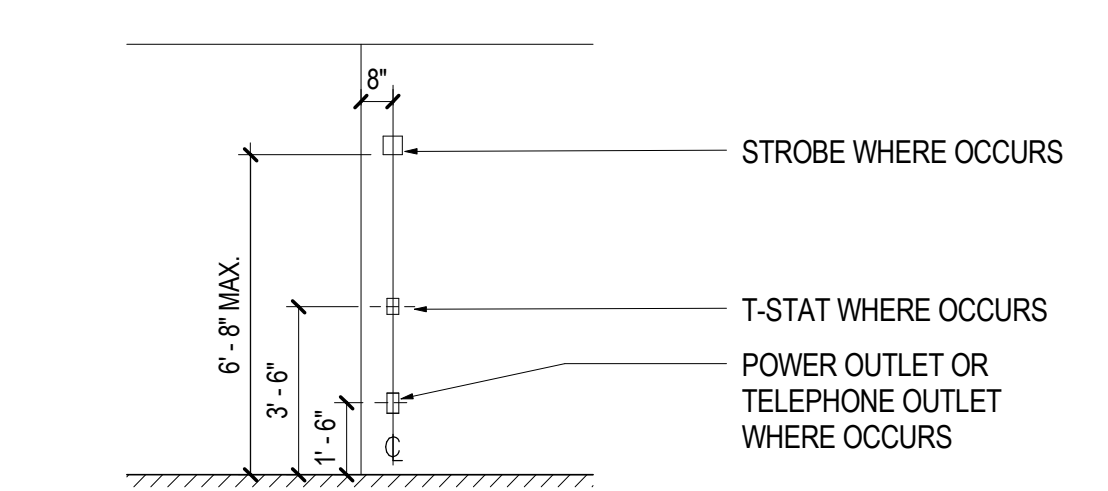

14 LOCATIONS at CORNERS OUTLETS, STROBES and THERMOSTATS

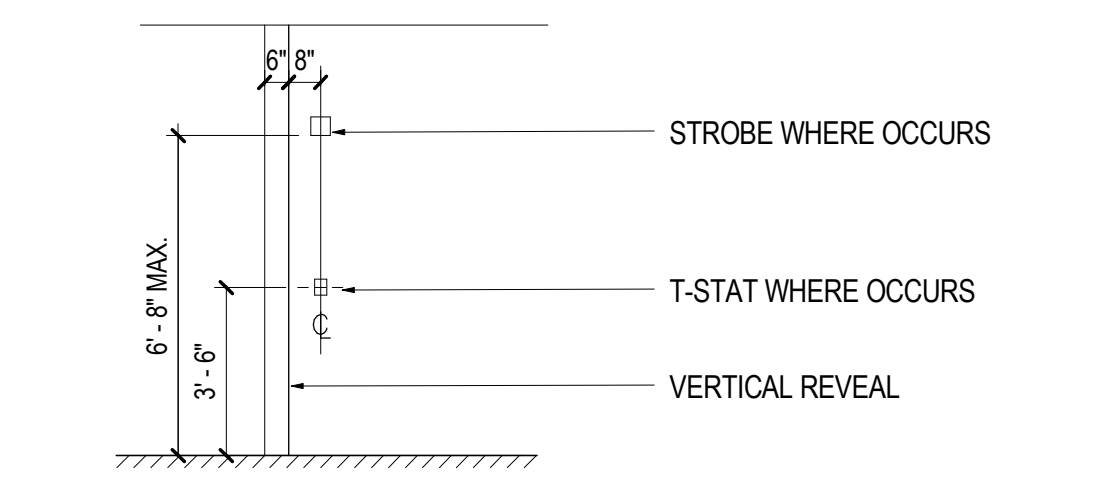

15 LOCATIONS at CORNERS with REVEALS STROBES and THERMOSTATS

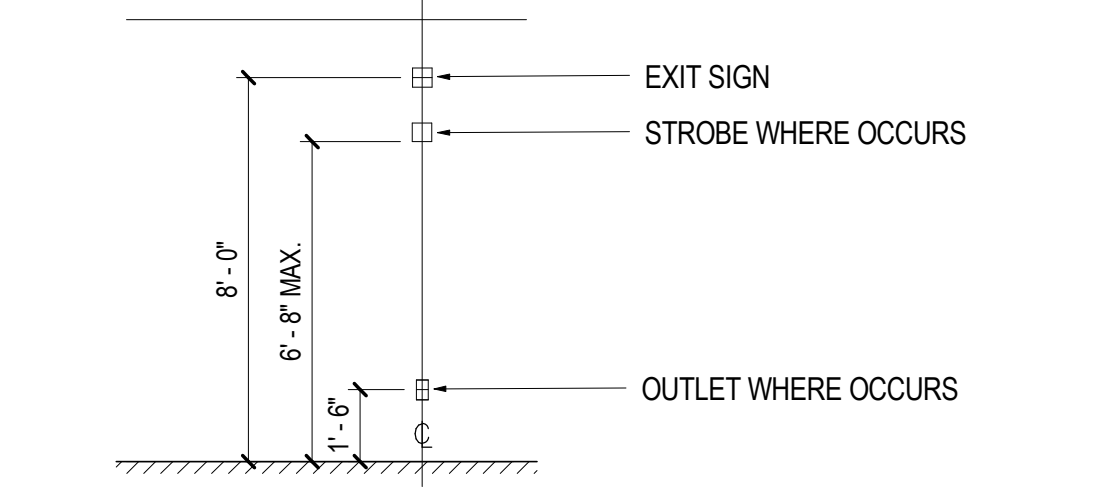

16 LOCATION FOR EXIT SIGNS (WALL MOUNTED)

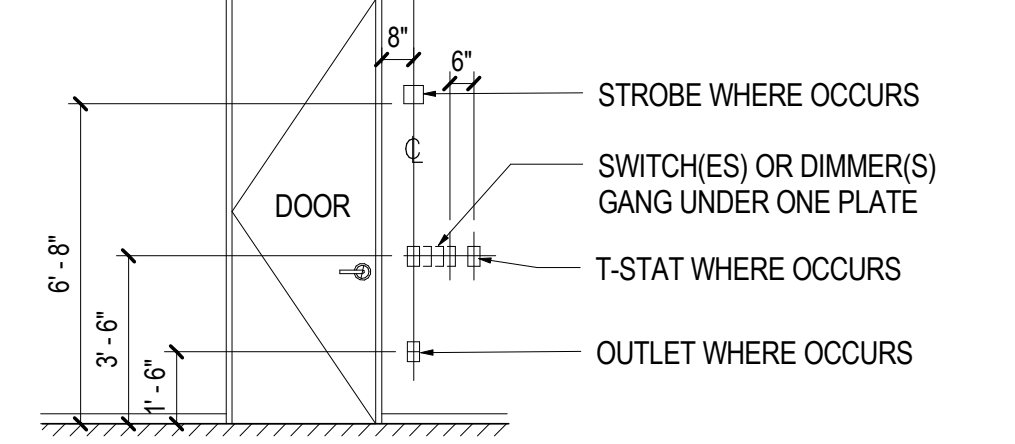

1 LOCATIONS at DOOR JAMBS SWITCH and THERMOSTAT

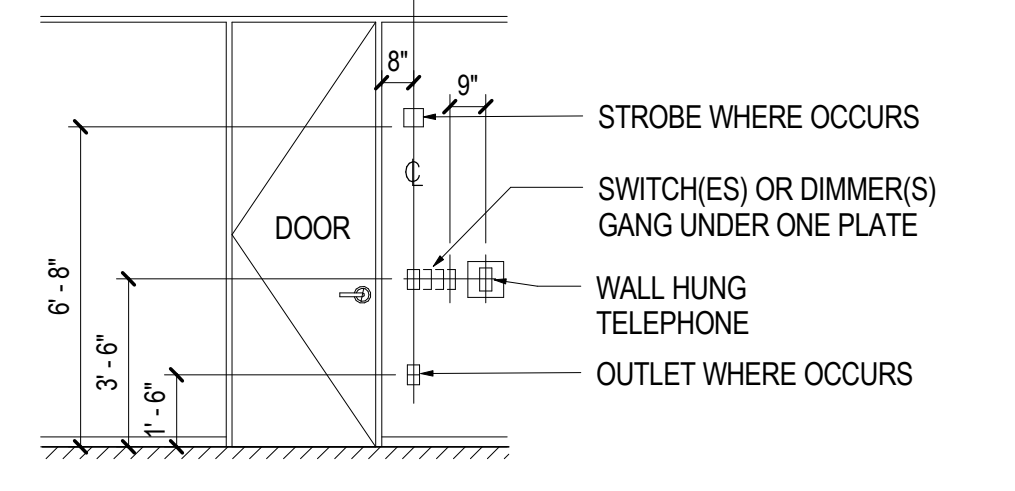

2 LOCATIONS at DOOR JAMBS SWITCH and TELEPHONE

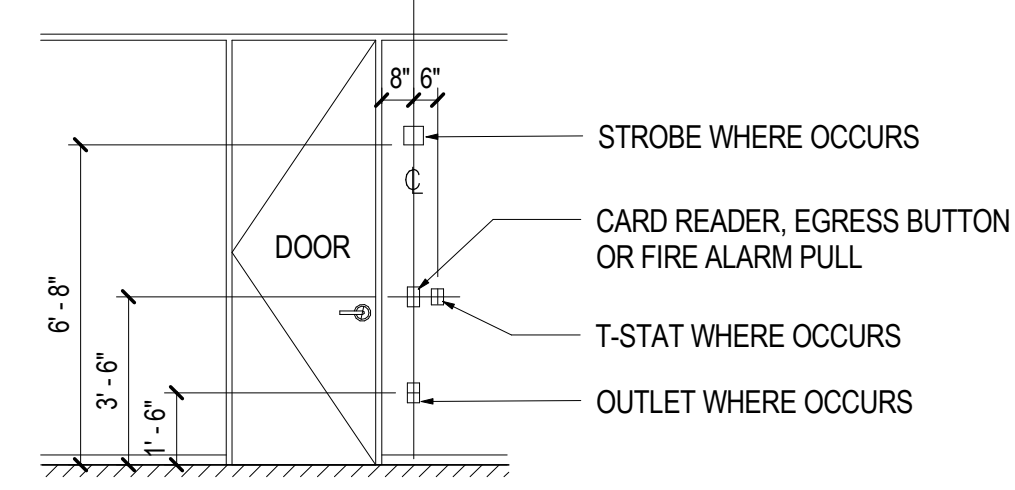

3 LOCATIONS at DOOR JAMBS CARD READER, EGRESS BUTTON or FIRE ALARM PULL

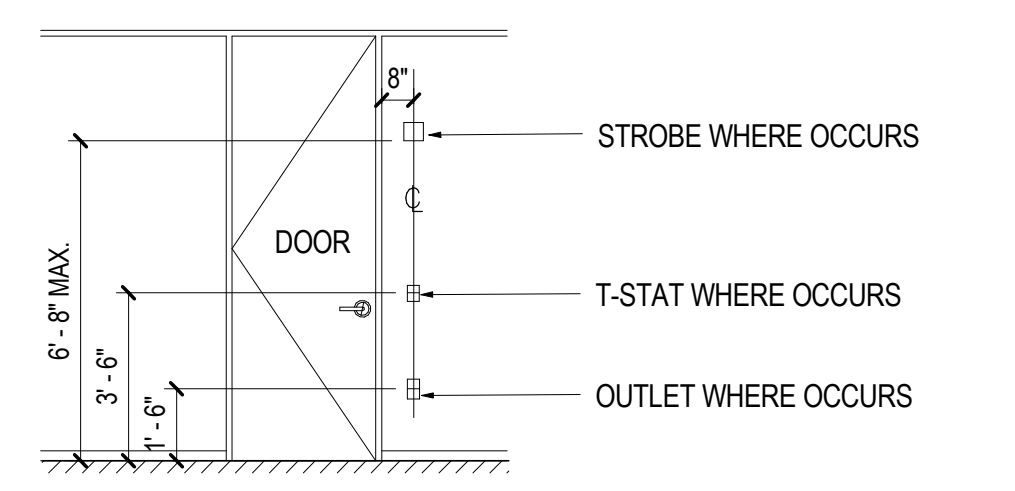

4 LOCATIONS at DOOR JAMBS THERMOSTAT, STROBE or OUTLET

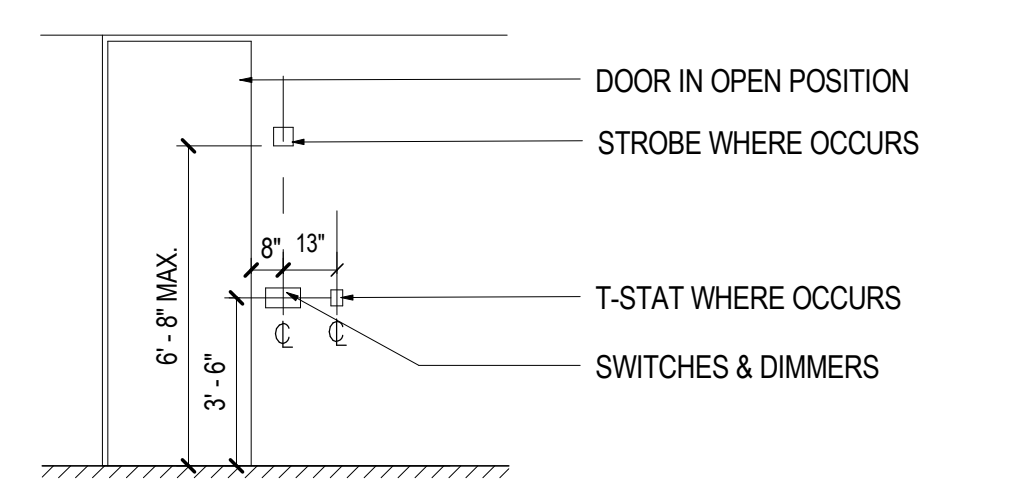

5 LOCATIONS at OPEN DOORS SWITCHES, STROBES and THERMOSTATS

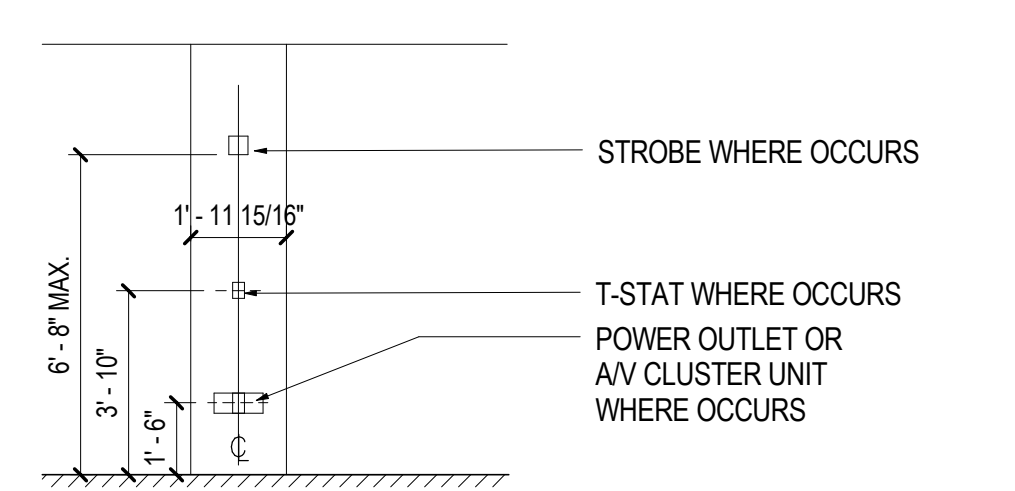

6 LOCATIONS at COLUMNS, BETWEEN DOORS, ETC. OUTLETS, STROBES and THERMOSTATS

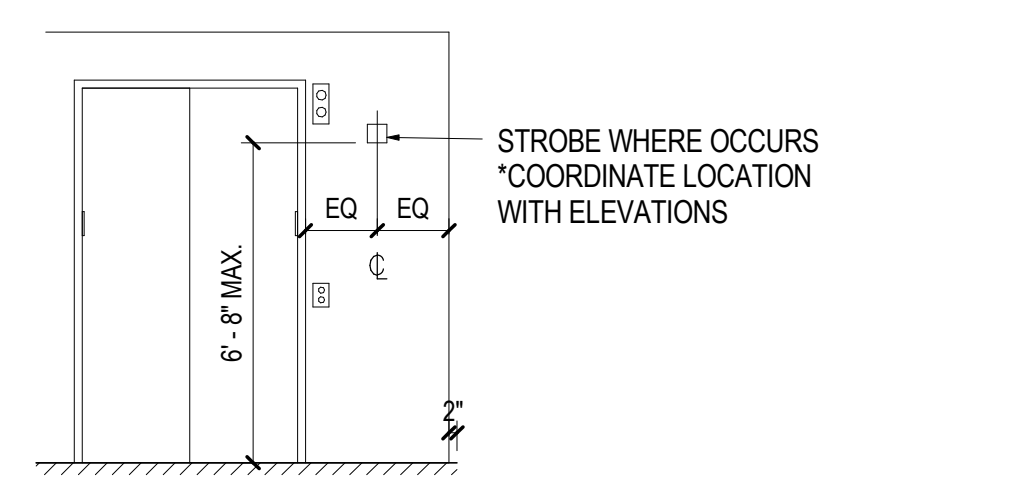

7 LOCATIONS at FREIGHT ELEVATORS STROBES

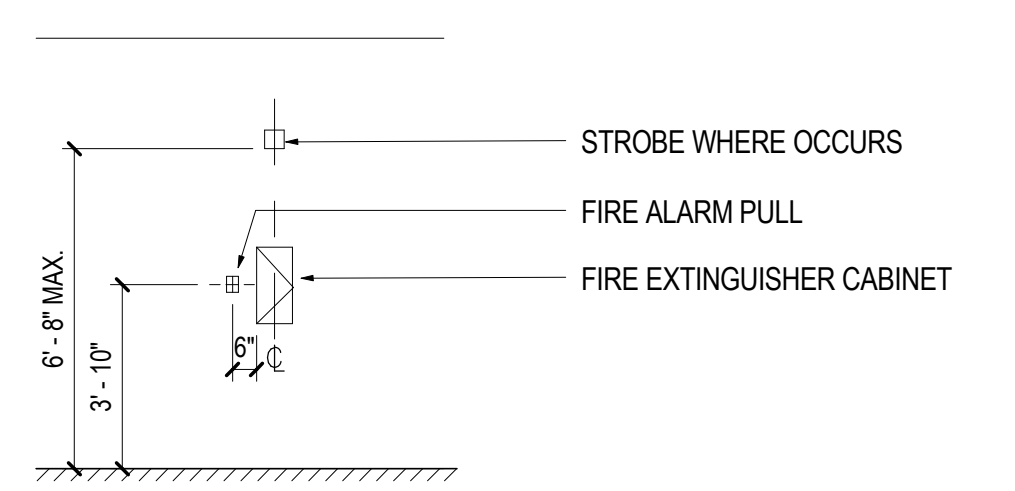

8 LOCATIONS at FIRE EXTINGUISHER CABINET STROBES and FIRE ALARM PULLS



2211 Congress Street
Portland, ME 04122

Gensler

214 North Tryon Street
Suite 2320
Charlotte, NC 28202
United States

Tel 704.377.2725
Fax 704.377.2807

Date 12/15/17 Description ISSUE FOR PERMIT & CONSTRUCTION

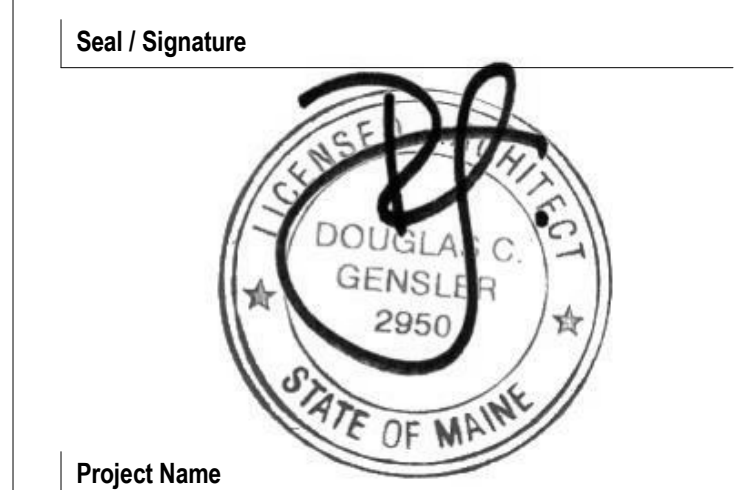

Project Name Unum Workplace Transformation - Phase 2 & 3 (HO2 & HO3)

Project Number 59.6481.003

Description ADA INFORMATION & TYPICAL MOUNTING HEIGHTS

Scale As indicated

G00.003