

DUAL 65" FLAT PANEL WITH SPARK SYSTEM ABOVE
 WEIGHT (LBS) 245
 01

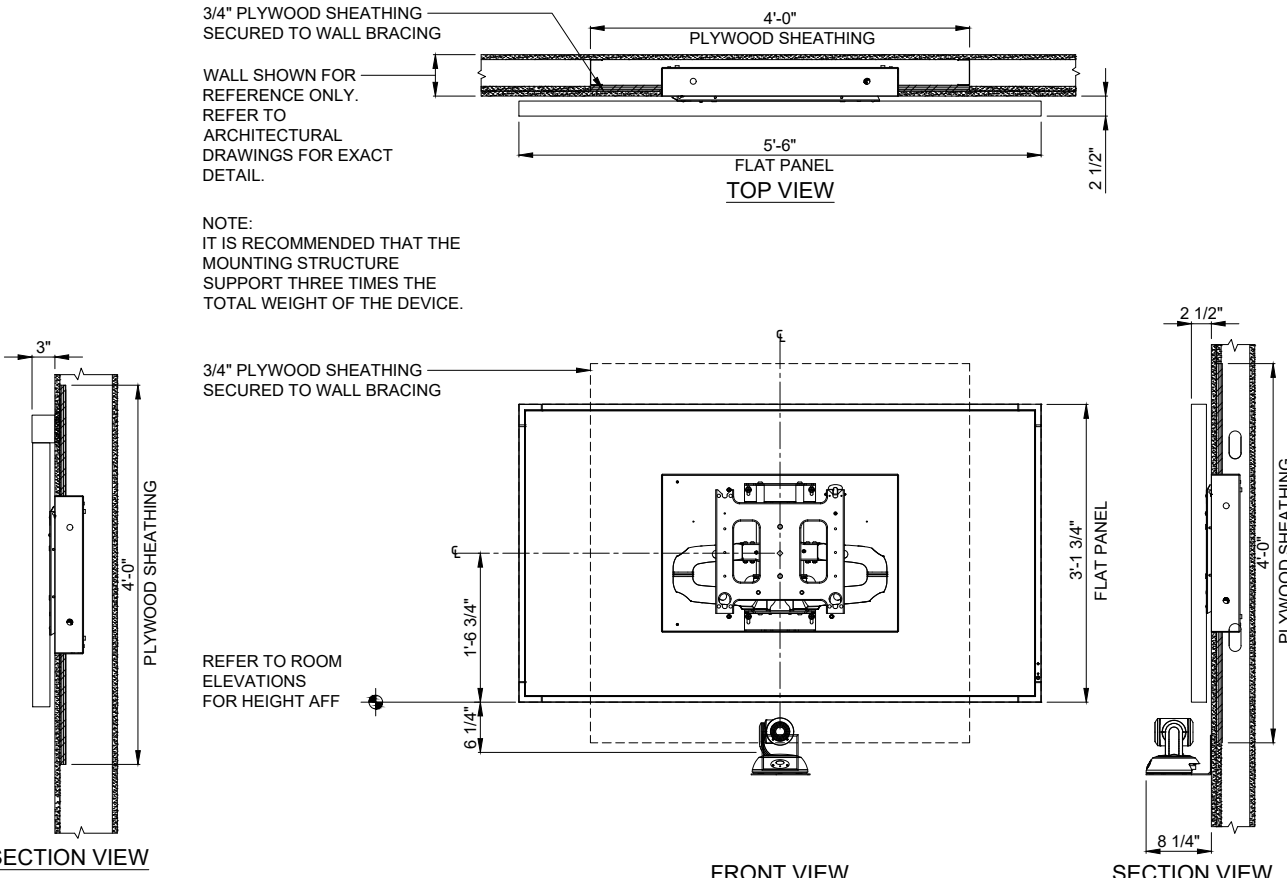

75" FLAT PANEL DISPLAYS WITH CAMERA BELOW
 WEIGHT (LBS) 85
 02

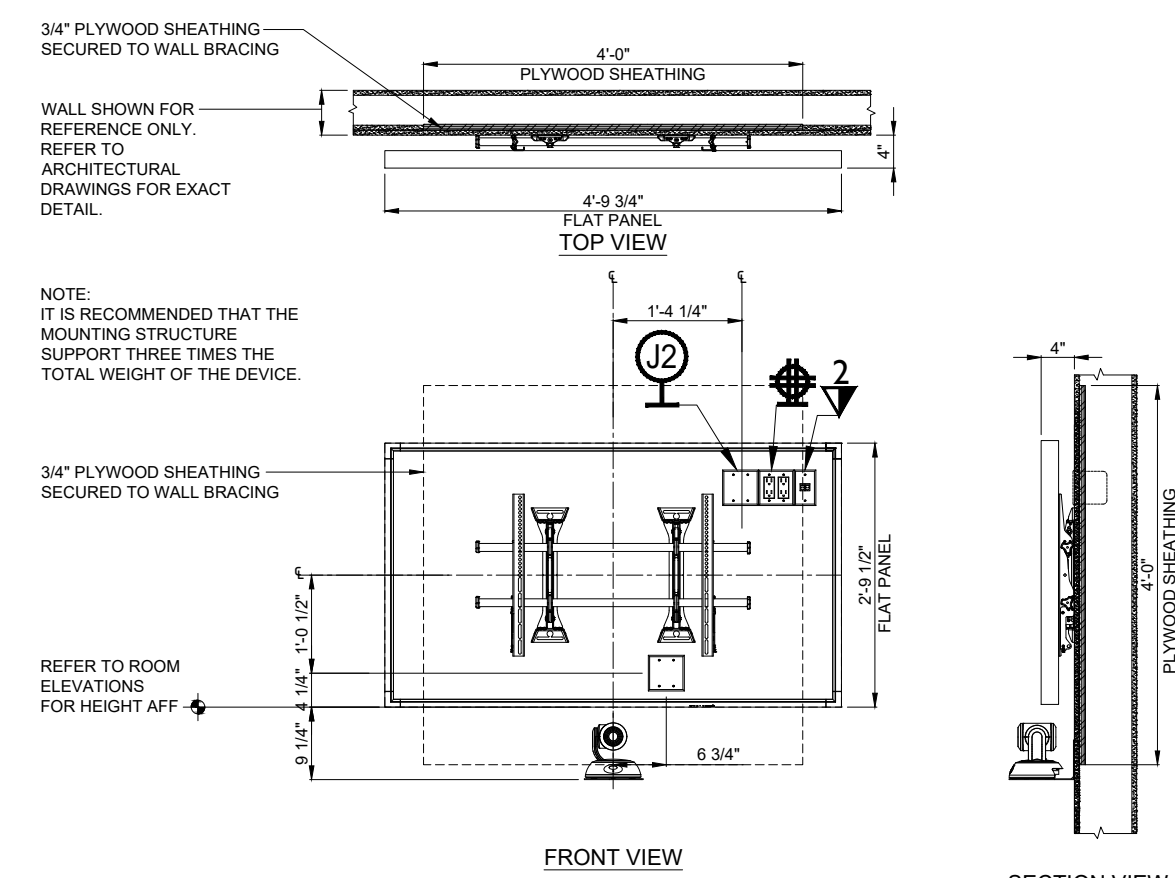

65" FLAT PANEL WITH CAMERA BELOW
 WEIGHT (LBS) 105
 03

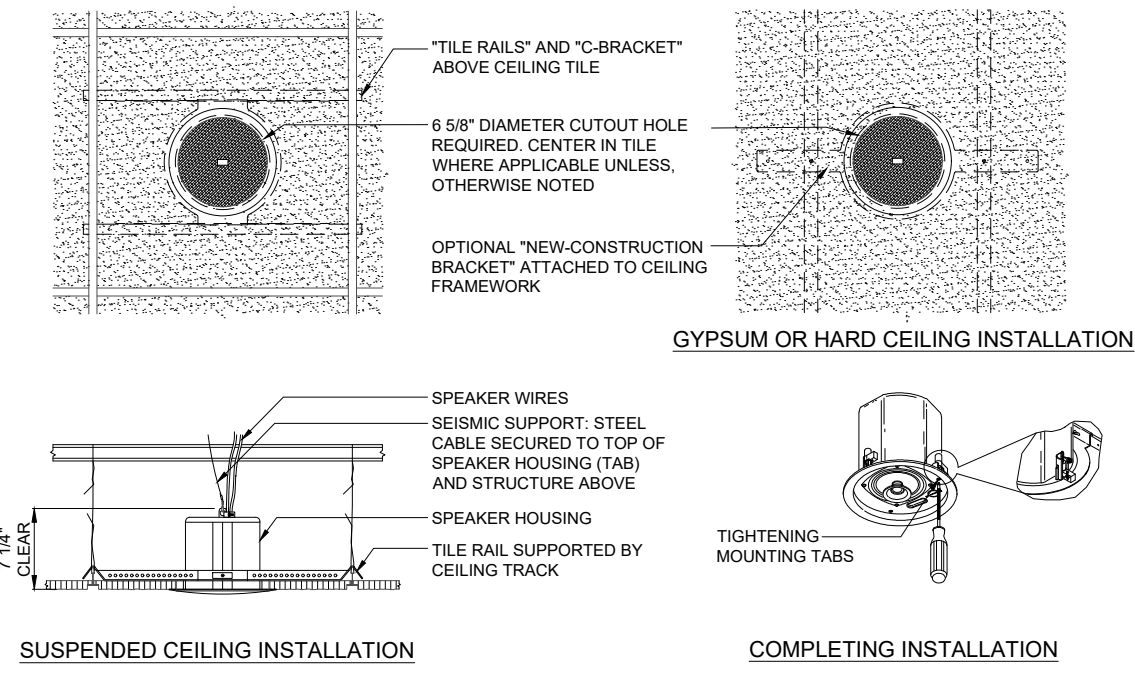

JBL CONTROL 24CT - CEILING SPEAKER
 WEIGHT (LBS) 5
 04

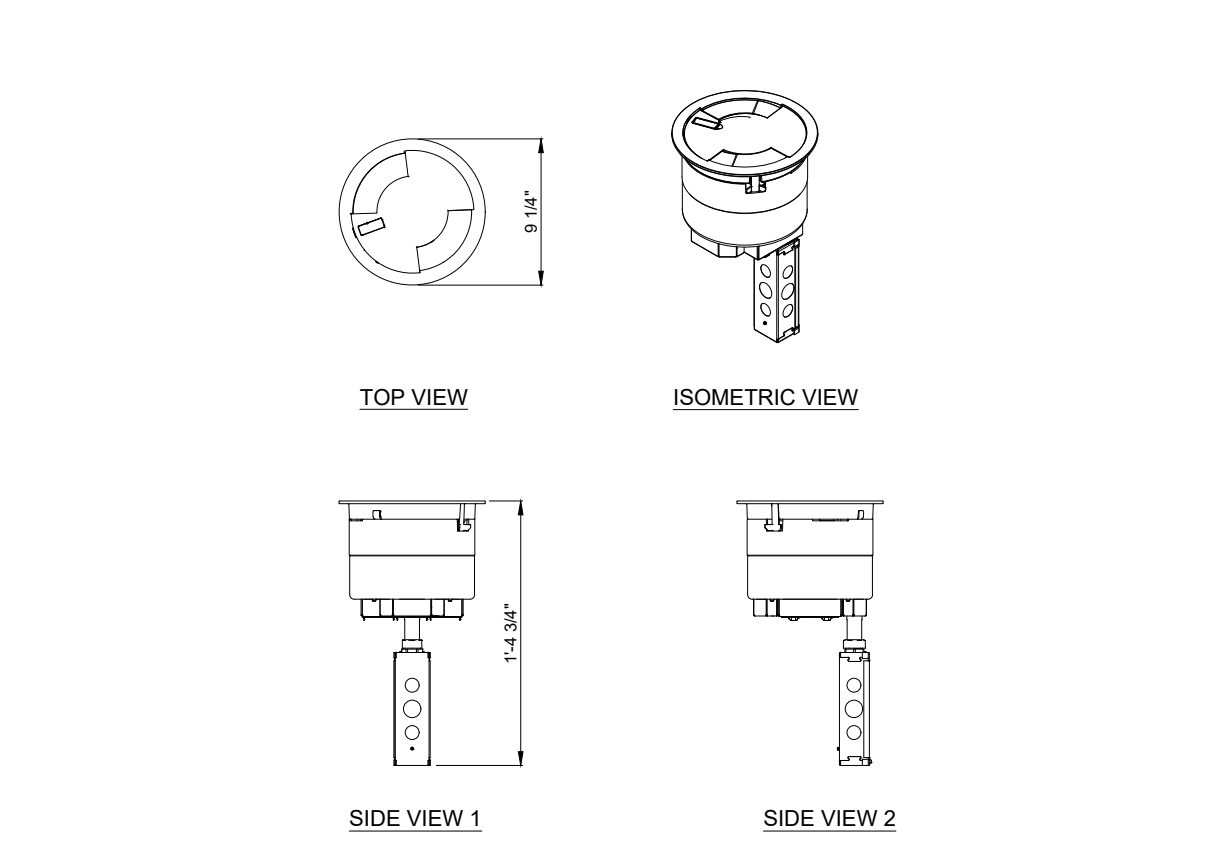

FLOOR POKE THRU
 WEIGHT (LBS) 20
 05

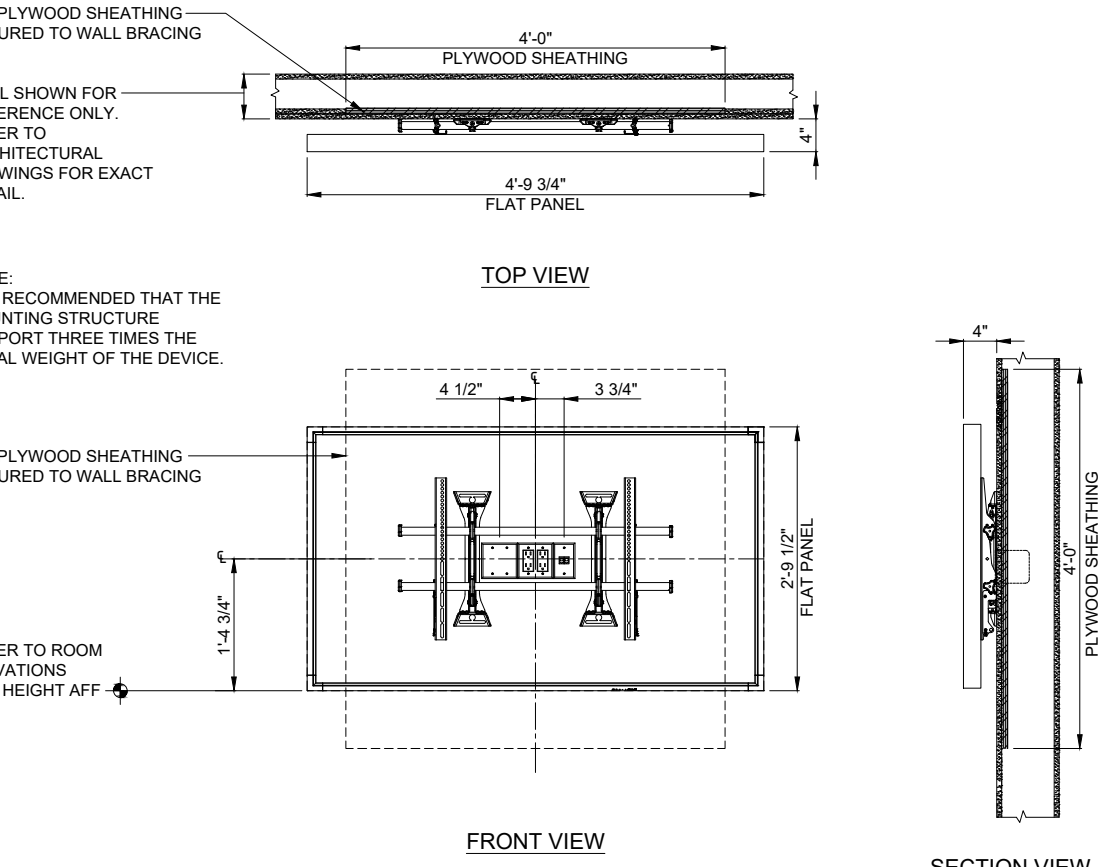

65" FLAT PANEL
 WEIGHT (LBS) 80
 06

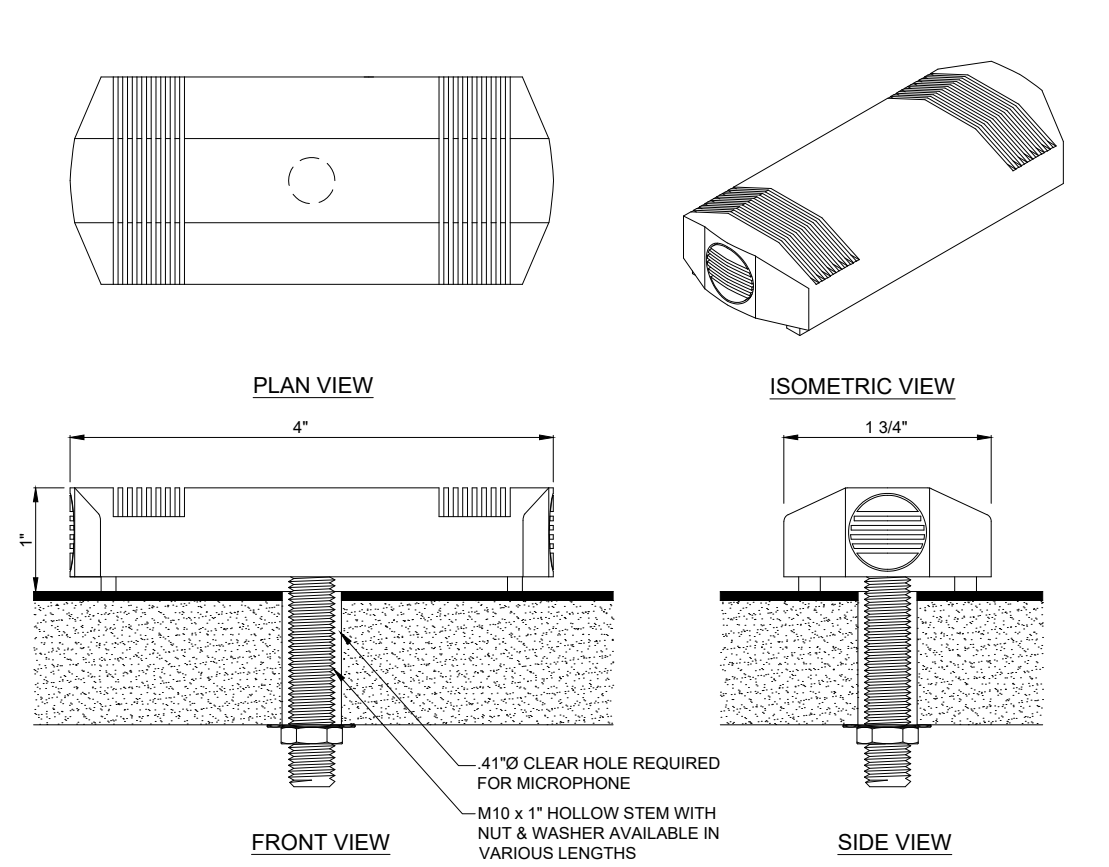

TABLE MICROPHONE
 WEIGHT (LBS) 1.0
 10

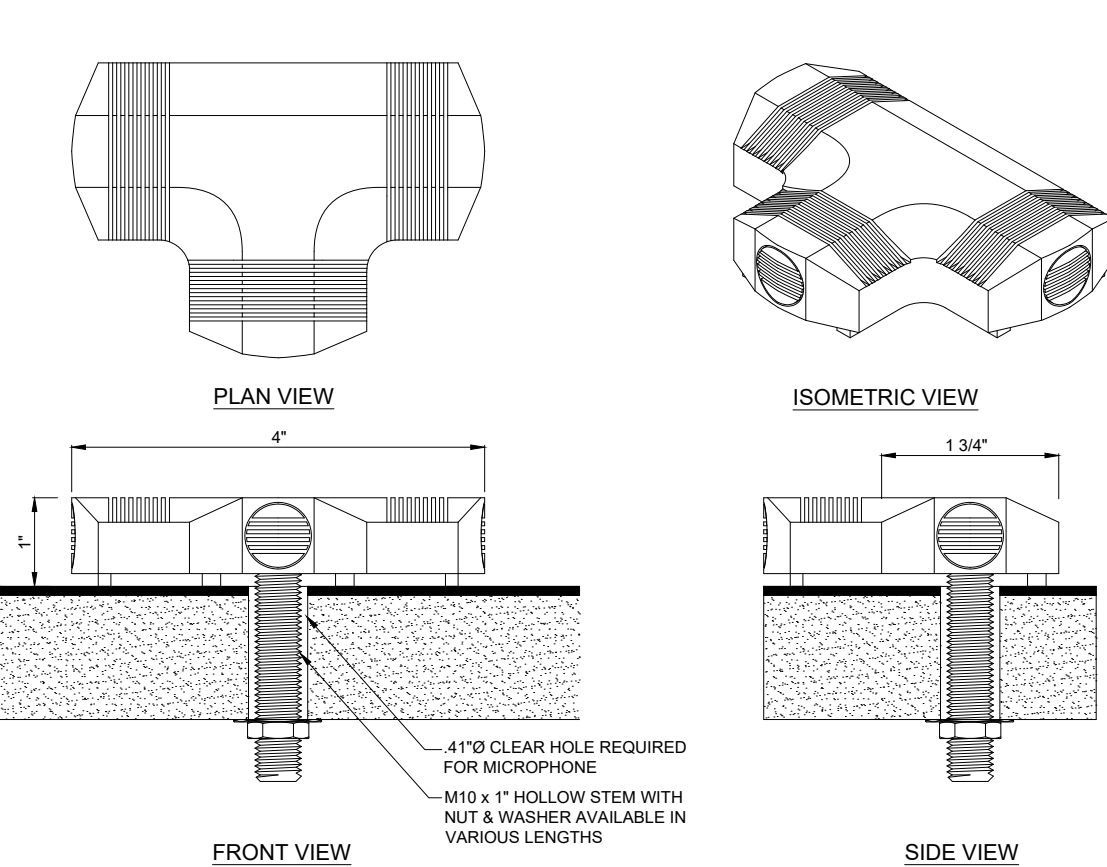

TABLE MICROPHONE
 WEIGHT (LBS) 2.0
 11

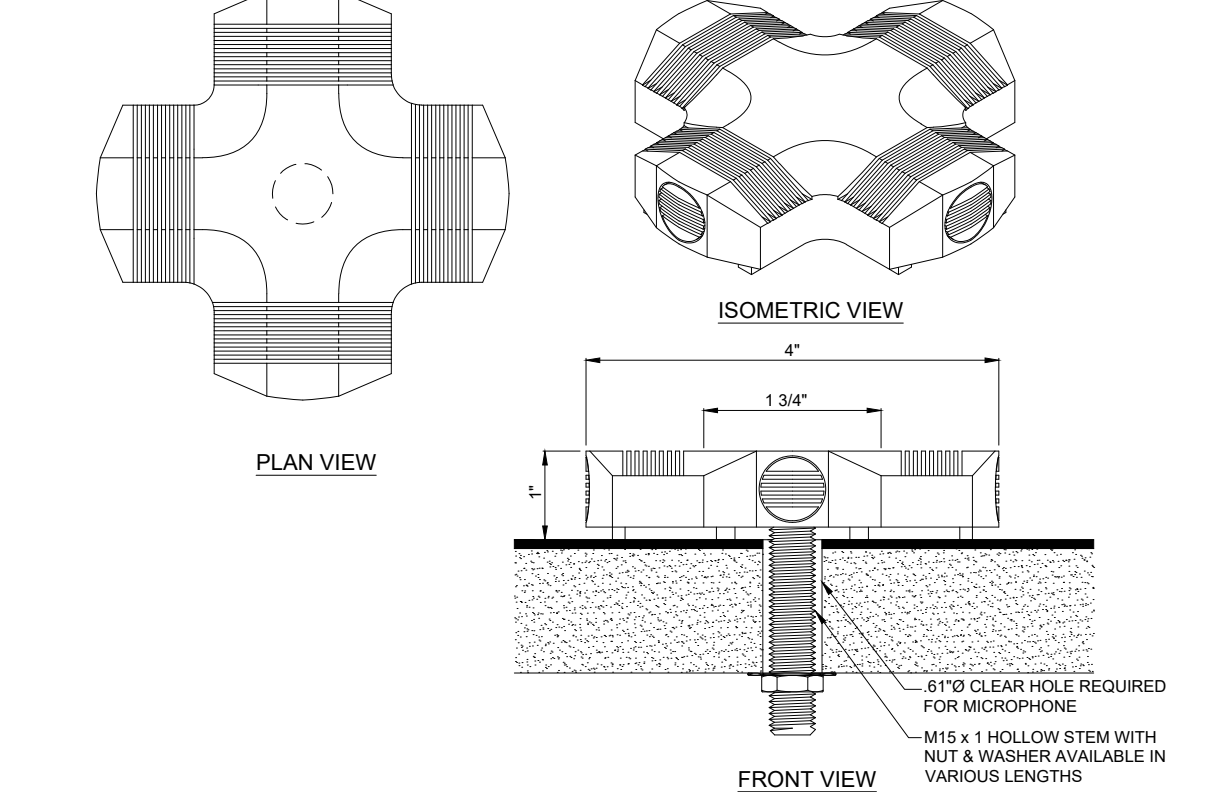
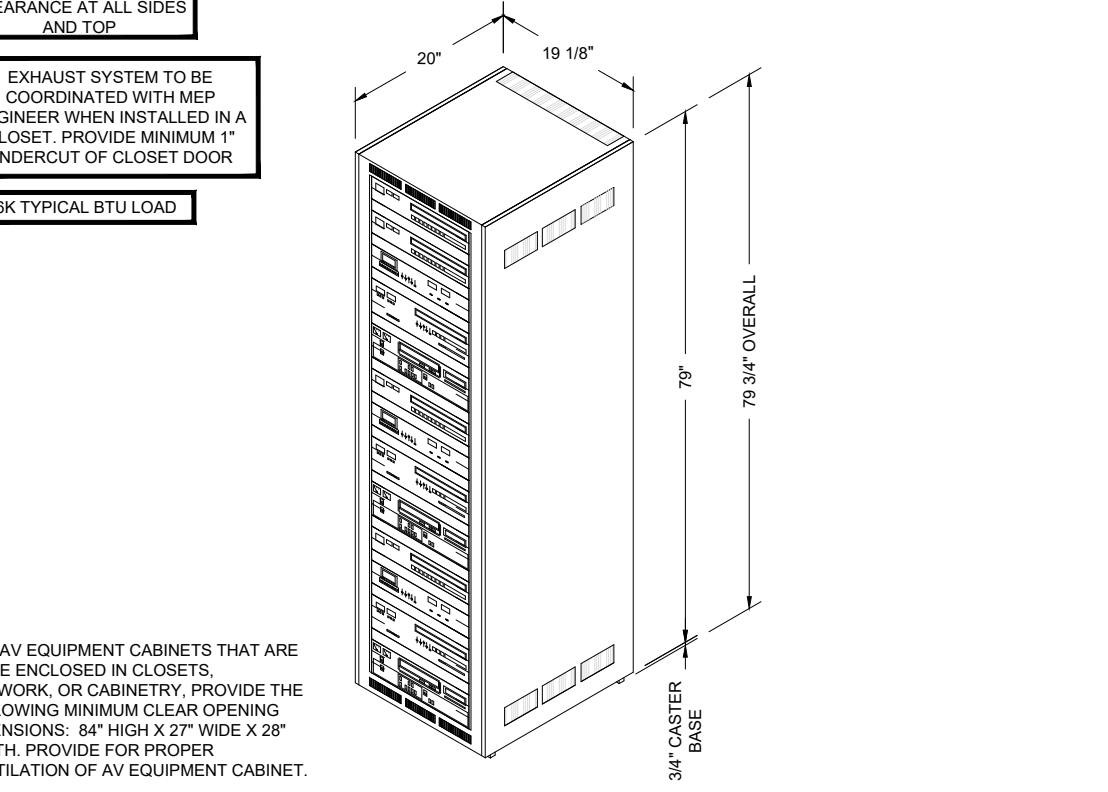
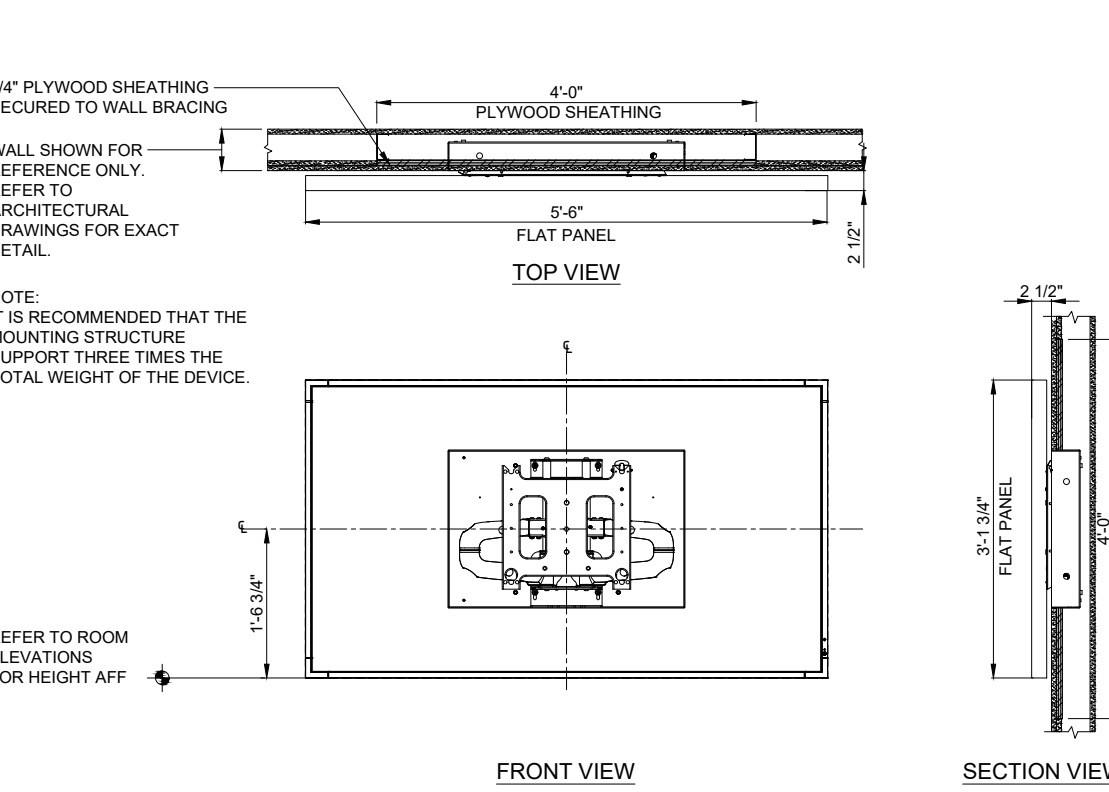

TABLE MICROPHONE
 WEIGHT (LBS) 2.0
 12



AV EQUIPMENT CABINET WITH CASTERS
 WEIGHT (LBS) 400
 13



75" FLAT PANEL DISPLAY
 WEIGHT (LBS) 128
 14

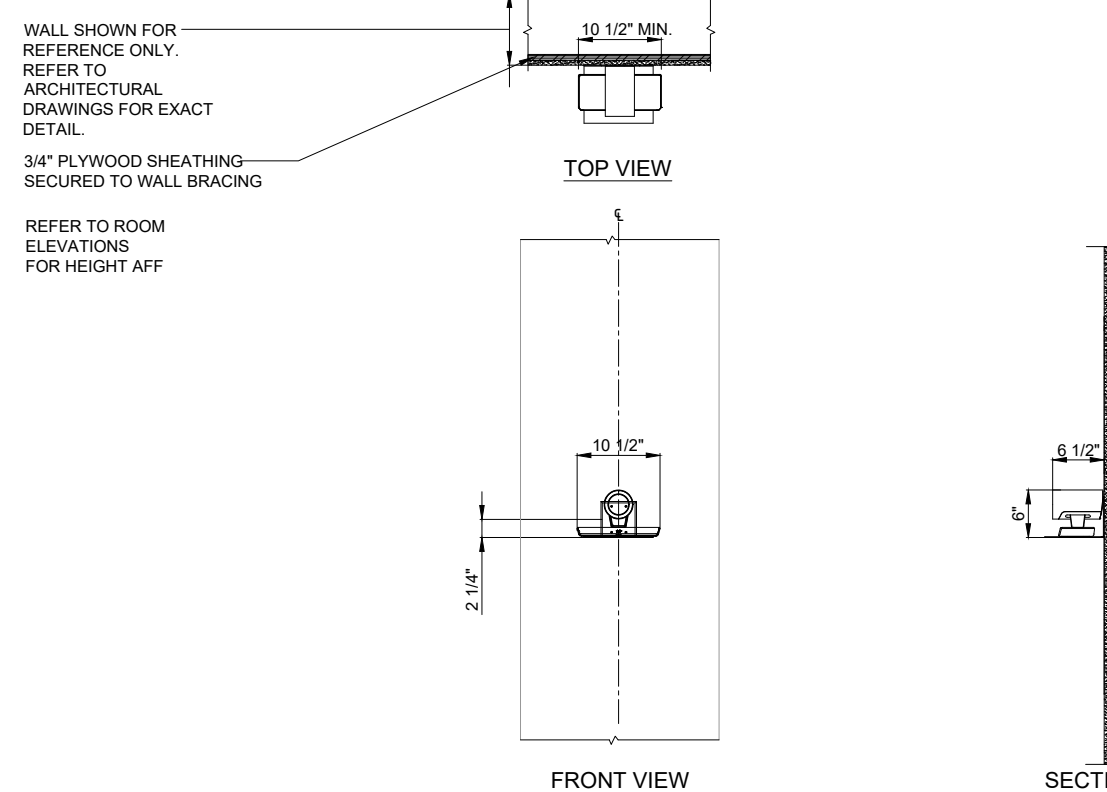

WALL MOUNTED CAMERA
 WEIGHT (LBS) 55
 15

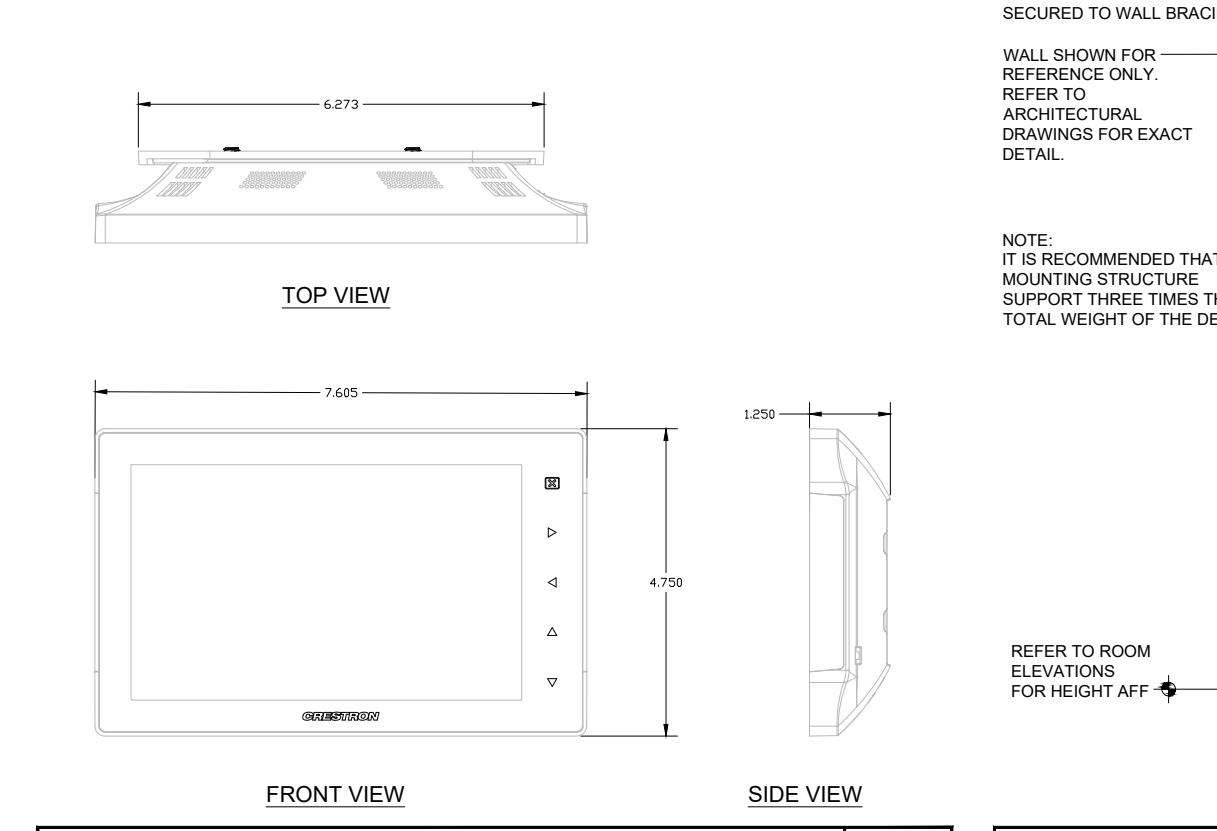

ROOM SCHEDULING TOUCH SCREEN- IN WALL
 WEIGHT (LBS) 1
 16

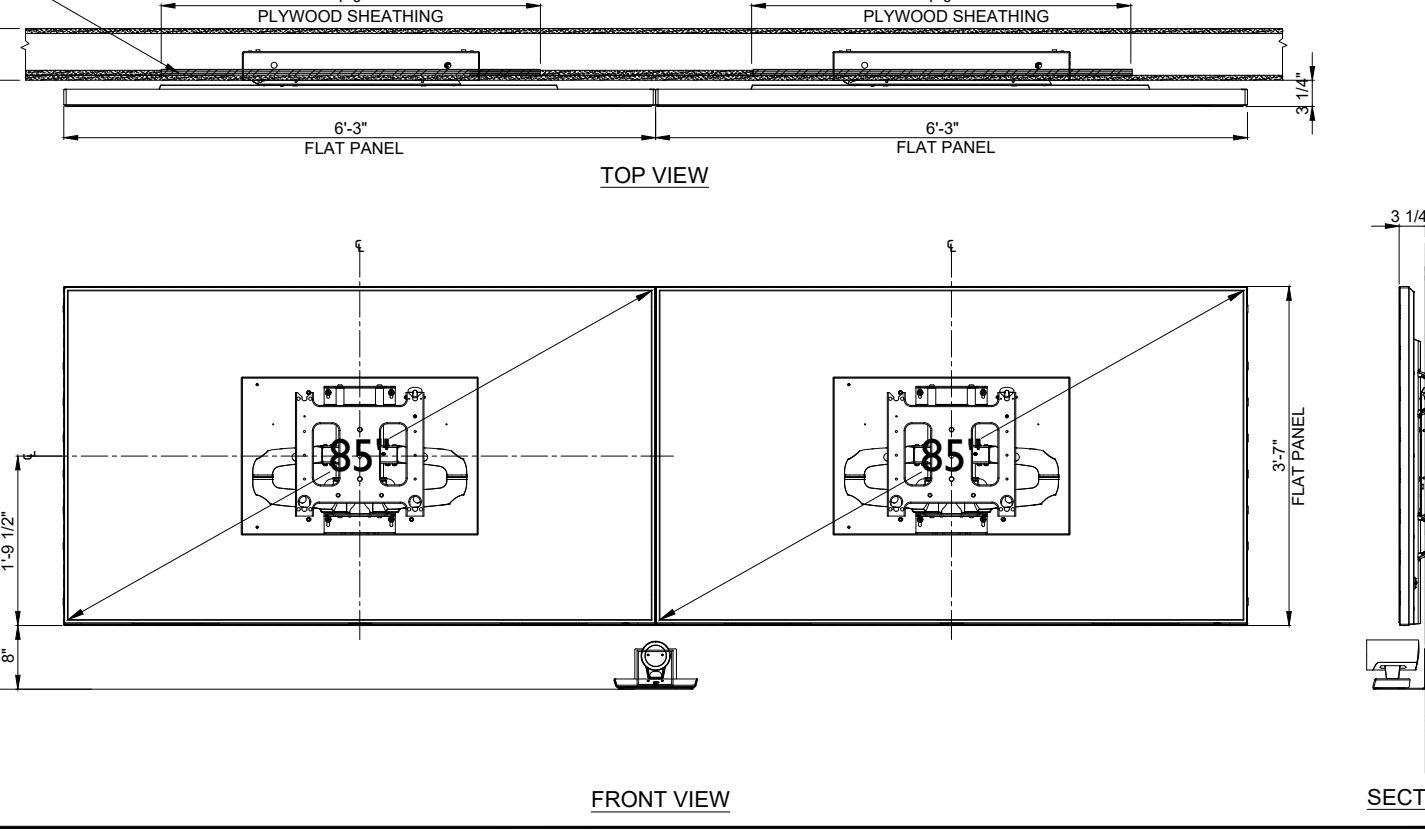

DUAL 85" DISPLAY W/ CAMERA BELOW
 WEIGHT (LBS) 300
 17

Date	Description
11/21/2017	REVIEW & COORDINATION
11/28/2017	REVIEW & COORDINATION
12/05/2017	REVIEW & COORDINATION
12/14/2017	CD

Seal / Signature

NOT FOR CONSTRUCTION

Project Name
 Unum Workplace
 Transformation- Phase 2 & 3
 Project Number
 59.6481.003
 Description

AUDIOVISUAL DETAIL DIAGRAM
 Scale
 1/8" = 1'-0"

AV.601.00