

11 SINK EDGE @ SOLID SURFACE
SCALE: 6" = 1'-0"

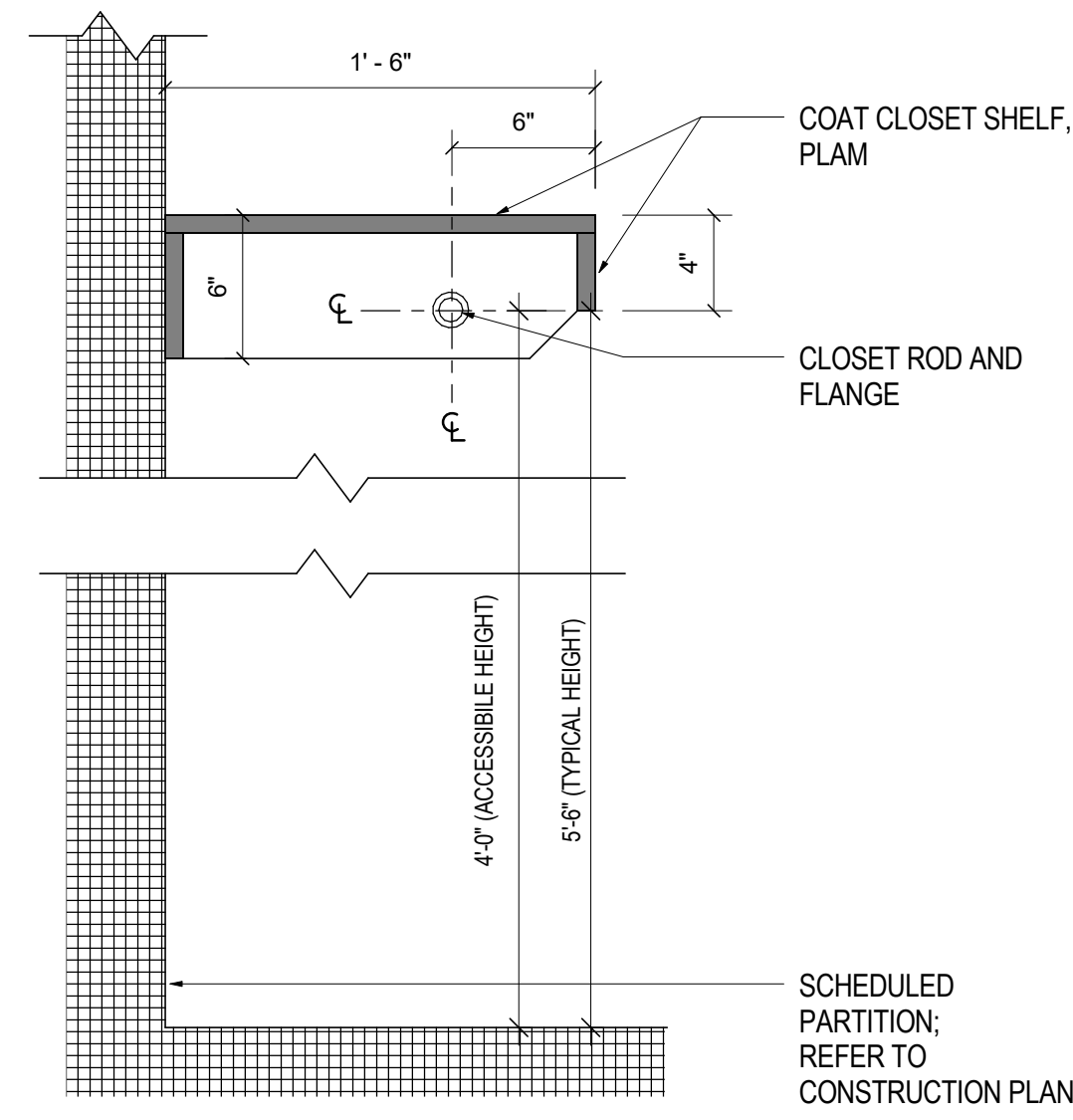

12 CLOSET SHELF AND ROD
SCALE: 1 1/2" = 1'-0"

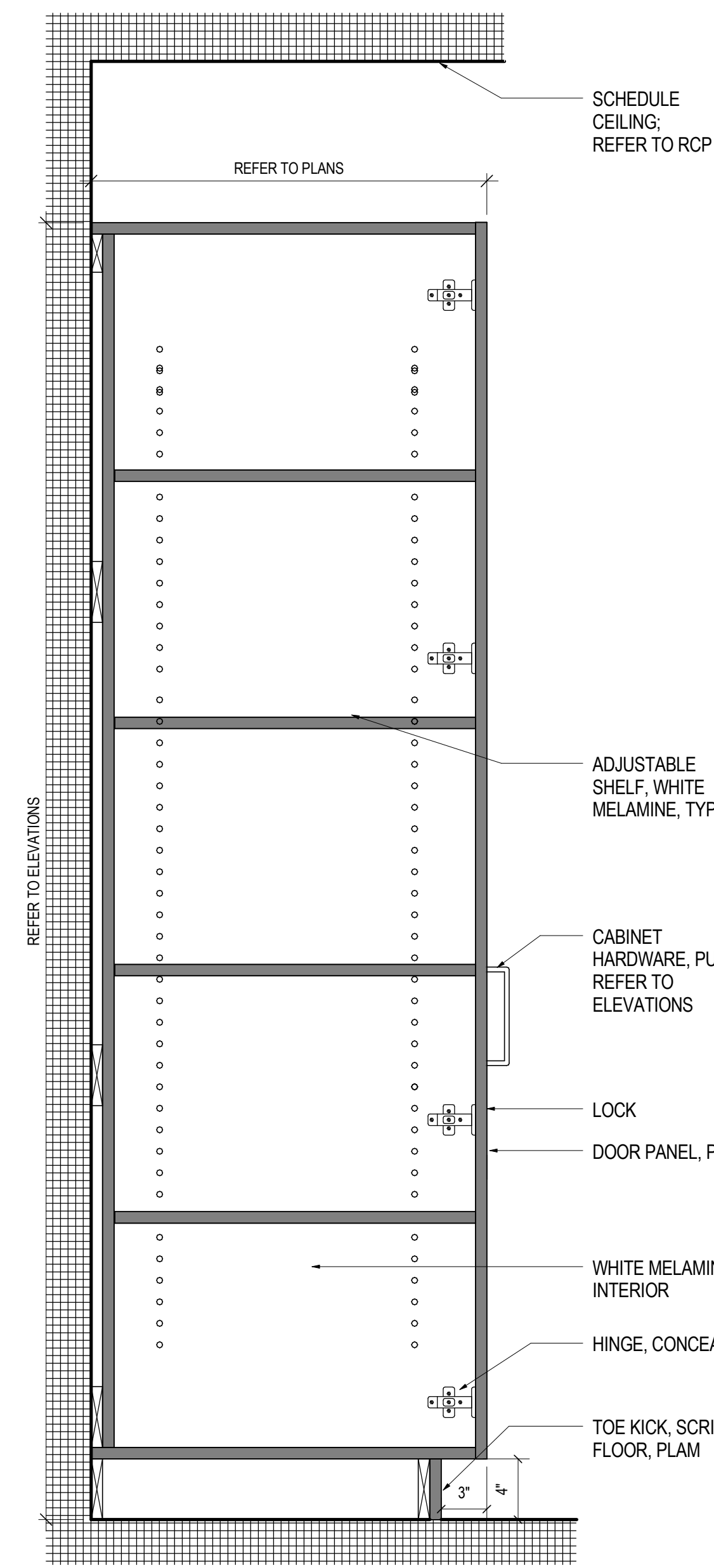

09 FULL HEIGHT CABINET
SCALE: 1 1/2" = 1'-0"

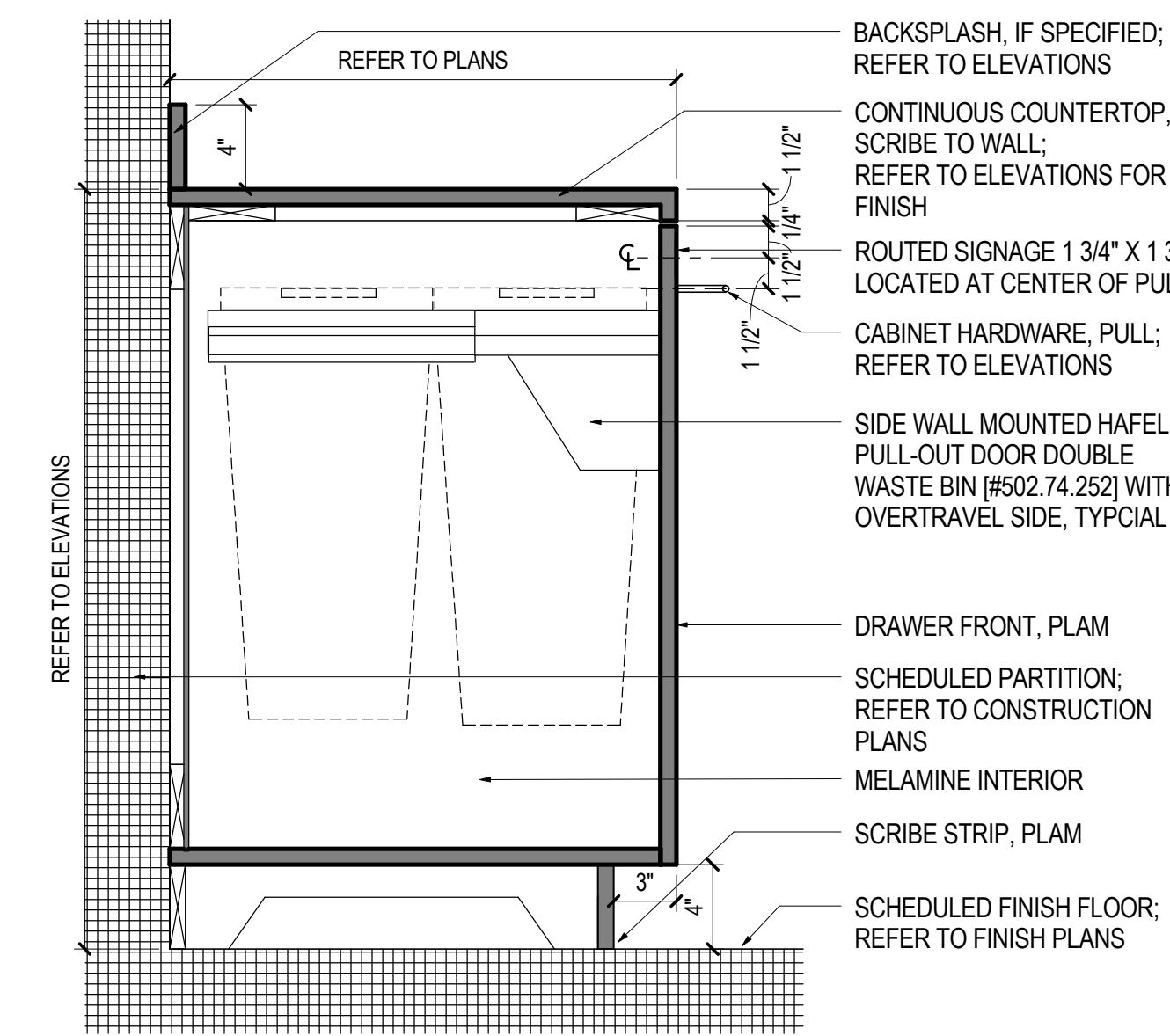

05 BASE CABINET - PULL-OUT TRASH
SCALE: 1 1/2" = 1'-0"

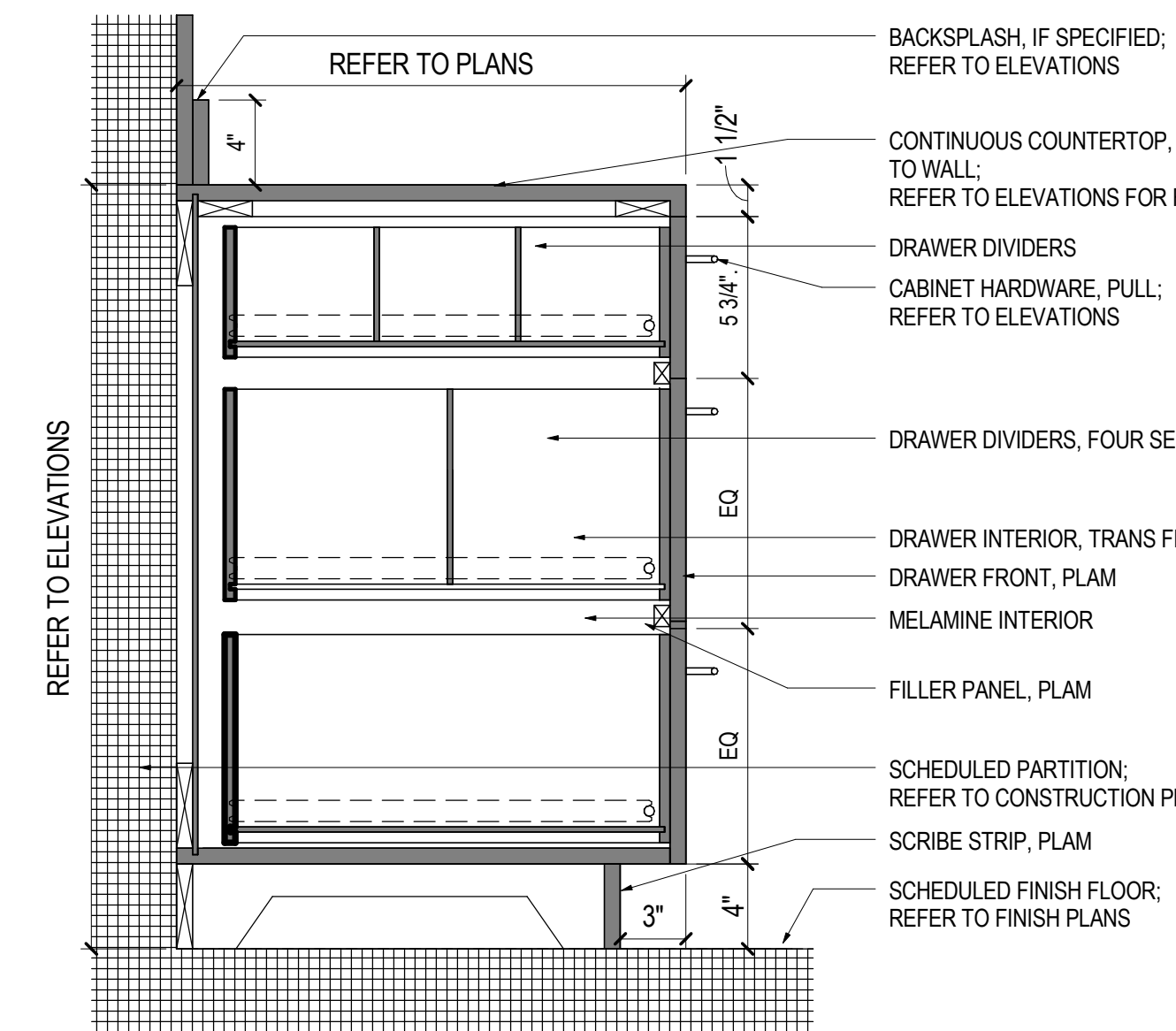

06 BASE CABINET - THREE DRAWERS
SCALE: 1 1/2" = 1'-0"

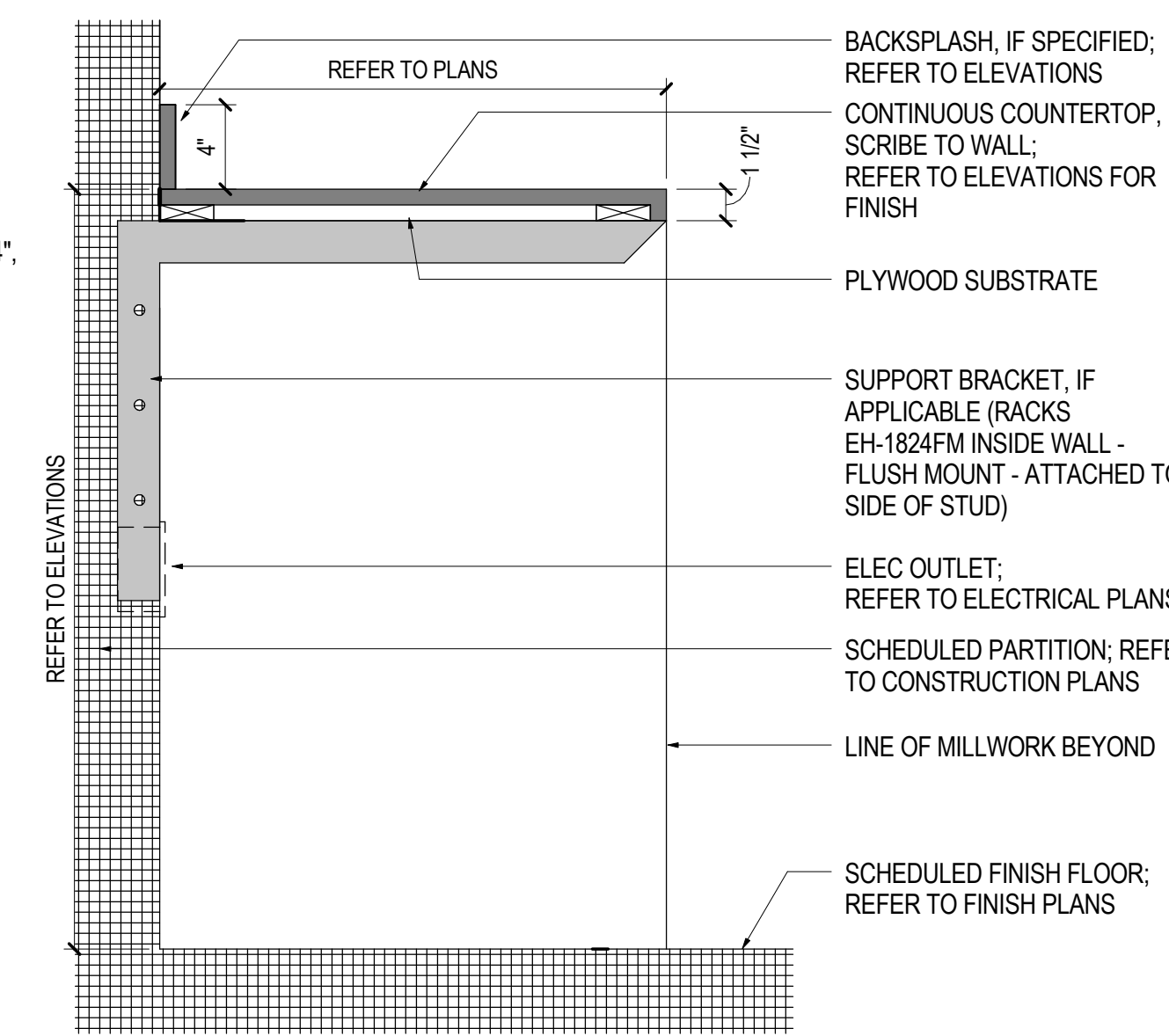

01 COUNTER - OPEN
SCALE: 1 1/2" = 1'-0"

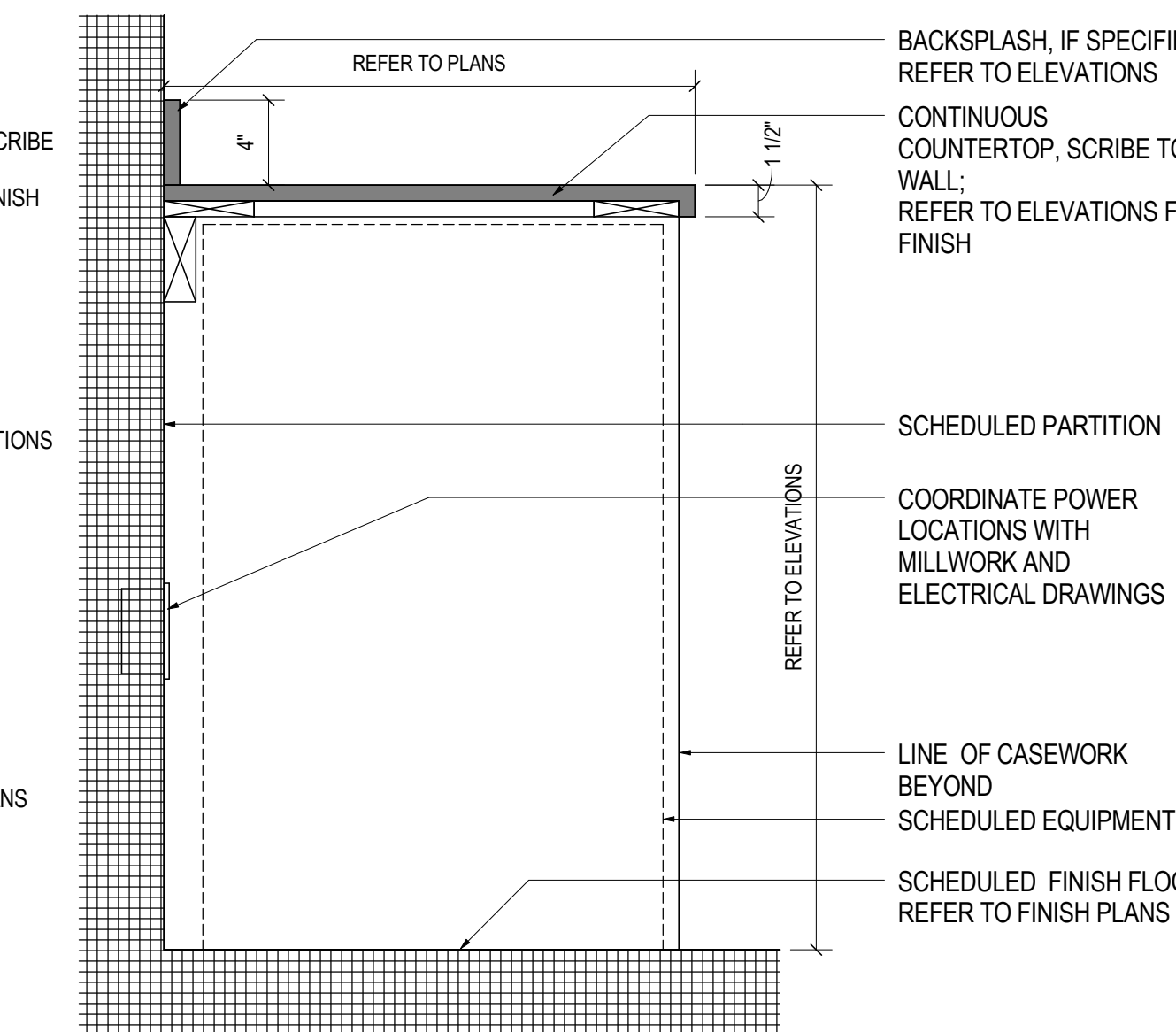

02 COUNTER - EQUIPMENT
SCALE: 1 1/2" = 1'-0"

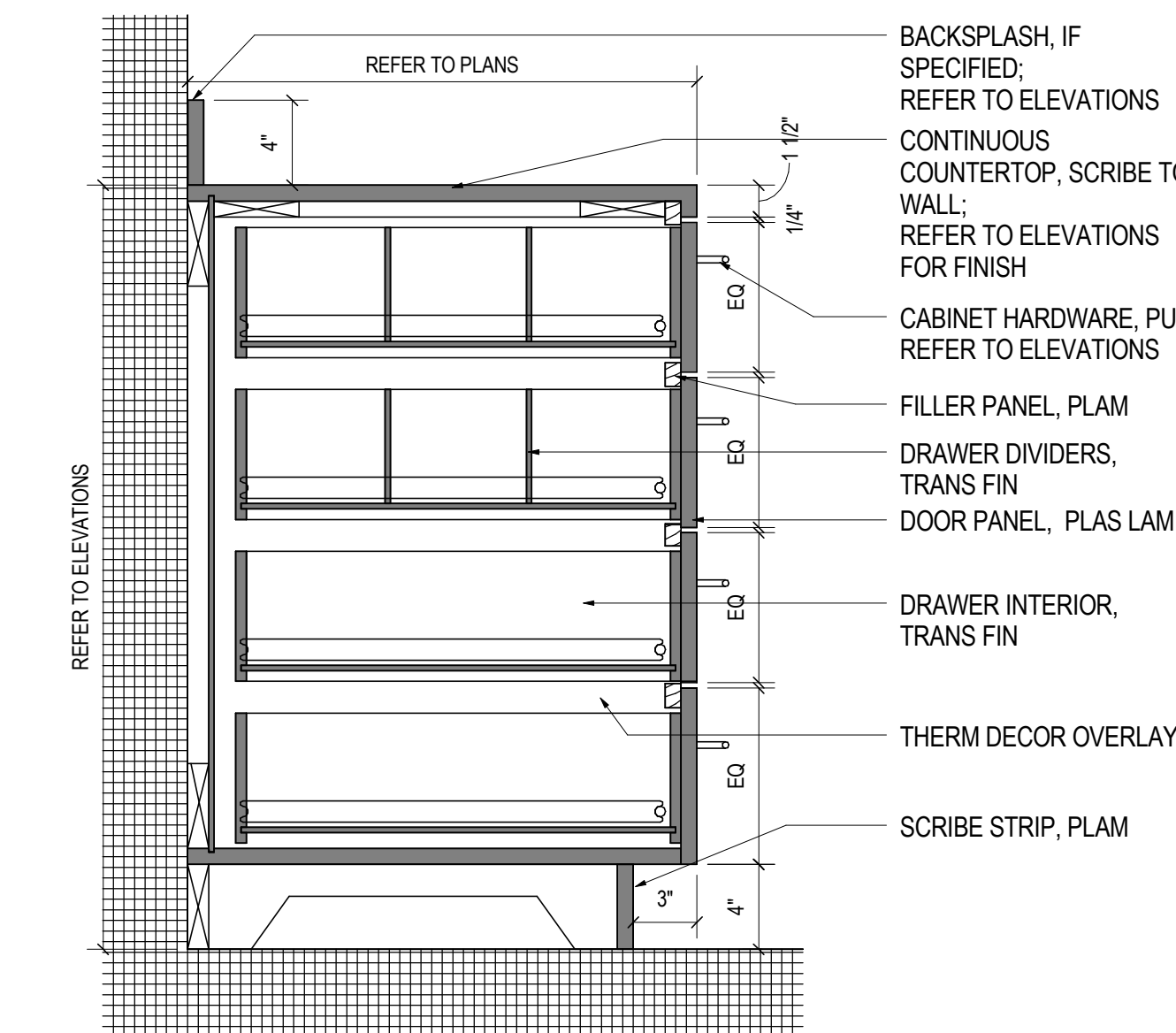

07 BASE CABINET - FOUR DRAWERS
SCALE: 1 1/2" = 1'-0"

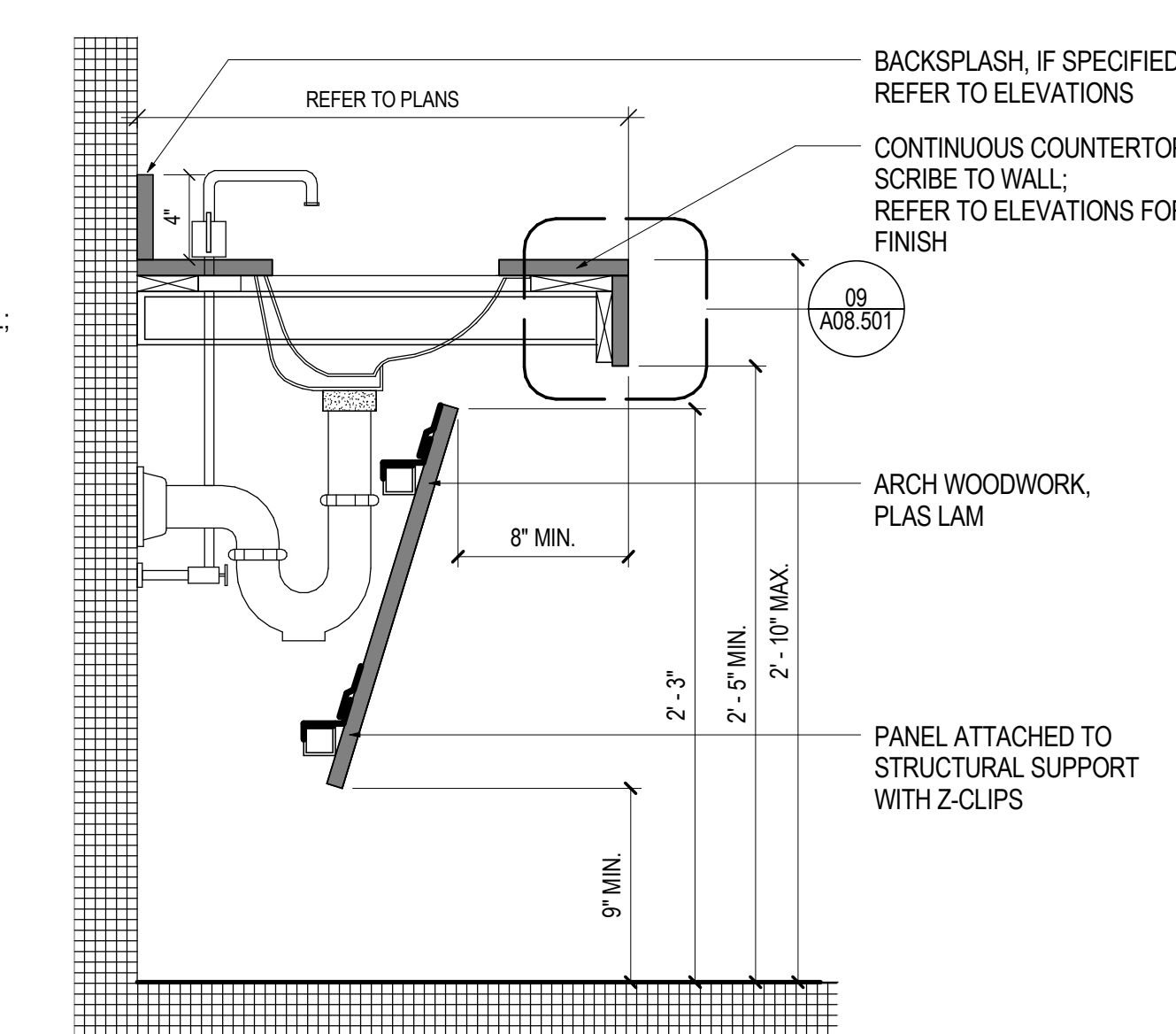

03 COUNTER - ADA LAVATORY
SCALE: 1 1/2" = 1'-0"

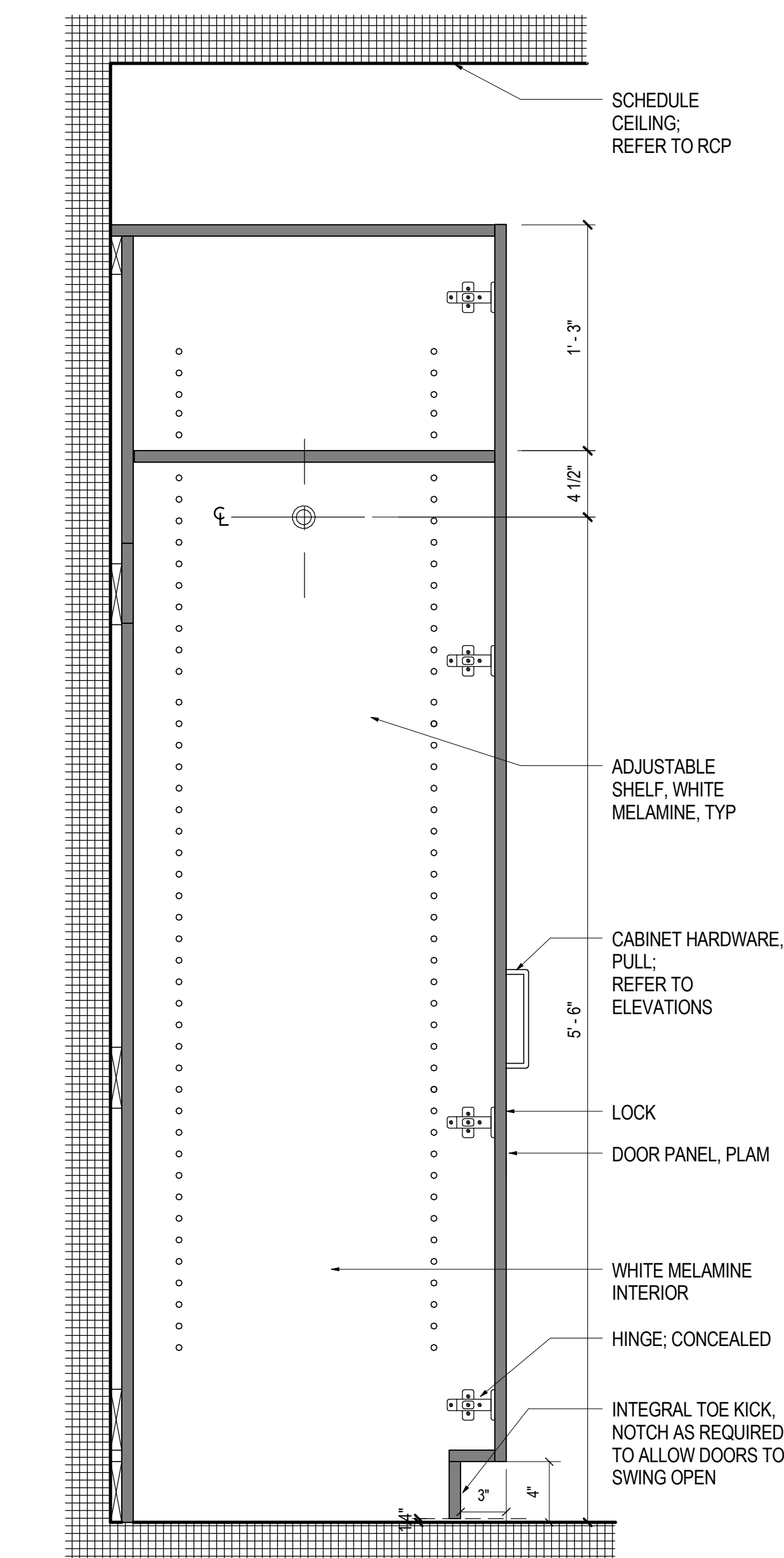

10 FULL HEIGHT LUGGAGE STORAGE
SCALE: 1 1/2" = 1'-0"

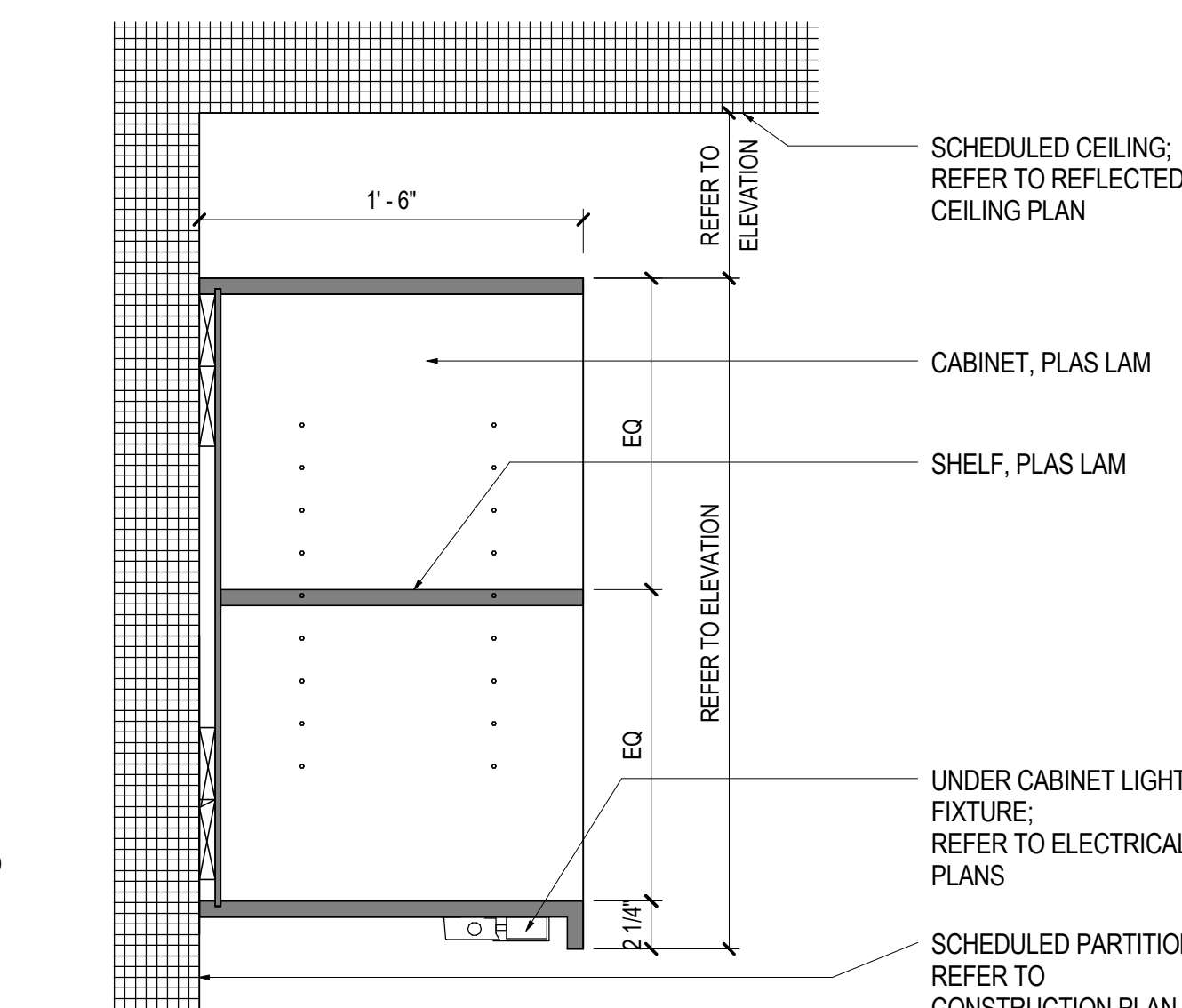

08 UPPER CABINET - OPEN SHELVES
SCALE: 1 1/2" = 1'-0"

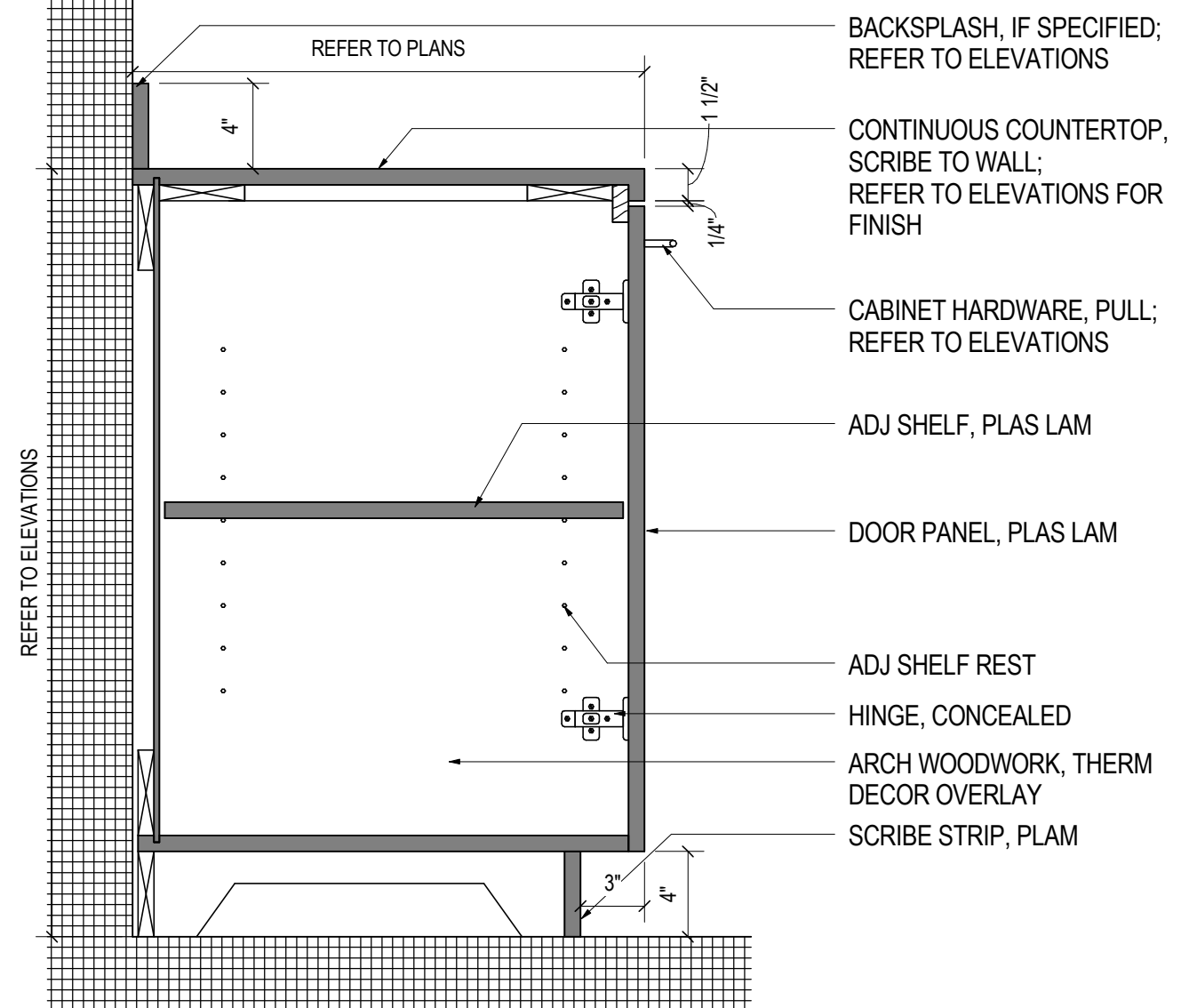

04 BASE CABINET - DOORS
SCALE: 1 1/2" = 1'-0"

