

08 RECEPTION DESK AXON Copy 1
SCALE:

07 RECEPTION DESK AXON
SCALE:

01 RECEPTION DESK - ENLARGED FLOOR PLAN
SCALE: 3/8" = 1'-0"

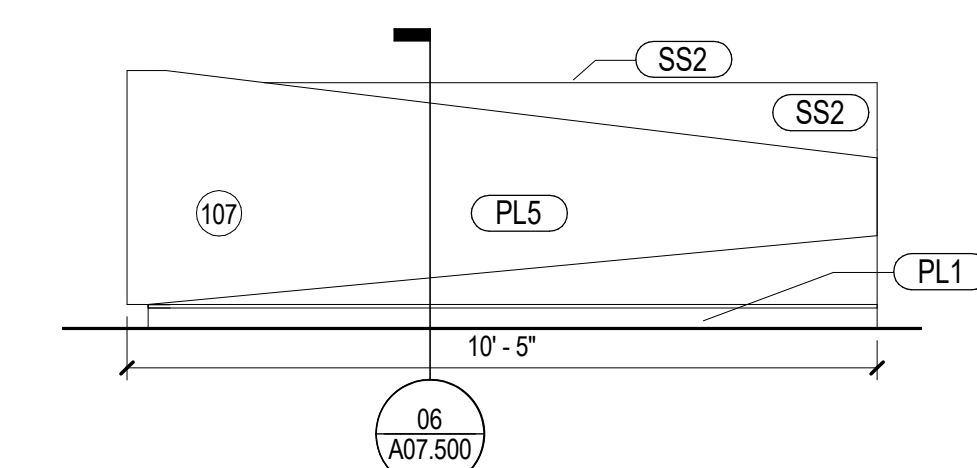
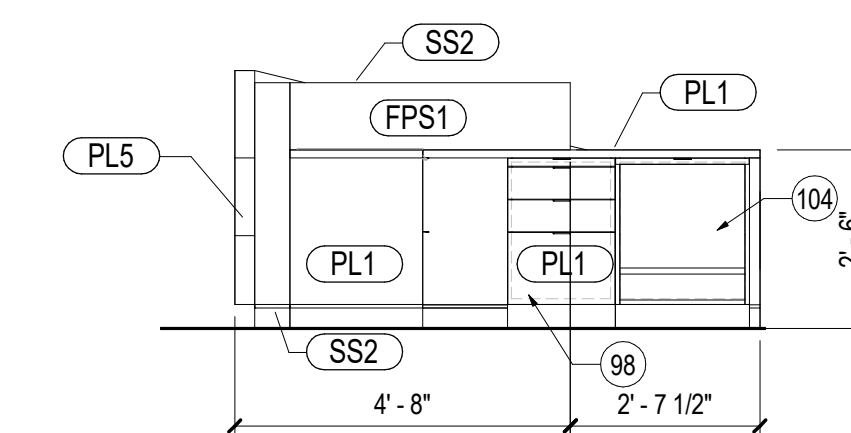

04 RECEPTION DESK - ELEVATION WEST
SCALE: 3/8" = 1'-0"

02 RECEPTION DESK - ELEVATION NORTH
SCALE: 3/8" = 1'-0"

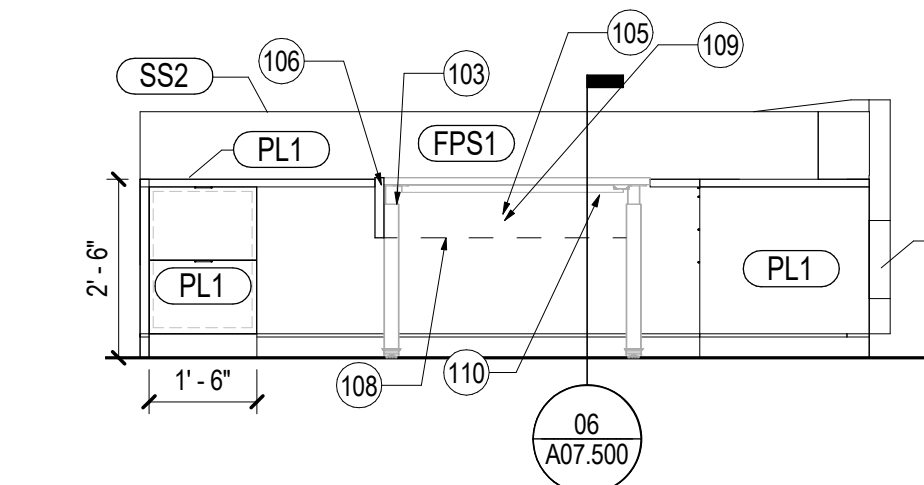
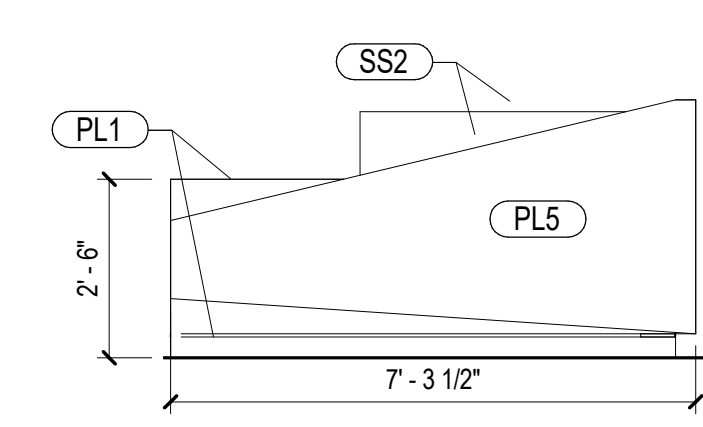
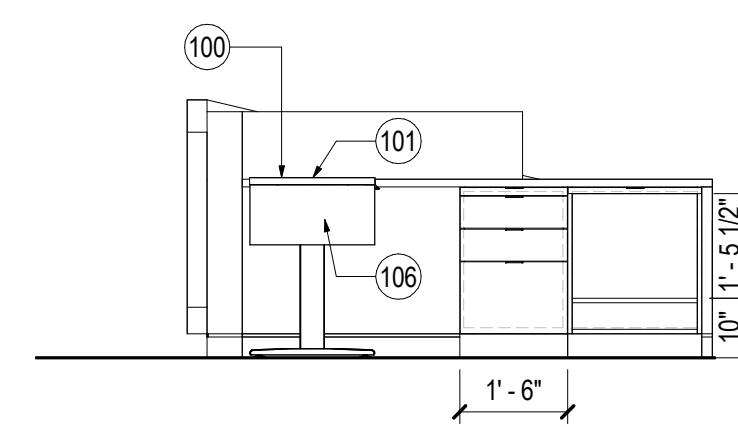

06 Section 13
SCALE: 3/8" = 1'-0"

05 RECEPTION DESK - ELEVATION EAST
SCALE: 3/8" = 1'-0"

03 RECEPTION DESK - ELEVATION SOUTH
SCALE: 3/8" = 1'-0"

Date	Description
12/15/17	ISSUE FOR PERMIT & CONSTRUCTION

12/15/2017 2:35:28 PM I:\gensler\ad\projects\Revit\A07500\A07500-003-UNUM-PORTLAND-HO2-HO3-2016-2516B.rvt

SHEET NOTES

- 98 B/B/F (BOX/BOX/FILE) STORAGE BELOW. PROVIDE FILE DRAWER WITH FILE HANGERS WITH KEY LOCK ON UPPER LEFT HAND CORNER
- 99 PHONE, BY OWNER, WITH GROMMET BELOW
- 100 2 MONITORS (BY FURNITURE VENDOR) WITH DUAL MONITOR ARM
- 101 ADJUSTABLE WORKSURFACE UNIT BASED ON ELECTRIC UPLIFT DESK WITH SHORT FOOT (24") FOR SIZE. WHITE, 110 V, 45DCB. VERIFY CROSSBAR LOCATION IN RELATION TO KEYBOARD TRAY SLIDE (UNIT COMES WITH SPLIT CROSSBAR)
- 102 RADIOCHARGER (BY OWNER)
- 103 GROMMETS TYP AT ALL WORKSURFACES (DOUG MOCKETT, FINISH SATIN STAINLESS STEEL CONFIRM THIS)
- 104 OPEN CABINET WITH ADJ HT PULL-OUT SHELF FOR SMALL PRINTER. VERIFY PRINTER DIMENSIONS AND ADJUSTABLE SHELF AS REQUIRED. PROVIDE POWER/DATA ACCES AT BACK REAR LEFT SIDE.
- 105 WIRE MANAGER J-SHAPED LARGE AT BACK OF UNDERSIDE OF ADJ DESK (WHITE FINISH)
- 106 10" SIDE PANELS SECURED TO TOP OF ADJ WORKSURFACE, PL1
- 107 SS2 QUARTZ WORKSURFACE
- 108 WOODGRAIN PANEL, 10" PL
- 109 POWER AND DATA. COORDINATE EXACT POWER/DATA/USB REQUIREMENTS. PROVIDE OUTLET RATED FOR SMALL SPACE HEATER.
- 110 CPU HOLDER, DOUG MOCKETT, CPU1/CPU8 (SMALL)

GENERAL NOTES

- A. REFER TO SHEETS SERIES A02.100, A02.200 AND I02.100 FOR CONSTRUCTION, REFLECTED CEILING AND FINISH PLAN GENERAL NOTES.
- B. REFER TO FINISH PLAN FOR WALL BASE AS SCHEDULED, TYPICAL.

KEY PLAN

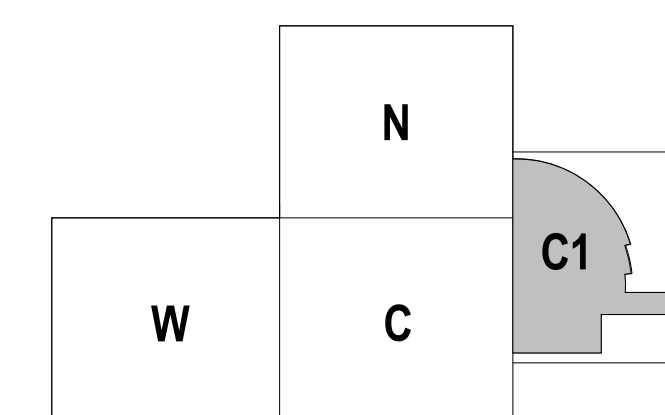

Seal / Signature



Project Name

Unum Workplace Transformation - Phase 2 & 3 (HO2 & HO3)

Project Number

59.6481.003

Description

ENLARGED PLANS AND ELEVATIONS - RECEPTION DESK

Scale

3/8" = 1'-0"

A07.500