

10 LEVEL 01 - ENLARGED PLAN - 1170 FOCUS ROOM
SCALE: 3/8" = 1'-0"

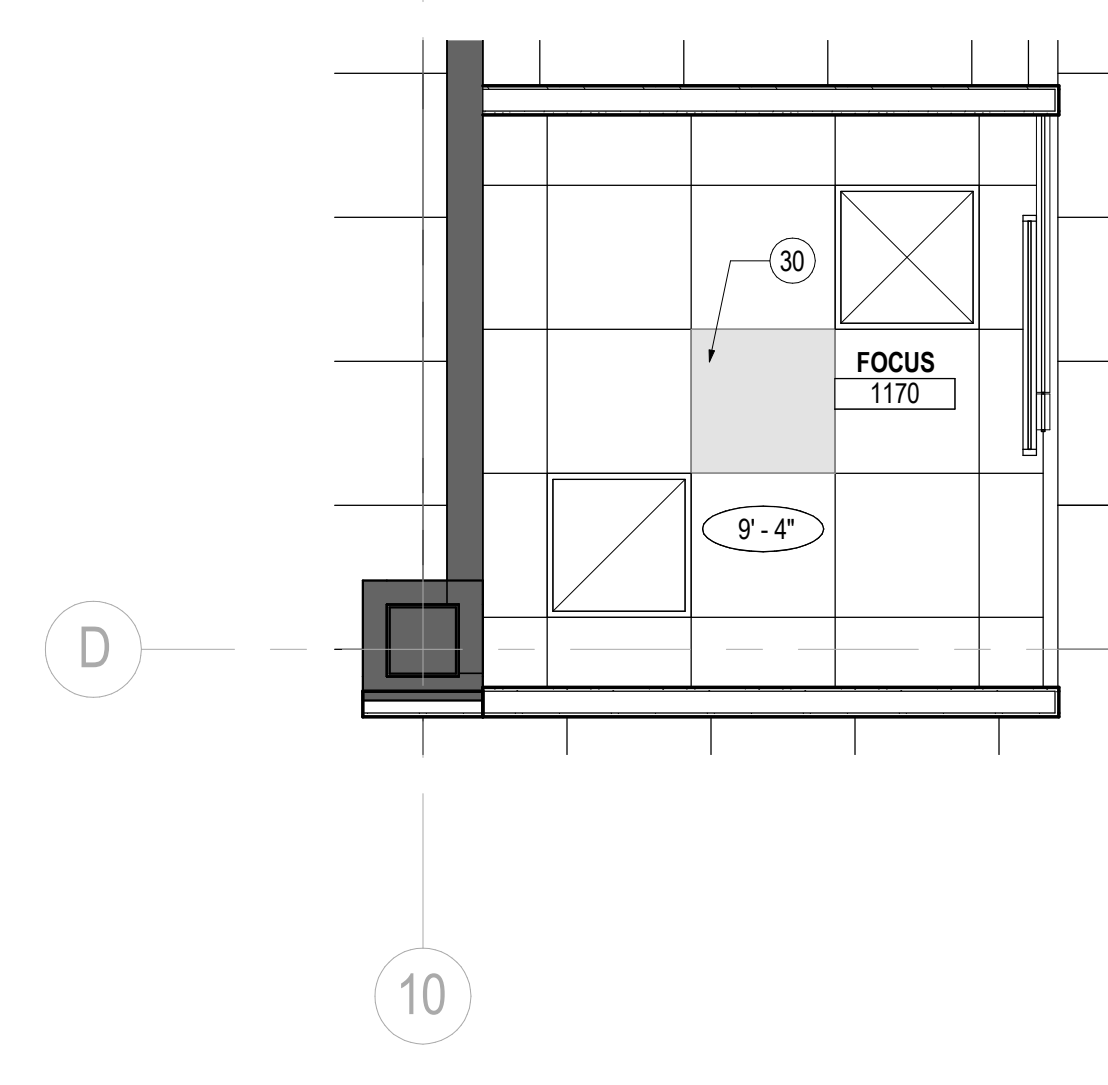

07 LEVEL 01 - ENLARGED RCP - 1170 FOCUS ROOM
SCALE: 3/8" = 1'-0"

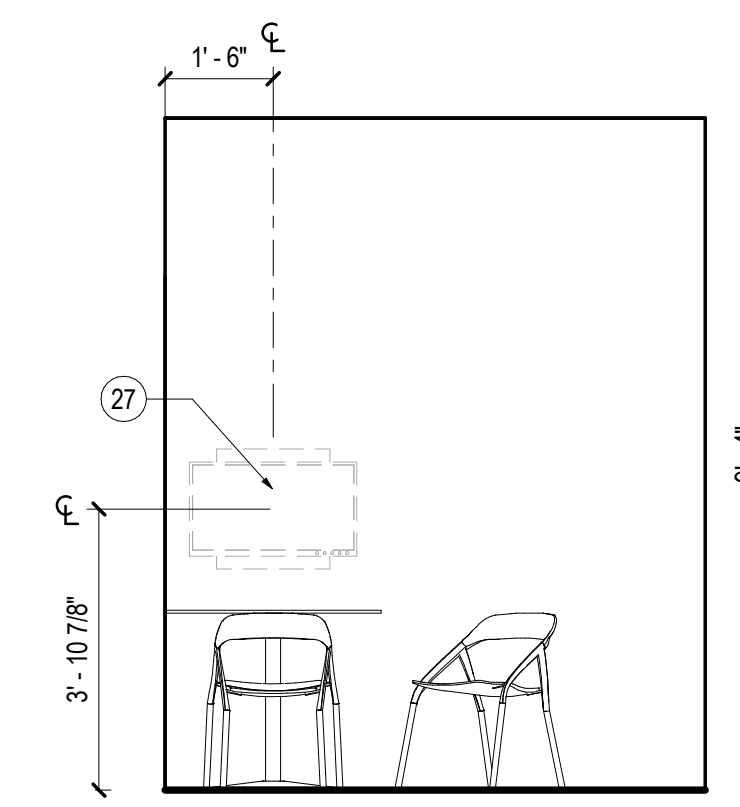

04 1170 - FOCUS ROOM - NORTH ELEVATION
SCALE: 3/8" = 1'-0"

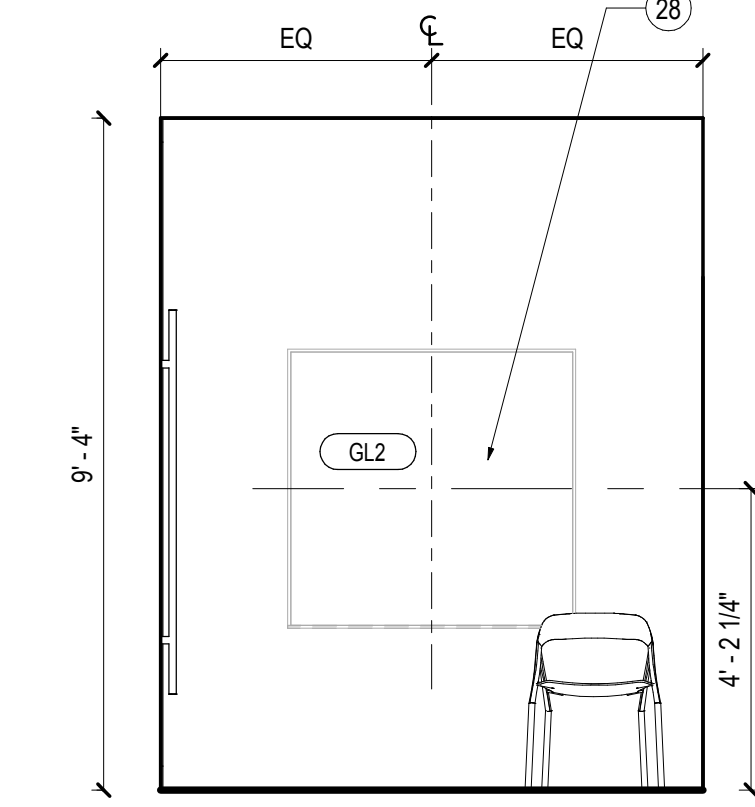

01 1170 - FOCUS ROOM - SOUTH ELEVATION
SCALE: 3/8" = 1'-0"

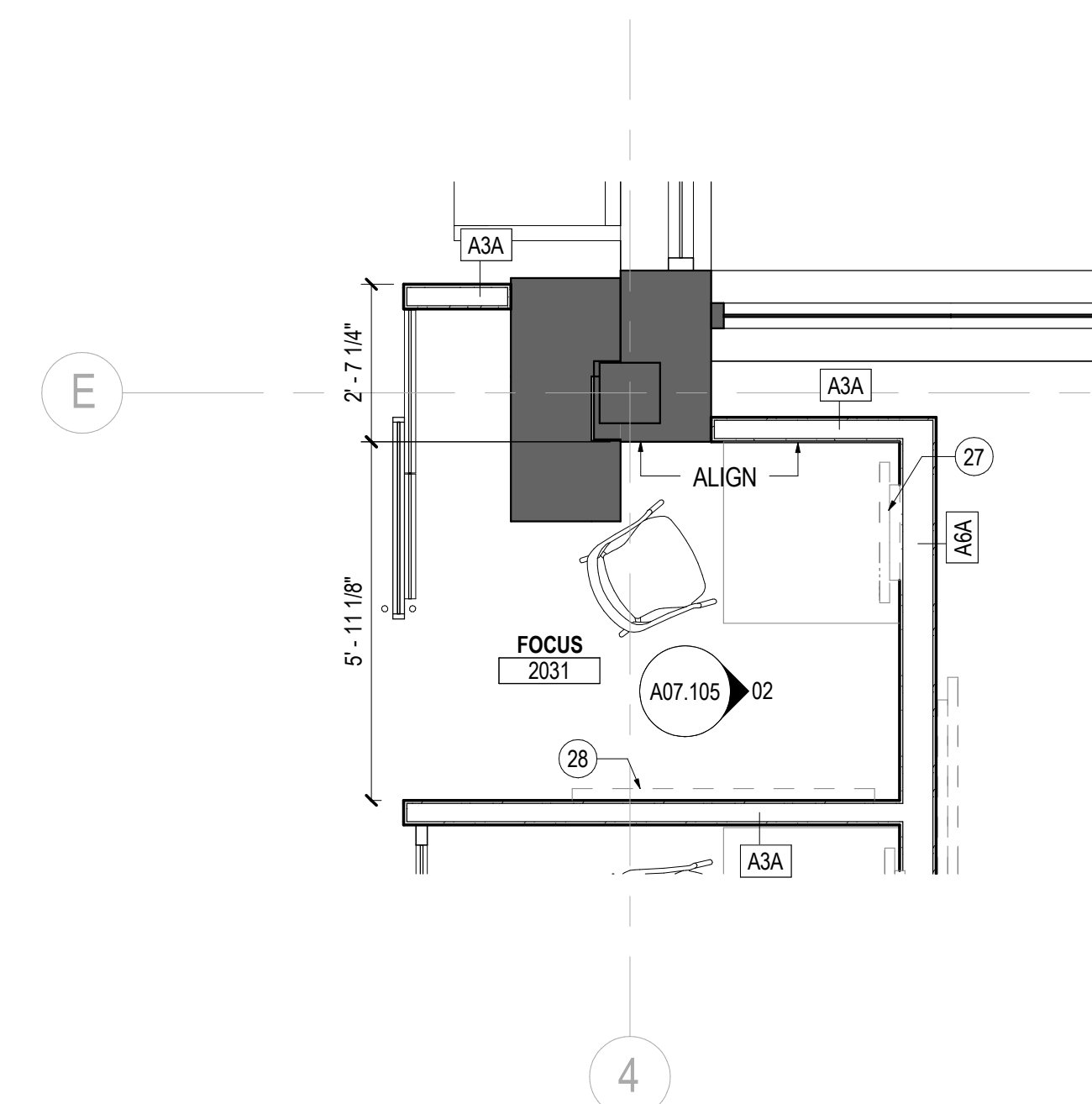

08 LEVEL 02 - ENLARGED PLAN - 2031 FOCUS ROOM
SCALE: 3/8" = 1'-0"

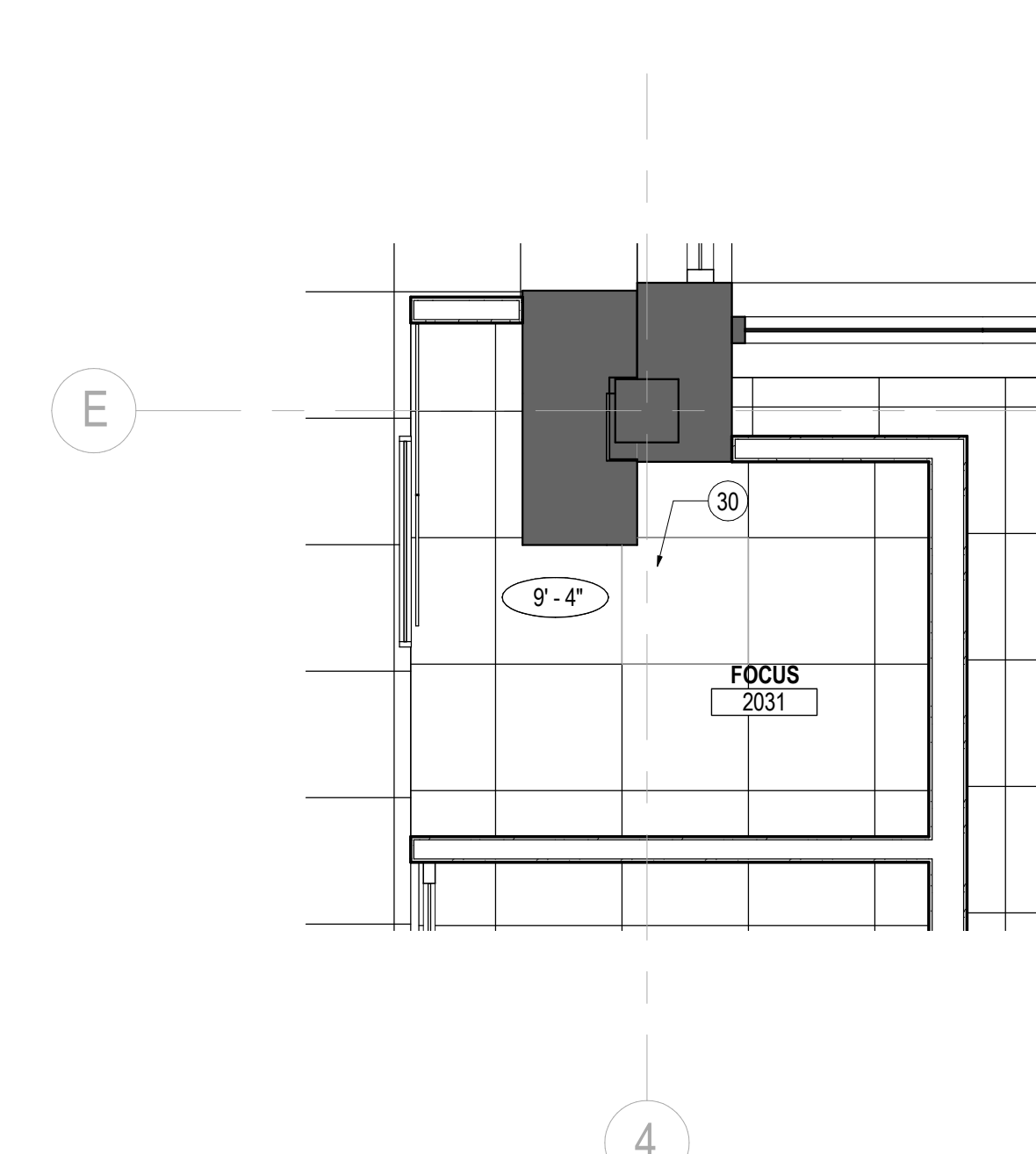

05 LEVEL 02 - ENLARGED RCP - 2031 FOCUS ROOM
SCALE: 3/8" = 1'-0"

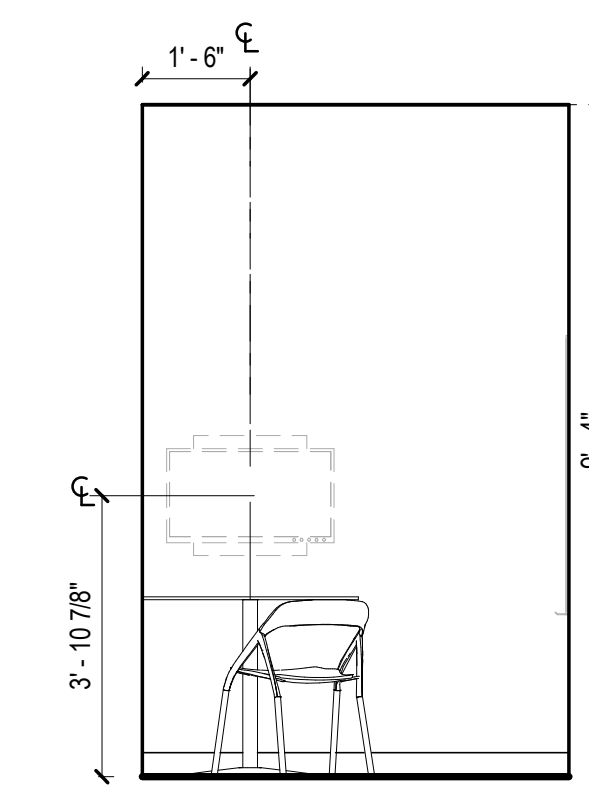

02 2031 - FOCUS ROOM - EAST ELEVATION
SCALE: 3/8" = 1'-0"

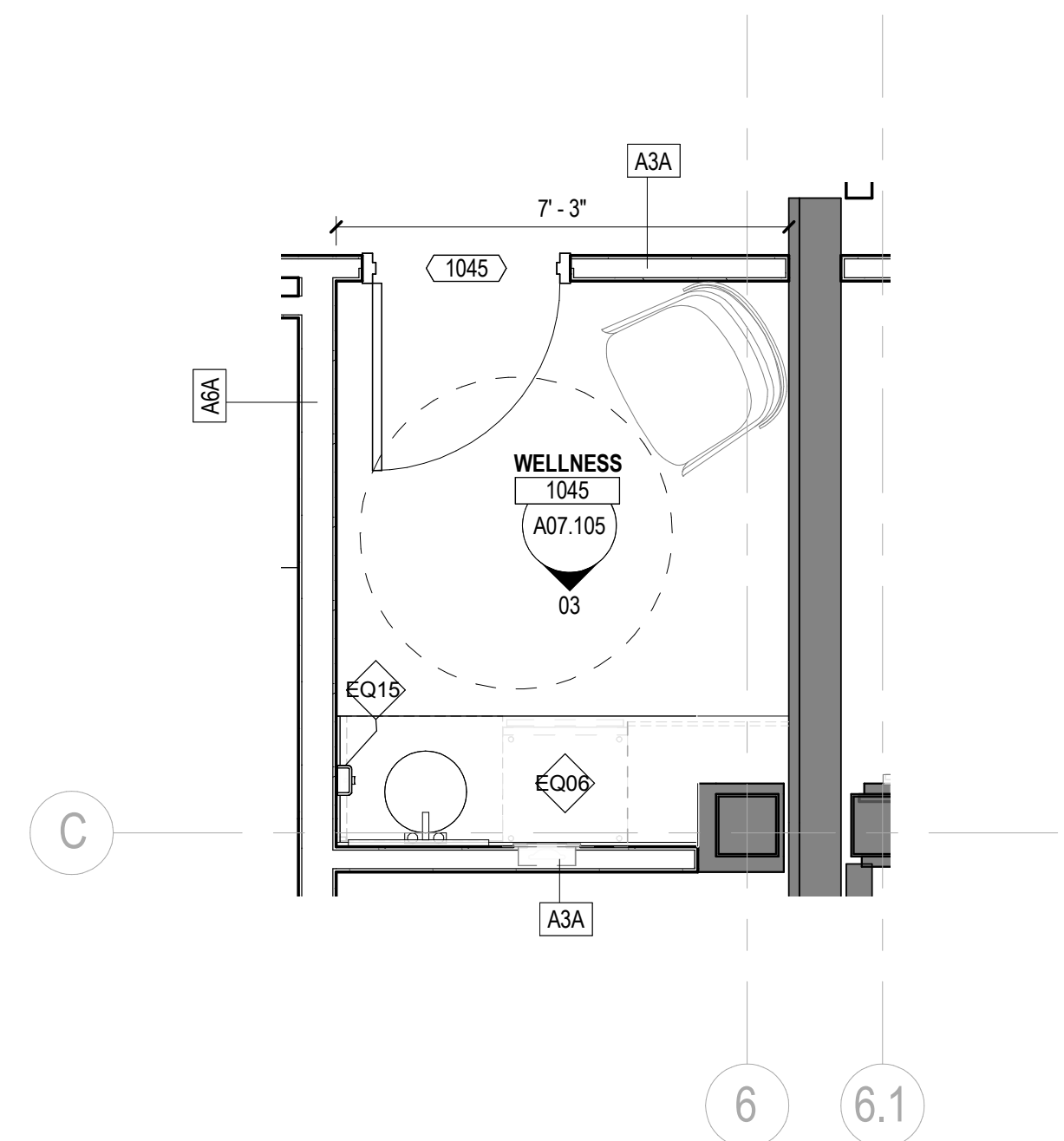

09 LEVEL 01 - ENLARGED PLAN - 1045 WELLNESS ROOM
SCALE: 3/8" = 1'-0"

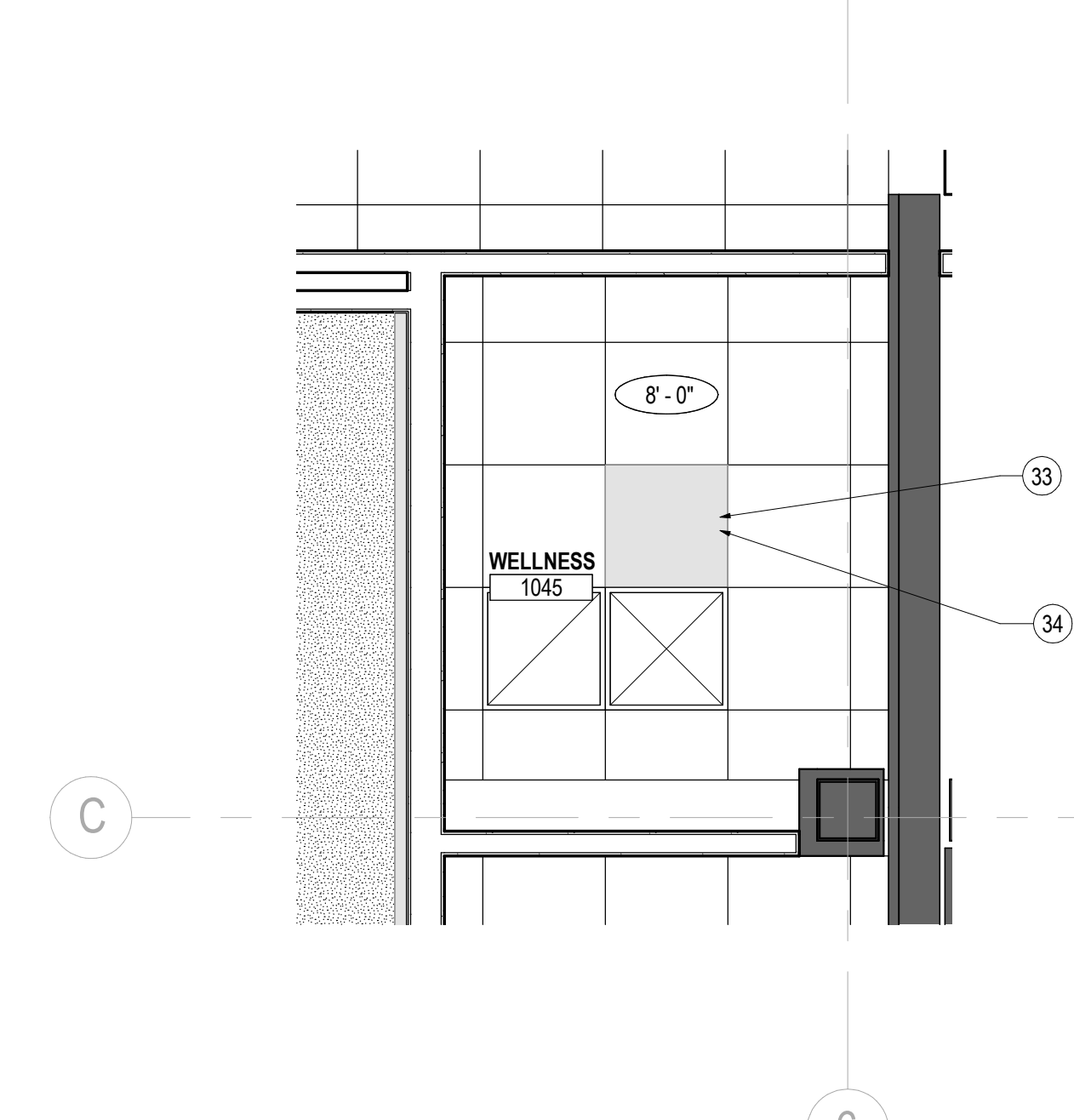

06 LEVEL 01 - ENLARGED RCP - 1045 WELLNESS ROOM
SCALE: 3/8" = 1'-0"

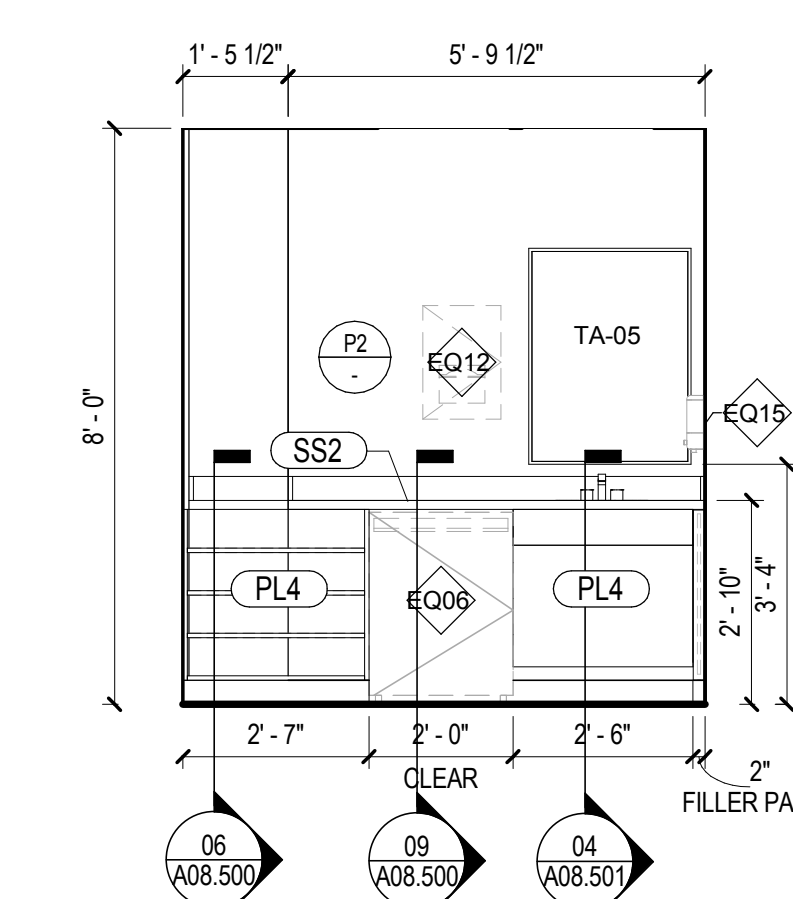

03 1045 - WELLNESS ROOM - SOUTH ELEVATION
SCALE: 3/8" = 1'-0"

SHEET NOTES

- 27 WALL MOUNTED TV, REFER TO ELECTRICAL DRAWINGS
- 28 GC TO PROVIDE WHITE BOARDS, REFER TO FINISH PLAN + FINISH MATERIALS LEGEND FOR SPECIFICATION.
- 30 CENTER LIGHT FIXTURE IN ROOM, REFER TO ELECTRICAL DRAWINGS
- 33 PROVIDE DIMMER, REFER TO ELECTRICAL DRAWINGS
- 34 CENTER LIGHT FIXTURE IN ROOM, REFER TO ELECTRICAL DRAWINGS

GENERAL NOTES

- A. REFER TO SHEETS SERIES A02.100, A02.200 AND I02.100 FOR CONSTRUCTION, REFLECTED CEILING AND FINISH PLAN GENERAL NOTES.
- B. REFER TO FINISH PLAN FOR WALL BASE AS SCHEDULED, TYPICAL.

| EQUIPMENT SCHEDULE | | | |
|--------------------|---------------------------|-------------|--------------|
| TYPE MARK | DESCRIPTION | PROVIDED BY | INSTALLED BY |
| EQ01 | FREEZER | OWNER | OWNER |
| EQ02 | COFFEE MAKER | OWNER | OWNER |
| EQ02 | REFRIGERATOR | OWNER | OWNER |
| EQ03 | ICE MAKER | OWNER | GC |
| EQ04 | DISHWASHER | OWNER | GC |
| EQ05 | MICROWAVE | OWNER | OWNER |
| EQ06 | UNDERCOUNTER REFRIGERATOR | OWNER | GC |
| EQ07 | VENDING SNACK MACHINE | OWNER | OWNER |

| EQUIPMENT SCHEDULE | | | |
|--------------------|--|-------------|--------------|
| TYPE MARK | DESCRIPTION | PROVIDED BY | INSTALLED BY |
| EQ10 | COPIER - FLOOR STANDING | OWNER | OWNER |
| EQ11 | TRASH/RECYCLING BIN | OWNER | OWNER |
| EQ12 | RECESSED PAPER TOWEL DISPENSER | OWNER | OWNER |
| EQ13 | COUNTER MOUNTED AUTOMATIC SOAP DISPENSER, TOP LOADING REFILL BLACK MATTE FINISH. | GC | GC |
| EQ14 | LOCKERS | OWNER | GC |
| EQ15 | DISPENSER, SOAP, DISPOSABLE | OWNER | GC |
| EQ16 | | | |

KEY PLAN

| Date | Description |
|----------|---------------------------------|
| 08/18/17 | ISSUE FOR PERMIT & CONSTRUCTION |

Seal / Signature

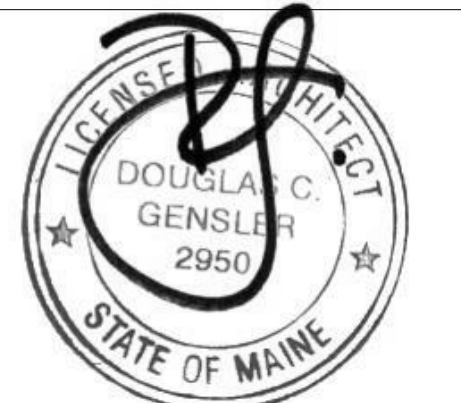

Project Name

Unum Workplace Transformation- Phase 1 (H02)

Project Number

59.6481.003

Description

ENLARGED PLANS AND INTERIOR ELEVATIONS - MEETING ROOMS

Scale

3/8" = 1'-0"

A07.105