

GENERAL CEILING NOTES:

1. CEILING PLANS DO NOT SHOW EVERY FIXTURE OR COMPONENT. REFER TO ELECTRICAL, PLUMBING, MECHANICAL AND STRUCTURAL DRAWINGS FOR EXTENT OF ALL CEILING PENETRATIONS AND INSTALLATIONS AND COORDINATE PRIOR TO INSTALLATION.
2. SEE MECH. DRAWINGS FOR RETURNS AND DIFFUSER LOCATIONS AND SIZES. SHOWN HERE FOR REFERENCE ONLY.
3. SEE ELEC. DRAWINGS FOR LIGHT TYPES AND ADDITIONAL INFORMATION.
4. ALLOW FOR 15% OF INTENDED CEILING TILE REUSE / REINSTALLATION TO BE REPLACED.

CEILING TYPES:

C1	2'X4' ACOUSTICAL CEILING TILE
C2	2'X2' ACOUSTICAL CEILING TILE
GWB	GWB SOFFIT OR CEILING
EXP	EXPOSED STRUCTURE

GRAPHIC LEGEND

	EXISTING WALLS TO REMAIN
	WALLS TO BE DEMOLISHED
	NEW WALLS
	EXISTING ADA/POWER ASSIST
	EXISTING FIRE EXTINGUISHER
	EXISTING FIRE EXTINGUISHER WITH CABINET
	FIRE EXTINGUISHER
	FIRE EXTINGUISHER WITH CABINET
	ADA/POWER ASSIST
	INSTALL RATED FLOOR BOX
	FLOOR DRAIN
	AREA NOT IN SCOPE OF WORK
	AREA OF FLOOR DEMOLITION
	AREA OF FIREPROOFING
	AREA OF SPRINKLER WORK ONLY
	KEYNOTE

EXISTING CEILING TYPES:

XC1	EXISTING 2'X2' CEILING TILE
XC2	EXISTING 2'X4' CEILING TILE
XGWB	EXISTING GWB SOFFIT OR CEILING
EXP	EXPOSED STRUCTURE

CEILING FIXTURES LEGEND:

	EXISTING LIGHTING FIXTURES - INCLUDES DIRECT / INDIRECT FLOURESCENT NITE AND EMERGENCY LIGHTS - BOTH 2'X2 & 2'X4. FLOURESCENT LIGHT TROFFER & FLOURESCENT LIGHT - LENSED
	PLENUM RETURNS (SIZE VARY)
	LINEAR PENDANTS
	RECESSED CAN
	LINEAR FLOURESCENT STRIP LIGHT
	DIFFUSER
	SPEAKER
	MIRROR (SALVAGE)
	CEILING MOUNTED STROBEHORN
(R)	RELOCATED LIGHT FIXTURE

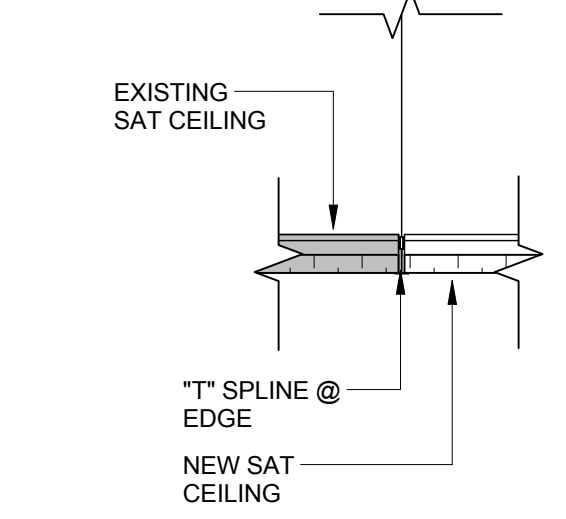

B2 CEILING DETAIL - SAT TO SAT ALIGNED (TYP)
 1/2" = 1'-0"

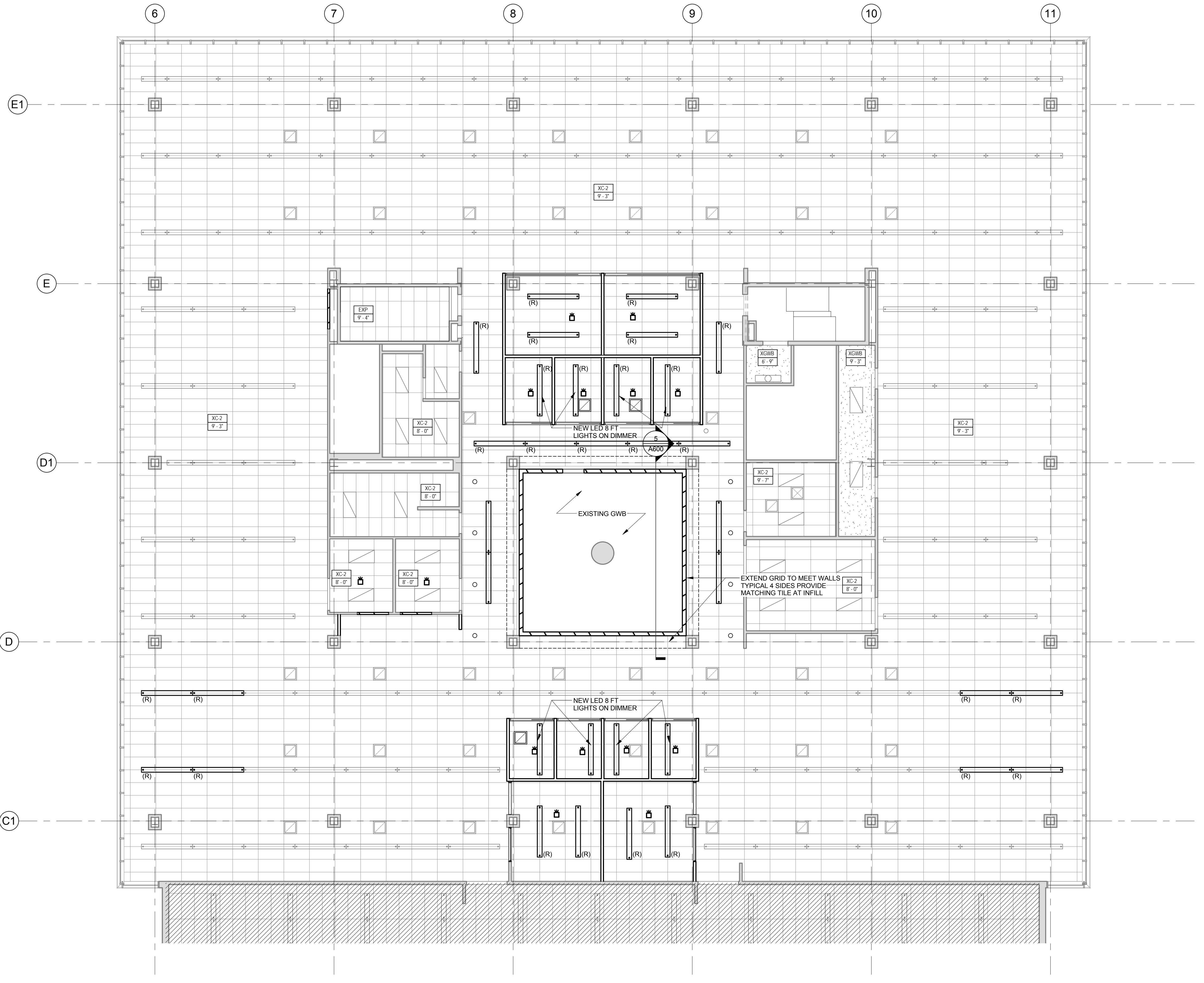
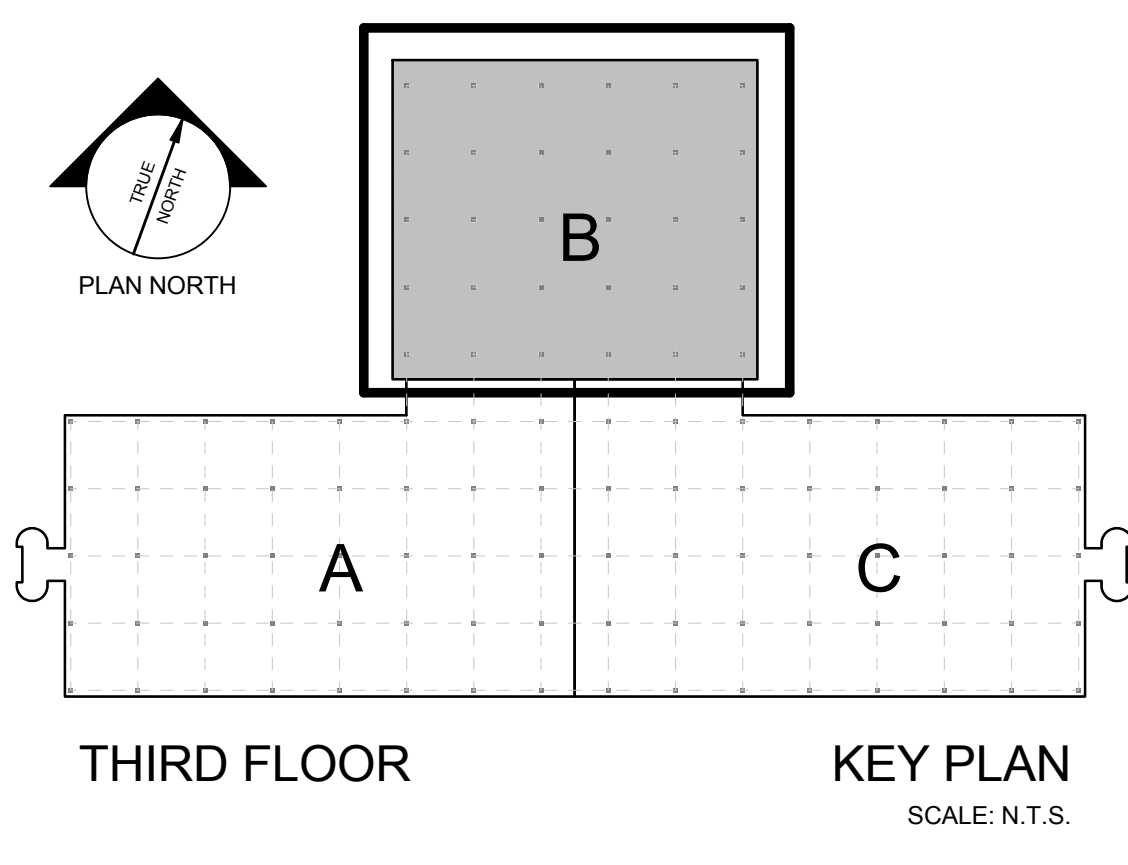
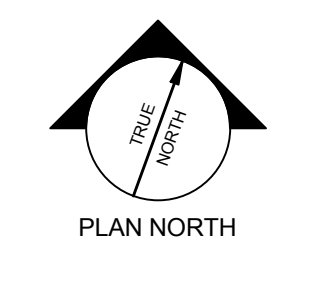

1 THIRD FL. - REFLECTED CEILING PLAN
 1/8" = 1'-0"

